

Strategos, Inc.  
3916 Wyandotte  
Kansas City MO 64111 USA  
816-931-1414

# Ergonomics in Lean Manufacturing

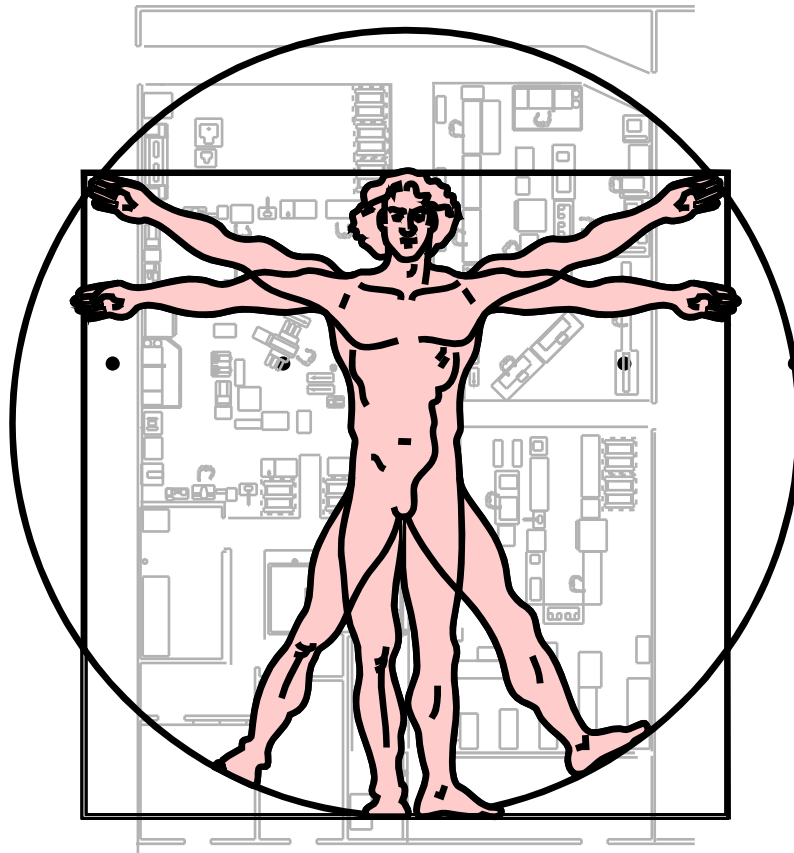

By  
Quarterman Lee, P.E.  
& William Nelson  
Strategos, Inc.

*Strategos*

CONSULTANTS • ENGINEERS • STRATEGISTS

[www.strategosinc.com](http://www.strategosinc.com)

# Ergonomics in Lean Manufacturing

## Ergonomics & Lean Manufacturing

Ergonomics studies work as it relates to the human body and its limits. Ergonomics can help manufacturing and industrial engineers maximum work output without physical harm to workers.

Physiology, biomechanics, anthropometrics, worker selection and allocation are the areas of ergonomics most useful to manufacturing and industrial engineers. The most prevalent ergonomic related injuries are musculoskeletal; either from repetition, overload, awkward positions or some combination thereof.

Ergonomics is most important at the level of workcell and workstation design. By their very nature, well-designed Lean Manufacturing cells relieve many of the risk factors associated with traditional workstations and functional layouts. For example, workcells often rotate workers through an entire process on each cycle. This reduces repetition and static postures.

## Musculoskeletal Disorders & Lean Manufacturing

Work-related Musculoskeletal Disorders (WMSDs) are among the most common disorders to be considered in designing workcells and workstations. Here are the most common WMSDs, symptoms and risk factors. See also our Biomechanics page.

### Other Terms for WMSD

- Repetitive motion injuries
- Repetitive strain injuries
- Cumulative trauma disorders
- Overuse syndrome
- Soft tissue disorders

Disorders	Occupational Risk Factors	Symptoms
<b>Tendonitis/ tenosynovitis</b>	Repetitive wrist motions Repetitive shoulder motions Sustained hyper extension of arms Prolonged load on shoulders	Pain, weakness, swelling, burning sensation or dull ache over affected area
<b>Epicondylitis (elbow tendonitis)</b>	Repeated or forceful rotation of the forearm and bending of the wrist at the same time	Same symptoms as tendonitis
<b>Carpal tunnel syndrome</b>	Repetitive wrist motions	Pain, numbness, tingling, burning sensations, wasting of muscles at base of thumb, dry palm
<b>DeQuervain's disease</b>	Repetitive hand twisting and forceful gripping	Pain at the base of thumb
<b>Thoracic outlet syndrome</b>	Prolonged shoulder flexion Extending arms above shoulder height Carrying loads on the shoulder	Pain, numbness, swelling of the hands
<b>Tension neck syndrome</b>	Prolonged restricted posture	Pain

## Physiology

In some respects, the body is analogous to an automobile. In the human machine, muscles are both cylinders and pistons, and bones and joints are the gears. The muscles oxidize nutrients (fuel) and give up energy, while generating metabolic byproducts (waste). Physiology studies this process.

Two categories of physiological demands usually are relevant during work: static and dynamic. Static work occurs when the body is in a stationary position for an extended period. Dynamic work involves considerable movement.

The musculoskeletal system is unsuited for prolonged static work because the body cannot supply fresh nutrients to the stressed tissues. In addition, waste products remain at the stressed site. Muscles and tendons can inflame. Even at static loads as low as 30 percent of maximum strength, fatigue develops rapidly.

In dynamic work nutrients and waste products move to and from the muscles. Consequently, the muscles can work for extended periods if the maximum load on the body is significantly less than the maximum static capability.

Endurance usually limits dynamic work when loads are not extreme. Toyota uses this effect by designing workcells that require considerable walking and movement. This reduces static work with a slight increase in dynamic work. There are many other advantages such as allowing work balance through circulation.

Usually, tasks should not require operators to exert more than 30 percent of their maximum muscle force in a prolonged or repetitive way. All muscular exertions beyond 50 percent of the maximum level should be avoided.

## Allocation of Functions

Allocation divides work between people and machines. It determines, to a large extent, the quality of work experience. A well-thought-out allocation optimizes the interaction of people and machine elements. Allocation also relates to Socio-Technical Systems (STS).

### **What should machines do; what should people do?**

These are important decisions in the design of any workstation, manufacturing system or process. Such decisions affect product quality, flexibility, overhead cost, worker health and the economic viability of the process.

#### *An Over-Automation Example*

In the early days of the Mercury space program, NASA engineers attempted to automate almost every aspect of space flight. The original Mercury 7 astronauts vehemently objected to their proposed role as mere passengers. They called it "Spam In A Can." As a result, Mercury and subsequent manned spacecraft designs assigned significant roles and tasks to the astronauts. The unique value that humans bring to certain tasks was demonstrated dramatically with the Apollo 13 mission.

This is an example of the strong tendency in some organizations to "over-automate" and assign most tasks to machines. However, insufficient automation is equally ineffective. Much depends on the state of the technology and the relative economics of automation and labor.

# The Person-Machine System

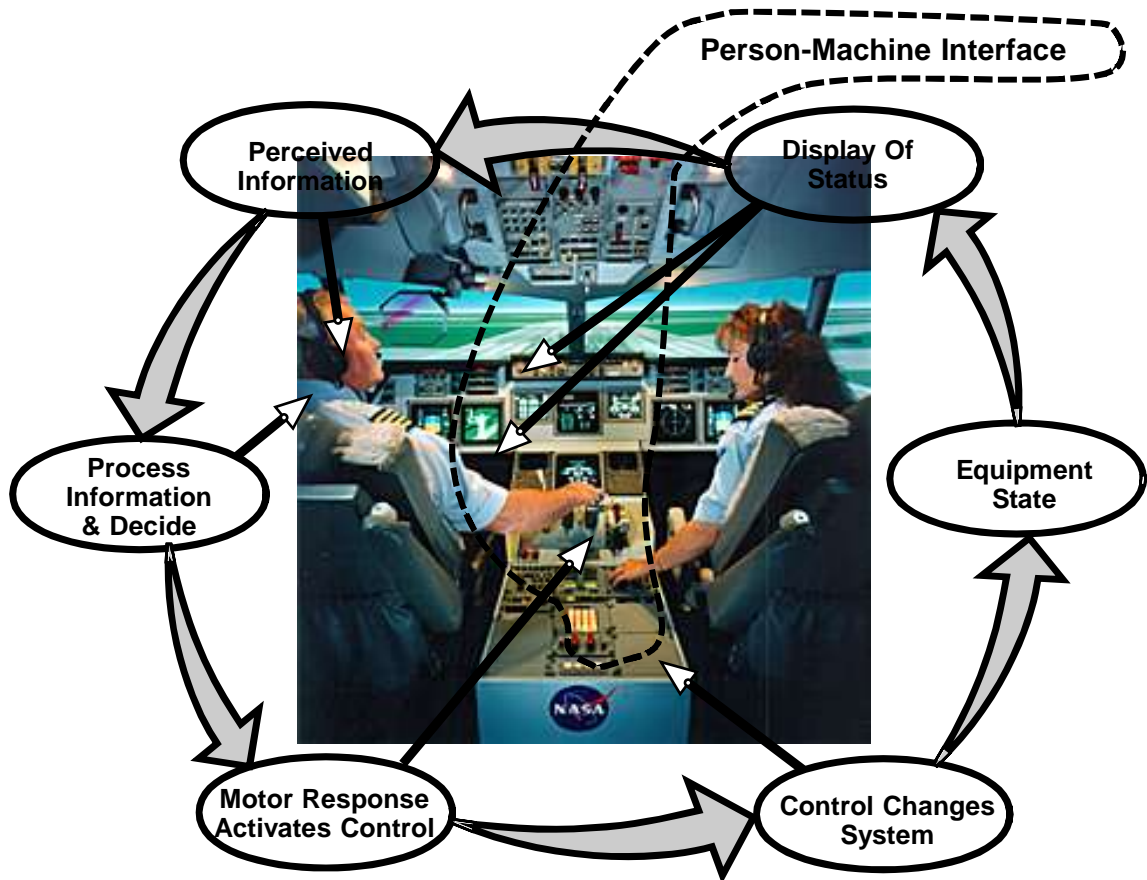

The list below shows some of the relevant factors for making such decisions.

What People Are Good At	What Machines/Computers Are Good At
<ul style="list-style-type: none"> <li>• Nebulous Information</li> <li>• Subtle Decisions</li> <li>• Vague Process Definitions</li> <li>• Interactions With Other People</li> <li>• High Variety</li> <li>• Short Runs</li> <li>• Varied Cycle Times</li> <li>• Quick Changeover</li> <li>• Varied Inputs</li> <li>• Multiple Work Locations</li> </ul>	<ul style="list-style-type: none"> <li>• Simple, Quantitative &amp; Accurate Information</li> <li>• Simple, Straight-Forward Decisions</li> <li>• Sharply Defined Processes</li> <li>• No Customer Interfaces</li> <li>• Repetition</li> <li>• Short Cycle times</li> <li>• Long Runs</li> <li>• High Volume</li> <li>• High Precision</li> <li>• Heavy Loads/Large Forces</li> </ul>

## Biomechanics

Biomechanics studies the mechanical forces in human movement. Its principles can help to minimize damage to muscles, joints, and tissues. This damage may come from a one-time force, such as lifting an object that is too heavy or moving an object from an awkward position. Damage also can come from an accumulation of small, repetitive forces--Cumulative Trauma Disease (CTD).

### Practical Application of Biomechanic Principles

Biomechanics studies the mechanical forces in human movement. Its principles can help to minimize damage to muscles, joints, and tissues.

One-time forces that are simply too great for the joint or muscle can create damage. However, workers are usually aware of direct, one-time overloads. The effects are felt immediately, perhaps before damage has occurred. Several factors can multiply forces and aggravate damage. The worker is often unaware of these aggravating factors.

### Aggravating Factors

#### *Extreme Joint Position*

Joints placed in extreme positions or angles amplify many biomechanical forces. Thus a load that seems very manageable to the worker may actually cause serious damage. The worker may not be aware of this damage until too late.

#### *Repetition*

Highly repetitive movements without time for rest and healing can create damage even when the forces are quite small. The worker is often unaware of the damage for days or weeks.

### Risky Actions & Position Examples

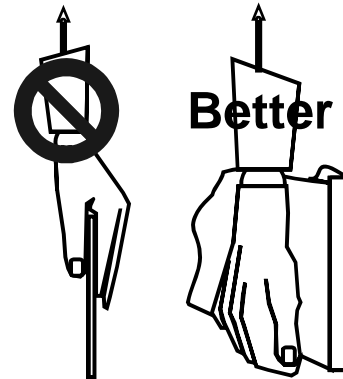
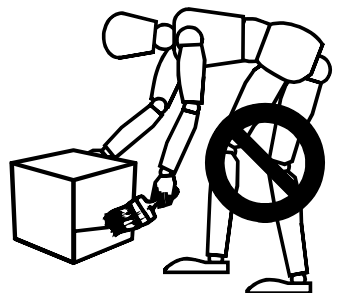
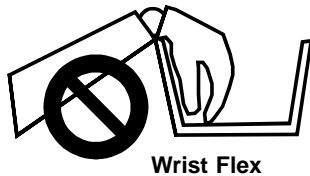
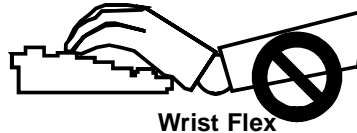
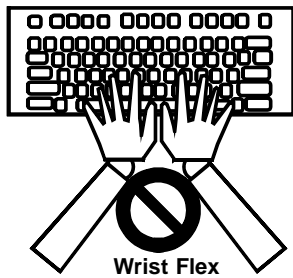

Hook grip is better than pinch grip.

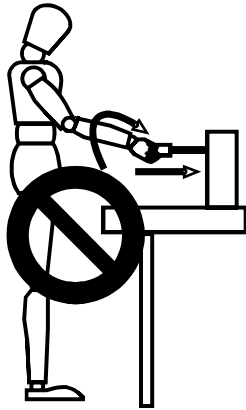

**Reaching & pushing forward with wrist twist.**



**Backhand Push, twisted body, pushing behind, twisting arms.**

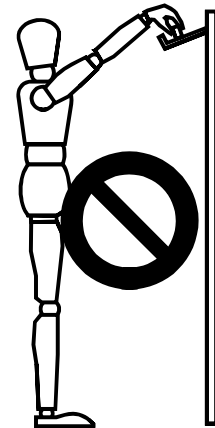

**Reaching Above Shoulders**

## **Anthropometry**

Anthropometry studies the dimensions, weights, and strengths of the human body. This data helps to design effective workstations and spaces.

### **Human Dimensions In Workplace Design**

Humans vary significantly in size and build. In some situations, it is sufficient to design for the smallest or largest likely dimension. In other situations, adjustable benches, chairs or devices are required for the full range of people.

Note that these dimensions are from older studies of North American and primarily Caucasian personnel.

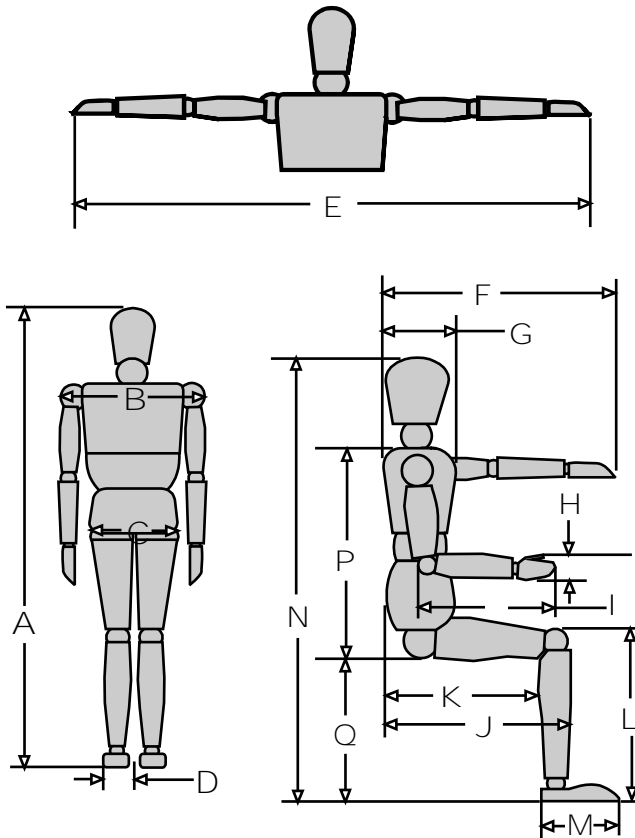

**Selected Anthropometric Dimensions**

ID	DESCRIPTION	MALE					FEMALE				
		MED	SD	MIN	MAX	GP	MED	SD	MIN	MAX	GP
A	Height	69.1	2.44	66.5	77.6	a	63.2	2.48	55	73	d
B	Shoulder Breadth	17.9	0.91	14.6	22.8	a	13.4	1.22	8.7	19.3	d
C	Hip Breadth(Seat)	15.3	1.11	12	21.3	b	14.6	1.04	12.1	20.6	c
C	Hip Breadth(Stand)	13.2	0.73	8.3	15.8	a	15	1.03	11.8	18.9	e
C	Hip Breadth(Seat)	13.9	0.87	11.4	18.1	a					
D	Foot Breadth	3.8	0.19	3.2	4.7	a					
E	Arm Span	70.8	2.94	68.3	82.3	a					
F	Arm Reach	34.6	1.65	27.6	39.8	d	31.8	1.29	28.3	35.4	e
G	Chest Depth	9	0.75	6.7	13	a					
H	Hand Breadth	3.5	0.16	3	4.1	a					
I	Forearm- Hand	18.9	0.81	15.4	22.1						
J	Buttock-Knee	23.6	1.06	18.5	27.6	a	22.6	0.96	19.7	26.7	e
K	Seat Length	18.9	0.96	15.4	23.1	b	18.2	1.04	15.2	22.2	c
L	Sitting Knee Hgt	21.7	0.99	17.3	24.8	a	17.2	1.07			d
M	Foot Length	10.5	0.45	8.9	12.2	a	9.6	0.4	8.9	10.9	e
N	Erect Sit Height*	36	1.29	29.9	40.2	a	34.1	1.02	30.7	34.4	e
P	Shoulder Hgt(Seat)	23.3	1.14	18.9	27.2	a	24.6	3.02			d
Q	Seat Height	19	0.89	15.6	22	b	18.1	0.89	15.4	20.6	c

Notes:

Source: McCormick, 1964

\* Normal Sitting Height is about 2" Less Than Erect Height

Group "c" Data Are Medians, Groups "d" & "e" Data Are Means

Groups:

- a- 4000 Air Force Flying Personnel, Herzberg, Daniels and Churchill
- b- 1959 Civilian Males, Hooten and Staff
- c- 1908 Civilian Females, Hooten and Staff
- d- 10,042 Civilian Females, O'Brien and Shelton
- e- 447 Female Pilots, Randall, Damon, Benton and Pratt

## Reach Zones

One of the most common applications of anthropometrics is the determination of where to place tools, parts, fixtures, controls and other objects. Proper placement reduces WMSD risk and increases operator efficiency. The diagrams below categorize the workspace by four horizontal and four vertical reach zones.

Zones 1 are the most convenient and require the least body movement. The most frequently grasped objects should go in this zone. Most work should also occur in this zone.

Zones 2 can hold objects that do not require fine attention from the operator and, perhaps, are grasped less frequently. Zones 3 are appropriate for infrequent grasps and zones 4 for occasional grasps.

The dimensions below apply to the majority of workers. However, small or short people may have smaller reach zones.

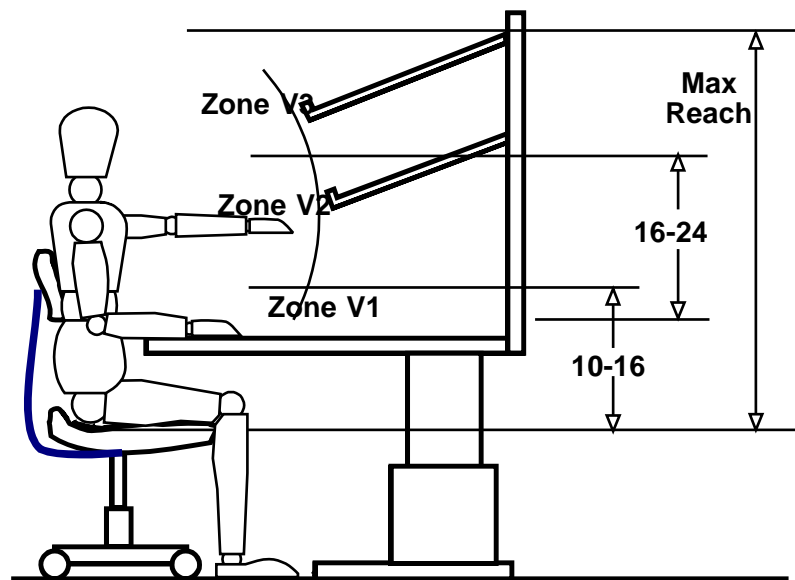
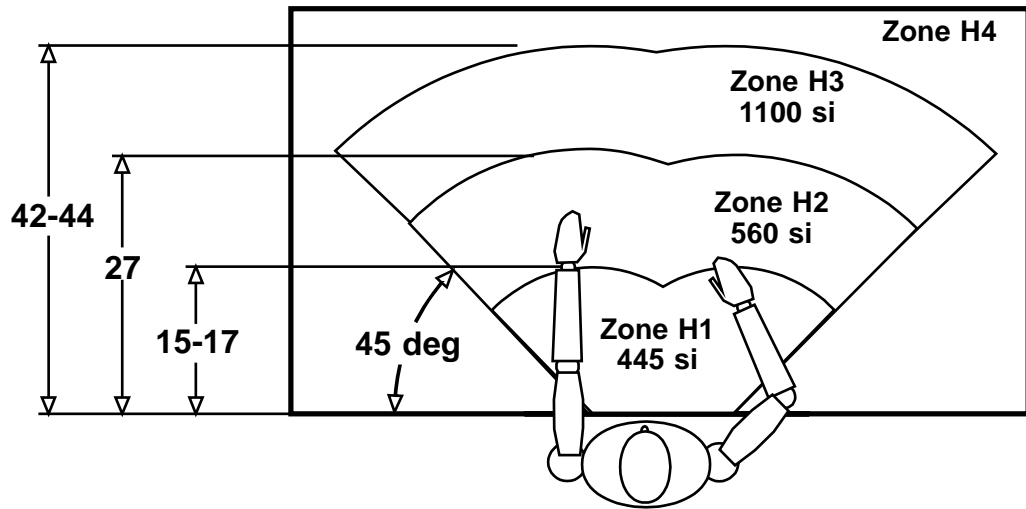



## Typical Work Clearances

This diagram shows typical clearances for various work positions. The three values represent:

- Minimum Recommended Clearance
- Recommended Clearance
- Clearance With Bulky Clothing

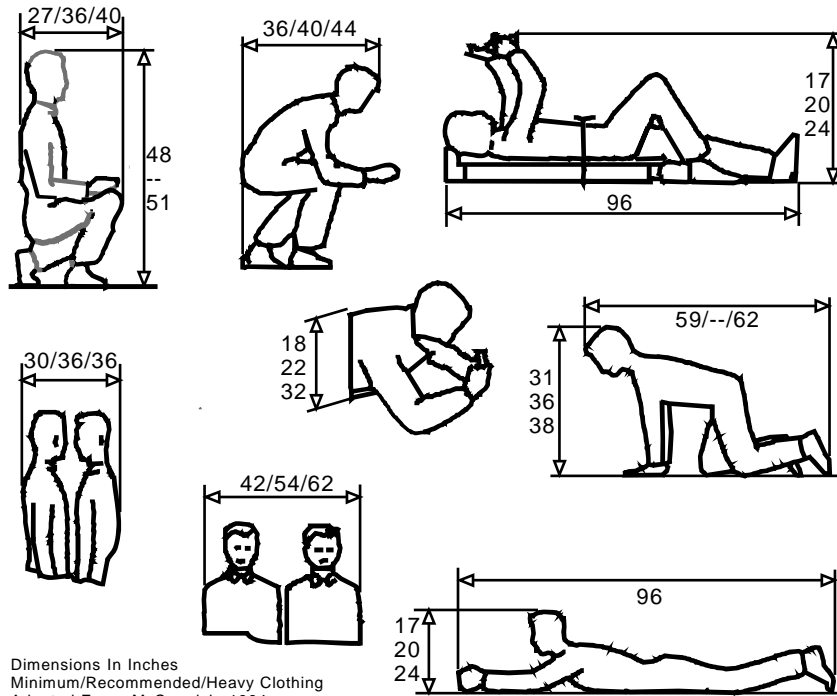

## Principles of Ergonomics

These principles condense ergonomics into simple rules. They are not all-inclusive and do not substitute for in-depth knowledge or common sense. For workstations, refer also to Principles of Motion Economy

### 1.0 Extreme Joint Movements

- Alter the tool or control- bend the tool or handle instead of the wrist.
- Move the part- rotate the part in front of the worker to keep the wrist straight.
- Move the Worker- change the worker's position relative to the part.
- Avoid reaching above shoulder level.
- Avoid reaching behind the body Keep elbows close to the sides.
- Place the work about 2"-4" below the elbow when standing or seated in an erect posture.
- For precise or delicate tasks, place the work surface 4"-8" above elbow height.
- For heavy manual assembly, place the work surface 4"-5" below elbow height.
- Start your design from the working point where the hands spend most of their time.

### 2.0 Excessive Force

- Keeping cutting edges sharp and tools well maintained.
- Spread Force- Alternate hands, use levers instead of buttons.
- Increase Mechanical Advantage- Use stronger muscle groups and long handles.
- Use jigs and fixtures whenever possible.
- Select gloves carefully. They can reduce grip strength up to 15%.

### 3.0 Repetitive Movement

- Task Enlargement- Give workers larger and more varied tasks and increase cycle time.
- Mechanization- Use special tools with ratchets or power drivers. Automation- Allocate repetitive motions to machines.
- Give the operator a neutral posture.
- Allow variation of method to prevent a static posture for extended periods. Permit several working positions
- Re-sequence jobs to reduce repetition
- 

### 4.0 Physiology

- Allow self-pacing of work when possible.
- Allow frequent rest for most active muscles.
- Start new employees at a slower rate.

### 5.0 Hand Tools

- Provide handles.
- Design For minimum muscular effort.
- Power with motors more than muscles.
- Bend the tool and not the wrist.
- Keep the effective weight of the tool low.
- Align the tool center of gravity and the center of the grasping hand.
- Use pistol grips for a horizontal tool axis.
- Use straight grips for a vertical tool axis.
- Use trigger levers rather than buttons.
- Design special use tools if needed.
- Design tools for use by either hand.
- Use A Minimum handle length of 4".
- Use grips that accommodate different size hands.
- Use non-porous, non-slip, & non-conductive grips.
- Spring load pliers and scissors.
- Tools should weigh less than 9 lbs- Suspend heavy/awkward tools.

### 6.0 Position

- **Use a standing position when:**
  - Knee clearance is unavailable.
  - The operator lifts more than 10 pounds.
  - There are high, low, or extended reaches.
  - Operator exerts downward forces- wrapping and packing.
  - The job requires mobility.
- **Use a sit/stand position when:**
  - Repetitive operations have frequent reaches beyond zone 1.
  - Operator performs sitting and standing tasks.
  - Task requires prolonged static effort.
- **Use a sitting position when:**
  - Items for a repetitive, short cycle are in seated workspace.
  - Hands work less than 6" above the surface.
  - Large force is not required.
  - Handling weight is less than 10 lbs.
  - Task includes fine assembly or writing.
  - Operator needs stability and equilibrium.
  - Task requires precise foot control.
  - Operator has extended time in a fixed position

## References

<http://www.ccohs.ca/oshanswers/diseases/rmirsi.htm>

ANSI/HFES100-1988, Human Factors & Ergonomic Society, 1988.

Barnes, Ralph M., Motion and Time Study, Second Edition, John Wiley & Sons, New York, 1940.

Eastman Kodak Company, Ergonomic Design for People at Work, Van Nostrand Reinhold, New York, 1986.

Fraser, M., the Worker At Work, Taylor & Francis, New York, 1989.

Lee, Q, Nelson W., Amundsen, A., & Tuttle, H., Facilities and Workplace Design, Institute of Industrial Engineers, Atlanta, Georgia, 1996.

Woodson, Wesley E. and Conover, Donald W., Human Engineering for Equipment Design 2nd Rev. Edition, University of California Press, Berkely, 1966.

Zandin, Kjell B. and Maynard, Harold B., Industrial Engineering Handbook 5TH Edition, McGraw-Hill, New York, 2001.