



Engineering Fundamentals

Roger Timings



Engineering Fundamentals

This Page Intentionally Left Blank

Engineering Fundamentals

Roger Timings



Newnes

OXFORD AMSTERDAM BOSTON LONDON NEW YORK PARIS
SAN DIEGO SAN FRANCISCO SINGAPORE SYDNEY TOKYO

Newnes
An imprint of Elsevier Science
Linacre House, Jordan Hill, Oxford OX2 8DP
225 Wildwood Avenue, Woburn, MA 01801-2041

First published 2002

Copyright © 2002, Roger Timings. All rights reserved

The right of Roger Timings to be identified as the author of this work has been asserted in accordance with the Copyright, Designs and Patents Act 1988

All rights reserved. No part of this publication may be reproduced in any material form (including photocopying or storing in any medium by electronic means and whether or not transiently or incidentally to some other use of this publication) without the written permission of the copyright holder except in accordance with the provisions of the Copyright, Designs and Patents Act 1988 or under the terms of a licence issued by the Copyright Licensing Agency Ltd, 90 Tottenham Court Road, London, England W1T 4LP. Applications for the copyright holder's written permission to reproduce any part of this publication should be addressed to the publishers

British Library Cataloguing in Publication Data

A catalogue record for this book is available from the British Library

ISBN 0 7506 5609 3

For information on all Newnes publications visit our website at www.newnespress.com

Typeset by Laserwords Private Limited, Chennai, India.
Printed and bound in Great Britain

Contents

	<i>Preface</i>	xi
	<i>Acknowledgements</i>	xii
1 General health and safety (engineering)	1.1 Health, safety and the law	1
	1.2 Employers' responsibilities	3
	1.3 Employees' responsibilities	5
	1.4 Electrical hazards	6
	1.5 Fire fighting	7
	1.6 Fire precautions and prevention	10
	1.7 Accidents	11
	1.8 First aid	14
	1.9 Personal protection	16
	1.10 Hazards in the workplace	20
	1.11 Manual lifting	25
	1.12 Mechanical lifting equipment	27
	1.13 Use of lifting equipment	27
	1.14 Accessories for lifting gear	28
	1.15 Useful knots for fibre ropes	31
	1.16 Transporting loads (trucks)	32
	1.17 Inspection (lifting equipment)	33
	Exercises	34
2 Establishing effective working relationships	2.1 Basic relationships	38
	2.2 Relationships with managers, supervisors and instructors	40
	2.3 Attitude and behaviour	42
	2.4 Implementing company policy	43
	2.5 Creating and maintaining effective working relationships with other people	46
	Exercises	47
3 Handling engineering information	3.1 Selection of information sources	50
	3.2 Interpretation of information (graphical)	51
	3.3 Interpretation of information (tables, charts and schedules)	54
	3.4 Evaluating engineering information	57
	3.5 Recording and processing engineering information	58
	3.6 Methods of record keeping	59
	3.7 Communications (miscellaneous)	60
	Exercises	63

4 Engineering materials and heat treatment	4.1	States of matter	65
	4.2	Properties of materials	66
	4.3	Classification of materials	73
	4.4	Ferrous metals (plain carbon steels)	73
	4.5	Ferrous metals (alloy steels)	76
	4.6	Ferrous metals (cast irons)	79
	4.7	Abbreviations	79
	4.8	British standards for wrought steels	80
	4.9	Non-ferrous metals and alloys	81
	4.10	Workshop tests for the identification of metals	87
	4.11	Non-metals (natural)	87
	4.12	Non-metals (synthetic)	89
	4.13	Forms of supply	92
	4.14	Heat treatment processes (introduction)	94
	4.15	Heat treatment processes (safety)	94
	4.16	The heat treatment of plain carbon steels	97
	4.17	The heat treatment of non-ferrous metals and alloys	109
	4.18	Heat treatment furnaces	110
	4.19	Temperature measurement	115
	4.20	Atmosphere control	118
	Exercises	119	
5 Engineering drawing	5.1	Engineering drawing (introduction)	123
	5.2	First angle orthographic drawing	124
	5.3	Third angle orthographic drawing	127
	5.4	Conventions	129
	5.5	Redundant views	133
	5.6	Dimensioning	134
	5.7	Toleranced dimensions	137
	5.8	Sectioning	138
	5.9	Machining symbols	140
	5.10	Types of engineering drawings	141
	5.11	Pictorial views	144
	5.12	Sketching	147
	Exercises	149	
6 Measuring	6.1	Introduction	155
	6.2	Linear measurement	155
	6.3	Measuring angles	170
	6.4	Miscellaneous measurements	175
	6.5	Limits and fits	177
	6.6	Classes of fit	179
	6.7	Accuracy	180
	6.8	Terminology of measurement	183
		Exercises	184
	Answers	186	

7 Marking out	7.1	Marking-out equipment (tools for making lines)	188
	7.2	Marking-out equipment (tools for providing guidance)	194
	7.3	Marking-out equipment (tools for providing support)	196
	7.4	The purposes, advantages and disadvantages of manual marking out	200
	7.5	Types of datum	201
	7.6	Techniques for marking out	203
			Exercises
8 Basic bench fitting	8.1	Relative merits and disadvantages of using hand tools	218
	8.2	The fitter's bench	219
	8.3	The metal cutting wedge	220
	8.4	The angles of a wedge-shaped cutting tool and their terminology	221
	8.5	The application of the basic cutting angles to hand tools	223
	8.6	Chipping	224
	8.7	Hammers	226
	8.8	Filing	227
	8.9	The hacksaw	231
	8.10	Screw thread applications	233
	8.11	Cutting internal screw threads (use of taps)	236
	8.12	Cutting external screw threads (use of dies)	239
	8.13	Hand reamers and reaming	241
	8.14	Tools used in assembly and dismantling	242
	8.15	Preparation of hand tools	248
	8.16	Making a link	249
	8.17	Checking the link	252
		Exercises	253
9 Drilling techniques and drilling machines	9.1	The twist drill	257
	9.2	Twist drill cutting angles	259
	9.3	Twist drill cutting speeds and feeds	260
	9.4	Twist drill failures and faults	263
	9.5	Blind hole drilling	265
	9.6	Reamers and reaming	266
	9.7	Miscellaneous operations	268
	9.8	Toolholding	270
	9.9	Workholding	272
	9.10	The basic alignments of drilling machines	275
	9.11	The bench (sensitive) drilling machine	276
	9.12	The pillar drilling machine	277
		Exercises	278
10 Centre lathe and turning techniques	10.1	The safe use of machine tools	281
	10.2	Constructional features of the centre lathe	285

	10.3	Main movements and alignments	289
	10.4	Types of spindle nose	292
	10.5	Starting up and closing down the machine	294
	10.6	Workholding devices (centres)	295
	10.7	Workholding devices (taper mandrel)	298
	10.8	Workholding devices (self-centring chuck)	300
	10.9	Workholding devices (collets)	302
	10.10	Workholding devices (four-jaw, independent chuck)	303
	10.11	Workholding devices (faceplate)	306
	10.12	Use of steadies	307
	10.13	Lathe tool profiles	309
	10.14	Concentricity	309
	10.15	Taper turning	310
	10.16	Hole production	312
	10.17	Parting off	315
	10.18	Cutting screw threads	316
	10.19	Knurling	318
	10.20	Chip formation and the geometry of lathe tools	318
	10.21	Cutting lubricants and coolants	322
	10.22	Tool height	323
	10.23	Relationship between depth of cut and feed rates as applied to turning operations	325
	10.24	Cutting speeds as applied to turning operations	328
	10.25	The production of some typical turned components Exercises	330 335
11	Milling machines and milling techniques		
	11.1	Safety	342
	11.2	The milling process	343
	11.3	The horizontal spindle milling machine	346
	11.4	The vertical spindle milling machine	347
	11.5	Types of milling cutters and their applications	350
	11.6	Cutter mounting (horizontal milling machine)	352
	11.7	Cutter mounting (vertical milling machine)	355
	11.8	Workholding	357
	11.9	Cutting speeds and feeds	362
	11.10	Squaring up a blank on a horizontal milling machine	365
	11.11	Milling a step (horizontal milling machine)	367
	11.12	Milling a step (vertical milling machine)	368
	11.13	Milling a slot (horizontal milling machine)	368
	11.14	Milling an angular surface Exercises	369 371
12	Grinding machines and processes		
	12.1	Safety when grinding	376
	12.2	Fundamental principles of grinding	379
	12.3	Grinding wheel specification	380
	12.4	Grinding wheel selection	384
	12.5	Grinding wheel defects	385

12.6	Grinding wheel dressing and truing	386
12.7	Grinding wheel balancing	387
12.8	The double-ended off-hand grinding machine	389
12.9	Resharpener hand tools and single point cutting tools	392
12.10	Surface grinding machine	393
12.11	Workholding	395
12.12	Mounting a magnetic chuck on the worktable	398
12.13	Grinding a flat surface	400
	Exercises	402
	<i>Index</i>	405

This Page Intentionally Left Blank

Preface

This book is designed to provide an accessible course in the basic engineering principles and applications required in a wide range of vocational courses. No prior knowledge of engineering is assumed.

I trust that *Engineering Fundamentals* will be found to be a worthy successor to my previous introductory books on general and mechanical engineering. As well as offering up-to-date best practice and technical information, this new title has been fully matched to the latest courses, in particular Level 2 NVQs within the Performing Engineering Operations scheme from EMTA and City & Guilds (scheme 2251). Guidance on the depth of treatment has been taken from the EMTA *Industry Standards of Competence* documents. EMTA are the NTO for the development of NVQs (the UK's National Vocational Qualifications) in all aspects of engineering.

All the chapters end with a selection of exercises. These will help with assessing the trainees' performance criteria for the underpinning knowledge and understanding that is an essential part of their training.

Finally, the author and publishers are grateful to Training Publications Ltd and Pearson Educational Ltd for allowing the reproduction and adaptation of their illustrations and material in this text.

Roger Timings

Acknowledgements

The author and publishers wish to thank the following organisations for permission to reproduce their copyright material:

British Standards Institution (BSI): Figures 1.6, 1.7, 1.8, 1.9, 1.32, 5.7, 5.8, 5.9, 5.10, 5.11, 5.12, 5.17, 5.33, 9.2, 9.8, 9.9, 9.10, 9.11, 9.12.

Cincinnati Milacron Ltd: Figure 11.2(c and d).

Myford Ltd: Figure 5.21.

Pearson Education Ltd: Figures 1.5, 1.12, 1.13, 1.14, 1.15, 1.17, 1.22, 1.25(b), 1.27, 1.29, 1.30, 1.31, 2.1, 2.2, 2.3, 3.1, 3.2, 3.3, 3.4, 3.5, 3.6, 3.7, 3.8, 4.1, 4.2, 4.3, 4.4, 4.5, 4.6, 4.7, 4.8, 4.11, 4.12, 4.13, 4.15, 4.17, 4.18, 4.19, 4.20, 4.21, 4.22, 4.23, 4.24, 4.25, 4.26, 5.1, 5.2, 5.3, 5.4, 5.5, 5.6, 5.13, 5.14, 5.15, 5.16, 5.18, 5.19, 5.20, 5.22, 5.23, 5.24, 5.27, 5.28, 5.29, 5.30, 5.31, 5.32, 5.24, 5.25, 5.26, 6.1, 6.4, 6.5, 6.8, 6.9, 6.10, 6.11, 6.12, 6.13, 6.14, 6.15, 6.16, 6.17, 6.19, 6.20, 6.21, 6.22, 6.23, 6.25, 6.26, 6.27, 6.28, 6.29, 6.30, 6.31, 6.32, 7.1, 7.5(a & b), 7.7, 7.8, 7.9, 7.11, 7.14, 7.15, 7.16, 7.17, 7.18, 7.19, 7.20, 7.22, 7.23, 7.24, 7.25, 7.26, 7.27, 7.28, 7.29, 7.30, 7.31, 7.32, 7.33, 8.1, 8.2, 8.3, 8.4, 8.5, 8.6, 8.7, 8.8, 8.9, 8.12, 8.13, 8.16, 8.17, 8.18, 8.19, 8.20, 8.21, 8.24, 8.26, 8.27, 8.28, 8.32, 8.33, 8.34, 8.35, 8.36, 8.37, 8.38, 8.39, 8.40, 8.41, 8.42, 8.743, 9.1, 9.3, 9.4, 9.5, 9.6, 9.7, 9.13, 9.14, 9.15, 9.16, 9.17, 9.18, 9.19, 9.29, 9.21, 9.22, 10.3, 10.4, 10.5, 10.6, 10.7, 10.8(a), 10.9(a), 10.10(a), 10.11, 10.13, 10.14, 10.16, 10.17, 10.18, 10.19, 10.20, 10.21, 10.22, 10.23, 10.24, 10.25, 10.26, 10.27, 10.28, 10.29, 10.30, 10.31, 10.32, 10.33, 10.34, 10.35, 10.36(b), 10.37, 10.38, 10.39, 10.40, 10.41, 10.42, 10.43, 10.44, 10.45, 10.46, 10.47, 10.48, 10.49, 10.50, 10.51, 10.52, 10.53, 10.54, 10.55, 10.56, 10.57, 10.58, 10.59, 11.4, 11.5, 11.6, 11.7, 11.8, 11.9, 11.10, 11.11, 11.12, 11.13, 11.14, 11.15, 11.23, 11.24, 11.25, 11.26, 11.27, 11.29, 11.30, 11.31, 11.32, 11.33, 11.34, 11.35, 11.36, 11.37, 12.1, 12.2, 12.3, 12.4, 12.6, 12.7, 12.8, 12.9, 12.10, 12.12, 12.13, 12.14, 12.15.

Richard Lloyd (Galtona) Ltd: Figure 11.3 (a and b).

Silvaflame Co. Ltd: Figures 10.1, 11.1(b).

Spear and Jackson plc (Moore and Wright, James Neil, Neil Magnetics): Figures 6.2, 6.3, 6.7, 6.18, 7.4, 7.6, 7.10, 12.16, 12.17, 12.18.

Training Publications Ltd: Figures 1.1, 1.2, 1.3, 1.4, 1.10, 1.11, 1.18, 1.19, 1.20, 1.21, 1.23, 1.24, 1.25(a), 1.26, 1.28, 1.33, 4.9, 4.16, 5.25, 5.26, 6.24, 7.2, 7.3, 7.5(c), 7.12, 7.13, 7.21, 8.10, 8.11, 8.14, 8.15, 8.22, 8.23, 8.25, 8.29, 8.30, 8.31, 10.12, 10.27, 11.16, 11.17, 11.18, 11.19, 11.20, 11.21(b), 11.22(b), 11.28, 12.11, 12.19, 12.20, 12.21.

WDS (Production Equipment) Ltd: Figures 10.15, 10.36(a), 11.21(a), 11.22(a), 12.5.

600 Group (Colchester Lathes): Figures 10.2, 10.25, 10.26.

1 General health and safety (engineering)

When you have read this chapter you should understand:

- The statutory requirements for general health and safety at work.
- Accident and first aid procedures.
- Fire precautions and procedures.
- Protective clothing and equipment.
- Correct manual lifting and carrying techniques.
- How to use lifting equipment.
- Safe working practices.

1.1 Health, safety and the law

1.1.1 Health and Safety at Work, etc. Act

It is essential to observe safe working practices not only to safeguard yourself, but also to safeguard the people with whom you work. The Health and Safety at Work, etc. Act provides a comprehensive and integrated system of law for dealing with the health, safety and welfare of workpeople and the general public as affected by industrial, commercial and associated activities.

The Act places the responsibility for safe working equally upon:

- the employer;
- the employee (that means you);
- the manufacturers and suppliers of materials, goods, equipment and machinery.

1.1.2 Health and Safety Commission

The Act provides for a full-time, independent chairman and between six and nine part-time commissioners. The commissioners are made up of three trade union members appointed by the TUC, three management members appointed by the CBI, two local authority members, and one independent member. The commission has taken over the responsibility previously held by various government departments for the control of most occupational health and safety matters. The commission is also responsible for the organization and functioning of the Health and Safety Executive.

1.1.3 Health and Safety Executive

The inspectors of the Health and Safety Executive (HSE) have very wide powers. Should an inspector find a contravention of one of the provisions of earlier Acts or Regulations still in force, or a contravention of the Health and Safety at Work, etc. Act, the inspector has three possible lines of action available.

Prohibition Notice

If there is a risk of serious personal injury, the inspector can issue a *Prohibition Notice*. This immediately stops the activity that is giving rise to the risk until the remedial action specified in the notice has been taken to the inspector's satisfaction. The prohibition notice can be served upon the person undertaking the dangerous activity, or it can be served upon the person in control of the activity at the time the notice is served.

Improvement Notice

If there is a legal contravention of any of the relevant statutory provisions, the inspector can issue an *Improvement Notice*. This notice requires the infringement to be remedied within a specified time. It can be served on any person on whom the responsibilities are placed. The latter person can be an employer, employee or a supplier of equipment or materials.

Prosecution

In addition to serving a Prohibition Notice or an Improvement Notice, the inspector can prosecute any person (including an employee – you) contravening a relevant statutory provision. Finally the inspector can seize, render harmless or destroy any substance or article which the inspector considers to be the cause of imminent danger or personal injury.

Thus every employee must be a fit and trained person capable of carrying out his or her assigned task properly and safely. Trainees must work under the supervision of a suitably trained, experienced worker or instructor. By law, every employee must:

- Obey all the safety rules and regulations of his or her place of employment.
- Understand and use, as instructed, the safety practices incorporated in particular activities or tasks.
- Not proceed with his or her task if any safety requirement is not thoroughly understood; guidance must be sought.
- Keep his or her working area tidy and maintain his or her tools in good condition.
- Draw the attention of his or her immediate supervisor or the safety officer to any potential hazard.

- Report all accidents or incidents (even if injury does not result from the incident) to the responsible person.
- Understand emergency procedures in the event of an accident or an alarm.
- Understand how to give the alarm in the event of an accident or an incident such as fire.
- Co-operate promptly with the senior person in charge in the event of an accident or an incident such as fire.

Therefore, safety, health and welfare are very personal matters for a young worker, such as yourself, who is just entering the engineering industry. This chapter sets out to identify the main hazards and suggests how they may be avoided. Factory life, and particularly engineering, is potentially dangerous and you must take a positive approach towards safety, health and welfare.

1.1.4 Further legislation and regulations concerning safety

In addition to the Health and Safety at Work, etc. Act, the following are examples of legislation and regulations that also control the conditions under which you work and the way in which you work (behaviour).

- Factories Act 1961
- Safety Representatives and Safety Committees Regulations 1977
- Notification of Accidents and General Occurrences Regulations 1980
- Management of Health and Safety at Work Regulations 1992
- Protection of Eyes Regulations 1974
- Electricity at Work Regulations 1989
- Low Voltage Electrical Equipment (Safety) Regulations 1989. This includes voltage ranges of 50 volts to 1000 volts (AC) and 75 volts to 1500 volts (DC)
- Abrasive Wheels Regulations 1970
- Noise at Work Regulations 1989

You are not expected to have a detailed knowledge of all this legislation, but you are expected to know of its existence, the main topic areas that it covers, and how it affects your working conditions, your responsibilities, and the way in which you work. There are many other laws and regulations that you will come across depending upon the branch of the engineering industry in which you work.

1.2 Employers' responsibilities

All employers must, by law, maintain a safe place to work. To fulfil all the legal obligations imposed upon them, employers must ensure that:

- The workplace must be provided with a safe means of access and exit so that in the case of an emergency (such as fire) no one will be trapped. This is particularly important when the workplace is not at ground level. Pedestrian access and exits should be segregated from lorries delivering materials or collecting finished work. The premises must be kept in good repair. Worn floor coverings and stair treads are a major source of serious falls.
- All plant and equipment must be safe so that it complies with the *Machinery Directive*. It must be correctly installed and properly maintained. The plant and any associated cutters and tools must also be properly guarded.
- Working practices and systems are safe and that, where necessary, protective clothing is provided.
- A safe, healthy and comfortable working environment is provided, and that the temperature and humidity is maintained at the correct levels for the work being undertaken.
- There is an adequate supply of fresh air, and that fumes and dust are either eliminated altogether or are reduced to an acceptable and safe level.
- There is adequate and suitable natural and artificial lighting, particularly over stairways.
- There is adequate and convenient provision for washing and sanitation.
- There are adequate first aid facilities under the supervision of a qualified person. This can range from a first aid box under the supervision of a person trained in basic first aid procedures for a small firm, to a full scale ambulance room staffed by professionally qualified medical personnel in a large firm.
- Provision is made for the safe handling, storing, siting, and transportation of raw materials, work in progress and finished goods awaiting delivery.
- Provision for the safe handling, storing, siting, transportation and use of dangerous substances such as compressed gases (e.g. oxygen and acetylene), and toxic and flammable solvents.
- There is a correct and legal system for the reporting of accidents and the logging of such accidents in the *accident register*.
- There is a company policy for adequate instruction, training and supervision of employees. This must not only be concerned with safety procedures but also with good working practices. Such instruction and training to be updated at regular intervals.
- There is a safety policy in force. This safety policy must be subject to regular review. One of the more important innovations of the Health and Safety at Work, etc. Act is contained in section 2(4) which provides for the appointment of safety representatives from amongst the employees, who will represent them in consultation with the employers, and have other prescribed functions.

- Where an employer receives a written request from at least two safety representatives to form a *safety committee* the employer shall, after consulting with the applicants and representatives of other recognized unions (if applicable) whose members work in the workplace concerned, establish a safety committee within the period of three months after the request. The employer must post a notice of the composition of the committee and the workplaces covered. The notice must be positioned where it may be easily read by the employees concerned.
 - Membership of the safety committee should be settled by consultation. The number of management representatives should not exceed the number of safety representatives. Where a company doctor, industrial hygienist or safety officer/adviser is employed they should be ex-officio members of the committee.
 - Management representation should be aimed at ensuring the necessary knowledge and expertise to provide accurate information on company policy, production needs and technical matters in relation to premises, processes, plant, machinery and equipment.
-

1.3 Employees' responsibilities

All employees (including you) are as equally responsible for safety as are their employers. Under the Health and Safety at Work, etc. Act, employees are expected to take reasonable care for their own health and safety together with the health and safety of other people with whom they work, and members of the public who are affected by the work being performed.

Further, the misuse of, or interference with, equipment provided by an employer for health and safety purposes is a criminal offence. It is up to all workers to develop a sense of *safety awareness* by following the example set by their instructors. Regrettably not all older workers observe the safety regulations as closely as they should. Take care who you choose for your 'role model'. The basic requirements for safe working are to:

- Learn the safe way of doing each task. This is usually the correct way.
 - Use the safe way of carrying out the task in practice.
 - Ask for instruction if you do not understand a task or have not received previous instruction.
 - Be constantly on your guard against careless actions by yourself or by others.
 - Practise good housekeeping at all times.
 - Co-operate promptly in the event of an accident or a fire.
 - Report all accidents to your instructor or supervisor.
 - Draw your instructor's or your supervisor's attention to any potential hazard you have noticed.
-

1.4 Electrical hazards The most common causes of electrical shock are shown in Fig. 1.1. The installation and maintenance of electrical equipment must be carried out only by a fully trained and registered electrician. The installation and equipment must conform to international standards and regulations as laid down in safety legislation and the codes of practice and regulations published by the Institution of Electrical Engineers (IEE).

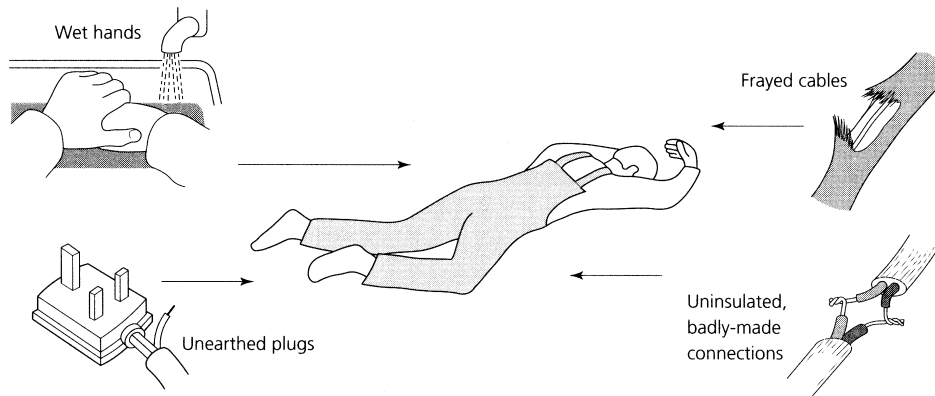


Figure 1.1 *Causes of electric shock*

An electric shock from a 240 volt single-phase supply (lighting and office equipment) or a 415 volt three-phase supply (most factory machines) can easily kill you. Even if the shock is not sufficiently severe to cause death, it can still cause serious injury. The sudden convulsion caused by the shock can throw you from a ladder or against moving machinery. To reduce the risk of shock, all electrical equipment should be earthed or double insulated. Further, portable power tools should be fed from a low-voltage transformer at 110 volts. The power tool must be suitable for operating at such a voltage. The transformer itself should be protected by a circuit breaker containing a residual current detector.

The fuses and circuit breakers designed to protect the supply circuitry to the transformer react too slowly to protect the user from electric shock. The electrical supply to a portable power tool should, therefore, be protected by a residual current detector (RCD). Such a device compares the magnitudes of the current flowing in the live and neutral conductors supplying the tool. Any leakage to earth through the body of the user or by any other route will upset the balance between these two currents. This results in the supply being immediately disconnected. The sensitivity of residual current detectors is such that a difference of only a few milliamperes is sufficient to cut off the supply and the time delay is only a few microseconds. Such a small current applied for such a short time is not dangerous.

In the event of rendering first aid to the victim of electrical shock, great care must be taken when pulling the victim clear of the fault which caused the shock. The victim can act as a conductor and thus, in turn,

electrocute the rescuer. If the supply cannot be quickly and completely disconnected, always pull the victim clear by his or her clothing which, if dry, will act as an insulator. If in doubt, hold the victim with a plastic bag or cloth known to be dry. Never touch the victim's bare flesh until the victim is clear of the electrical fault. Artificial respiration must be started immediately the victim has been pulled clear of the fault or the live conductor.

1.5 Fire fighting

Fire fighting is a highly skilled operation and most medium and large firms have properly trained teams who can contain the fire locally until the professional brigade arrives. The best way you can help is to learn the correct fire drill, both how to give the alarm and how to leave the building. It requires only one person to panic and run in the wrong direction to cause a disaster.

In an emergency never lose your head and panic.

Smoke is the main cause of panic. It spreads quickly through a building, reducing visibility and increasing the risk of falls down stairways. It causes choking and even death by asphyxiation. Smoke is less dense near the floor: as a last resort crawl. To reduce the spread of smoke and fire, keep fire doors closed at all times but never locked. The plastic materials used in the finishes and furnishings of modern buildings give off highly toxic fumes. Therefore it is best to leave the building as quickly as possible and leave the fire fighting to the professionals who have breathing apparatus. *Saving human life is more important than saving property.*

If you do have to fight a fire there are some basic rules to remember. A fire is the rapid oxidation (burning) of flammable materials at relatively high temperatures. Figure 1.2 shows that removing the air (oxygen), or the flammable materials (fuel), or lowering the temperature will result in the fire ceasing to burn. It will go out. It can also be seen from Fig. 1.2 that different fires require to be dealt with in different ways.

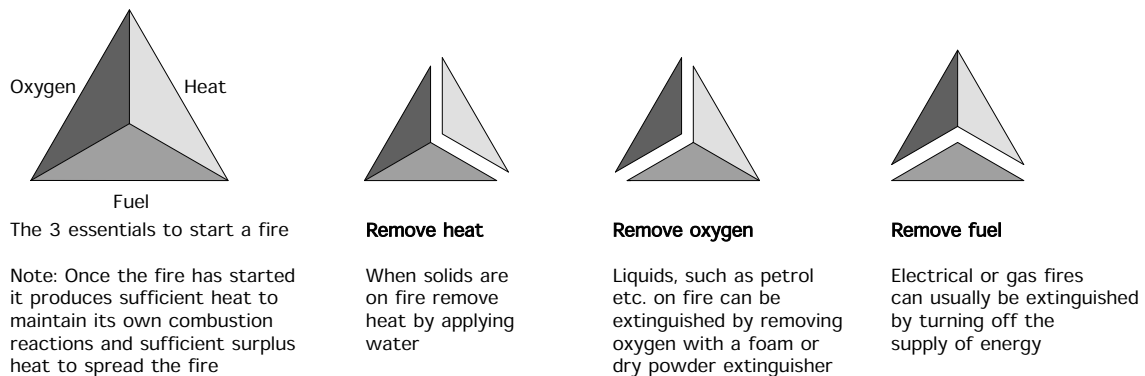


Figure 1.2 How to remove each of the three items necessary to start a fire. (Note: Once the fire has started it produces sufficient heat to maintain its own combustion reaction and sufficient surplus heat to spread the fire)

1.5.1 Fire extinguishers

The normally available fire extinguishers and the types of fire they can be used for are as follows.

Water

Used in large quantities water reduces the temperature and puts out the fire. The steam generated also helps to smother the flames as it displaces the air and therefore the oxygen essential to the burning process. However, for various technical reasons, water should be used only on burning solids such as wood, paper and some plastics. A typical hose point and a typical pressurized water extinguisher is shown in Fig. 1.3.

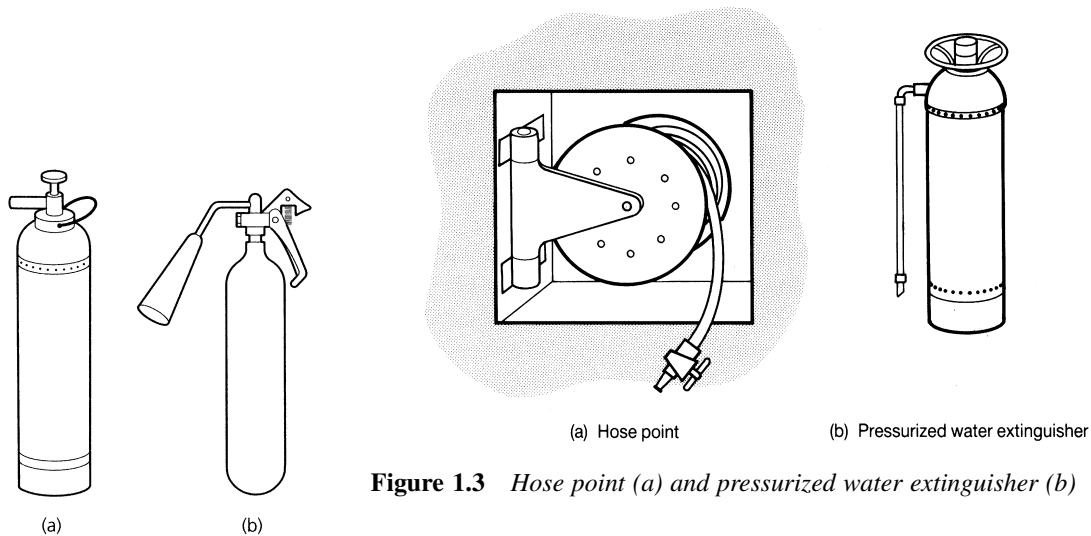


Figure 1.3 *Hose point (a) and pressurized water extinguisher (b)*

Foam extinguishers

These are used for fighting oil and chemical fires. The foam smothers the flames and prevents the oxygen in the air from reaching the burning materials at the seat of the fire. Water alone cannot be used because oil floats on the water and this spreads the area of the fire. A typical foam extinguisher is shown in Fig. 1.4(a).

Note: Since both water and foam are electrically conductive, do not use them on fires associated with electrical equipment or the person wielding the hose or the extinguisher will be electrocuted.

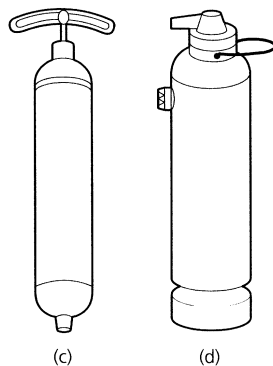


Figure 1.4 *Fire extinguishers: (a) foam; (b) CO₂; (c) vaporizing liquid; (d) dry powder*

Carbon dioxide (CO₂) extinguishers

These are used on burning gases and vapours. They can also be used for oil and chemical fires in confined places. The carbon dioxide gas replaces the air and smothers the fire. It can be used only in confined places, where it cannot be displaced by draughts.

Note: If the fire cannot breathe neither can you, so care must be taken to evacuate all living creatures from the vicinity before operating the extinguisher. Back away from the bubble of CO₂ gas as you operate the extinguisher, do not advance towards it. Figure 1.4(b) shows a typical CO₂ extinguisher.

Vaporizing liquid extinguishers

These include CTC, CBM and BCF extinguishers. The heat from the fire causes rapid vaporization of the liquid sprayed from the extinguisher and this vapour displaces the air and smothers the fire. Since a small amount of liquid produces a very large amount of vapour, this is a very efficient way of producing the blanketing vapour. Any vapour that will smother the fire will also smother all living creatures which must be evacuated before using such extinguishers. As with CO₂ extinguishers always back away from the bubble of vapour, never advance into it. Vaporizing liquid extinguishers are suitable for oil, gas, vapour and chemical fires. Like CO₂ extinguishers, vaporizing liquid extinguishers are safe to use on fires associated with electrical equipment. A typical example of a vaporizing liquid extinguisher is shown in Fig. 1.4(c).

Dry powder extinguishers

These are suitable for small fires involving flammable liquids and small quantities of solids such as paper. They are also useful for fires in electrical equipment, offices and kitchens since the powder is not only non-toxic, it can be easily removed by vacuum cleaning and there is no residual mess. The active ingredient is powdered sodium bicarbonate (baking powder) which gives off carbon dioxide when heated. A typical example of a dry powder extinguisher is shown in Fig. 1.4(d).

1.5.2 General rules governing the use of portable extinguishers

- Since fire spreads quickly, a speedy attack is essential if the fire is to be contained.
- Sound the alarm immediately the fire is discovered.
- Send for assistance before attempting to fight the fire.
- Remember
 - (a) Extinguishers are provided to fight only small fires.
 - (b) Take up a position between the fire and the exit, so that your escape cannot be cut off.
 - (c) *Do not* continue to fight the fire if
 - (i) it is dangerous to do so
 - (ii) there is any possibility of your escape route being cut off by fire, smoke, or collapse of the building

- (iii) the fire spreads despite your efforts
- (iv) toxic fumes are being generated by the burning of plastic furnishings and finishes
- (v) there are gas cylinders or explosive substances in the vicinity of the fire.

If you have to withdraw, close windows and doors behind you wherever possible, but not if such actions endanger your escape. Finally, ensure that all extinguishers are recharged immediately after use.

1.6 Fire precautions and prevention

1.6.1 Fire precautions

It is the responsibility of employers and their senior management (duty of care) to ensure the safety of their employees in the event of fire. The following precautions should be taken.

- Ensure ease of exit from the premises at all times – emergency exits must not be locked or obstructed.
- Easy access for fire appliances from the local brigade.
- Regular inspection of the plant, premises and processes by the local authority fire brigade's fire prevention officer. No new plant or processes involving flammable substances should be used without prior notification and inspection by the fire prevention officer.
- The above point also applies to the company's insurance inspector.
- Regular and frequent fire drills must be carried out and a log kept of such drills including the time taken to evacuate the premises. A roll call of all persons present should be taken immediately the evacuation is complete. A meeting of the safety committee should be called as soon as possible after a fire drill to discuss any problems, improve procedures and to learn lessons from the exercise.

1.6.2 Fire prevention

Prevention is always better than cure, and fire prevention is always better than fire fighting. Tidiness is of paramount importance in reducing the possibility of outbreaks of fire. Fires have small beginnings and it is usually amongst accumulated rubbish that many fires originate. So you should make a practice of constantly removing rubbish, shavings, off-cuts, cans, bottles, waste paper, oily rags, and other unwanted materials to a safe place at regular intervals. Discarded foam plastic packing is not only highly flammable, but gives off highly dangerous toxic fumes when burnt.

Highly flammable materials should be stored in specially designed and equipped compounds away from the main working areas. Only minimum quantities of such materials should be allowed into the workshop at a time,

and then only into *non-smoking zones*. The advice of the local authority fire brigade's fire prevention officer should also be sought.

It is good practice to provide metal containers with air-tight hinged lids with proper markings as to the type of rubbish they should contain since some types of rubbish will ignite spontaneously when mixed. The lids of the bins should be kept closed so that, if a fire starts, it will quickly use up the air in the bin and go out of its own accord without doing any damage.

1.7 Accidents

Accidents do not happen, they are caused. There is not a single accident that could not have been prevented by care and forethought on somebody's part. Accidents can and must be prevented. They cost millions of lost man-hours of production every year, but this is of little importance compared with the immeasurably cost in human suffering.

In every eight-hour shift nearly one hundred workers are the victims of industrial accidents. Many of these will be blinded, maimed for life, or confined to a hospital bed for months. At least two of them will die. Figure 1.5 shows the main causes of accidents.

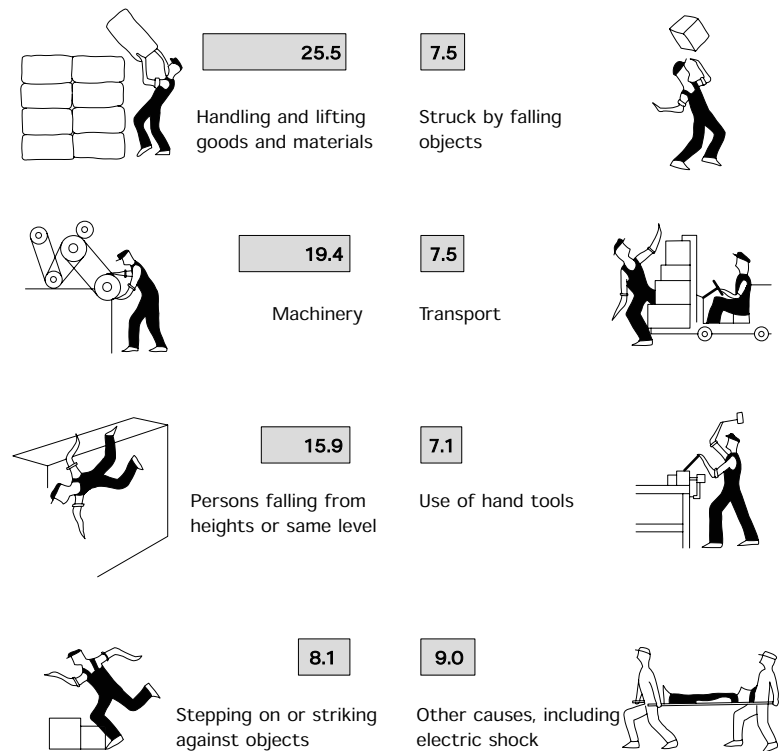


Figure 1.5 Average national causes of industrial accidents (by per cent of all accidents)

1.7.1 Accident procedure

You must learn and obey the accident procedures for your company.

- Report all accidents, no matter how small and trivial they seem, to your supervisor, instructor or tutor. Record your report and details of the incident on an accident form.
- Receive first-aid treatment from a *qualified* person, or your company's medical centre, depending upon the size of your company and its policy.

It is important that you follow the procedures laid down by your company since the accident register has to be produced on request by any HSE inspector visiting your company. Failure to log all accidents is an offence under the Health and Safety at Work, etc. Act. Act and can lead to prosecution in the courts. Also if at some future date you had to seek compensation as a result of the accident, your report is important evidence.

1.7.2 Warning signs and labels

You must be aware of the warning signs and their meanings. You must also obey such signs. To disregard them is an offence under the Health and Safety at Work, etc. Act. Warning signs are triangular in shape and all the sides are the same length. The background colour is *yellow* and there is a *black* border. In addition to warning signs there are also *warning labels*. Figure 1.6 shows some typical warning signs and warning labels. It also gives their meanings.

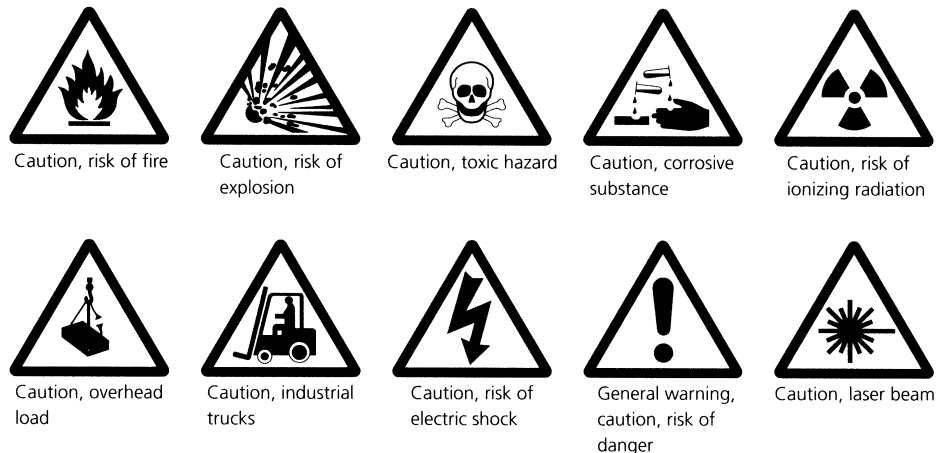


Figure 1.6 *Warning signs*

Prohibition signs

You can recognize these signs as they have a red circular band and a red crossbar on a white background. Figure 1.7 shows five typical prohibition



Figure 1.7 *Prohibition signs*

signs. These signs indicate activities that are *prohibited* at all times. They *must be obeyed*, you have no option in the matter. To disregard them is an offence in law, as you would be putting yourself and others at considerable risk.

Mandatory signs

You can recognize these signs as they have a blue background colour. The symbol must be white. Figure 1.8 shows five typical mandatory signs. These signs indicate things that *you must do* and precautions that *you must take*. These signs *must be obeyed*, you have no option in the matter. To disregard them is an offence in law as, again, you would be putting yourself at considerable risk.



Figure 1.8 *Mandatory signs*

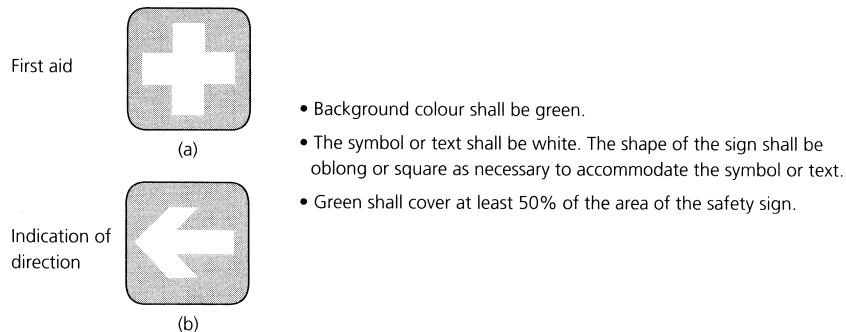


Figure 1.9 *Safe condition signs*

Safe condition signs

In addition to the signs discussed so far that tell you what to look out for, what you must do and what you must not do, there are also signs that tell you what is safe. These have a white symbol on a green background. The example shown in Fig. 1.9(a) indicates a first aid post or an ambulance room. The example shown in Fig. 1.9(b) indicates a safe direction in which to travel.

1.8 First aid

Accidents can happen anywhere at any time. They can happen in the home and in the streets as well as in the workshops of industry. The injuries caused by such accidents can range from minor cuts and bruises to broken bones and life threatening injuries. It is a very good idea to know what to do in an emergency.

- You must be aware of the accident procedure.
- You must know where to find your nearest first aid post.
- You must know the quickest and easiest route to the first aid post.
- You must know who is the *qualified* first aid person on duty (if he/she is a part-time person, then where he/she can be found).

First aid should be administered only by a qualified person. Unfortunately in this day and age, more and more people are being encouraged to seek compensation through the courts of law. Complications resulting from amateurish but well-intentioned and well-meaning attempts at first aid on your part could result in you being sued for swingeing damages.

1.8.1 In the event of an emergency

If you are first on the scene of a serious incident, but you are not a trained first aider:

- Remain calm.
- Get help quickly by sending for the appropriate skilled personnel.
- Act and speak in a calm and confident manner to give the casualty confidence.
- Do not attempt to move the casualty.
- Do not administer fluids.
- Hand over to the experts as quickly as possible.

Minor wounds

Prompt first aid can help nature heal small wounds and deal with germs. If you have to treat yourself then wash the wound clean and apply a plaster. However, you must seek medical advice if:

- there is a foreign body embedded in the wound;
- there is a special risk of infection (such as a dog bite or the wound has been caused by a dirty object);
- a non-recent wound shows signs of becoming infected.

Sometimes there can be *foreign bodies* in minor wounds. Small pieces of glass or grit lying on a wound can be picked off with tweezers or rinsed off with cold water before treatment. However, you **MUST NOT** try to remove objects that are embedded in the wound; you may cause further tissue damage and bleeding.

1. Control any bleeding by applying firm pressure on either side of the object, and raising the wounded part.
2. Drape a piece of gauze lightly over the wound to minimize the risk of germs entering it, then build up padding around the object until you can bandage without pressing down upon it.
3. Take or send the casualty to hospital.

Bruises

These are caused by internal bleeding that seeps through the tissues to produce the discoloration under the skin. Bruising may develop very slowly and appear hours, even days, after injury. Bruising that develops rapidly and seems to be the main problem will benefit from first aid. Caution, bruises may indicate deeper injury. Seek professional advice.

Minor burns and scalds

These are treated to stop the burning, to relieve pain and swelling and to minimize the risk of infection. If you are in any doubt as to the severity of the injury seek the advice of a doctor.

Do not

- Break blisters or interfere with the injured area; you are likely to introduce an infection.
- Use adhesive dressings or strapping.
- Apply lotions, ointments, creams or fats to the injury.

Note: Chemical burns to the skin and particularly the eyes require immediate and specialist treatment. Expert attention must be obtained *immediately*.

Foreign bodies in the eye

Foreign bodies in the eye can lead to blurred vision with pain or discomfort. They can also lead to redness and watering of the eye. A speck of dust or grit, or a loose eyelash floating on the white of the eye, can generally be removed easily. However, a foreign body that adheres to the

eye, penetrates the eyeball, or rests on the coloured part of the eye should NOT be removed by a first aider. DO NOT touch anything sticking to, or embedded in, the eyeball or the coloured part of the eye. Cover the affected eye with an eye pad, bandage both eyes, then take or send the casualty to hospital.

1.9 Personal protection 1.9.1 Appearance

Clothing

For general workshop purposes a boiler suit is the most practical and safest form of clothing. However, to be completely effective certain precautions must be taken as shown in Fig. 1.10.

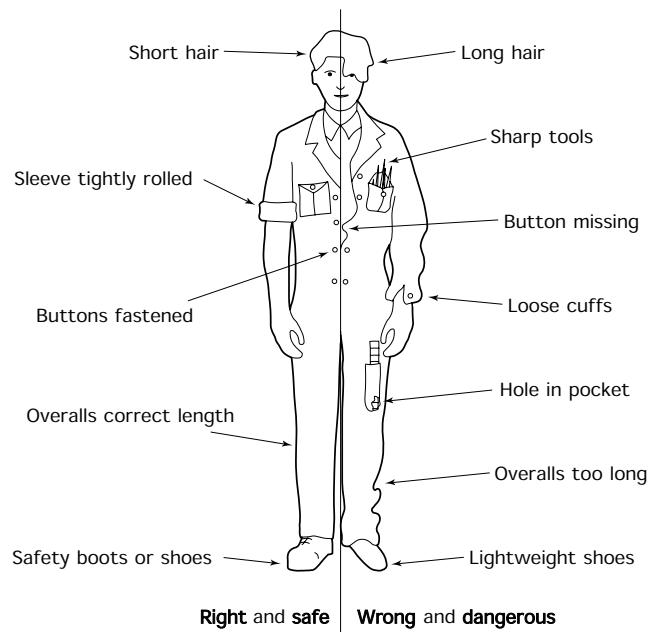


Figure 1.10 *Correct and incorrect dress*

Long hair

- Long hair is liable to be caught in moving machinery such as drilling machines and lathes. This can result in the hair and scalp being torn away which is extremely dangerous and painful. Permanent disfigurement will result and brain damage can also occur.
- Long hair is also a health hazard, as it is almost impossible to keep clean and free from infection in a workshop environment. Either adopt a short and more manageable head style or some sort of head covering

that will keep your hair out of harm's way. Suitable head protection is discussed in Section 1.10.

Sharp tools

Sharp tools protruding from the breast pocket can cause severe wounds to the wrist. Such wounds can result in paralysis of the hand and fingers.

Buttons missing and loose cuffs

Since the overalls cannot be fastened properly, it becomes as dangerous as any other loose clothing and is liable to be caught in moving machinery. Loose cuffs are also liable to be caught up like any other loose clothing. They may also prevent you from snatching your hand away from a dangerous situation.

Hole in pocket

Tools placed in a torn pocket can fall through onto the feet of the wearer. Although this may not seem potentially dangerous, it could cause an accident by distracting your attention at a crucial moment.

Overalls too long

These can cause you to trip and fall, particularly when negotiating stairways.

Lightweight shoes

The possible injuries associated with lightweight and unsuitable shoes are:

- puncture wounds caused by treading on sharp objects;
- crushed toes caused by falling objects;
- damage to your Achilles tendon due to insufficient protection around the heel and ankle. Suitable footwear for workshop use is discussed in Section 1.13.

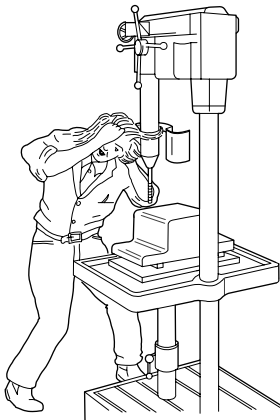


Figure 1.11 *The hazard of long hair*

1.9.2 Head and eye protection

As has already been stated, long hair is a serious hazard in a workshop. If it becomes entangled in a machine, as shown in Fig. 1.11, the operator can be scalped. If you wish to retain a long hairstyle in the interests of fashion, then your hair must be contained in a close fitting cap. This also helps to keep your hair and scalp clean and healthy.

When working on site, or in a heavy engineering erection shop involving the use of overhead cranes, all persons should wear a safety helmet complying with BS 2826. Even small objects such as nuts and bolts can cause serious head injuries when dropped from a height. Figure 1.12(a) shows such a helmet. Safety helmets are made from high impact resistant

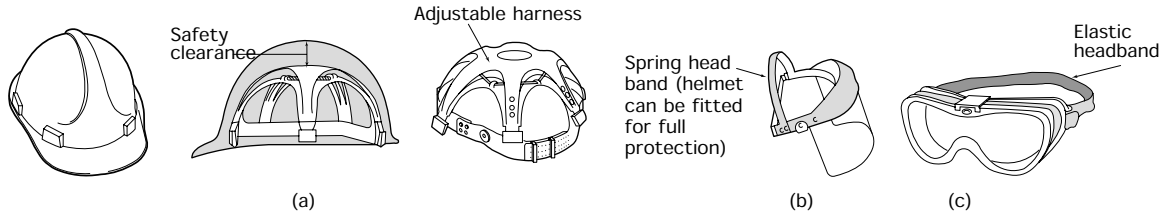


Figure 1.12 *Head and eye protection: (a) a typical fibre-glass safety helmet made to BS 2826; (b) plastic face safety visor for complete protection against chemical and salt-bath splashes; (c) transparent plastic goggles suitable for machining operations*

plastics or from fibre-glass reinforced polyester mouldings. Such helmets can be colour coded for personnel identification and are light and comfortable to wear. Despite their lightweight construction, they have a high resistance to impact and penetration. To eliminate the possibility of electric shock, safety helmets have no metal parts. The harness inside a safety helmet should be adjusted so as to provide ventilation and a fixed safety clearance between the outer shell of the helmet and the wearer's skull. This clearance must be maintained at 32 millimetres. The entire harness is removable for regular cleaning and sterilizing. It is fully adjustable for size, fit and angle to suit the individual wearer's head.

Whilst it is possible to walk about on an artificial leg, nobody has ever seen out of a glass eye. Therefore eye protection is possibly the most important precaution you can take in a workshop. Eye protection is provided by wearing suitable visors as shown in Fig. 1.12(b) or goggles as shown in Fig. 1.12(c).

Eye injuries fall into three main categories:

- Pain and inflammation due to abrasive grit and dust getting between the lid and the eye.
- Damage due to exposure to ultraviolet radiation (arc-welding) and high intensity visible light. Particular care is required when using laser equipment.
- Loss of sight due to the eyeball being pierced or the optic nerve being cut by flying splinters of metal (swarf), or by the blast of a compressed air jet.

Where eye safety is concerned, prevention is better than cure. There may be no cure!

1.9.3 Hand protection

Your hands are in constant use and, because of this, they are constantly at risk handling dirty, oily, greasy, rough, sharp, hot and possibly corrosive and toxic materials. Gloves and 'palms' of a variety of styles and types of materials are available to protect your hands whatever the nature of the work. Some examples are shown in Fig. 1.13. In general terms, plastic gloves are impervious to liquids and should be worn when handling

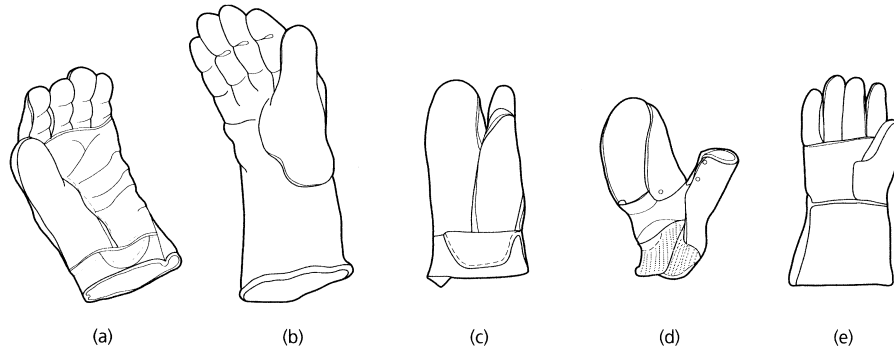


Figure 1.13 Gloves suitable for industrial purposes: (a) leather glove with reinforced palm – ideal for handling steel sheet and sections; (b) gauntlet – available in rubber, neoprene or PVC for handling chemical, corrosive or oily materials; (c) heat resistant leather glove – can be used for handling objects heated up to 360°C; (d) chrome leather hand-pad or ‘palm’ – very useful for handling sheet steel, sheet glass, etc.; (e) industrial gauntlets – usually made of leather because of its heat resistance; gauntlets not only protect the hands but also the wrists and forearms from splashes from molten salts and hot quenching media

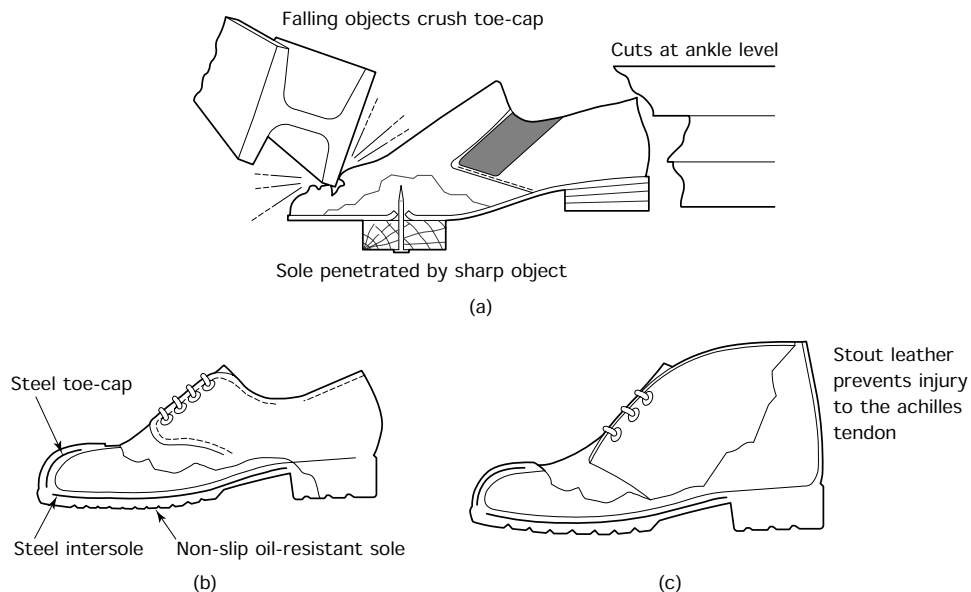


Figure 1.14 Safety footwear: (a) lightweight shoes offer no protection; (b) industrial safety shoe; (c) industrial safety boot

oils, greases and chemicals. However, they are unsuitable and even dangerous for handling hot materials. Leather gloves should be used when handling sharp, rough and hot materials. NEVER handle hot workpieces and materials with plastic gloves. These could melt onto and into your flesh causing serious burns that would be difficult to treat.

Where gloves are inappropriate, as when working precision machines, but your hands still need to be protected from oil and dirt rather than from cuts and abrasions, then you should use a barrier cream. This is a mildly antiseptic cream that you can rub well into your hands before work. It fills the pores of your skin and prevents the entry of oils and dirt that could cause infection. The cream is water-soluble and can be removed by washing your hands with ordinary soap and water at the end of the shift. Removal of the cream carries away the dirt and sources of infection.

DO NOT use solvents to clean your hands except under medical supervision. As well as removing oils, greases, paints and adhesives, solvents also remove the natural protective oils from your skin. This leaves the skin open to infection and can lead to cracking and sores. It can also result in sensitization of the skin and the onset of industrial dermatitis.

1.9.4 Foot protection

The dangers associated with wearing unsuitable shoes in a workshop have already been discussed. The injuries that you can suffer when wearing lightweight, casual shoes are shown in Fig. 1.14. This figure also shows some examples of safety footwear as specified in BS 1870. Such safety footwear is available in a variety of styles and prices. It looks as smart as normal footwear and is almost as comfortable.

1.10 Hazards in the workplace

1.10.1 Health hazards

Noise

Excessive noise can be a dangerous pollutant of the working environment. The effects of noise can result in:

- Fatigue leading to careless accidents.
- Mistaken communications between workers leading to accidents.
- Ear damage leading to deafness.
- Permanent nervous disorders.

Noise is energy and it represents waste since it does not do useful work. Ideally it should be suppressed at source to avoid waste of energy and to improve the working environment. If this is not possible then you should be insulated from the noise by sound absorbent screens and/or ear protectors (earmuffs).

Narcotic (anaesthetic) effects

Exposure to small concentrations of narcotic substances causes headaches, giddiness and drowsiness. Under such conditions you are obviously prone to accidents since your judgement and reactions are adversely affected. A worker who has become disorientated by the inhalation of narcotics is a hazard to himself or herself and a hazard to other workers.

Examples of narcotic substances are to be found amongst the many types of solvent used in industry. Solvents are used in paints, adhesives, polishes and degreasing agents. Careful storage and use is essential and should be carefully supervised by qualified persons. Fume extraction and adequate ventilation of the workplace must be provided when working with these substances. Suitable respirators should be available for use in emergencies.

Irritant effects

Many substances cause irritation to the skin both externally and internally. External irritants can cause industrial dermatitis by coming into contact with your skin. The main irritants met within a workshop are oils (particularly cutting oils and coolants), adhesive, degreasing solvents, and electroplating chemicals. Internal irritants are the more dangerous as they may have long-term and deep-seated effects on the major organs of the body. They may cause inflammation, ulceration, internal bleeding, poisoning and the growth of cancerous tumours. Internal irritants are usually air pollutants in the form of dusts (asbestos fibres), fumes and vapours. As well as being inhaled, they may also be carried into your body on food handled without washing. Even the cutting oils used on machine tools can be dangerous if you allow your overalls to become impregnated with the spray. Change your overalls regularly.

Systemic effects

Toxic substances, also known as *systemics*, affect the fundamental organs and bodily functions. They affect your brain, heart, lungs, kidneys, liver, central nervous system and bone marrow. Their effects cannot be reversed and thus lead to chronic ill-health and, ultimately, early death. These toxic substances may enter the body in various ways.

- Dust and vapour can be breathed in through your nose. Observe the safety codes when working with such substances and wear the respirator provided no matter how inconvenient or uncomfortable.
- Liquids and powders contaminating your hands can be transferred to the digestive system by handling food or cigarettes with dirty hands. Always wash before eating or smoking. Never smoke in a prohibited area. Not only may there be a fire risk, but some vapours change chemically and become highly toxic (poisonous) when inhaled through a cigarette.
- Liquids, powders, dusts and vapours may all enter the body through the skin:
 - (a) directly through the pores;
 - (b) by destroying the outer tough layers of the skin and attacking the sensitive layers underneath;
 - (c) by entering through undressed wounds.

Regular washing, use of a barrier cream, use of suitable protective (plastic or rubber) gloves, and the immediate dressing of cuts (no matter how small) are essential to proper hand care.

1.10.2 Personal hygiene

Personal hygiene is most important. It ensures good health and freedom from industrial diseases. It is also more pleasant for those who work with you if they do not have to put up with unpleasant and unnecessary body odours. There is nothing to be embarrassed about in rubbing a barrier cream into your hands before work, about washing thoroughly with soap and water after work, or about changing your overalls regularly so that they can be cleaned. Personal hygiene can go a long way towards preventing skin diseases, both irritant and infectious. Your employer's safety policy should make recommendations on dress and hygiene and they should provide suitable protective measures. As previously mentioned, dirty and oil soaked overalls are a major source of skin infection. Correct dress not only makes you look smart and feel smart, it helps you to avoid accidents and industrial diseases. This is why overalls should be regularly changed and cleaned. Finally, you must always wash your hands thoroughly before handling and eating any food, and when going to the toilet. If your hands are dirty and oily it is essential to wash them *before* as well as after.

1.10.3 Behaviour in workshops

In an industrial environment reckless, foolish and boisterous behaviour such as pushing, shouting, throwing things, and practical joking by a person or a group of persons cannot be tolerated. Such actions can distract a worker's attention and break his or her concentration. This can lead to scrapped work, serious accidents and even fatalities.

Horseplay observes no safety rules. It has no regard for safety equipment. It can defeat safe working procedures and undo the painstaking work of the safety officer by the sheer foolishness and thoughtlessness of the participants. Accidents resulting from horseplay are caused when:

- A person's concentration is disturbed so that they incorrectly operate their machine or inadvertently come into contact with moving machinery or cutters.
- Someone is pushed against moving machinery or factory transport.
- Someone is pushed against ladders and trestles upon which people are working at heights.
- Someone is pushed against and dislodges heavy, stacked components.
- Electricity, compressed air or dangerous chemicals are involved.

1.10.4 Hazards associated with hand tools

Newcomers to industry often overlook the fact that, as well as machine tools, badly maintained and incorrectly used hand tools can also represent a serious safety hazard.

The time and effort taken to fetch the correct tool from the stores or to service a worn tool is considerably less than the time taken to recover from injury. Figure 1.15 shows some badly maintained and incorrectly used hand tools. Chipping screens, as shown in Fig. 8.10 (see p. 225), should be used when removing metal with a cold chisel to prevent injury from the pieces of metal flying from the cutting edge of the chisel. For this reason, goggles should also be worn and you should never chip towards another worker.

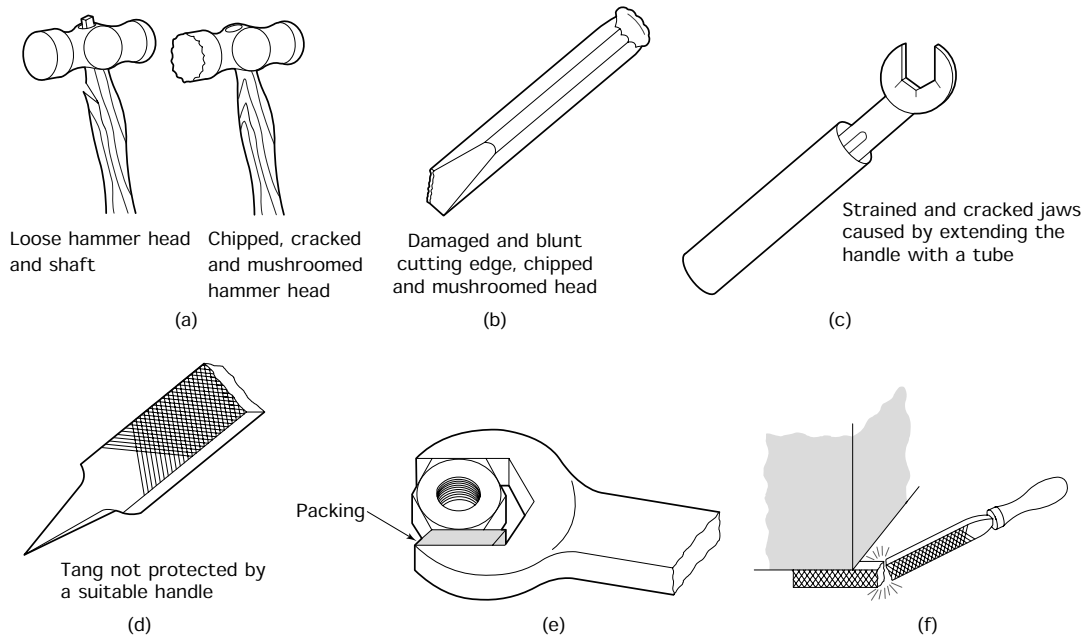


Figure 1.15 Hand tools in a dangerous condition and misused: (a) hammer faults; (b) chisel faults; (c) spanner faults; (d) file faults; (e) do not use oversize spanner and packing – use the correct size of spanner for the nut or bolt head; (f) do not use file as a lever

1.10.5 Hazards associated with machine tools

Metal cutting machines are potentially dangerous.

- Before operating any machinery be sure that you have been fully instructed in how to use it, the dangers associated with it, and that you have been given permission to use it.
- Do not operate a machine unless all the guards and safety devices are in position and are operating correctly.
- Make sure you understand any special rules and regulations applicable to the particular machine you are about to use, even if you have been trained on machines in general.

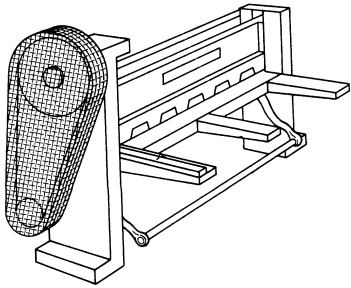


Figure 1.16 *Typical transmission guard for a belt driven machine*

- Never clean or adjust a machine whilst it is in motion. Stop the machine and isolate it from the supply.
- Report any dangerous aspect of the machine you are using, or are about to use, immediately and do not use it until it has been made safe by a suitably qualified and authorized person.
- A machine may have to be stopped in an emergency. Learn how to make an emergency stop without having to pause and think about it and without having to search for the emergency stop switch.

Transmission guards

By law, no machine can be sold or hired out unless all gears, belts, shafts and couplings making up the power transmission system are guarded so that they cannot be touched whilst they are in motion. Figure 1.16 shows a typical transmission guard.

Sometimes guards have to be removed in order to replace, adjust or service the components they are covering. This must be done only by a qualified maintenance mechanic.

Cutter guards

The machine manufacturer does not normally provide cutter guards because of the wide range of work a machine may have to do.

- It is the responsibility of the owner or the hirer of the machine to supply their own cutter guards.
- It is the responsibility of the setter and/or the operator to make sure that the guards are fitted and working correctly before operating the machine, and to use the guards as instructed. It is an offence in law for the operator to remove or tamper with the guards provided.
- If ever you are doubtful about the adequacy of a guard or the safety of a process, consult your instructor or your safety officer without delay.

The simple drilling machine guard shown in Fig. 1.17(a) covers only the chuck and is suitable only for jobbing work when small diameter drills are being used. The drill chuck shown in Fig. 1.17(b) is used for larger

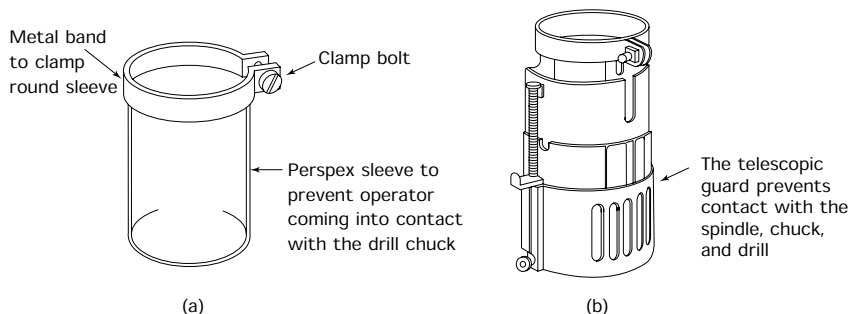


Figure 1.17 *Drill chuck guards: (a) simple; (b) telescopic*

drills and for drills which are mounted directly into the drilling machine spindle. It covers the whole length of the drill and telescopes up as the drill penetrates into the workpiece.

Guards for use with milling machines, centre lathes, and grinding machines will be dealt with in the later chapters specifically relating to the use of such machines and their special hazards.

1.11 Manual lifting

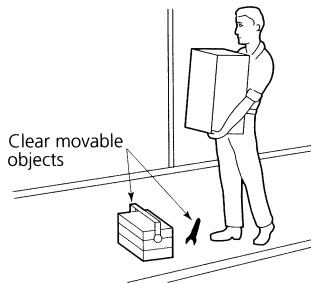


Figure 1.18 *Obstructions to safe movement must be removed*

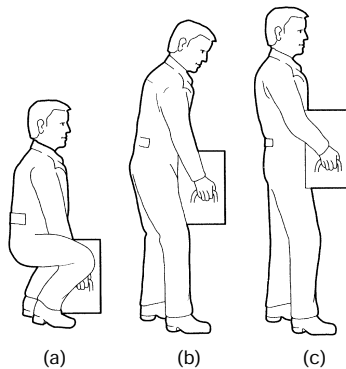


Figure 1.19 *Correct manual lifting: (a) keep back straight and near vertical; (b) keep your spine straight; (c) straighten your legs to raise load*

1.11.1 Individual lifting

In the engineering industry it is often necessary to lift fairly heavy loads. As a general rule, loads lifted manually should not exceed 20 kg. Mechanical lifting equipment should be used for loads in excess of 20 kg. However, even lifting loads less than 20 kg can cause strain and lifting loads incorrectly is one of the major causes of back trouble. If the load is obviously too heavy or bulky for one person to handle, you should ask for assistance. Even a light load can be dangerous if it obscures your vision as shown in Fig. 1.18. All movable objects that form hazardous obstructions should be moved to a safe place before movement of the load commences.

As has already been stated, it is important to use the correct lifting technique. This is because the human spine is not an efficient lifting device. If it is subjected to heavy strain, or incorrect methods of lifting, the lumbar discs may be damaged causing considerable pain. This is often referred to as a 'slipped disc' and the damage (and pain) can be permanent.

The correct way to lift a load manually is shown in Fig. 1.19. You should start the lift in a balanced squatting position with your legs at hip width apart and one foot slightly ahead of the other. The load to be lifted should be held close to your body. Make sure that you have a safe and secure grip on the load. Before taking the weight of the load, your back should be straightened and as near to the vertical as possible. Keep your head up and your chin drawn in, this helps to keep your spine straight and rigid as shown in Fig. 1.19(a). To raise the load, first straighten your legs. This ensures that the load is being raised by your powerful thigh muscles and bones, as shown in Fig. 1.19(b), and not by your back. To complete the lift, raise the upper part of your body to a vertical position as shown in Fig. 1.19(c).

To carry the load, keep your body upright and hold the load close to your body. If the load has jagged edges wear protective gloves and if hazardous liquids are being handled wear the appropriate protective clothing as shown in Fig. 1.20.

1.11.2 Manual lifting (team)

When a lifting party is formed in order to move a particularly large or heavy load the team leader is solely responsible for the safe completion of the task. The team leader should not take part in the actual lifting but should ensure that:

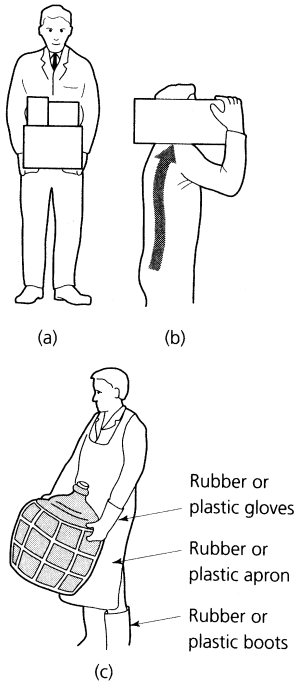


Figure 1.20 *Correct carrying:* (a) keep body upright and load close to body; (b) let your bone structure support the load; (c) wear appropriate clothing

- Everyone understands what the job involves and the method chosen for its completion.
- The area is clear of obstructions and that the floor is safe and will provide a good foothold.
- The members of the lifting party are of similar height and physique, and that they are wearing any necessary protective clothing. Each person should be positioned so that the weight is evenly distributed.
- The team leader takes up a position which gives the best all round view of the area and will permit the development of any hazardous situation to be seen so that the appropriate action can be taken in time to prevent an accident.
- Any equipment moved in order to carry out the operation is put back in its original position when the task has been completed. This sequence of events is shown in Fig. 1.21.

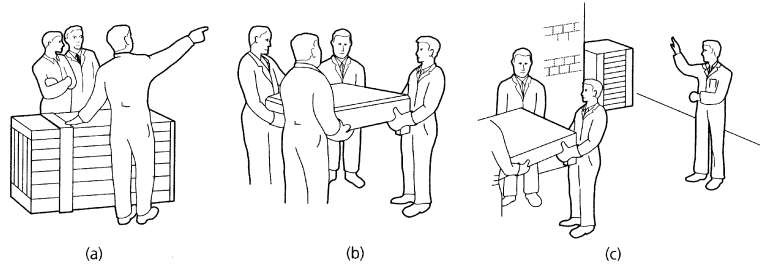


Figure 1.21 *Team lifting*

Loads that are too heavy to be lifted or carried can still be moved manually by using a crowbar and rollers as shown in Fig. 1.22. The rollers should be made from thick walled tubes so that there is no danger of trapping your fingers if the load should move whilst positioning the rollers. Turning a corner is achieved by placing the leading roller at an angle. As the load clears the rearmost roller, this roller is moved to the front, so that the load is always resting on two rollers, whilst the third roller is being positioned.

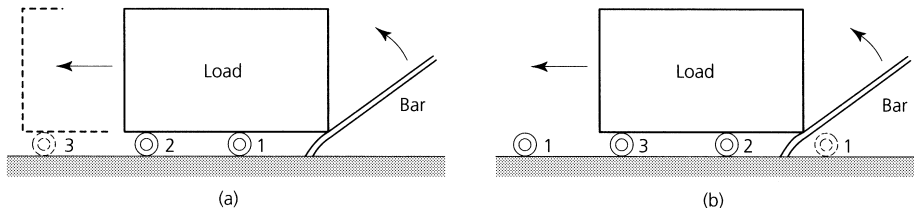


Figure 1.22 *Use of rollers:* (a) load is rolled forward on rollers 1 and 2 until it is on rollers 2 and 3, roller 1 is moved to the front ready for next move

1.12 Mechanical lifting equipment

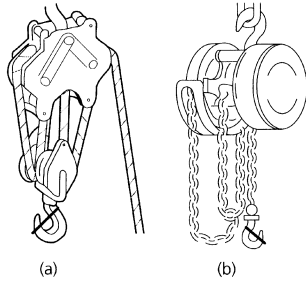


Figure 1.23 Manual lifting equipment: (a) rope pulley blocks (snatch blocks); (b) chain blocks (geared)

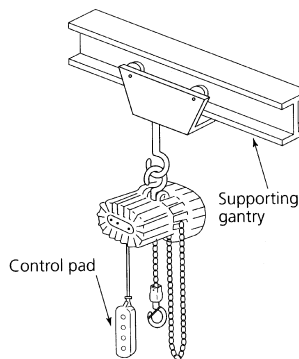


Figure 1.24 Powered lifting equipment

1.13 Use of lifting equipment

Mechanical lifting equipment can be classified according to the motive power used to operate it.

1.12.1 Manual (muscle power)

Examples of this type of equipment are shown in Fig. 1.23. Rope pulley blocks (snatch blocks) are light and easily mounted. However, the tail rope has to be tied off to prevent the load falling when the effort is removed. Some rope blocks have an automatic brake which is released by giving the tail rope a sharp tug before lowering the load. They are suitable for loads up to 250 kg. Chain pulley blocks are portable and are used for heavier loads from 250 kg to 1 tonne. They also have the advantage that they do not run back (overhaul) when the effort raising the load is removed.

1.12.2 Powered

An example of an electrically powered hoist is shown in Fig. 1.24. Powered lifting equipment is faster and can raise greater loads than manually operated chain blocks.

1.12.3 Safety

Only fully competent persons (i.e. trained and authorized) are permitted to operate mechanical lifting equipment. Trainees can use such equipment only under the close supervision of a qualified and authorized instructor.

1.13.1 Lifting a load

Before lifting a load using a mechanical lifting device you should:

- Warn everyone near the load and anyone approaching the load to keep clear.
- Check that all slings and ropes are safely and securely attached both to the load and to the hook.
- Take up the slack in the chain, sling or rope gently.
- Raise the load slowly and steadily so that it is just off the ground.
- Check that the load is stable and that the sling has not become accidentally caught on a part of the load incapable of sustaining the lifting force.
- Stand well back from the load and lift steadily.

1.13.2 Lowering a load

Before lowering a load:

- Check that the ground is clear of obstacles and is capable of supporting the load.
- Place timbers under the load as shown in Fig. 1.25(a) so that the sling will not be trapped and damaged. This will also facilitate the removal of the sling.
- Lower the load until it is close to the ground and then gently ease it onto the timbers until the strain is gradually taken off the lifting equipment. It may be necessary to manually guide the load into place as shown in Fig. 1.25(b), in which case safety shoes and protective gloves should be worn.
- Never work under a suspended load. Always lower the load onto suitable supports as shown in Fig. 1.25(c).

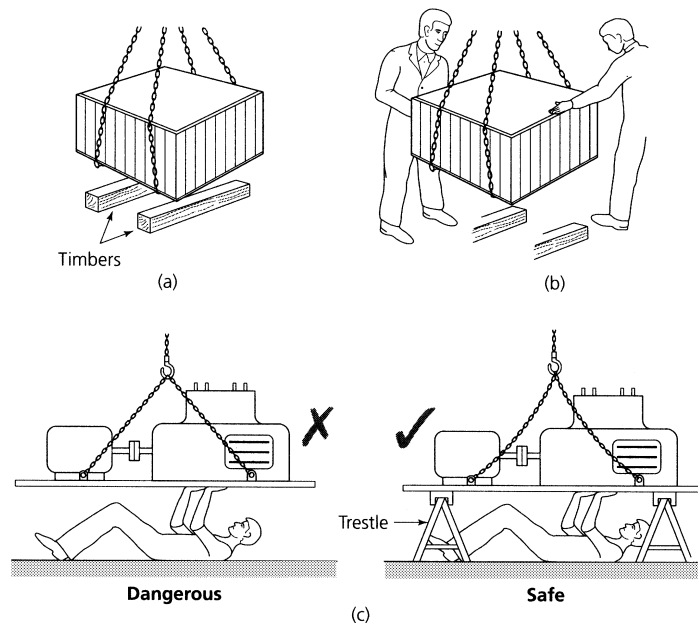


Figure 1.25 Care when lowering a load: (a) lower onto timbers; (b) guide by hand; (c) never work under a suspended load

1.14 Accessories for lifting equipment

Hooks

These are made from forged steel and are carefully proportioned so that the load will not slip from them whilst being lifted. The hooks of lifting

gear are frequently painted bright yellow to attract attention and to prevent people walking into them.

Slings

These are used to attach the load to the hook of the lifting equipment. There are four types in common use. They must all be marked with tags stating their safe working load (SWL).

- Chain slings (Fig. 1.26(a)) – as well as general lifting, only this type of sling is suitable for lifting loads having sharp edges or for lifting hot materials.
- Wire rope slings (Fig. 1.26(b)) – these are widely used for general lifting. They should not be used for loads with sharp edges or for hot loads; nor should they be allowed to become rusty. Further, they should not be bent round a diameter of less than 20 times the diameter of the wire rope itself.
- Fibre rope slings (Fig. 1.26(c)) – fibre rope slings may have eyes spliced into them or, more usually, they are endless as shown. They are used for general lifting, and are particularly useful where machined surfaces and paintwork have to be protected from damage.
- Belt or strap slings – because of their breadth they do not tend to bite into the work and cause damage to the surface finish of the work. Rope and belt slings themselves must be protected from being cut or frayed by sharp edges as shown in Fig. 1.26(d). This packing also prevents the fibres of the slings from being damaged by being bent too sharply around the corners of the object being lifted.

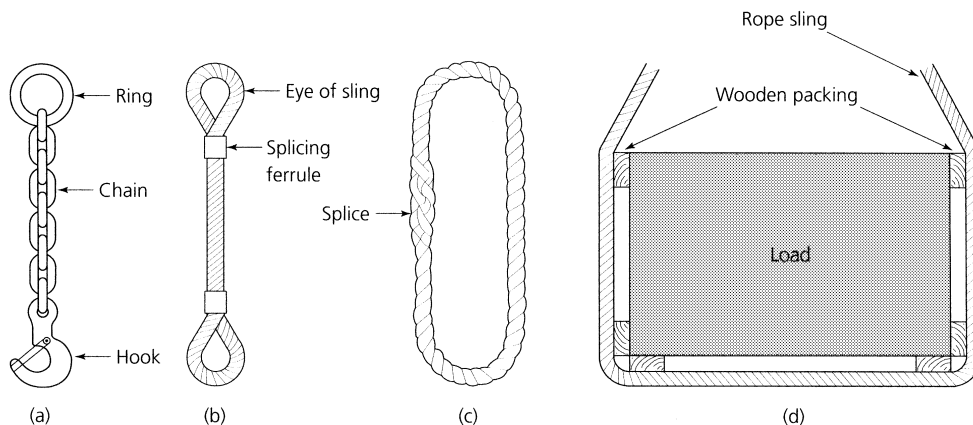


Figure 1.26 *Types and care of slings*

Care of slings

Wire rope and fibre rope slings must not be shortened by knotting since this damages the fibres causing them to fracture. Chain slings must not be shortened by bolting the links together.

Condition of slings

All slings must be checked before use for cuts, wear, abrasion, fraying and corrosion. Damaged slings must never be used and the fault must be reported.

Length of slings

Rope or chain slings must be long enough to carry the load safely and with each leg as nearly vertical as possible as shown in Fig. 1.27(a). The load on a sling increases rapidly as the angle between the legs of the sling becomes greater. This is shown in Fig. 1.27(b).

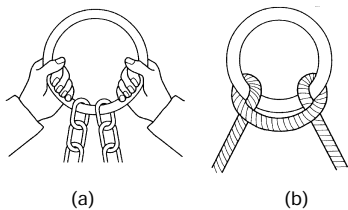
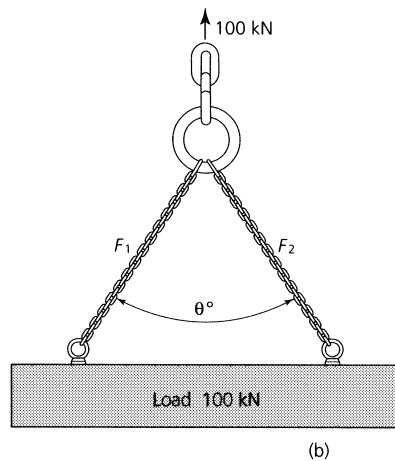
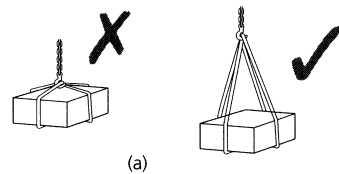


Figure 1.28 Use of rings:
(a) with 2 leg chain sling;
(b) with a rope sling

Figure 1.27 Length of slings: (a) correct length; (b) incorrect length

Rings

These are used for ease of attachment of the sling to the crane hook. They also prevent the sling being sharply bent over the hook. Figure 1.28(a)

shows a chain sling fitted with a suitable ring at one end. Figure 1.28(b) shows how a ring is used in conduction with a rope sling.

Eyebolts and shackles

Forged steel eyebolts to BS 4278 are frequently provided for lifting equipment and assemblies such as electric motors, gearboxes, and small machine tools. An example of the correct use of an eyebolt is shown in Fig. 1.29(a), whilst Fig. 1.29(b) shows how eyebolts must never be used. Forged steel shackles are used to connect lifting accessories together. In the example shown in Fig. 1.29(c), the eye of a wire rope sling is connected to an eyebolt using a shackle.

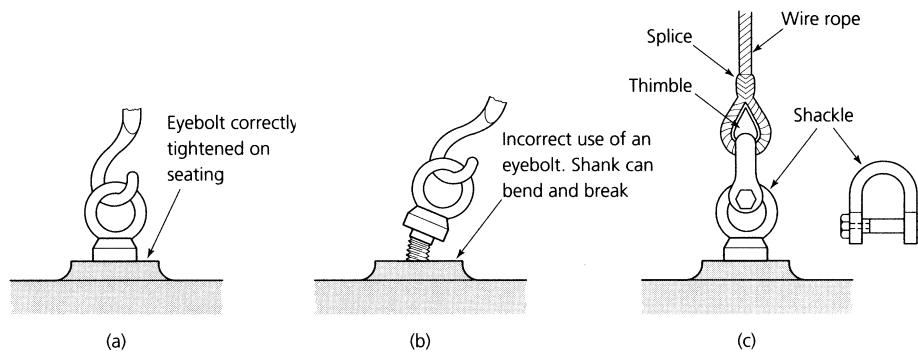


Figure 1.29 Use of eyebolts: (a) correct use; (b) incorrect use; (c) a shackle connects the eye of the sling to an eye bolt

1.15 Useful knots for fibre ropes

It is useful to know about the knots that can be tied in fibre ropes when moving and securing loads. Knots must never be tied in wire ropes as they are not sufficiently flexible and permanent damage will be caused. Some widely used knots are as follows.

Reef knot

This is used for joining ropes of equal thickness (Fig. 1.30(a)).

Clove hitch

This is used for attaching a rope to a pole or bar (Fig. 1.30(b)).

Single loop

This is used to prevent fibre ropes from slipping off crane hooks (Fig. 1.30(c)).

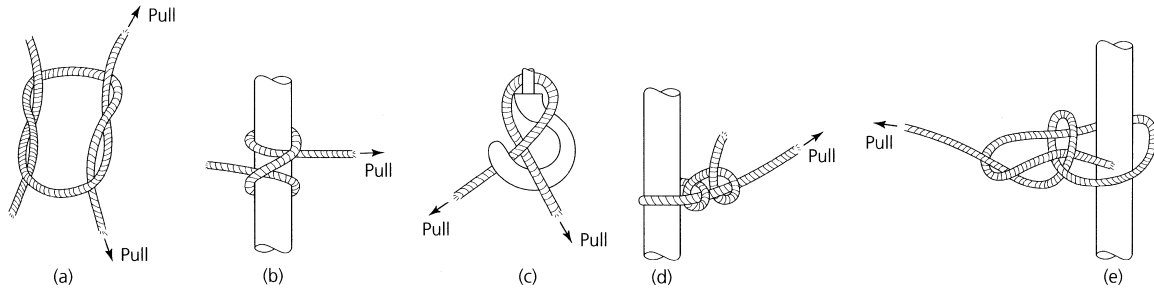


Figure 1.30 Useful knots for fibre ropes: (a) reef knot; (b) clove hitch; (c) single loop; (d) two half hitches; (e) bowline

Half hitches

Two half hitches can be used to secure a rope to a solid pole or for securing a rope to a sling (Fig. 1.30(d)).

Bowline

This is used to form a loop which will not tighten under load (Fig. 1.30(e)).

1.16 Transporting loads (trucks)

Various types of truck are used for transporting loads around workshops and factory sites. Only manually propelled trucks will be considered. Power-driven trucks are beyond the scope of this book. The simplest sort of truck is the hand truck (sack truck) shown in Fig. 1.31(a). It uses the principle of levers to raise the load ready for wheeling away. Quite heavy loads can be moved quite easily with this type of truck.

Platform or flat trucks are used with various wheel arrangements so that they can be steered. The type shown in Fig. 1.31(b) requires the load to be placed over the wheels so that the truck is balanced for ease of movement. The type shown in Fig. 1.31(c) has a wheel at each end and the load does not have to be so carefully balanced. Only one end wheel is in contact with the ground at any one time. Also the end wheels can slide. This facilitates steering. A heavier duty 'turntable' type truck is shown in Fig. 1.31(d). This has four wheels in the conventional position and the front wheels can be turned so that the truck can be steered.

Whichever type of truck you use there are two safety points you should observe.

- Stack the load on the trolley so that you can see where you are going in order to avoid a collision, particularly if people are working on ladders or steps along the route you are taking.
- Balance the load so that it will not topple off the truck or overturn the truck when you are turning a corner.

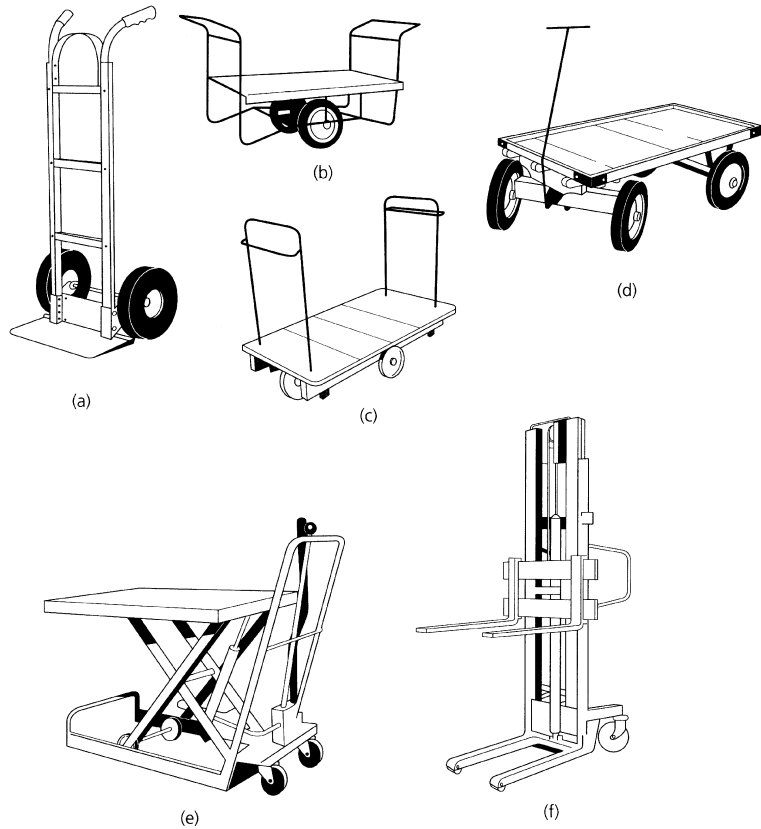


Figure 1.31 Types of trucks: (a) sack truck; (b) two-wheeled platform truck (balanced); (c) sliding wheel platform truck; (d) heavy duty, turntable platform type truck; (e) elevating table truck; (f) stacking truck

1.17 Inspection (lifting equipment)

It is a legal requirement under the Health and Safety at Work, etc. Act that all lifting equipment is regularly inspected by qualified engineers specializing in such work and that the results of such inspections are recorded in the register provided. If an inspector condemns any item of equipment it must be taken out of service immediately and either rectified or destroyed. If rectified, it must be reinspected and approved by a qualified inspector before being taken back into service. The inspector will, on each visit, also confirm the safe working load (SWL) markings for each piece of equipment. No new item of lifting equipment must be taken into service until it has been inspected and certificated.

Exercises 1.1 *Health and Safety at Work, etc. Act and other important industrial legislation*

- (a) (i) What do the initials HSE stand for?
(ii) What is a Prohibition Notice?
(iii) What is an Improvement Notice?
(iv) Who issues the notices in (ii) and (iii) above?
- (b) As an employee you also have duties under the Act. Copy out and complete Table 1.1 by writing brief comments regarding your duties in the following circumstances.

TABLE 1.1 *Exercise 1.1(b)*

<i>Circumstances</i>	<i>Duties</i>
You are uncertain how to operate a machine needed to complete your task	
You need to carry some sheet metal with very sharp edges	
You are working on site and you have mislaid your safety helmet	
You find that the belt guard has been removed from a machine you have been told to use	
You have spilt hydraulic oil on the floor whilst servicing a machine	
The earth wire has come disconnected from a portable power tool you are using	
Your supervisor has told you to clear up the rubbish left by another worker	
You find someone smoking in a prohibited area	

TABLE 1.2 *Exercise 1.1(c)*

<i>Situation</i>	<i>Appropriate industrial regulations</i>
Use of grinding machines and abrasive wheels	
Eye protection	
Electrical control equipment, use and maintenance	
Use of substances that can be harmful to health (solvents, etc.)	
Safe use of power presses	
Protection against high noise levels	
Safe use of milling machines	
Use of protective clothing	

- (c) Copy out and complete Table 1.2 by adding the name of the most appropriate industrial regulation(s) for each of the situations given.
- (d) Copy out and complete Fig. 1.32 by stating:
- (i) the category of sign (e.g. warning sign, mandatory sign, etc.);
 - (ii) the meaning of sign;
 - (iii) where it would be used.








Sign	Meaning	Category	Where used
			
			
			
			
			
			
			

Figure 1.32 Exercise 1.1(d)

1.2 Electrical hazards

- (a) Explain why portable electrical equipment should be:
- (i) earthed unless it is 'double insulated';
 - (ii) operated from a low-voltage supply;

- (iii) protected by an earth leakage isolator incorporating a residual current detector.
- (b) When you are issued with portable electrical equipment from the stores you should make a number of visual checks before accepting and using the equipment. Describe these checks.
- (c) If the checks you made in (b) above showed the equipment to be faulty, what action should you take?
- (d) In the event of a workmate receiving a severe electric shock that renders him/her unconscious, what emergency action should you take.

1.3 *Fire hazards*

- (a) List **THREE** main causes of fire on industrial premises.
- (b) If you detect a fire in a storeroom at work, what action should you take?
- (c) Figure 1.33 shows some various types of fire extinguisher.
 - (i) State the types of fire upon which each extinguisher should be used and any precautions that should be taken.
 - (ii) State the colour coding that identifies each type of fire extinguisher.

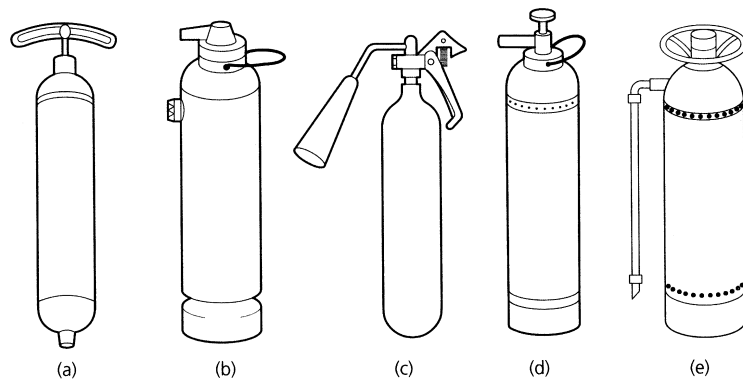


Figure 1.33 *Exercise 1.3(c)*

1.4 *Accidents*

- (a) Why should all cuts, bruises and burns be treated by a qualified first aider, and what risks does a well-meaning but unqualified person run in attempting first aid?
- (b) Apart from rendering first aid what other action must be taken in the event of an accident?
- (c) State how you would identify a first aid post.
- (d) What action should you take if you come across someone who has received a serious accident (broken bones, severe bleeding, partial or complete loss of consciousness, etc.)?
- (e) Briefly describe the accident reporting procedures for your place of work or training workshop.

1.5 Working environment

- (a) Copy out and complete Table 1.3 by stating the type of working environment in which you would need to use the following items of safety clothing and equipment listed in the table.

TABLE 1.3 Exercise 1.5(a)

<i>Clothing/equipment</i>	<i>Situation/environment</i>
Ear protectors	
Overalls	
PVC apron	
Leather apron	
Leather gloves	
PVC/rubber gloves	
Safety helmet	
Clear goggles	
Visor	
Barrier cream	
Safety boots	
Goggles with filter lenses	

- (b) With the aid of a sketch explain what is meant by:
- (i) a transmission guard;
 - (ii) a cutter guard.
- (c) For each of the examples listed below, sketch an appropriate item of safety equipment and state how it works.
- (i) A travelling chip guard on a lathe.
 - (ii) A milling-cutter guard where the machine is being operated by a skilled operator.
 - (iii) A drill chuck guard.
 - (iv) A chipping screen.
 - (v) An interlocked transmission guard.

1.6 Lifting and carrying

- (a) State the maximum recommended weight that may be lifted without the aid of mechanical lifting equipment.
- (b) With the aid of sketches show the correct and incorrect way to lift a load.
- (c) What precautions should be taken when carrying loads?
- (d) What precautions should be taken when moving a heavy load with a lifting team?
- (e) Lifting equipment should be marked with its SWL.
- (i) State what these initials stand for.
 - (ii) State how often lifting equipment needs to be tested and examined.
 - (iii) State what records need to be kept.

2 Establishing effective working relationships

When you have read this chapter you should understand how to:

- Create and maintain effective working relationships with supervisory staff.
- Create and maintain working relationships with other people, members of the same working groups and other employees in the same organization.

2.1 Basic relationships Even the smallest businesses have to communicate with, and relate to, a surprising number of people either through necessity or because it is the law. This is shown in Fig. 2.1.

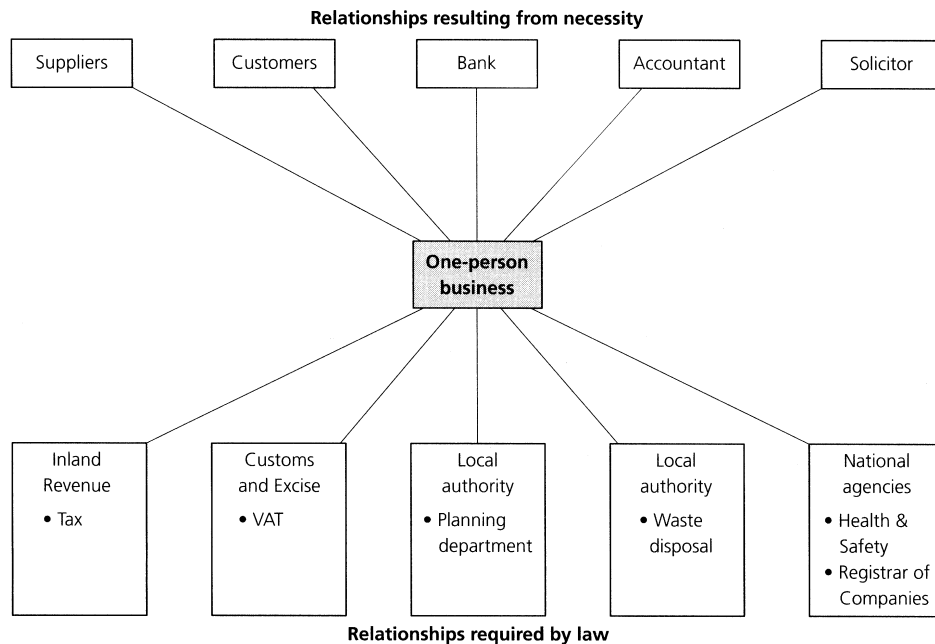


Figure 2.1 *Structure of relationships*

In the first group (*necessity*) are your suppliers of raw materials and tools and equipment used in production. Also you have to deal with the

customers who buy your products and the transport organizations who deliver your products to your customers. You also need a bank and since, from time to time, you may need an overdraft, it's as well to maintain good relationships with your bank manager. There is no law that says you have to have suppliers, customers and bankers but you would not get far in business without them.

There is no law that says you need a solicitor or an accountant. However, you will require a solicitor to draw up all the documents required when setting up the business and when problems arise with customers, suppliers and the local authority (e.g. noise complaints from the neighbours). You will require an accountant to audit your accounts, advise on financial matters, sort out your tax returns, make sure that you avoid overpayment of tax, and to deal with the Customs and Excise officials over your VAT payments and returns. Therefore it is a *necessity* that you make every effort to maintain *good working relationships* with them.

In the second group (*law*) you have to communicate with such persons as local authority inspectors (planning officers, etc.), tax inspectors, VAT inspectors, and health and safety inspectors. These people have the power of the legal system behind them so it pays to maintain *good working relationships* with them.

In our working lives we have constantly to relate to and communicate with other people. For example, we have to exchange technical data, implement management decisions and safety policy, and relate to other people within the company and also to people such as customers and buyers who work outside the company. In this section we are concerned mainly with the people with whom you will work on a daily basis; not only your workmates but also your immediate supervisors and managers.

Having made the point that no one can work in isolation even if they are the sole proprietor of a one person firm, let's consider the situation if you are an employer or an employee in a small, medium or large company. Like it or not, you are going to be one of a team. Like it or not, you are going to have to communicate, participate and co-operate. You are going to have to maintain *good working relationships*. When dealing with other people, you can adopt one of two possible attitudes. You can either *confront* them or you can *co-operate* with them.

2.1.1 Confrontation

Confrontation is how the aggressive, bullying person works. A confrontational person demands and threatens to get his or her own way. It may work in the short term as long as the aggressor has the whip hand. However, such aggressive bullies never win the respect of the people with whom they work. They can never rely upon the loyalty of the people they have continually confronted when a favour is required. It would be no good expecting 'goodwill' co-operation when an extra effort is required to complete an urgent order on time.

2.1.2 Co-operation

This is how sensible, civilized people work. They collaborate and help each other. In this way they gain respect for each other. This results in

the development of efficient working relationships and efficient working practices. In an emergency everyone can be relied upon to make a maximum effort and to help each other.

2.1.3 'Reading' people

As you become more experienced in dealing with people, you will realize that the most important skill is learning to 'read' their moods. You must be able to realize with whom you can have a joke and with whom you can't. You need to know who only wants a 'yes or no' answer and who prefers to discuss a problem. You need to know when to be friendly and when to be aloof, when to offer a word of sympathy or advice, and when to leave somebody alone to get over a bad mood.

2.2 Relationships with managers, supervisors and instructors

You are *employed* by the firm for whom you work, but you are *responsible* to your immediate superior. Depending on the structure of the company your immediate superior may be an instructor, a charge-hand, a foreman or forewoman, a supervisor, a manager or, in a very small firm, the 'Boss' himself.

Figure 2.2 shows the structure of a training department for a large company. The structure will vary from firm to firm but, whatever the size of the company and the structure of its training facilities, it is always

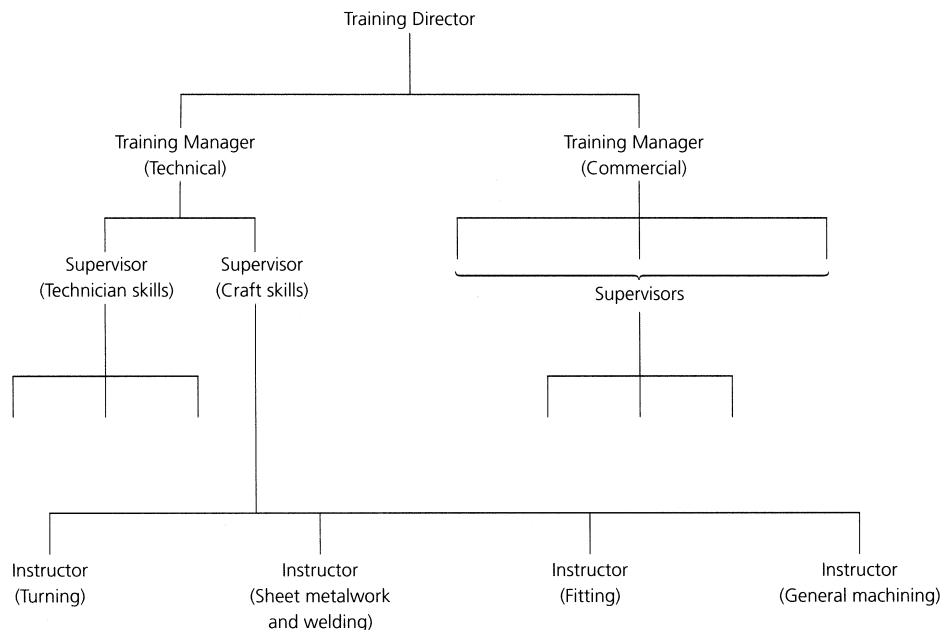


Figure 2.2 *Training personnel structure*

a good idea to find out what the structure is. You need to know who influences your training package, who trains you and who is responsible for your welfare, discipline and assessment. The change from the school environment to the adult working environment often poses unforeseen problems. It is essential to know who you should turn to when you need advice.

First and foremost, it is most important that you get on well with your instructor, your supervisor and your training manager. Each of them will require a different approach. This is not only because they are different people, but also because they have a different status and a different level of importance in the company. Let's now see how you can make a 'good impression' on these people and establish good working relationships with them. For example:

- Develop a habit of good time-keeping and regular attendance, even under difficult conditions.
- Be neat and tidy in your appearance.
- Keep your work area neat and tidy and your tools and instruments in good condition.
- Keep your paperwork up to date, fill it in neatly and keep it clean in a plastic folder.
- File your paperwork systematically so that you can produce it for your instructor or your training manager on demand. 'Attention to detail' always makes a good impression.
- Be reliable so that people quickly find that they can depend upon you.
- Be conscientious: always try your hardest and do your best.
- Reasonable requests for information should be dealt with promptly, accurately and in a co-operative manner providing they do not unduly interfere with or interrupt your work.
- If responding to any request is going to take time and interrupt your work, or if it requires you to leave your working area, always seek permission from your supervisor or instructor before carrying out the request. Always turn your machine off before leaving it.
- If you are in the middle of an intricate piece of work that requires your full concentration, don't just down tools, but ask politely if you may complete your task before responding to the request.
- No matter how tired you are or how inconvenient, trivial and unnecessary the request may seem to you, always try to be cheerful, helpful and efficient. NEVER answer in a surly, unco-operative, couldn't care less, any old time will do, manner.

Your relationships with other people, particularly your instructor, must be a dialogue of instruction and advice. If you are in doubt you must always discuss your problem with your instructor until you are certain that you fully understand what you have to do. Your instructor is also there to help you with any personal problems you may have or problems with other

people with whom you have to work. He or she wants to get to know you as a person so that they can get the best from you and help you to make a success of your training.

Should your instructor be talking to another trainee or his supervisor or manager, don't just barge in, either get on with another job and come back later or wait to one side, respectfully, until it is your turn. Be patient, on no account should you try and start work on a job or on a machine without instruction just because your instructor is busy and you are tired of waiting for him or her.

2.3 Attitude and behaviour

2.3.1 Attitude

When you enter the world of industry you are a very new, very unimportant and very expendable member of the workforce. You know little or nothing about the skills of engineering so, if you are going to complete your training successfully and become a useful member of the company and of society as a whole, you've got a great deal to learn.

Your training is a major investment for your employer. Therefore employers need to train and employ reliable people who they can rely upon and who will give them a reasonable return for their investment in time and money. Those who demonstrate good attitudes are the most likely to succeed. It is no good being the most skilful apprentice or trainee if you are also the most temperamental. Whilst high levels of skill are important, so is consistency, reliability, loyalty and the ability to work in a team.

The greatest incentive to learning a trade is the earning power it gives you. To learn a trade you need the skilled help and advice of a lot of people. You must respect their skill and experience if you are to get their help and advice in return.

Apart from the advice already given, here are some further suggestions.

- Dress in the way recommended by your company. Many firms provide smart overalls bearing the company logo. Do not turn up to work looking scruffy. For example, a long hairstyle not only gives a bad impression it can also be very dangerous (see 1.9).
- For hygiene reasons change into clean overalls daily if possible. Dirty, oily overalls can cause serious hygiene and health problems. A tidy person has a tidy and receptive mind.
- Listen carefully to the instructions your instructor gives to you, particularly safety instructions. Never operate a machine or carry out a process if you are in doubt; always check again with your instructor.
- Keep a log of the operations you are taught and the work you do because your practical skill training has to be assessed in order for you to obtain your certification. Since you may have to present your logbook at a future job interview it is worthwhile spending some time on it. Keep it neat and clean in a plastic folder.

- Show consistency, commitment and dedication in carrying out the tasks set you. Work to as high a standard as you can and always be trying to improve your standards. Have pride in your work, you never know who is going to look at it. This applies not only to the production of components and assemblies but equally to organizational tasks.

2.3.2 Behaviour

In an industrial environment horseplay and fooling around infers reckless and boisterous behaviour such as pushing, shouting, throwing things and practical joking by a person or a group of persons. Engineering equipment is potentially very dangerous and this sort of behaviour cannot be tolerated in an industrial environment.

As well as the negative attitude to behaviour just described, there are positive attitudes to be taken as well. For example, keep your workstation clean and tidy, also clean up any spillages immediately and keep the area where you are working swept clear of swarf and other rubbish. Use the waste bins provided.

2.4 Implementing company policy

Company policy may be dictated by the 'Boss' in a small company or it may be set by the board of directors in a large company. These people are not free agents and they have to abide by national and international laws and guidelines in setting out a strategy for the company. They have to consider the demands of the shareholders, and they are also responsible for the success, profitability and growth of the company upon which the job security and rewards of all who work for the company depend. For these reasons company policy should be understood and obeyed. In successful companies this is not an entirely autocratic process and there are various committee structures through which ideas from the shop floor can be fed back up the command chain to the senior management. This is particularly true for safety issues.

2.4.1 Health, safety and personal hygiene

Health, safety and personal hygiene were dealt with in detail in Chapter 1. These issues were given a whole chapter to themselves because they are so important. All engineering and manufacturing companies are legally bound by the provisions of the Health and Safety at Work, etc. Act of 1974, and other related legislation. The safety policy of your company must take on board all the requirements of such legislation.

Instructors and training managers have a vital part to play in fulfilling their obligations under such safety legislation and in anticipating and averting dangerous situations. Equally, by their manner in handling equipment and tools they must set a good example to their trainees and encourage attitudes of care and confidence.

Personal hygiene is most important. There is nothing to be embarrassed about in rubbing a barrier cream into your hands before work. There is nothing to be embarrassed about in washing thoroughly with soap and hot

water after work, or about changing your overalls regularly so that they can be cleaned, or about wearing protective plastic or rubber gloves to protect your hands from chemicals and solvents. Personal hygiene can go a long way towards preventing skin diseases, both irritant and infectious.

2.4.2 Communications

No company can exist without lines of communications both internal and external. Without internal lines of communication the company policy could not be communicated to the workforce, nor would the senior management know if their policies were being carried out. Figure 2.3 shows a typical management structure for a company.

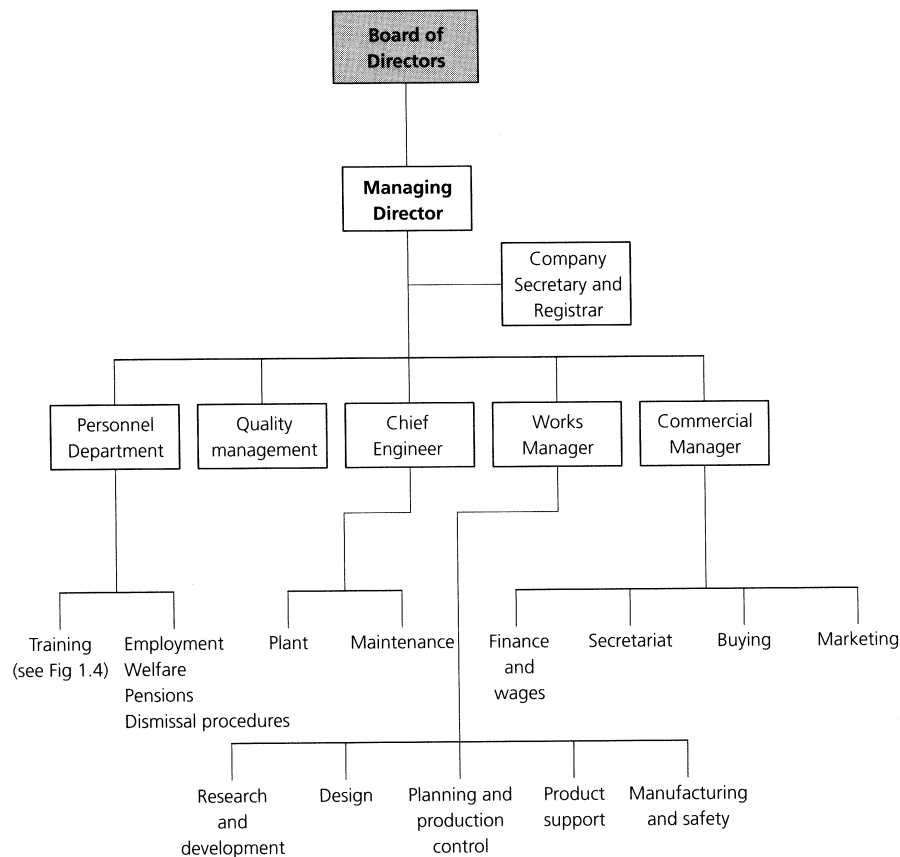


Figure 2.3 *Management structure*

This structure not only represents the lines of communication by which the senior management can ensure that decisions are passed down the line, it represents a route by which messages and requests are sent back up to the various levels of management. These channels of communication are

part of company policy and, to bypass them, can lead to confusion and friction between the parties concerned.

Wherever possible, always use the standard forms provided when communicating within your company. This will result in your requests being treated seriously. Such forms may range from the stores requisition forms that you fill in daily, to job application forms and internal promotion application forms. Always follow laid down procedures.

External lines of communication are equally important so that the company can communicate with its customers and suppliers. Market research, public relations and advertising are essential to the success of a company and depend upon the use of suitable means of communication. This is why many companies employ firms of consultants specializing in these fields.

Verbal communications can take place via the telephone on a 'one to one' basis or via meetings when information has to be given to a number of people at the same time. The advantage of verbal communication is that an instant response can be received and a discussion can take place. The disadvantage of verbal communication is its lack of integrity. Messages can be forgotten, they can be repeated inaccurately, or they can be misinterpreted. All verbal messages should be backed up by written confirmation.

For accuracy, send a letter, fax, e-mail or a written memorandum in the first place. All firms of any standing use pro-forma documents such as letter paper with printed headings, official memorandum forms, official order forms, official invoice forms and despatch notes, and many other pre-printed documents. This ensures consistency of communication policy and saves time since only the details and an approved signature need to be added.

Nowadays electronics has speeded up internal and external communications and many firms are heading towards so-called 'paperless offices'. Increasingly, communications will be sent digitally. Files saved on disk instead of on paper remove the need for bulky filing cabinets.

2.4.3 Recording and filing

The need for keeping a training log and the need for using the standard forms supplied by your company has already been introduced. Nowadays most companies need their quality control system to be BS EN 9000 approved. This is because most of their customers will be so approved and will only be able to purchase their supplies from companies who are similarly approved. To trace the progress of all goods from supplier to customer records must be kept and filed. The principles of quality control will be outlined in Chapter 3.

It is no use completing forms and keeping records unless they are properly filed. The success of any filing system depends upon the ease with which any documents can be retrieved on demand. If any file is removed from a filing system, a card must be inserted in its place stating who has borrowed the file and when. The file must be returned as soon as possible so that it does not become lost.

2.5 Creating and maintaining effective working relationships with other people

As has been stated previously, you cannot work in isolation. Sooner or later you have to relate to other people. In fact, most working situations rely upon teamwork.

2.5.1 Positive attitudes

At work you should always try to adopt a positive and constructive attitude to other people. This can be difficult when you are tired or the person you are relating to is off-hand, aggressive, demanding, and asking for the near impossible. However, they are often under pressure themselves and allowances have to be made. Sometimes people are just out to annoy and provoke a confrontation. Try not to become involved. It is better to walk away from a quarrel than let it get out of hand. Always try to cool the aggressor down.

Sooner or later you are bound to come up against someone with whom you cannot get on. This may be a workmate, or an instructor. Often, there is no apparent reason for this problem, it is simply a clash of incompatible personalities. If you cannot resolve the matter amicably yourself, don't leave the situation to deteriorate, but seek advice from the appropriate member of staff such as your supervisor or manager. He or she may be able to solve the problem even if it may involve you being moved to another section. Remember that, during your training, your personal attitudes and your ability to work as a team member is as much under scrutiny as the engineering products that you produce.

2.5.2 Teamwork

Quite often you will have to work as a member of a team. This requires quite different skills in interpersonal relationships than when you are working on your own or under the guidance of your instructor. For example, consider the lifting of a large and heavy packing case when mechanical lifting gear is not available. Like any team, the lifting party has to have a team leader (captain). That person must have the respect and confidence of all the other members of the team because of his or her experience and expertise. The team should be picked from people who it is known can work together amicably and constructively. One oddball going his or her own way at a crucial moment could cause an accident and injury to other members of the team.

Although the team leader is solely responsible for the safe and satisfactory completion of the task, he or she should be sensible enough to consider comments and contributions from other members of the team. If you are a member of such a team and you think you have spotted a potential hazard in the job to be done, then it is your duty to draw it to the attention of the team leader. Eventually, however, discussion has to cease and the job has to be done. At this point the team leader has to make up his or her mind about how the job is to be done.

The team leader should not take an active part in the exercise, but should stand back where he or she can see everything that is going on. So, in the event of a potentially hazardous situation developing, the team

leader is free to step in and correct the situation in order to prevent an accident.

2.5.3 Personal property

During a working lifetime most engineers acquire an extensive set of personal tools. Some may be bought and some may be made personally. You will be mightily unpopular in any workshop if you borrow any of these tools without the owner's consent. The same applies to overalls or any other personal belongings. Although we have considered company policy, each and every workshop has a code of conduct all of its own. This is not written down, it is not company policy, it is a code of behaviour that has grown up over the years amongst the people working in that shop. Woe betide anyone who disregards this code of conduct. However, respect it, obey it, and you will find that your relationships with your workmates and supervisors will be much more pleasant. You will receive more useful help and wise advice and will establish worthwhile friendships that can stand you in good stead throughout your working life.

Exercises

2.1 *Effective working relationships*

- (a) You are engaged in an intricate machining operation when a colleague asks for your assistance. Explain how you would deal with this situation.
- (b) You are having difficulty in understanding an engineering drawing and you want advice. Your instructor is engaged in conversation with the training manager. Explain what you should do in this situation.
- (c) Your supervisor has directed you to help with a team activity in another department. Explain how you would introduce yourself to the team leader and how you would try to relate to the other members of the team.

2.2 *Dress, presentation and behaviour*

- (a) Describe the dress code at your place of work or your training centre and explain why the dress code should be adhered to.
- (b) Explain THREE possible consequences of 'fooling about' in an engineering workshop.
- (c) Explain why you, as an engineering trainee, should:
 - (i) adopt a short, neat hair style;
 - (ii) not wear dirty overalls;
 - (iii) write up your logbook carefully and neatly, keep it in a plastic folder, and make sure it is available on demand for examination by your supervisor.

2.3 *Instructions*

- (a) Draw an organization chart to show the chain of command in your training centre or in a company with which you are familiar.
- (b) Upon receiving a verbal instruction, describe what you would do to ensure that you have understood it correctly.

- (c) If a written instruction is unclear or badly printed, describe what you would do to avoid making a mistake in carrying out the instruction.

2.4 *How to ask for help*

- (a) Describe a situation where your instructor might have sent you to another person, such as a more senior colleague, for advice. Explain who that person might be in your training centre or company.
- (b) To avoid bothering your instructor when he or she is busy, describe:
 - (i) the sort of practical assistance you might seek from a colleague;
 - (ii) the sort of information you might seek from a colleague.
- (c) State whom you would approach for advice, and why you have chosen that person, in the following circumstances:
 - (i) clarification of instructions or unclear advice from a colleague;
 - (ii) safe working practice concerning a new material that has been introduced into the workshop;
 - (iii) assistance in completing forms;
 - (iv) reporting personal injuries and accidents;
 - (v) discussing personal problems.
- (d) Give ONE example of the *correct approach* to another person when seeking that person's help or advice, and ONE *inappropriate approach* to another person when seeking that person's help or advice.

2.5 *How to give help when asked*

- (a) List FIVE important criteria that you must remember when giving help or advice to another person.
- (b) Describe THREE situations when you should refuse to offer help or advice.
- (c) Explain how you would try to make such a refusal without giving offence.

2.6 *Reporting deficiencies in tools, equipment and materials*

- (a) Give FIVE reasons why it is necessary to report deficiencies in tools, equipment and materials.
- (b) Briefly describe the procedures used in your training centre or company for reporting defective tools, equipment and materials.

2.7 *Respect for other people's opinions and property*

- (a) You may have to work with people whose values on work and life in general disagree with your own. Should you:
 - (i) argue aggressively with them? OR
 - (ii) respect their views despite your personal reservations?
- (b) You are in a hurry and a long way from the stores. You know that your workmate has the equipment you need in his or her personal toolkit. Describe the correct procedure for borrowing and returning such equipment.

- (c) You are in a hurry to get home at the end of your shift. You are returning the tools you have been using to the stores. Should you clean them and check them or leave that to the stores personnel to save yourself time? Give reasons for your answer.

2.8 *Teamwork and co-operation*

- (a) Why is it necessary to take the time and trouble to gain some knowledge and understanding of what other people do in your training centre or company, both within your department and in other departments? How could this lead to improved co-operation and teamwork?
- (b) How do some companies expand their trainees' and apprentices' insight into the work of other departments in the organization?
- (c) Give reasons for your answers to the following. When working as a team:
 - (i) should you take part in discussions concerning the work to be done?
 - (ii) should you ask for clarification of matters you do not understand?
 - (iii) from whom should you take instructions?

2.9 *Difficulties in working relationships*

- (a) State FIVE possible *causes* of difficulty that may arise in your relationships with your workmates and more senior staff.
- (b) With whom should you discuss such problems in the first place?
- (c) Describe the procedures that exist for formally reporting such difficulties in your training centre or company if you can get no satisfaction from (b) above.

3 Handling engineering information

When you have read this chapter you should understand how to:

- Select information sources to undertake work tasks.
- Extract, interpret and evaluate engineering information.
- Record and process engineering information.

3.1 Selection of information sources

The need for clear communications that cannot be misinterpreted was introduced in Chapter 2. It is necessary therefore to select means of communication and information sources that ensure that the correct information is provided and used. Engineering drawings are used to transmit and receive information concerning components to be manufactured and assembled. Engineering drawings will be considered in detail in Chapter 5. However, some information has to be given in writing. For example:

- Manufacturing instructions such as the name of the parts to be made, the number required, any special finishes required and the date by which they are required.
- Technical data such as screw thread sizes, and manufacturers' recommended cutting speeds and feeds.
- Stock lists such as material sizes, standard 'bought-in parts', and standard cutting tools.
- Training logbooks.

Verbal instructions and telephone messages should be confirmed in writing or by fax. The latter is particularly useful if illustrations are involved. In industry and commerce all information must be produced in a way that is:

- Easy to understand with no risk of errors.
- Complete, with no essential details missing.
- Quick and easy to complete.

These goals are best achieved by the use of standardized forms. By providing much of the information in the form of boxes that can be ticked, even the interpretation of hand writing that is difficult to read is overcome.

Manufacturing organizations are concerned with making the goods required by their customers at a price their customers are prepared to

pay, and in delivering those goods in the correct quantities at the correct time. This involves teamwork within the organizations and close liaison with their customers and suppliers, and can only be achieved by the selection of efficient communication and the efficient handling of engineering information.

3.2 Interpretation of information (graphical)

There are many ways in which information can be presented and it is essential to select the most appropriate method. This will depend upon such factors as:

- The information itself.
- The accuracy of interpretation required.
- The expertise of the audience to whom the information is to be presented.

Much of the information required for the manufacture of engineering products is numerical. This can be presented in the form of tables where precise information is required concerning an individual item. Sometimes, all that is required is a general overview of a situation that can be seen at a glance. In this case the numerical data is most clearly presented by means of graphs and diagrams. There are many different types of graph depending upon the relationship between the quantities involved and the numerical skills of the user group at which the graph is aimed. Let's look at some graphs in common use.

3.2.1 Line graphs

Figure 3.1(a) shows a graph for the relationship drill speed and drill diameter for a cutting speed of 15 m/min. In this instance it is in order to use a continuous curve flowing through the points plotted. This is because the points plotted on the graph are related by a mathematical expression and any value of drill speed or drill diameter calculated from that expression will lie on the curve.

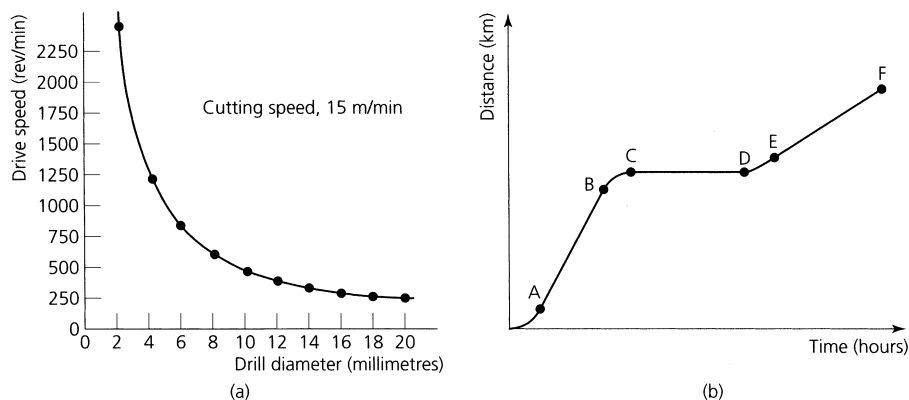


Figure 3.1 Line graphs: (a) points connected by a smooth curve (point related mathematically); (b) points connected by straight lines

This is not true in every instance as shown by Fig. 3.1(b). This graph connects time and distance travelled for a vehicle.

- From A to B the distance travelled is proportional to the time taken. That is, the straight line indicates that the vehicle is travelling with a constant speed.
- The curved bit at the beginning of the line shows that the vehicle was accelerating from a standing start. The curved bit at the end shows that the vehicle slowed down smoothly to a stop.
- From C to D there is no increase in distance with time. The vehicle is stationary.
- From E to F the vehicle recommences its journey at a reduced speed since the line slopes less steeply.

In this graph it is correct for the points to be connected by separate lines since each stage of the journey is unrelated to the previous stage or to the next stage. It would have been totally incorrect to draw a flowing curve through the points in this instance.

3.2.2 Histograms

Figure 3.2 shows the number of notifiable accidents which occur each year in a factory over a number of years. The points cannot be connected by a smooth, continuous curve as this would imply that the statistics follow some mathematical equation. Neither can they be connected by a series of straight lines. This would imply that, although the graph does not represent a mathematical equation, the number of accidents increased or decreased continuously and at a steady rate from one year to the next. In reality the number of accidents is scattered throughout the year in a random manner and the total for one year is independent of the total for the previous year or the next year. The correct way to present this information is by a histogram as shown.

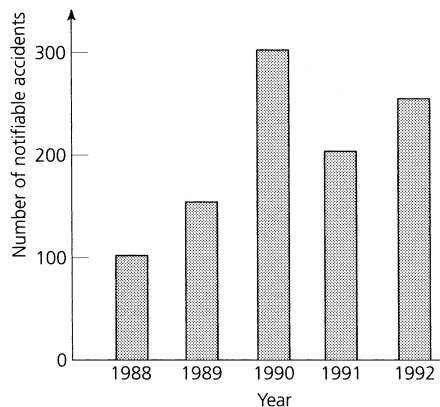


Figure 3.2 *Histogram*

3.2.3 Bar charts

These are frequently used for indicating the work in progress and they are used in production planning. An example is shown in Fig. 3.3.

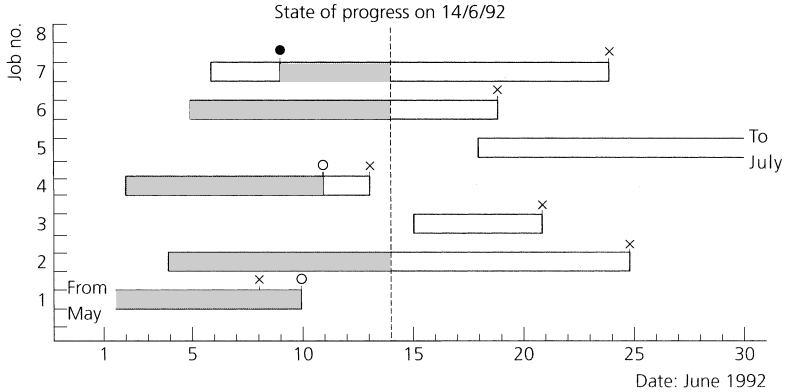


Figure 3.3 Bar chart: x = scheduled completion date; o = actual completion date; • = start delayed; shaded area = work completed to date

3.2.4 Ideographs (pictograms)

These are frequently used for presenting statistical information to the general public. In Fig. 3.4 each symbol represents 1000 cars. Therefore in 1990, the number of cars using the visitors' car park at a company was 3000 (1000 cars for each of three symbols). Similarly, in 1991 the number of cars using the car park was 4000 and in 1992 the number had risen to 6000.

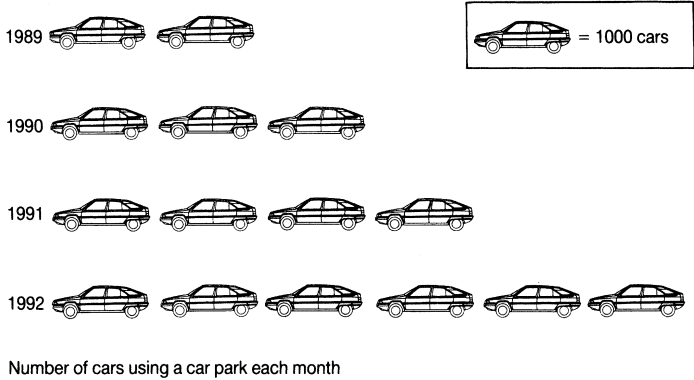


Figure 3.4 Ideograph (pictogram): number of cars using a car park each month

3.2.5 Pie charts

These are used to show how a total quantity is divided into its individual parts. Since a complete circle is 360° , and this represents the total, then a 60° sector would represent $60/360 = 1/6$ of the total. This is shown in Fig. 3.5(a). The total number of castings produced by a machine company's foundry divided up between the various machines manufactured can be represented by a pie chart as shown in Fig. 3.5(b).

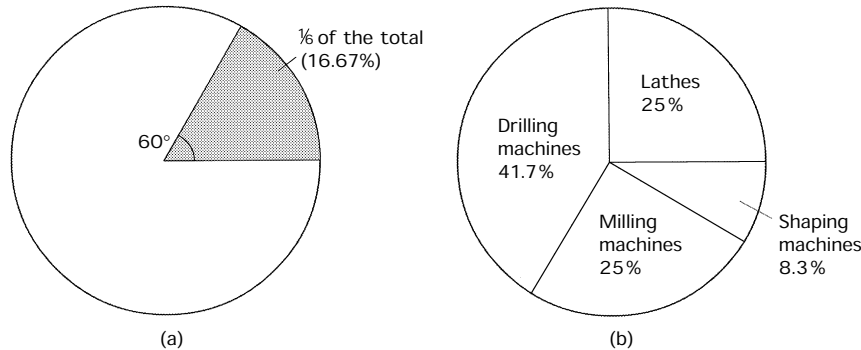


Figure 3.5 *Pie chart*

3.3 Interpretation of information (tables, charts and schedules)

3.3.1 Manufacturers' catalogues

Manufacturers' catalogues and technical manuals are an essential means of keeping up to date with suppliers' product lines. Also such catalogues and technical manuals usually include performance data and instructions for the correct and most efficient use for the products shown.

3.3.2 British and European Standards

At the start of the industrial revolution there was no standardization of components. Every nut and bolt was made as a fitted pair and was not interchangeable with any other nut and bolt. Imagine finding a box full of nuts and bolts of seemingly the same size and having to try every nut on every bolt until you found which nuts fitted which bolts. No wonder that screwed fasteners were the first manufactured goods to be standardized, although initially only on a national basis.

Modern industry requires a vast range of standardized materials and components to provide the interchangeability required for international trading and uniformity of quality. Initially this work was carried out by such organizations as the British Standards Institute (BSI) in the UK, by DIN in Germany, and by ANSI in America. Since 1947, the International Standards Organization (ISO) has been steadily harmonizing *national standards* and changing them into *international standards* in order to promote international trading in manufactured goods. The aims of standardization as defined by the BSI are:

- The provision of efficient communication amongst all interested parties. The promotion of economy in human effort, materials and energy in the production and exchange of goods through the mass production of standardized components and assemblies.
- The protection of consumer interests through adequate and consistent high quality of goods and consumer services.
- The promotion of international trade by the removal of barriers caused by differences in national practices.

3.3.3 Production schedules

These are usually in the form of bar charts or computer listings. The former will show the planned start and finish dates for various jobs and the machines onto which they are to be loaded. The actual progress of the jobs is superimposed on the ideal schedule so that any 'slippage' in production and the reason can be seen at a glance so that remedial action can be taken and, if necessary, the customer advised of possible delay. An example was shown in Fig. 3.3. Computer listings of production schedules and stock balances are updated regularly (on a daily basis) so that the sales staff of a company know what components and assemblies are in stock, and how soon new stock should be available if a particular item has sold out.

3.3.4 Product specifications

In addition to scheduling the work that is to be done, it is also necessary to issue full instructions to the works concerning the product to be made. That is, a *production specification* must be issued. For example, let's consider a car production line. It is set up to produce a continuous flow of a particular type of car. However, within that basic work pattern there are many variations. For example, some will have one colour and others will be different. Some will have one trim, others will have another. Some will have power steering, others will not, and so on. Therefore each car built will have a product specification, so that the customer will get the car he or she has chosen.

On a simpler basis is the *works order* issued in a batch production or in a jobbing workshop. This provides the information needed to manufacture a batch of components. An example of such a works order form is shown in Fig. 3.6.

The example shown provides the following information:

- It identifies the component to be made.
- It identifies the drawings to be used.
- It states the quantity of the product to be made.
- It specifies the material that is to be used.
- It specifies any special jigs, fixtures, tools and cutters that will be needed and their location in the stores.

ABC Engineering Co. Ltd		Job No.
Date issued	Date required	
Component		
Drawing numbers		
Quantity		
Material size	Type	Quantity
Tooling		
Finish/Colour		
Date commenced	Date finished	Operator
Inspection report		Inspector
Special requirements		
Destination		Authorised by

Figure 3.6 *Typical works order form*

- It specifies any heat treatment and finishing process that may be required.
- It specifies the issue date for the order and the date by which it is required.
- It specifies the destination of the job (stores, inspection department, etc.).
- It includes any special variations required by a particular customer.
- It identifies the personnel employed in the manufacture and the inspection of the job.
- It carries the signature that gives the managerial authority for the work to be done.
- It provides room for the actual dates to be inserted when the job was commenced, and when it finished.

You will notice that all this information is entered on a standard form. This saves time in issuing the information. It is much easier to fill in the blanks than to have to write out all the information from scratch. It is

also easy to see if a 'box' is blank. This would indicate that a vital piece of information is missing. It is also easier for the person doing the job to see exactly what is required since the same sort of information always appears in the same place on the form every time.

3.3.5 Reference tables and charts

There are a number of 'pocketbooks' published for the different branches of engineering. A typical 'pocketbook' for use in manufacturing workshops would contain tables of information such as:

- Conversion tables for fractional to decimal dimensions in inch units, and conversion tables for inch to metric dimensions.
- Conversion tables for fractional (inch), letter, number and metric twist drill sizes.
- Standard screw thread and threaded fastener data tables.
- Tables for spacing holes around pitch circles as an aid to marking out.
- Speeds and feeds for typical cutting tool and workpiece material combinations for different processes.

This list is by no means exhaustive but just a brief indication of the sort of useful data provided. In addition, many manufacturers produce wall charts of similar data as it affects their particular products. These are not only more convenient for the user than having to open and thumb through a book with oily hands, but they are also good publicity for the manufacturers who issue them.

3.3.6 Drawings and diagrams

Engineers use drawings and diagrams to communicate with each other and with the public at large. The type of drawing or diagram will depend upon the audience it is aimed at and their ability to correctly interpret such information. The creation and interpretation of engineering drawings is considered in detail in Chapter 5.

3.4 Evaluating engineering information

Keep alert for errors in the information given. Suppose you have made several batches of a component from stainless steel and suddenly the works order form specifies silver steel. Is this a genuine change or a clerical error? So, the manager has signed it, but he is a very busy person and he may have missed the error. Therefore check with your supervisor before starting the job. Better to be sure than sorry.

If standards are referred to check that the issue on the shop floor is up to date. Standard specifications and EU regulations change rapidly these days. Out of date editions should be withdrawn immediately and the latest edition issued. However, it is surprising how long an out of date copy can keep circulating before someone spots it and destroys it.

3.5 Recording and processing engineering information

The need for, and importance of, accurate record keeping is increasing all the time in nearly all the areas of company activity. Let's now look at some of the more important aspects that affect all employees.

3.5.1 Quality control

Quality control now affects nearly all the manufacturing companies both large and small. This is because a firm that wants to sell its goods to a BS EN 9000 approved firm must itself be approved and, in turn, obtain its supplies from approved sources. In the UK the British Standard for Quality Assurance is BS EN 9000. The definition of quality upon which this standard is based is in the sense of '*fitness for purpose*' and '*safe in use*', and that the product or service has been designed to meet the needs of the customer.

A detailed study of quality control and total quality management is beyond the scope of this book. However, if you are employed in the engineering industry it is almost inevitable that you are employed in a company that is BS EN 9000 approved and that this will influence your working practices. A key factor in this respect is '*traceability*'. Therefore BS EN 9000 is largely concerned with documentation procedures. All the products needed to fulfil a customer's requirements must be clearly identifiable throughout the organization. This is necessary in order that any part delivered to a customer can have its history traced from the source from which the raw material was purchased, through all the stages of manufacture and testing, until it is eventually delivered to the customer. This is shown diagrammatically in Fig. 3.7.

The need for this *traceability* might arise in the case of a dispute with a customer due to non-conformity with the product specification, for safety reasons if an accident occurs due to failure of the product, and for statutory and legal reasons. For these reasons, like everyone else involved, your contribution to the above chain of events has to be accurately recorded and the records kept indefinitely. Otherwise the company's goods may not be certified and acceptable to the customer.

3.5.2 Health and safety

This is discussed in detail in Chapter 1. Here, also, record keeping is essential. Some of the documents and data that need to be maintained are:

- the accident register;
- the regular inspection and certification of lifting tackle and pressure vessels (boilers and compressed air receivers);
- dates of fire drills and the time taken to evacuate the premises; records of visits to the premises by local authority fire and safety officers and their reports.

3.5.3 Legal and financial reasons

Registered companies need to keep legal records to comply with the Companies Act. They must publish their Memorandum and Articles of

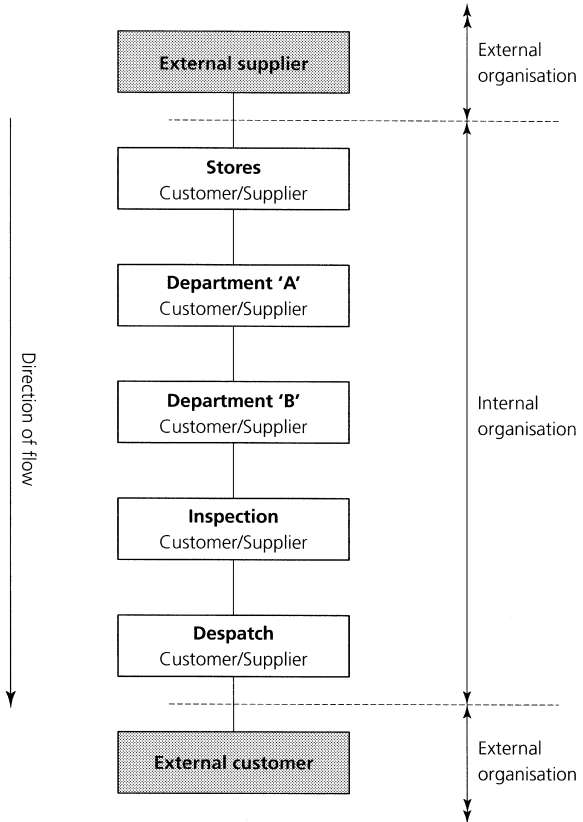


Figure 3.7 *Quality control chain (each stage is a customer of the previous stage and a supplier to the next stage, i.e. Department 'A' is a customer of the stores and a supplier to Department 'B')*

Association and lodge a copy at Companies House when the company is set up. They must keep accurate minutes of all meetings of the board of directors and make annual returns including a current list of directors and other information immediately following each annual general meeting (AGM) of the company.

Similarly it is important that a company keeps accurate and complete financial records so that it can keep its costs under control and ensure that a profit is made. It also needs these records to satisfy the accountants when they make their annual visit to audit the accounts and draw up the balance sheet as required by the directors and shareholders as well as the tax authorities.

3.6 Methods of record keeping

3.6.1 Computer files

Most records are nowadays kept on computer files in the form of magnetic disks, magnetic tapes and optical discs (compact discs). These are easily

destroyed by fire, theft and computer viruses (bugs). For this reason such data should be regularly backed up so that, in an emergency, the data can be reinstated with the minimum of downtime and loss of business. Such backup copies should be kept in a burglar proof and fire proof safe.

3.6.2 Microfilm and microfiche

Paper records are bulky and easily lost and destroyed. Forms and technical drawings can be easily copied onto microfilm or microfiche systems. These can store large quantities of information photographically in a small space. Such material can be conveniently catalogued and, when required, it can be read through a suitable viewer or enlarged to its original size in the form of a photographic print.

3.6.3 Registers and logbooks

Registers are used for various purposes such as recording the maintenance history of machine tools, the testing and inspection of equipment such as lifting gear, pressure vessels and fire extinguishers, accidents to employees, and fire drills. Lorry drivers and sales representatives keep logbooks to maintain records of their journeys. For young trainees, one of the most important documents to be kept is your *training logbook*. The format of logbooks varies from one training establishment to another. No matter what format is chosen, your logbook should:

- Record the training you have undergone.
 - Show details of the exercises you have undertaken and how you carried them out.
 - Show how successfully you have completed each exercise.
 - Show your instructor's comments on your performance and his or her signature verifying the entry.
-

3.7 Communications (miscellaneous)

Safety and hazard notices

There is a saying that *in an emergency people panic in their own language*. Therefore, all safety notices and operating instructions for potentially hazardous plant and processes should be printed in as many languages as there are employees from different ethnic backgrounds. Wherever possible internationally recognized hazard signs should be used.

Safety and hazard signs

All signs must comply with the Safety Signs Regulations 1980. These are recognized internationally and combine geometrical shape, colour and a pictorial symbol to put across the message. Some examples can be found in Section 1.7.2.

Colour coding

This is another means of communication that overcomes language barriers. Table 3.1 shows the colour codes for the contents of gas cylinders. A cylinder that is coloured wholly red or maroon or has a red band round it near the top contains a flammable gas. In the case of red cylinders the name of the gas should also be stated on the cylinder. Maroon coloured cylinders contain only acetylene gas for welding. A cylinder having a yellow band round the top contains a poisonous gas.

TABLE 3.1 *Colour codes for cylinder contents*

<i>Gas</i>	<i>Ground colour of cylinder</i>	<i>Colour of bands</i>
Acetylene	Maroon	None
Air	Grey	None
Ammonia	Black	Red and yellow
Argon	Blue	None
Carbon monoxide	Red (+ name)	Yellow
Coal gas	Red (+ name)	None
Helium	Medium brown	None
Hydrogen	Red (+ name)	None
Methane	Red (+ name)	None
Nitrogen	Dark grey	Black
Oxygen	Black	None

The identification colours for electric cables are shown in Table 3.2. Note that earth conductors are nowadays likely to be referred to as *circuit protective conductors*.

TABLE 3.2 *Colour codes for electrical cables*

<i>Service</i>	<i>Cable</i>	<i>Colour</i>	
Single phase Flexible	Live	Brown	
	Neutral	Blue	
	Earth	Green/yellow	
Single phase Non-flexible	Live	Red	
	Neutral	Black	
	Earth	Green/yellow	
Three phase Non-flexible	Line (live) {	colour	Red
		denotes	White
		phase	Blue
	Neutral	Black	
	Earth	Green/yellow	

Finally, pipe runs and electrical conduits are colour coded according to their contents as listed in Table 3.3. The method of application of the colour code is shown in Fig. 3.8.

TABLE 3.3 *Colour codes for pipe contents*

<i>Colour</i>	<i>Contents</i>
White	Compressed air
Black	Drainage
Dark grey	Refrigeration and chemicals
Signal red	Fire (hydrant and sprinkler supplies)
Crimson or aluminium	Steam and central heating
French blue	Water
Georgian green	Sea, river and untreated water
Brilliant green	Cold water services from storage tanks
Light orange	Electricity
Eau-de-Nil	Domestic hot water
Light brown	Oil
Canary yellow	Gas

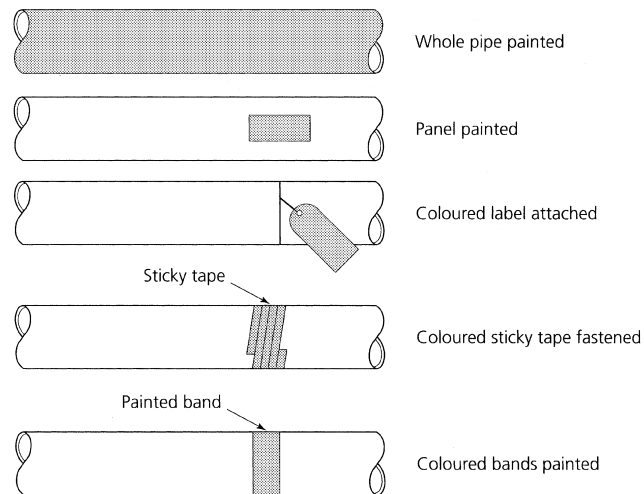


Figure 3.8 *Colour codes for contents of pipes*

Posters

Posters are also used to put over safety messages. They may be humorous or dramatic. The picture reinforces the caption so that the message is clear even for people who cannot read the words for some reason. Such posters should be displayed at strategic points adjacent to the hazard they represent. They should be changed frequently so as to attract attention.

- Exercises**
- 3.1** *Information required to undertake work tasks*
- You have just received the works order form for the next component you are to make. List the essential information you would expect to find on such a form.
 - As well as the works order form, what additional and essential document do you need before you can start the task?
- 3.2** *Interpretation of numerical information*
- Graphs are often used for showing numerical relationships. Sketch suitable graphs to represent the following situations.
 - The relationship between the diameter and cross-sectional area of mild steel rods of 2, 4, 6, 8, 10 and 12 millimetres diameter.
 - The relationship between time and total power in watts for an office that has eight fluorescent electric lights. Each light has a power rating of 80 watts. The lights are turned on, one at a time, at ten minute intervals until they are all on.
 - A firm has the following notable accident record:

1994	15 accidents
1995	24 accidents
1996	12 accidents
1997	7 accidents.
 - With the aid of simple examples explain when you would use the following types of graphical representation.
 - Ideograph (pictogram)
 - Pie chart.
- 3.3** *Extraction and interpretation of engineering information*
- The parts list of a general arrangement drawing specifies the use of a manufacturer's standard drill bush with a bore of 6 mm and an O/D of 12 mm. State where you would look for details of such bushes and list the information you would need to give to the stores so that they could purchase such a bush.
 - What do the following initial letters stand for: BSI, ISO, EN? (Note you may find two uses of the initials EN.) To what do the specifications BS 970 and BS 308 refer?
 - Explain briefly, with the aid of an example, what is meant by a *production schedule*.
 - Give an example of a *product specification* for any product with which you are familiar.
 - Table 3.4 shows an abstract from some screw thread tables. What is the pitch of an M10 thread and what tapping size drill is required for tapping an internal M10 screw thread?
- 3.4** *Evaluation of the accuracy and appropriateness of engineering information*
- Give TWO reasons for cross-checking the accuracy of any reference books that might be lying around in your workshop.
 - To whom should you refer for guidance as to the accuracy and relevance of reference material available in your workshop?

TABLE 3.4 *Exercise 3.3(e)*

<i>150 metric threads (coarse series)</i>	<i>Minor dia. (mm)</i>	<i>Tensile stress area (mm²)</i>	<i>Tapping drill (mm)</i>	<i>ISO Hexagon (mm)</i>
M0.8 × 0.2	0.608	0.31	0.68	–
M1.0 × 0.25	0.675	0.46	0.82	2.5
M1.2 × 0.25	0.875	0.73	1.0	3.0
M1.4 × 0.30	1.014	0.98	1.2	3.0
M1.6 × 0.35	1.151	1.27	1.35	3.2
M1.8 × 0.35	1.351	1.70	1.55	–
M2.0 × 0.40	1.490	2.1	1.70	4.0
M2.2 × 0.45	1.628	2.5	1.90	–
M2.5 × 0.45	1.928	3.4	2.20	5.0
M3.0 × 0.5	2.367	5.0	2.65	5.5
M3.5 × 0.6	2.743	6.8	3.10	–
M4.0 × 0.7	3.120	8.8	3.50	7.0
M4.5 × 0.75	3.558	11.5	4.0	–
M5.0 × 0.8	3.995	14.2	4.50	8.0
M6.0 × 1.0	4.747	20.1	5.3	10.0
M8.0 × 1.25	6.438	36.6	7.1	13.0
M10.0 × 1.50	8.128	58.0	8.8	17.0
M12.0 × 1.75	9.819	84.3	10.70	19.0
M16.0 × 2.00	13.510	157.0	14.5	24.0

3.5 *Recording and processing engineering information*

- (a) State FOUR reasons for, and the importance of, accurate record keeping in a modern factory environment.
- (b) State whether it is a legal requirement to keep a log of notable accidents and, if so, who has the authority to demand access to such a log.
- (c) Describe briefly how quality control is maintained in your company, or your training centre, and what records are required.

3.6 *Methods of record keeping*

- (a) Computer files have superseded many manual filing systems. Why should backup copies of files be kept, and how can these be kept?
- (b) State the purposes for which the following methods of record keeping are used.
 - (i) Logbooks (other than your training logbook).
 - (ii) Forms and schedules.
 - (iii) Photographic (pictorial and dye-line).
 - (iv) Drawings and diagrams.
- (c) Why is it important to keep a training logbook, and why should it be kept carefully, away from dirt and oil, so that it is always clean, neat and tidy?

4 Engineering materials and heat treatment

When you have read this chapter you should understand:

- How to define the basic properties of engineering materials.
- How to correctly identify and select a range of engineering metals and alloys.
- How to correctly identify and select a range of non-metallic materials suitable for engineering applications.
- Safe working practices as applicable to heat treatment processes.
- The principles and purposes of heat treatment.
- The through hardening of plain carbon steels.
- The carburizing and case-hardening of low carbon steels.
- How to temper hardened steels.
- How to anneal and normalize steels.
- The basic heat treatment of non-ferrous metals and alloys.
- The principles, advantages and limitations of heat treatment furnaces.
- The temperature control of heat treatment furnaces.
- The advantages, limitations and applications of quenching media.

4.1 States of matter

Almost all matter can exist in three physical states by changing its temperature in appropriate conditions. These states are solids, liquids and gases.

- Ice is *solid* water and exists below 0°C.
- Water is a *liquid* above 0°C and below 100°C.
- Steam is water *vapour* above 100°C and becomes a *gas* as its temperature is raised further (superheated).

Metals such as brass, copper or steel are solid (frozen) at room temperatures but become liquid (molten) if heated to a sufficiently high temperature. If they are heated to a high enough temperature they will turn into a gas. On cooling, they will first turn back to a liquid and then back to a solid at room temperature. Providing no chemical change takes place (oxidation of the metal through contact with air at high temperatures) we

can change substances backwards and forwards through the three states by heating and cooling as often as we like.

There are exceptions, for example when a thermosetting plastic has been heated during the moulding process it undergoes a chemical change called 'curing'. Once 'cured' it can never again be softened nor turned into a liquid by heating. It can be destroyed by overheating. Another example is the non-metallic element iodine. When heated this *sublimes* directly from a solid to a vapour without becoming a liquid.

With the exception of mercury all metals are solid at normal working temperatures. Metals can be melted into liquids by heating them sufficiently. In the liquid state they can be cast to shape in moulds.

4.2 Properties of materials

To compare and identify engineering materials, it is important to understand the meaning of their more common properties. For example, it is no good saying one material is stronger or harder than another material unless we know what is meant by the terms 'strength' and 'hardness'.

4.2.1 Strength properties

Tensile strength

This is the ability of a material to withstand a stretching load without breaking. This is shown in Fig. 4.1(a). The load is trying to stretch the

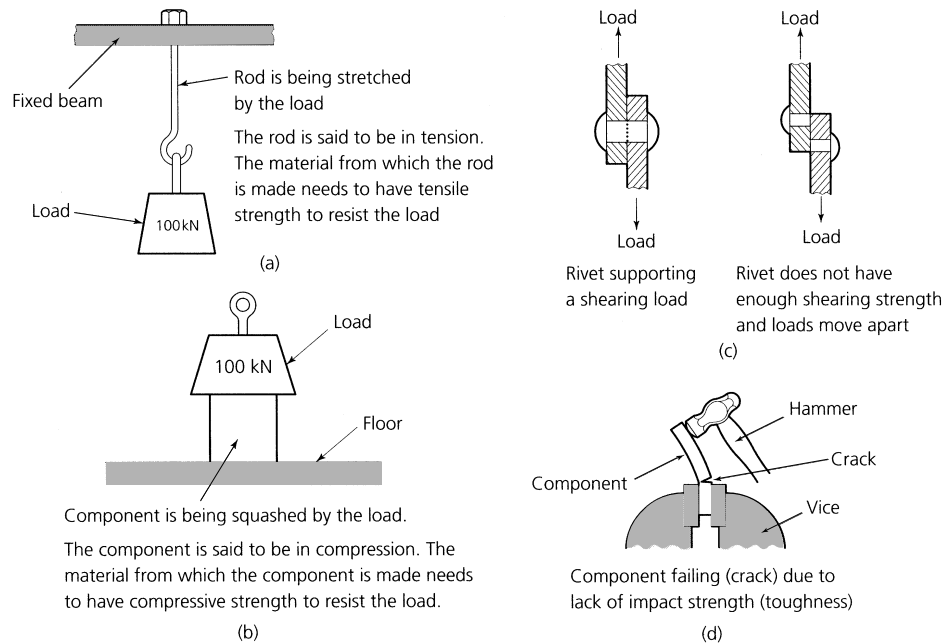


Figure 4.1 *Mechanical properties – strength: (a) tensile strength; (b) compression strength; (c) shear strength; (d) impact strength*

rod therefore the rod is said to be in a *state of tension*. It is being subjected to a tensile load. To resist this load without breaking, the material from which the rod is made needs to have sufficient *tensile strength*.

Compressive strength

This is the ability of a material to withstand a squeezing load without breaking. This is shown in Fig. 4.1(b). The load is trying to squash (crush or compress) the material from which the component is made, therefore the component is said to be in a *state of compression*. It is being subjected to a compressive load. To resist this load without breaking, the material from which it is made needs to have sufficient *compressive strength*.

Shear strength

This is the ability of a material to withstand an *offset* load without breaking (shearing). This is shown in Fig. 4.1(c). The loads are trying to pull the joint apart and the rivet is trying to resist them. The loads are not in line, but are offset. The rivet is subjected to a shear load. The material from which it is made must have sufficient *shear strength* or the rivet will fail as shown, and the loads will move apart. The rivet is said to have *sheared*. The same effect would have occurred if the loads had been pushing instead of pulling.

Note: Riveted joints should be designed so that the load always acts in shear across the shank of the rivet as shown. It must never pull on the heads of the rivet. The heads are intended only to keep the rivet in place.

Toughness

The ability of a material to withstand an impact load. This is shown in Fig. 4.1(d). The impact loading is causing the metal to crack. To resist this impact loading without breaking, the material from which it is made needs to have sufficient *toughness*. Strength and toughness must not be confused. Strength refers to tensile strength – the ability to withstand an axial pulling load. For example, when you buy a rod of high carbon steel (e.g. silver steel) it is in the soft condition and it is strong and tough. It has a relatively high tensile strength and its toughness will enable it to withstand relatively high impact loading before it cracks.

If this metal is quench-hardened (Section 4.16) its *tensile strength* will have greatly *increased*, it will also have become very *brittle*. In this hard and brittle condition it will now break with only a light tap with a hammer – it can *no longer resist impact loads* – it has *lost its toughness*.

Brittleness

We have just mentioned brittleness. This property is the opposite of toughness. It is the ability to shatter when subject to impact. For example, the way a glass window behaves when struck by a cricket ball.

Rigidity

This property is also referred to as stiffness. This is the ability of a metal to retain its original shape under load. That is, to resist plastic or elastic deformation. Cast iron is an example of a rigid material. Because it is rigid and because it can be cast into intricate shapes, it is a good material for use in making the beds and columns for machine tools.

4.2.2 Forming properties**Elasticity**

This property enables a material to change shape under load and to return to its original size and shape when the load is removed. Components such as springs are made from elastic materials as shown in Fig. 4.2(a). Note that springs will only return to their original length providing they are not overloaded.

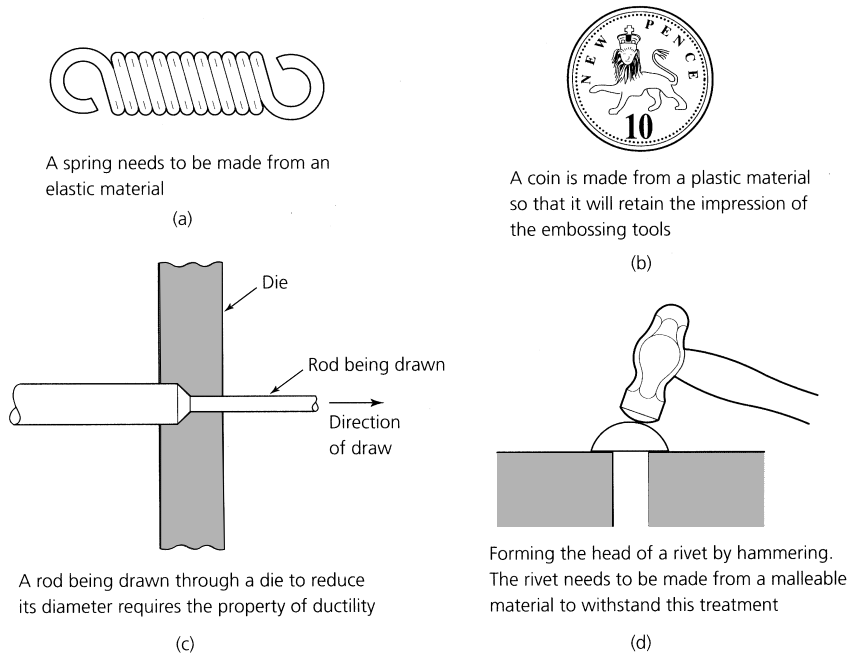


Figure 4.2 *Mechanical properties – flow: (a) elasticity; (b) plasticity; (c) ductility; (d) malleability*

Plasticity

This property enables a material to deform under load and to retain its new shape when the load is removed. This is shown in Fig. 4.2(b). The coin is made from a copper alloy that is relatively soft and plastic. It takes the impression of the dies when compressed between them, and retains that impression when the dies are opened. When the deforming

force is tensile as when wire drawing, the property of plasticity is given the special name *ductility*. When the deforming force is compressive, for example when coining, the property of plasticity is given the special name *malleability*.

Ductility

As stated above, this property enables a material to deform in a plastic manner when subjected to a tensile (stretching) force. For example, when wire drawing as shown in Fig. 4.2(c). Also, the bracket shown in Fig. 4.2(c) requires a ductile material. The outer surface of the material stretches as it bends and is in a state of tension. At the same time the material must remain bent when the bending force is removed so it must be plastic. A *ductile* material combines *tensile strength* and *plasticity*. Note that even the most ductile of metals still show a degree of elasticity. Therefore, when bending the bracket to shape, it must be bent through slightly more than a right angle. This ‘overbend’ allows for any slight ‘springback’.

Malleability

As stated above, this property enables a material to deform in a plastic manner when subjected to a compressive (squeezing) force. For example, when forging or when rivet heading as shown in Fig. 4.2(d). The material must retain its shape when the compressive force is removed so it must be plastic. A *malleable* material combines *compressive strength* and *plasticity*.

Hardness

This is the ability of a material to resist scratching and indentation. Figure 4.3 shows a hard steel ball being pressed into the surface of two pieces of material using the same standard load. When pressed into a hard material, the ball makes only a shallow indentation. When pressed into a soft material, under the same test conditions, the ball sinks into the material further and makes a deeper impression. This is the basic principle of all standard hardness tests.

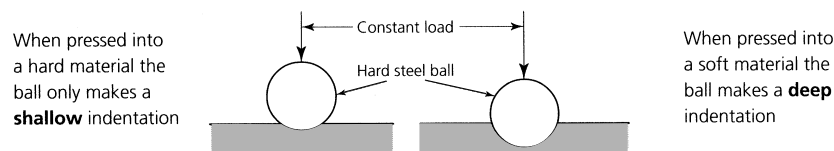


Figure 4.3 *Hardness*

4.2.3 Heat properties

Heat conductivity

This is the ability of a material to conduct heat. Metals are good conductors of heat and non-metals are poor conductors of heat. Figure 4.4(a)

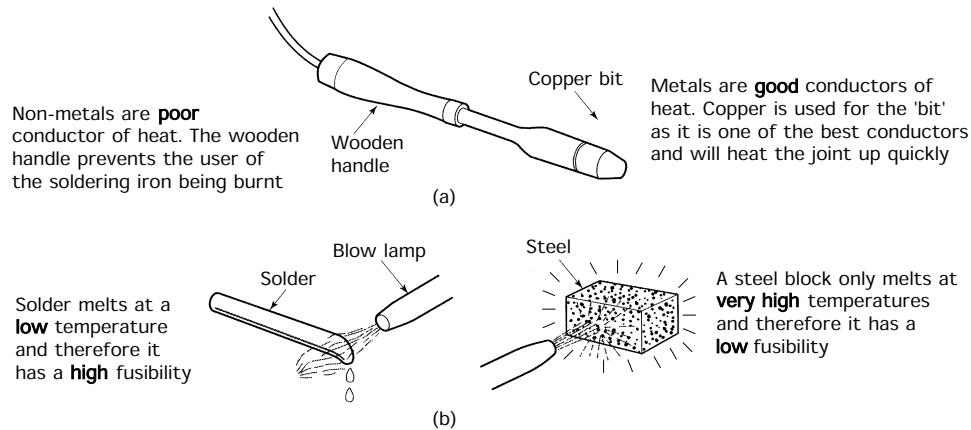


Figure 4.4 Heat properties: (a) heat conductivity; (b) fusibility

shows an electrically heated soldering iron. The bit is made of copper because this is the best of the common metals for conducting heat. It conducts the heat from the heating element to the joint to be soldered. Copper also has an affinity for soft solder so it can be easily 'tinned'. The handle is made of wood or plastic as these materials are easily shaped and are poor conductors of heat. They are heat-insulating materials. They keep cool and are pleasant to handle.

Refractoriness

You must not mix up poor heat conductivity with good refractory properties. *Refractory* materials are largely unaffected by heat. The firebricks used in furnaces are refractory materials. They do not burn or melt at the operating temperature of the furnace. They are also good heat-insulating materials. However, the plastic or wooden handle of the soldering iron shown in Fig. 4.4(a) had good heat-insulating properties but these are not refractory materials since plastics and wood are destroyed by high temperatures.

Fusibility

This is the ease with which materials melt. Soft solders melt at relatively low temperatures; other materials melt at much higher temperatures. Figure 4.3(b) shows the effect of turning a gas blowpipe onto a stick of soft solder. The solder quickly melts. The same flame turned onto a block of steel makes the steel hot (possibly red-hot) but does not melt it.

- The soft solder *melts at a relatively low temperature* because it has *high fusibility*.
- The steel *will not melt* in the flame of the blowpipe because it has *low fusibility* and will melt only at a very *high temperature*.

4.2.4 Corrosion resistance

This is the ability of a material to withstand chemical or electrochemical attack. A combination of such everyday things as air and water will chemically attack plain carbon steels and form a layer of rust on its exposed surfaces. Stainless steels are alloys of iron together with carbon, nickel and chromium; they will resist corrosion. Many non-ferrous metals are corrosion resistant which is why we use copper for waterpipes, and zinc or lead for roofing sheets and flashings.

4.2.5 Hot and cold working

Metals can be cast to shape by melting them and pouring them into moulds. Metals can also be cut to shape by using hand tools and machine tools. However, there is the alternative of *working* them to shape. This is how a blacksmith shapes metal by hammering it to shape on the anvil. Metals that have been shaped by working (also called ‘flow forming’) are said to be *wrought*.

Metals may be worked hot or cold. In either case the crystalline structure of the metal is distorted by the working process and the metal becomes harder, stronger and less ductile.

- In *cold-working* metals the crystalline structure (grain) becomes distorted due to the processing and remains distorted when the processing has finished. This leaves the metal harder, stronger and less ductile. Unfortunately, further cold working could cause the metal to crack.
- In *hot-working* metals the grain also becomes distorted but the metal is sufficiently hot for the grains to reform as fast as the distortion occurs, leaving the metal soft and ductile. Some grain refinement will occur so that the metal should be stronger than at the start of the process. The metal is easier to work at high temperatures and less force is required to form it. This is why the blacksmith gets his metal red-hot before forging it to shape with a hammer.
- *Recrystallization* is the term used when the distorted grains reform when they are heated. The temperature at which this happens depends upon the type of metal or alloy and how severely it has been previously processed by cold working.
- *Cold working* is the flow forming of metal *below* the temperature of recrystallization. For example, cold heading rivets.
- *Hot working* is the flow forming of metals *above* the temperature of recrystallization. For example, rolling red-hot ingots into girders in a steel mill.

Figure 4.5 shows examples of hot and cold working, and Tables 4.1 and 4.2 summarize the advantages and limitations of hot- and cold-working processes.

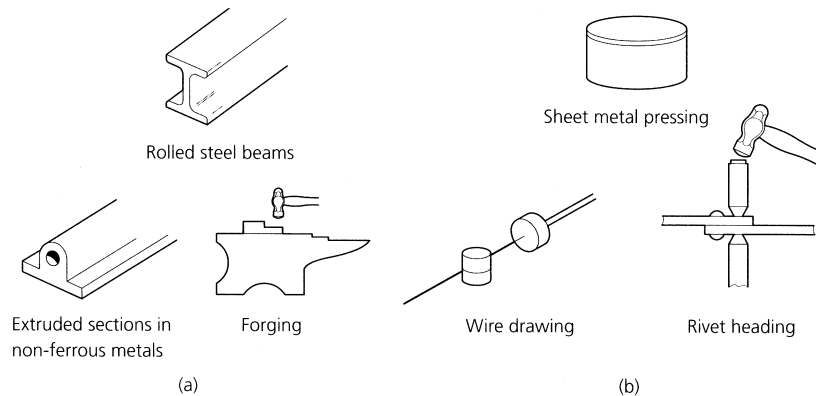


Figure 4.5 Examples of (a) hot-working and (b) cold-working processes

TABLE 4.1 Hot-working processes

<i>Advantages</i>	<i>Limitations</i>
<ol style="list-style-type: none"> 1. Low cost 2. Grain refinement from cast structure 3. Materials are left in the fully annealed condition and are suitable for cold working (heading, bending, etc.) 4. Scale gives some protection against corrosion during storage 5. Availability as sections (girders) and forgings as well as the more usual bars, rods, sheets, strip and butt-welded tube 	<ol style="list-style-type: none"> 1. Poor surface finish – rough and scaly 2. Due to shrinkage on cooling the dimensional accuracy of hot-worked components is of a low order 3. Due to distortion on cooling and to the processes involved, hot working generally leads to geometrical inaccuracy 4. Fully annealed condition of the material coupled with a relatively coarse grain leads to a poor finish when machined 5. Low strength and rigidity for metal considered 6. Damage to tooling from abrasive scale on metal surface

TABLE 4.2 Cold-working processes

<i>Advantages</i>	<i>Limitations</i>
<ol style="list-style-type: none"> 1. Good surface finish 2. Relatively high dimensional accuracy 3. Relatively high geometrical accuracy 4. Work hardening caused during the cold-working processes: <ol style="list-style-type: none"> (a) increases strength and rigidity (b) improves the machining characteristics of the metal so that a good finish is more easily achieved 	<ol style="list-style-type: none"> 1. Higher cost than for hot-worked materials. It is only a finishing process for material previously hot worked. Therefore, the processing cost is added to the hot-worked cost 2. Materials lack ductility due to work hardening and are less suitable for bending, etc. 3. Clean surface is easily corroded 4. Availability limited to rods and bars also sheets and strip, solid drawn tubes

4.3 Classification of materials

Almost every known substance has found its way into the engineering workshop at some time or other. Neither this chapter nor in fact the whole of this book could hold all the facts about all the materials used by engineers. Therefore, to keep things simple, first these materials are grouped into similar types and then the properties and uses of some examples from each group will be considered. These main groups are shown in Fig. 4.6.

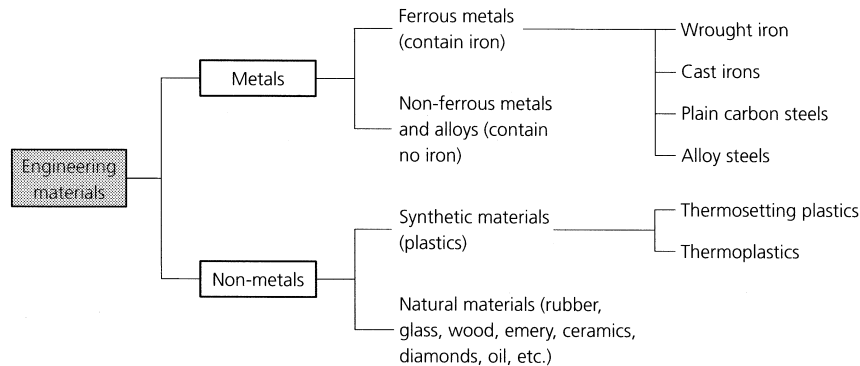


Figure 4.6 Classification of engineering materials

4.3.1 Metals

For the purposes of this book, we can consider metals as substances that have a lustrous sheen when cut, are good conductors of heat, and are good conductors of electricity. Some examples are aluminium, copper and iron. Sometimes metals are mixed with non-metals. For example, cast irons and plain carbon steels are mixtures of iron and carbon with traces of other elements. Sometimes metals are mixed with other metals to form *alloys*. For example, brass is an alloy of copper and zinc.

4.3.2 Non-metals

These can be elements, compounds of elements and mixtures of compounds. They include wood, rubber, plastics, ceramics and glass. Some materials are compounds of metals and non-metals. For example, naturally occurring abrasive grits, such as emery and corundum contain between 70% and 90% of aluminium oxide (a compound of aluminium and oxygen). Aluminium oxide (also known as alumina) is used in firebricks for furnace linings.

Organic compounds are based on the element *carbon* chemically combined with other substances. Some examples of organic materials are natural materials such as wood and some rubbers, and synthetic materials such as plastics.

4.4 Ferrous metals (plain carbon steels)

Ferrous metals and alloys are based on the metal *iron*. They are called ferrous metals because the Latin name for iron is *ferrum*. Iron is a soft

grey metal and is rarely found in the pure state outside a laboratory. For engineering purposes the metal iron is usually associated with the non-metal carbon.

4.4.1 Plain carbon steels

Plain carbon steels, as their name implies, consist mainly of iron with small quantities of carbon. There will also be traces of impurities left over from when the metallic iron was extracted for its mineral ore. A small amount of the metal manganese is added to counteract the effects of the impurities. However, the amount of manganese present is insufficient to change the properties of the steel and it is, therefore, not considered to be an alloying element. Plain carbon steels may contain:

- 0.1% to 1.4% carbon
- up to 1.0% manganese (not to be confused with magnesium)
- up to 0.3% silicon
- up to 0.05% sulphur
- up to 0.05% phosphorus

Figure 4.7 shows how the carbon content of a plain carbon steel affects the properties of the steel. For convenience we can group plain carbon steels into three categories:

- low carbon steels (below 0.3% carbon);
- medium carbon steels (0.3% to 0.8% carbon);
- high carbon steels (between 0.8% and 1.4% carbon).

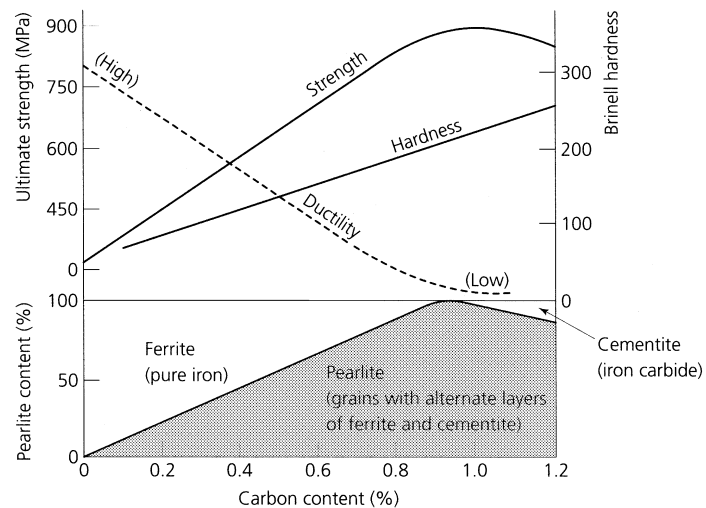


Figure 4.7 *The effect of carbon content on the properties of plain carbon steels*

4.4.2 Low carbon steels

These are also referred to as mild steels. If the carbon content is kept between 0.1% and 0.15% the steel is often referred to as 'dead mild' steel. This steel is very ductile and very soft, and can be pressed into complicated shapes for car body panels at room temperature without cracking. It is not used for machined components since its softness would cause it to tear and leave a poor surface finish. It is slightly weaker than the next group of low carbon steels to be considered.

If the carbon content is between 0.15% and 0.3% the steel is stronger, but slightly less soft and ductile. It is often referred to as 'mild' steel. It can be forged, rolled and drawn both in the hot and in the cold condition. It is easily machined with high-speed steel cutting tools. Because of its ease of manufacture and the very large quantities produced, mild steels are the cheapest and most plentiful of the steel products. Hot worked mild steel is available as structural sections (girders, reinforcing rods and mesh for concrete), forgings, sheet, strip, plate, rods, bars and seam-welded tubes. Cold worked mild steel – also known as bright drawn mild steel (BDMS) – is available as bright drawn bars and rods; solid drawn tubes; sheet and strip, and formed wire goods.

Some low carbon steels contain additives such as lead or sulphur to make them 'free-cutting'. The greatly improved machining properties imparted by these additives are achieved only at the expense of the strength and toughness of the steel.

4.4.3 Medium carbon steels

There are two groups of medium carbon steels:

- 0.3% to 0.5% carbon. These can be heat treated to make them tough and strong.
- 0.5% to 0.8% carbon. These can be heat treated to make them fairly hard yet retain a degree of toughness (impact resistance).

Medium carbon steels are harder, stronger and tougher than low carbon steels. They are also more expensive. They cannot be bent or formed in the cold condition to the same extent as low carbon steels without cracking. However, medium carbon steels hot forge well, but close temperature control is required to prevent:

- 'Burning' at high temperatures over 1150°C, as this leads to embrittlement. The metal cannot be reclaimed and the forging has to be scrapped.
- Cracking when forging is continued below 700°C. Cracking is due to work hardening as the steel is in the 'cold' condition from a forging point of view.

Medium carbon steels with a carbon content in the 0.3 to 0.5% range are used for such products as drop-hammer die blocks, laminated springs, wire ropes, screwdriver blades, spanners, hammer heads and heavy duty forgings.

Medium carbon steels with a carbon content in the 0.5 to 0.8% range are used for such products as wood saws, cold chisels, forged blanks for connecting rods, crankshafts, gears and other stressed components such as high-tensile pipes and tubes.

4.4.4 High carbon steels

These are harder, less ductile and more expensive than both mild and medium carbon steels. They are also less tough and are mostly used for springs, cutting tools and forming dies. High carbon steels work-harden readily and, for this reason, they are not recommended for cold working. However, they forge well providing the temperature is controlled at between 700°C and 900°C. There are three groups of high carbon steels:

- 0.8% to 1.0% carbon where both toughness and hardness are required. For example, sheet metal pressing tools where the number of components to be produced does not warrant the cost of expensive alloy steels. Also, cold chisels for fine work, some hand tools, shear blades, coil springs and high-tensile wire (piano wire).
- 1.0% to 1.2% carbon for sufficient hardness for most metal cutting tools, for example wood drills, screw-cutting taps and screw-cutting dies.
- 1.2% to 1.4% carbon where extreme hardness is required for wood-working tools and knives where a very keen cutting edge is required.

For all of these applications the steel has to undergo heat treatment to enhance its properties. Heat treatment processes are considered later in this chapter.

4.5 Ferrous metals (alloy steels)

These are essentially plain carbon steels to which other metals (*alloying elements*) have been added in sufficient quantities to materially alter the properties of the steel. The most common alloying elements are:

- *Nickel*, to refine the grain and strengthen the steel.
- *Chromium*, to improve the response of the steel to heat treatment; also to improve the corrosion resistance of the steel.
- *Molybdenum*, to reduce temper brittleness during heat treatment, welding, and operation at sustained high temperatures.

- *Manganese*, improves the strength and wear resistance of steels. Steels containing a high percentage of manganese (14%) are highly wear resistant and these steels are used for such applications as bulldozer blades and plough blades.
- *Tungsten* and *cobalt*, improve the ability of a steel to remain hard at high temperatures and are used extensively in cutting tool materials.

Alloy steels are used where great strength is required, corrosion resistance is required, or where the ability to remain hard at high temperatures is required. In this book we only need to consider high-speed steels for cutting tools, and stainless steels where corrosion resistance is required.

4.5.1 High-speed steels

High-speed steels are a group of alloy steels containing metallic elements such as tungsten and cobalt. They are used to make tools suitable for cutting metals. These cutting tools are for use with machine tools where the heat generated by the cutting process would soon soften high carbon steel tools. High-speed steels can operate continuously at 700°C, whereas high carbon steel starts to soften at 220°C. Table 4.3 lists the composition and uses of some typical high-speed steels.

TABLE 4.3 *Typical high-speed steels*

Type of steel	Composition* (%)						Hardness (VNP)	Uses
	C	Cr	W	V	Mo	Co		
18% tungsten	0.68	4.0	19.0	1.5	–	–	800–850	Low-quality alloy, not much used
30% tungsten	0.75	4.7	22.0	1.4	–	–	850–950	General-purpose cutting tools for jobbing work shops
6% cobalt	0.8	5.0	19.0	1.5	0.5	6.0	800–900	Heavy-duty cutting tools
Super HSS 12% cobalt	0.8	5.0	21.0	1.5	0.5	11.5	850–950	Heavy-duty cutting tools for machining high-tensile materials

*C = Carbon, Cr = chromium, W = tungsten, V = vanadium, Mo = molybdenum, Co = cobalt.

4.5.2 Stainless steels

These are also alloy steels. They contain a high proportion of chromium to provide corrosion resistance. Various grades of stainless steel and

TABLE 4.4 *Typical stainless steels*

<i>Type of steel</i>	<i>Composition</i>					<i>Mechanical properties</i>				<i>Heat treatment</i>	<i>Applications</i>
	<i>C</i>	<i>Mn</i>	<i>Cr</i>	<i>Ni</i>	<i>Si</i>	<i>R_m</i>	<i>R_e</i>	<i>A</i>	<i>H_B</i>		
403S17 Ferritic	0.04	0.45	14.0	0.50	0.80	510	340	31	–	Condition soft. Cannot be hardened except by cold work	Soft and ductile; can be used for fabrications, pressings, drawn components, spun components. Domestic utensils
420S45 Martensitic	0.30	1.0	13.0	1.0	0.80	1470	–	–	450	Quench from 950–1000°C. Temper 400–450°C. Temper 150–180°C	Corrosion-resistant springs for food processing and chemical plant. Corrosion-resistant cutlery and edge tools
302S25 Austenitic	0.1	1.0	18.0	8.50	0.80	1670 61	– 278	– 50	534 170	Condition soft solution treatment from 1050°C	18/8 stainless steel widely used for fabrications and domestic and decorative purposes
						896	803	30	–		

their applications are listed in Table 4.4. Because it is ductile and so easily formed 18/8 stainless steel (BS 302S25) is the most widely used alloy.

4.6 Ferrous metals (cast irons)

These are also ferrous metals containing iron and carbon. They do not require the expensive refinement processes of steel making and provide a relatively low cost engineering material that can be easily cast into complex shapes at much lower temperatures than those associated with cast steel. There are four main groups of cast iron, these are:

- Grey cast iron.
- Spheroidal graphite cast iron.
- Malleable cast iron.
- Alloy cast iron.

In this book we are only concerned with *grey cast iron*. Unlike steels, where the carbon content is deliberately restricted so that all of it can combine with the iron, in cast irons there is so much carbon present (about 3%) that not all of it can combine with the iron and some of the carbon is left over. This surplus carbon appears as flakes of graphite between the crystals of metallic iron.

Graphite is the type of carbon that is used to make pencil leads and it is these flakes of graphite that give cast irons their characteristic grey colour when fractured, its 'dirtiness' when machined or filed, and its weakness when it is subjected to a tensile load. The graphite also promotes good machining characteristics by acting as an internal lubricant and causes the chips (swarf) to break up into easily disposable granules. The cavities containing the flakes of graphite have a damping effect upon vibrations – cast iron is *anti-resonant* – and this property makes it particularly suitable for machine tool frames and beds. The graphite also tends to make the slideways self-lubricating.

Most important of all, cast irons have a low melting point compared with steels. Grey cast irons melt between 1130°C and 1250°C depending upon the composition. Cast irons are very fluid when molten which enables them to flow into and fill the most complex of moulds. Also, they expand slightly as they solidify and this enables them to take up the finest detail in the moulds. However, once solidified they contract like any other metal as they cool.

4.7 Abbreviations

Table 4.5 lists some of the abbreviations used for ferrous metals. They may be found on storage racks in the stores and on engineering drawings. Such abbreviations are very imprecise and refer mainly to groups of materials that can vary widely in composition and properties within the

TABLE 4.5 *Abbreviations for ferrous metals*

<i>Abbreviation</i>	<i>Metal</i>
CI	Cast iron (usually 'grey' cast iron)
SGCI	Spheroidal graphite cast iron
MS	Mild steel (low-carbon steel)
BDMS	Bright drawn mild steel
HRPO	Hot-rolled pickled and oiled mild steel
CRCA	Cold-rolled close annealed mild steel
GFS	Ground flat stock (gauge plate)
LCS	Low-carbon steel
SS	Silver steel (centreless ground high-carbon steel)
HSS	High-speed steel
Bright bar	Same as BDMS
Black bar	Hot-rolled steel still coated with scale

group. It is better to specify a material precisely using a British Standard coding.

4.8 British standards for wrought steels

During World War II all wrought steels were standardized in BS 970, and the steels were given EN numbers. The initials EN stood for either *emergency number* or for *economy number*, the exact meaning having become lost in the mists of time. This was a random system of numbering in which EN8 was a medium carbon steel, EN32 a case hardening low carbon steel and EN24 a high tensile nickel chrome alloy steel. Despite the fact that the BSI issued memoranda to all major suppliers and users of wrought steel that the old system should be discontinued as soon as possible after 1972 to avoid confusion, these outdated specifications are still used.

Between 1970 and 1972, BS 970 was reissued using number and letter codes that more accurately described the composition and properties of the steels listed. This code is built up as follows.

The first three symbols are a number code indicating the type of steel.

- 000 to 199 Carbon and carbon manganese steels. The numbers indicate the manganese content $\times 100$.
- 200 to 240 Free cutting steels, with the second and third numbers indicating the sulphur content $\times 100$.
- 250 Silicon valve steels.
- 300 to 499 Stainless steels.
- 500 to 999 Alloy steels.

The fourth symbol is a letter code and is applied as follows.

- A The steel is supplied to a chemical composition determined by chemical analysis of a batch sample.
- H The steel is supplied to a hardenability specification. This is the maximum hardness that can be obtained for a specimen of a specified diameter.
- M The steel is supplied to a mechanical property specification.
- S The material is a stainless steel.

The fifth and sixth symbols are a number code indicating the average carbon content for a given steel. The code is carbon content $\times 100$.

Therefore a steel that is specified as BS 970.040A10 is interpreted as:

- BS 970 indicates the standard being applied.
- 040 lies between 000 and 199 and indicates that we are dealing with a plain carbon steel containing some manganese.
- 040 also indicates that the steel contains 0.40% manganese since $0.40 \times 100 = 040$.
- A indicates that the composition has been determined by batch analysis.
- 10 indicates that the steel contains 0.1% carbon since $0.1 \times 100 = 10$.

This revised BS 970 is currently issued in four parts:

- Part 1 General inspection and testing procedures and specific requirements for carbon, carbon manganese, alloy and stainless steels.
- Part 2 Requirements for steels for manufacture of hot formed springs.
- Part 3 Bright bars for general engineering purposes.
- Part 4 Valve steels.

The revised BS 970 is now being phased out and replaced by a new family of standards covering all aspects of steel making and supply. These range between BS EN 10001 and BS EN 10237 inclusive. The initials EN now indicate that these standards are the English language versions of European standards (EN = European number). These new standards are outside the scope of this book.

4.9 Non-ferrous metals and alloys

Non-ferrous metals and alloys refer to the multitude of metals and alloys that do not contain iron or, if any iron is present, it is only a minute trace. The most widely used non-ferrous metals and alloys are:

- Aluminium and its alloys.
- Copper and its alloys.

- Zinc-based die-casting alloys.
- Titanium and its alloys used in the aerospace engineering including airframe and engine components.

In this book we are only interested in the first two groups.

4.9.1 Aluminium and its alloys

Aluminium is the lightest of the commonly used metals. Its electrical and thermal conductivity properties are very good, being second only to copper. It also has good corrosion resistance and is cheaper than copper. Unfortunately, it is relatively mechanically weak in the pure state and is difficult to solder and weld. Special techniques and materials are required for these processes. Pure aluminium is available as foil, sheet, rod, wire and sections (both drawn and extruded). It is also the basis of a wide range of alloys. These can be classified as:

- Wrought alloys (not heat-treatable).
- Wrought alloys (heat-treatable).
- Casting alloys (not heat-treatable).
- Casting alloys (heat-treatable).

The composition and uses of some typical examples of each group of aluminium alloys are listed in Table 4.6.

4.9.2 Copper and its alloys

Copper has already been introduced as a corrosion resistant metal with excellent electrical and thermal conductivity properties. It is also relatively strong compared with aluminium and very easy to join by soldering or brazing. It is very much heavier than aluminium and also more costly. Copper is available as cold drawn rods, bars, wire and tubes, cold rolled sheet and strip, extruded sections, castings and powder for sintered components. So-called 'pure copper' is available in the following grades.

Cathode copper

This is used for the production of copper alloys. As its name implies, cathode copper is manufactured by an electrolytic refining process.

High conductivity copper

This is better than 99.9% pure and is used for electrical conductors and heat exchangers.

Tough pitch copper

This is a general purpose, commercial grade copper containing some residual copper oxide from the refining process. It is this copper oxide content

TABLE 4.6 *Typical aluminium alloys*

<i>Composition (%)</i>						<i>Category</i>	<i>Applications</i>
<i>Copper</i>	<i>Silicon</i>	<i>Iron</i>	<i>Manganese</i>	<i>Magnesium</i>	<i>Other elements</i>		
0.1 max.	0.5 max.	0.7 max.	0.1 max.	–	–	Wrought Not heat-treatable	Fabricated assemblies. Electrical conductors. Food and brewing processing plant. Architectural decoration
0.15 max.	0.6 max.	0.75 max.	1.0 max.	4.5–5.5	0.5 chromium	Wrought Not heat-treatable	High-strength shipbuilding and engineering products. Good corrosion resistance
1.6	10.0	–	–	–	–	Cast Not heat-treatable	General purpose alloy for moderately stressed pressure die-castings
–	10.0–13.0	–	–	–	–	Cast Not heat-treatable	One of the most widely used alloys. Suitable for sand, gravity and pressure die-castings. Excellent foundry characteristics for large marine, automotive and general engineering castings

(continued overleaf)

TABLE 4.6 (continued)

<i>Composition (%)</i>						<i>Category</i>	<i>Applications</i>
<i>Copper</i>	<i>Silicon</i>	<i>Iron</i>	<i>Manganese</i>	<i>Magnesium</i>	<i>Other elements</i>		
4.2	0.7	0.7	0.7	0.7	0.3 titanium (optional)	Wrought Heat-treatable	Traditional 'Duralumin' general machining alloy. Widely used for stressed components in aircraft and elsewhere
–	0.5	–	–	0.6	–	Wrought Heat-treatable	Corrosion-resistant alloy for lightly stressed components such as glazing bars, window sections and automotive body components
1.8	2.5	1.0	–	0.2	0.15 titanium 1.2 nickel	Cast Heat-treatable	Suitable for sand and gravity die-casting. High rigidity with moderate strength and shock resistance. A general purpose alloy
–	–	–	–	10.5	0.2 titanium	Cast Heat-treatable	A strong, ductile and highly corrosion-resistant alloy used for aircraft and marine castings both large and small

that increases its strength and toughness but reduces its electrical conductivity and ductility. It is suitable for roofing sheets, chemical plant, general presswork, decorative metalwork and applications where special properties are not required.

Phosphorous deoxidized, non-arsenical copper

This is a welding quality copper. Removal of the dissolved oxygen content prevents gassing and porosity. Also the lack of dissolved and combined oxygen improves the ductility and malleability of the metal. It is used in fabrications, castings, cold impact extrusion and severe presswork.

Arsenical tough pitch and phosphorous deoxidized copper

The addition of traces of the metal arsenic improves the strength of the metal at high temperatures. Arsenical coppers are used for boiler and firebox plates, flue tubes and general plumbing.

The main groups of copper-based alloys are:

- High copper content alloys (e.g. cadmium copper, silver copper, etc.).
- Brass alloys (copper and zinc).
- Tin bronze alloys (copper and tin).
- Aluminium bronze alloys (copper and aluminium).
- Cupro-nickel alloys (copper and nickel).

In this book we are interested only in the brass alloys and the tin bronze alloys.

Brass alloys

Brass alloys of copper and zinc tend to give rather weak and porous castings. The brasses depend largely upon hot and/or cold working to consolidate the metal and improve its mechanical properties. The brass alloys can be hardened only by cold working (work hardening). They can be softened by heat treatment (the annealing process). The composition and uses of the more commonly available brass alloys are given in Table 4.7.

Tin bronze alloys

These are alloys of copper and tin together with a *de-oxidizer*. The de-oxidizer is essential to prevent the tin content from oxidizing at high temperatures during casting and hot working. Oxidation is the chemical combination of the tin content with the oxygen in the atmosphere, and it results in the bronze being weakened and becoming hard, brittle and 'scratchy'. Two de-oxidizers are commonly used:

- A small amount of phosphorus in the *phosphor bronze* alloys.
- A small amount of zinc in the *gun metal* alloys.

TABLE 4.7 *Typical brass alloys*

<i>Name</i>	<i>Composition (%)</i>			<i>Applications</i>
	<i>Copper</i>	<i>Zinc</i>	<i>Other elements</i>	
Cartridge brass	70	30	–	Most ductile of the copper–zinc alloys. Widely used in sheet metal pressing for severe deep drawing operations. Originally developed for making cartridge cases, hence its name
Standard brass	65	35	–	Cheaper than cartridge brass and rather less ductile. Suitable for most engineering processes
Basis brass	63	37	–	The cheapest of the cold-working brasses. It lacks ductility and is only capable of withstanding simple forming operations
Muntz metal	60	40	–	Not suitable for cold working, but hot works well. Relatively cheap due to its high zinc content, it is widely used for extrusion and hot-stamping processes
Free-cutting brass	58	39	3% lead	Not suitable for cold working, but excellent for hot working and high-speed machining of low-strength components
Admiralty brass	70	29	1% tin	This is virtually cartridge brass plus a little tin to prevent corrosion in the presence of salt water
Naval brass	62	36	1% tin	This is virtually Muntz metal plus a little tin to prevent corrosion in the presence of salt water

The composition and uses of some typical tin bronze alloys are listed in Table 4.8. Unlike the brasses, which are largely used in the wrought condition (rod, sheet, etc.), only low tin content bronzes can be worked and most bronze components are in the form of castings. The tin bronze alloys are more expensive than the brass alloys but they are stronger and give sound, pressure-tight castings that are widely used for steam and hydraulic valve bodies and mechanisms. They are highly resistant to corrosion.

TABLE 4.8 *Typical tin–bronze alloys*

<i>Name</i>	<i>Composition (%)</i>					<i>Application</i>
	<i>Copper</i>	<i>Zinc</i>	<i>Phosphorus</i>	<i>Tin</i>	<i>Lead</i>	
Low-tin bronze	96	–	0.1–0.25	3.9–3.75	–	This alloy can be severely cold worked to harden it so that it can be used for springs where good elastic properties must be combined with corrosion resistance, fatigues resistance and electrical conductivity, e.g. contact blades

TABLE 4.8 (continued)

Name	Composition (%)					Application
	Copper	Zinc	Phosphorus	Tin	Lead	
Drawn phosphor-bronze	94	–	0.1–0.5	5.9–5.5	–	This alloy is used in the work-hardened condition for turned components requiring strength and corrosion resistance, such as valve spindles
Cast phosphor-bronze	rem.	–	0.03–0.25	10	–	Usually cast into rods and tubes for making bearing bushes and worm wheels. It has excellent anti-friction properties
Admiralty gunmetal	88	2	–	10	–	This alloy is suitable for sand casting where fine-grained, pressure-tight components such as pump and valve bodies are required
Leaded-gunmetal (free-cutting)	85	5	–	5	5	Also known as 'red brass', this alloy is used for the same purposes as standard, Admiralty gunmetal. It is rather less strong but has improved pressure tightness and machine properties
Leaded (plastic) bronze	74	–	–	2	24	This alloy is used for lightly loaded bearings where alignment is difficult. Due to its softness, bearings made from this alloy 'bed in' easily

4.10 Workshop tests for the identification of metals

Materials represent a substantial investment in any manufacturing company. It is essential that all materials are carefully stored so that they are not damaged or allowed to deteriorate before use. Ferrous metals must be stored in a warm, dry environment so that rusting cannot occur. This is particularly the case when storing bright drawn sections and bright rolled sheet. Rusting would quickly destroy the finish and cause such materials to be unfit for use. Materials must also be carefully labelled or coded so that they can be quickly and accurately identified. Mistakes, resulting in the use of the incorrect material, can be very costly through waste. It can also cause serious accidents if a weak metal is used in mistake for a strong one for highly stressed components.

The similarity in appearance between many metals of different physical properties makes it essential that some form of permanent identification should be marked on them, e.g. colour coding. However, mix-ups do occur from time to time and also bar 'ends' are often used up for 'one-off' jobs. Table 4.9 gives some simple workshop tests of identification.

4.11 Non-metals (natural)

Non-metals are widely used in engineering today. Some of the materials occur naturally. For example:

TABLE 4.9 *Workshop identification tests*

<i>These are not foolproof and require some experience</i>				
<i>Metal</i>	<i>Appearance</i>	<i>Hammer cold</i>	<i>Type of chip</i>	<i>'Spark test' on grinding wheel</i>
Mild steel ('black')	Smooth scale with blue/black sheen	Flattens easily	Smooth, curly ribbon-like	Stream of yellow white sparks, varying in length: slightly 'fiery'
Mild steel ('bright')	Smooth, scale-free, silver grey surface	Flattens easily	Smooth, curly ribbon-like	Stream of yellow white sparks, varying in length: slightly 'fiery'
Medium-carbon steel	Smooth scale, black sheen	Fairly difficult to flatten	Chip curls more tightly and discolours light brown	Yellow sparks, shorter than m/s, and finer and more feathery
High-carbon steel	Rougher scale, black	Difficult to flatten	Chip curls even more tightly and discolours dark blue	Sparks less bright, starting near grinding wheel, and more feathery with secondary branching (distinctive acrid smell)
High-speed steel	Rougher scale, black with reddish tint	Very difficult to flatten. Tends to crack easily	Long ribbon-like chip. Distinctive smell. Over-heats tool easily	Faint red streak ending in fork (distinctive acrid smell)
Cast iron	Grey and sandy	Crumbles	Granular, grey in colour	Faint red spark, ending in bushy yellow sparks (distinctive acrid smell)
Copper	Distinctive 'red' colour	Flattens very easily	Ribbon-like, with razor edge	Should not be ground – no sparking
Aluminium	Silvery when polished. Pale grey when oxidized. Very light in weight compared with other metals	Flattens very easily	Ribbon-like chip	Should not be ground – no sparking

- *Rubber* is used for anti-vibration mountings, coolant and compressed air hoses, transmission belts, truck wheel tyres.
- *Glass* is used for spirit level vials (the tube that contains the bubble), lenses for optical instruments.
- *Emery and corundum* (aluminium oxides) are used for abrasive wheels, belts and sheets, and as grinding pastes. Nowadays it is usually produced artificially to control the quality.

- *Wood* for making casting patterns.
 - *Ceramics* for cutting tool tips and electrical insulators.
-

4.12 Non-metals (synthetic)

These are popularly known as *plastics*. When we were considering the properties of materials, a plastic material is said to be one that deforms to a new shape under an applied load and retains its new shape when the load is removed. Yet, the range of synthetic materials we call plastics are often tough and leathery, or hard and brittle, or elastic. They are called plastics because, during the moulding operation by which they are formed, they are reduced to a plastic condition by heating them to about twice the temperature of boiling water.

There are many families of ‘plastic’ materials with widely differing properties. However, they all have certain properties in common.

- *Electrical insulation*. All plastic materials are, to a greater or lesser extent, good electrical insulators (they are also good heat insulators). However, their usefulness as insulators is limited by their inability to withstand high temperatures and their relative softness compared with ceramics. They are mainly used for insulating wires and cables and for moulded switch gear and instrument components and cases.
- *Strength/weight ratio*. Plastic materials vary considerably in strength. All plastics are much less dense than metals and this results in a favourable strength/weight ratio. The high strength plastics and reinforced plastics compare favourably with the aluminium alloys and are often used for stressed components in aircraft construction.
- *Degradation*. Plastics do not corrode like metals. They are all inert to most inorganic chemicals. They can be used in environments that are chemically hostile to even the most corrosion resistant metals. They are superior to natural rubber in their resistance to attack by oils and greases. However, all plastics degrade at high temperatures and many are degraded by the ultraviolet content of sunlight. Plastics that have to be exposed to sunlight (window frames and roof guttering) usually contain a pigment that filters out the ultraviolet rays. Some thermoplastics can be dissolved by suitable solvents.
- *Safety*. Plastics can give off very dangerous toxic fumes when heated. Note the number of people who have died from inhaling the smoke from plastic furniture padding in house fires! Solvents used in the processing of plastics are often highly toxic and should not be inhaled but used in well-ventilated surroundings. Make sure you know the likely dangers before starting work on plastic materials and always follow the safe working practices laid down by the safety management.

Plastic materials can be grouped into two distinct families. These are the *thermosetting plastics* and the *thermoplastics*. Typical examples of each of these families will now be considered. Note that thermosetting plastics are often referred to simply as ‘thermosets’.

4.12.1 Thermosetting plastics

These undergo a chemical change called ‘curing’ during hot moulding process. Once this chemical change has taken place, the plastic material from which the moulding is made can never again be softened and reduced to a plastic condition by reheating.

Thermosetting resins are unsuitable for use by themselves and they are usually mixed with other substances (additives) to improve their mechanical properties, improve their moulding properties, make them more economical to use, and provide the required colour for the finished product. A typical moulding material could consist of:

- Resin 38% by weight
- Filler 58% by weight
- Pigment 3% by weight
- Mould release agent 0.5% by weight
- Catalyst 0.3% by weight
- Accelerator 0.2% by weight

The pigment gives colour to the finished product. The mould release agent stops the moulding sticking to the mould. It also acts as an internal lubricant and helps the plasticized material to flow to the shape of the mould. The catalyst promotes the curing process and the accelerator speeds up the curing process and reduces the time the moulds have to be kept closed, thus improving productivity.

Fillers are much cheaper than the resin itself and this is important in keeping down the cost of the moulding. Fillers also have a considerable influence on the properties of the mouldings produced from a given thermosetting resin. They improve the impact strength (toughness) and reduce shrinkage during moulding. Typical fillers are:

- *Shredded paper* and *shredded cloth* give good strength and reasonable electrical insulation properties at a low cost.
- *Mica granules* give good strength and heat resistance (asbestos is no longer used).
- *Aluminium powder* gives good mechanical strength and wear resistance.
- *Wood flour (fine sawdust)* and *calcium carbonate (ground limestone)* provide high bulk at a very low cost but with relatively low strength.
- *Glass fibre (chopped)* gives good strength and excellent electrical insulation properties.

Some typical examples of thermosetting plastics and their uses are given in Table 4.10.

4.12.2 Thermoplastics

These can be softened as often as they are reheated. They are not so rigid as the thermosetting plastics but they tend to be tougher. Additives (other

TABLE 4.10 *Some typical thermosetting plastic materials*

<i>Material</i>	<i>Characteristics</i>
Phenolic resins and powders	These are used for dark-coloured parts because the basic resin tends to become discoloured. These are heat-curing materials
Amino (containing nitrogen) resins and powders	These are colourless and can be coloured if required; they can be strengthened by using paper-pulp fillers, and used in thin sections
Polyester resins	Polyester chains can be cross-linked by using a monomer such as styrene; these resins are used in the production of glass-fibre laminates
Epoxy resins	These are also used in the production of glass-fibre laminates

TABLE 4.11 *Some typical thermoplastic materials*

<i>Type</i>	<i>Material</i>	<i>Characteristics</i>
Cellulose plastics	Nitrocellulose	Materials of the 'celluloid' type are tough and water resistant. They are available in all forms except moulding powders. They cannot be moulded because of their flammability
	Cellulose acetate	This is much less flammable than the above. It is used for tool handles and electrical goods
Vinyl plastics	Polythene	This is a simple material that is weak, easy to mould, and has good electrical properties. It is used for insulation and for packaging
	Polypropylene	This is rather more complicated than polythene and has better strength
	Polystyrene	Polystyrene is cheap, and can be easily moulded. It has a good strength but it is rigid and brittle and crazes and yellows with age
	Polyvinyl chloride (PVC)	This is tough, rubbery, and almost non-inflammable. It is cheap and can be easily manipulated: it has good electrical properties
Acrylics (made from an acrylic acid)	Polymethyl methacrylate	Materials of the 'Perspex' type have excellent light transmission, are tough and non-splintering, and can be easily bent and shaped
Polyamides (short carbon chains that are connected by amide groups – NHCO)	Nylon	This is used as a fibre or as a wax-like moulding material. It is fluid at moulding temperature, tough, and has a low coefficient of friction
Fluorine plastics	Polytetrafluoroethylene (PTFE)	Is a wax-like moulding material; it has an extremely low coefficient of friction. It is very expensive
Polyesters (when an alcohol combines with an acid, an 'ester' is produced)	Polyethylene terephthalate	This is available as a film or as 'Terylene'. The film is an excellent electrical insulator

than a colourant and an internal lubricant) are not normally used with thermoplastics. Some typical examples of thermoplastics and their uses are given in Table 4.11.

4.13 Forms of supply There is an almost unlimited range to the forms of supply in which engineering materials can be supplied to a manufacturer or to a fabricator. Figure 4.8 shows some of these forms of supply.

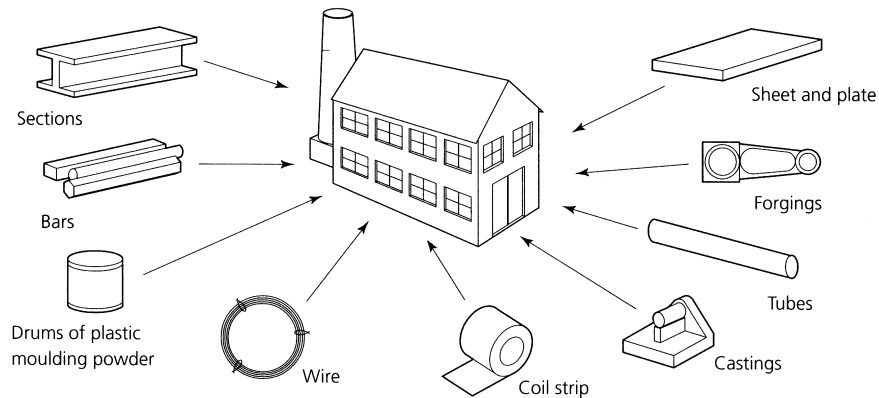


Figure 4.8 *Forms of supply*

- *Sections* such as steel angles, channel sections, H-section beams and joists and T-sections in a wide range of sizes and lengths. They are usually hot-rolled with a heavily scaled finish. Such sections are mostly used in the steel fabrication and civil engineering and construction industries. Bright-drawn steel angle sections are available in the smallest sizes. Non-ferrous metal sections are normally extruded to close tolerances and have a bright finish. Both standard sections and sections to customers' own requirements are made this way. The sizes available are very much smaller than for steel sections.
- *Bars* may be 'flats', which are available in rectangular sections, 'squares', or 'rounds', which have a cylindrical section and this term applies to the larger sizes. In the smaller size they are usually referred to as 'rods'. They are available in hot-rolled (black) or cold-drawn (bright) finishes. Hexagon section bars for making nuts and bolts are always cold-drawn.
- *Plastics* may be supplied in powder or granular form for moulding into various shapes. They may also be supplied semi-finished in rounds, flats, squares, tubes, and sheet. They may also come in sections to manufacturers' own requirements such as curtain rails and insulation blocks ready for cutting off to length. Reinforced plastics such as 'Tufnol' are also available in standard sections and mouldings.
- *Wire* is available bright-drawn or hot-rolled depending upon its size and the use to which it is going to be put. Bright-drawn, high carbon

steel wire (piano wire) is used for making springs. Copper wire is used for electrical conductors. The smaller the diameter of any wire the greater the length that can be made in one piece.

- *Coil strip* is used for cold stamping and pressing where continuous automatic feed to the presses is required. It is available in a range of thicknesses and finishes. Steel strip is available in such finishes as bright-rolled (BR), hot-rolled, pickled and oiled (HRPO) and cold-rolled, closed-annealed (CRCA). It can be sheared on continuous rotary shears to the customer's specification where accurate control of the width is required. Alternatively it can be left with a 'mill-edge' where the flats' surfaces are bright-rolled and the edges are left rounded and in the hot-rolled state. Non-ferrous strip is usually bright-rolled and sheared to width. The rolling process tends to work harden the strip which is sold in various 'tempers' according to the amount of cold working it has received since annealing. For example, dead-soft, soft, quarter-hard, half-hard, etc.
- *Castings* can be made in most metals and alloys but the moulding process will vary depending upon the type of metal, the size of the casting, the accuracy of the casting and the quantities involved. There are no 'standard' castings. They are made to the customer's own patterns or, in the case of die-casting, in the customer's own dies.
- *Tubes and pipes* can be made in ferrous and non-ferrous metals and alloys and in plastic. Tubes refer to the smaller sizes and pipes to the larger sizes. Steel pipes may be cold-drawn or hot-drawn without seams for the highest pressures. They may also be rolled from strip with a butt-welded seam running along the length of the pipe or tube where lower pressures are involved, or they are used only for sheathing (electrical conduit is made like this). Plastic tube may be rigid or flexible.
- *Forgings* may be manufactured by forming the red-hot metal with standard tools by a 'blacksmith' when only small quantities are required. The size may range from horseshoes, farm implements, and decorative wrought-iron work made by hand, to turbine shafts and ships' propeller shafts forged under huge hydraulic presses. Where large quantities of forging of the same type are required, these are drop-forged. The red-hot steel is forged in dies which impart the finished shape to the forging. Light alloy (aluminium alloy) forgings are used by the aircraft industry. Because of the low melting temperature of such alloys compared with steel, they have to be forged at a lower temperature. This requires a greater forging pressure and care must be taken that cracking does not occur.
- *Sheet and plate* starts off as very wide coiled strip and is then passed through a series of rollers to flatten it. It is sheared to length by 'flying shears' that cut it whilst the flattened strip is moving. The terminology is somewhat vague and depends upon the metal thickness. Generally, 'sheet' can be worked with hand tools and ranges from foil (very thin sheet) to about 1.5 mm thick. Then comes 'thin plate' up to about 6 mm thick. After that it becomes thick plate. Both thin and

thick plate have to be cut and formed using power driven tools. Sheet is available in both cold- and hot-rolled finishes, whereas plate is available only as hot-rolled. For the sizes of any standard metallic products, see BS 6722: 1986 (amended 1992).

4.14 Heat treatment processes (introduction)

Heat treatment processes as a means of modifying the properties of metals have already been mentioned earlier in this chapter. Table 4.12 summarizes and defines the more common heat treatment processes. Because of the wide range of non-ferrous metals and alloys that exist, the heat treatment processes for non-ferrous metals vary widely and all such processes are quite different to the processes used for the heat treatment of plain carbon steels. However, some of the more important processes for the heat treatment of copper-based and aluminium-based alloys will be included in this chapter.

TABLE 4.12 *Heat treatment definitions*

<i>Term</i>	<i>Meaning</i>
Annealed	The condition of a metal that has been heated above a specified temperature, depending upon its composition, and then cooled down in the furnace itself or by burying it in ashes or lime. This annealing process makes the metal very soft and ductile. Annealing usually precedes flow-forming operations such as sheet metal pressing and wire and tube drawing
Normalised	The condition of a metal that has been heated above a specified temperature, depending upon its composition, and then cooled down in free air. Although the cooling is slow, it is not as slow as for annealing so the metal is less soft and ductile. This condition is not suitable for flow forming but more suitable for machining. Normalizing is often used to stress relieve castings and forgings after rough machining
Quench hardened	The condition of a metal that has been heated above a specified temperature, depending upon its composition, and then cooled down very rapidly by immersing it in cold water or cold oil. Rapid cooling is called quenching and the water or oil is called the quenching bath . This rapid cooling from elevated temperatures makes the metal very hard. Only medium- and high-carbon steels can be hardened in this way
Tempered	Quench-hardened steels are brittle as well as hard. To make them suitable for cutting tools they have to be reheated to a specified temperature between 200 and 300°C and again quenched. This makes them slightly less hard but very much tougher. Metals in this condition are said to be <i>tempered</i>

4.15 Heat treatment processes (safety)

General safety was introduced in Chapter 1. However, heat treatment can involve large pieces of metal at high temperatures and powerful furnaces. Therefore it is now necessary to consider some safety practices relating specifically to heat treatment processes, before discussing the processes involved.

4.15.1 Protective clothing

Ordinary workshop overalls do not offer sufficient protection alone. Many are made from flammable cloths. Further, synthetic cloths made from nylon or rayon fibres, or mixtures of natural and synthetic fibres, can melt and stick to your skin at the temperatures met with in heat treatment. This worsens any burn you may receive. Overalls used in heat treatment shops should be made from a flame resistant or a flame retardant material and be labelled accordingly. In addition a leather apron should be worn to prevent your overalls coming into contact with hot workpieces and hot equipment.

4.15.2 Gloves

Gloves should be worn to protect your hands. These should be made from leather or other heat resistant materials and should have gauntlets to protect your wrists and the ends of the sleeves of your overalls. Leather gloves offer protection up to 350°C.

4.15.3 Headwear, goggles and visors

Headwear, goggles and visors, such as those described in Chapter 1, should be worn when there is any chance of danger to your eyes, the skin of your face, and your hair and scalp. Such dangers can come from:

- splashes from the molten salts when using salt bath furnaces;
- splashes from hot liquids when quenching;
- the accidental ignition of oil quenching baths due to overheating;
- radiated heat from large furnaces when their doors are opened;
- accidental 'flashbacks' when lighting up furnaces.

4.15.4 Safety shoes and boots

The safety shoes and boots as recommended for wearing in workshops were introduced in Chapter 1. They are also most suitable for use in heat treatment shops. They not only protect you from cuts and crushing from heavy falling objects, being made of strong leather they also protect against burns from hot objects. Your first instinctive reaction to accidentally picking up anything hot is to let go quickly and drop it. This is when the toe protection of industrial safety shoes earns its keep. In addition, it is advisable that leather spats are worn. These protect your lower legs and ankles from splashes of molten salts or spillage of hot quenching fluids. Spats are particularly important if you wear safety shoes rather than safety boots.

4.15.5 Safety equipment

Heat treatment can cover a whole range of processes and sizes of workpieces from hardening a simple tool made from a piece of silver steel

using a gas blowpipe to heat it and a bucket of cold water to quench it in, to the production treatment of large components. They all have the same basic problem. That is, very hot metal has to be handled. There are very many methods of handling hot workpieces depending upon their size, the quantity involved, type of furnace being used and the process. Here are a few examples of how the hot components can be handled:

- Small components can be handled individually using tongs.
- Quantities of small components can be handled on trays or in baskets. These trays and baskets are usually made from a heat resistant metal such as the nickel alloy called *inconel*. The baskets can be handled in or out of salt bath furnaces and in or out of the quenching bath using a hoist.
- Large components and trays of smaller components can be handled in or out of muffle type furnaces on rollers. Long handled hooks and rakes are used to push the components into the furnace or to pull them out when hot.

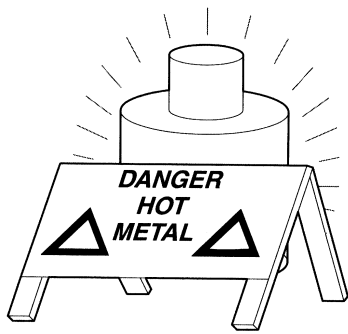


Figure 4.9 *Safety notices must be placed by hot objects*

4.15.6 Safety notices

Whilst metal is red-hot it is obviously in a dangerous condition. However, most accidents occur when the metal has cooled down to just below red heat. Although no longer glowing, it is still hot enough to cause serious burns and to start fires if flammable substances come into contact with it. Hot workpieces must never be stored in gangways and warning notices must be used as shown in Fig. 4.9. Such notices must satisfy the legal requirements of the Health and Safety Executive.

4.15.7 Fire

Quenching baths using a quenching oil must have an airtight lid. In the event of the oil overheating and igniting, the lid can be closed and the lack of air puts the fire out. Quenching tanks should always have sufficient reserve capacity so that the oil does not overheat. If the oil is allowed to overheat:

- The oil will not cool the work quickly enough to harden it.
- The oil may catch fire.

Only quenching oil with a high flash point and freedom from fuming should be used. *Lubricating oil must never be used.* A suitable fire extinguisher, or several fire extinguishers if a large quenching tank is used, should be positioned conveniently near to the bath in case of an emergency. The type of extinguisher should be suitable for use on oil fires.

Furnaces and blowpipes must not be lit or closed down without proper instruction and permission. Incorrect setting of the controls and incorrect lighting-up procedures can lead to serious explosions. All personnel working in heat treatment shops must be alert to the possibility of fires.

- They must be conversant with and trained in the correct fire drill.
 - Fire drills must be practised regularly to ensure everyone knows what to do.
 - They must know where the nearest alarm is and how to operate it.
 - They must know where the nearest telephone is and how to summon the fire brigade.
 - They must know where the exits are and how to evacuate the premises. Fire exits must be left clear of obstructions.
 - They must know where to assemble so that a roll-call can be taken.
 - They must know the correct fire-fighting procedures so that the fire can be contained until the professional brigade arrives, only providing this can be done safely.
 - When an outbreak of fire is discovered the correct fire drill must be put into action immediately.
-

4.16 The heat treatment of plain carbon steels

Plain carbon steels are subjected to heat treatment processes for the following reasons:

- To improve the properties of the material as a whole, for example by imparting hardness to prevent wear or softness and grain refinement to improve its machining properties.
- To remove undesirable properties acquired during previous processing – for example, hardness and brittleness imparted by cold working.

The heat treatment processes we are now going to consider in order to modify the properties of plain carbon steels are:

- Through (quench) hardening.
- Tempering.
- Annealing.
- Normalizing.
- Case hardening.

4.16.1 Through-hardening

Basically the process by which we ‘through-harden’ (also referred to as *quench hardening*) consists of heating a suitable steel to a critical temperature that is dependent upon the carbon content of the steel and

cooling it quickly (quenching it) in water or quenching oil. The hardness attained will depend upon:

- The carbon content of the steel (the higher the carbon content the harder the steel).
- The rate of cooling (the faster the cooling the harder the steel).

For example, to harden a chisel made from 8% carbon steel, the temperature to which the steel is heated should be between 800°C and 830°C. That is, the steel should glow ‘cherry red’ in colour. It is then quenched by cooling it in cold water. Any increase in temperature will make no difference to the hardness of the chisel. It will only result in ‘grain growth’ and weakening of the steel. Grain growth means that the hotter the steel becomes and the longer it is kept at excessively high temperatures the bigger the grains in the metal will grow by merging together.

As previously stated, the steel has to be heated to within a critical temperature range if it is to be correctly hardened. The temperature range for hardening plain carbon steels is shown in Fig. 4.10.

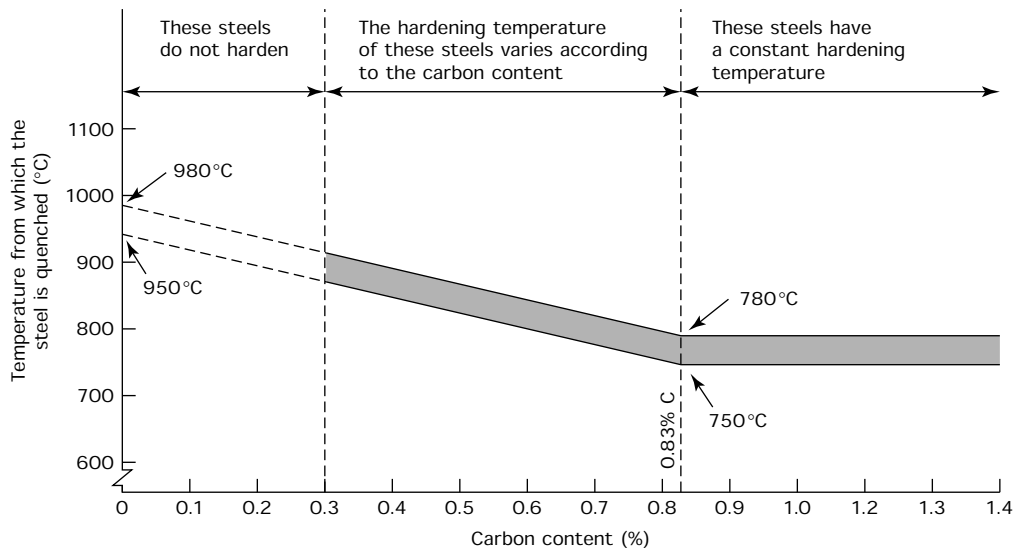


Figure 4.10 *Hardening temperatures for plain carbon steels*

Figure 4.10 shows that the hardening temperatures for plain carbon steels lie in a narrow band depending upon the carbon content of the steel. If the hardening temperature for any given steel is not achieved, it will not harden. If it is exceeded no increase in hardness is achieved but grain growth will occur and the steel will be weakened.

It has already been stated that the more quickly a component is cooled the harder it becomes for any given carbon content. However, some care is required because the faster you cool the workpiece, the more likely it

is to crack and distort. Therefore the workpiece should never be cooled more quickly than is required to give the desired degree of hardness (*critical cooling rate*). The most common substances used for quenching (*quenching media*) are:

- *Brine* (a solution of sodium chloride and water) is the most rapid quenching bath – it will give the greatest hardness and is the most likely to cause cracking.
- *Water* is less severe and is the most widely used quenching bath for plain carbon steels.
- *Oil* is the least severe of the liquid quenching media. Only plain carbon steels of the highest carbon content will harden in oil, and then only in relatively small sections. Oil quenching is mostly used with alloy die steels and tool steels.
- *Air blast* is the least severe of any of the quenching media used. It can be applied only to heavily alloyed steels of small section such as high-speed steel tool bits.

Table 4.13 summarizes the effect of carbon content and rate of cooling for a range of plain carbon steels.

TABLE 4.13 *Effect of carbon content and rate of cooling on hardness*

<i>Type of steel</i>	<i>Carbon content (%)</i>	<i>Effect of heating and quenching (rapid cooling)</i>
Low carbon	Below 0.25	Negligible
Medium carbon	0.3–0.5	Becomes tougher
	0.5–0.9	Becomes hard
High carbon	0.9–1.3	Becomes very hard

<i>Carbon content (%)</i>	<i>Quenching bath</i>	<i>Required treatment</i>
0.30–0.50	Oil	Toughening
0.50–0.90	Oil	Toughening
0.50–0.90	Water	Hardening
0.90–1.30	Water	Hardening

Notes:

1. Below 0.5% carbon content, steels are not hardened as cutting tools, so water hardening has not been included.
2. Above 0.9% carbon content, any attempt to harden the steel in water could lead to cracking.

4.16.2 Quenching, distortion and cracking

Quenching and distortion

When quenching hot metal, some thought must be given to the way the work is lowered into the bath to avoid distortion and to get the most

effective quenching. For example, when hardening a chisel, the shank of the chisel is held with tongs and the chisel is dipped vertically into the quenching bath.

- This results in the cutting end of the steel entering the bath first and attaining maximum hardness whilst the quenching medium is at its minimum temperature.
- The shank is masked to some extent by the tongs and this results in reduced hardness. This does not matter in this example as we want the shank to be tough rather than hard so that it does not shatter when struck with a hammer.
- The chisel should be stirred around in the bath so that it is constantly coming into contact with fresh and cold water. It also prevents steam pockets being generated round the chisel that would slow up the cooling rate and prevent maximum hardness being achieved.
- Dipping a long slender workpiece like a chisel vertically into the bath prevents distortion. This is shown in Fig. 4.11. This figure also shows

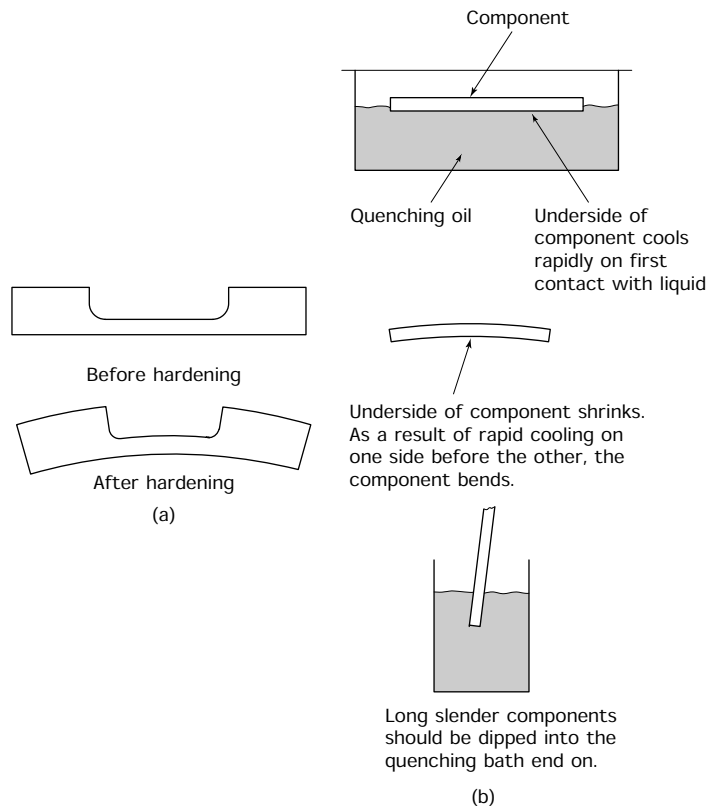


Figure 4.11 *Causes of distortion: (a) distortion caused by an unbalanced shape being hardened; (b) how to quench long, slender components to avoid distortion*

what happens if the component is quenched flat and also how the shape of the component itself can cause uneven cooling and distortion.

Cracking

Figure 4.12 shows some typical causes of cracking occurring during and as a result of heat treatment. Careful design and the correct selection of materials can result in fewer problems in the hardening shop.

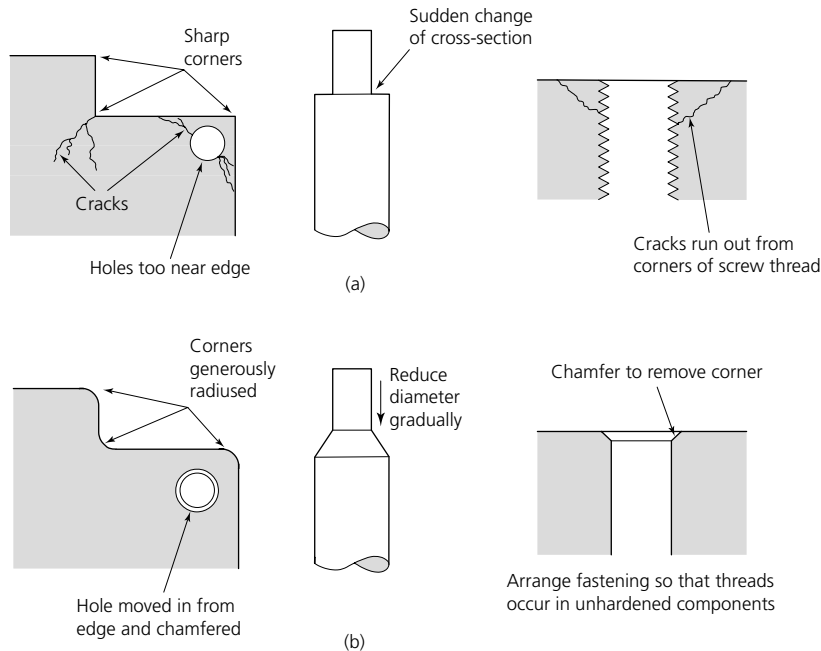


Figure 4.12 Causes of cracking: (a) incorrect engineering that promotes cracking; (b) correct engineering to reduce cracking

- Avoid sharp corners and sudden changes of section.
- Do not position holes, slots and other features near the edge of the workpiece.
- Do not include screw threads in a hardened component. Apart from the chance of cracking occurring, once hardened you cannot run a die down the thread to ease it if it has become distorted during the hardening process.
- For complex shapes, which are always liable to cracking and distortion during hardening, always use an alloy steel that has been formulated so that minimum distortion and shrinkage (movement) will occur during heat treatment. Such steels are oil or air hardened and this also reduces the chance of cracking.

4.16.3 Tempering

When you heat and quench a plain carbon steel as described previously, you not only harden the steel, you also make it *very brittle*. In this condition it is unsuitable for immediate use. For instance, a chisel would shatter if you hit it with a hammer. After hardening we have to carry out another process known as *tempering*. This greatly reduces the brittleness and increases the toughness. However, the tempering process also reduces the hardness to some extent.

Tempering consists of reheating the hardened steel workpiece to a suitable temperature and again quenching it in oil or water. The tempering temperature to which the workpiece is reheated depends only upon the use to which the workpiece is going to be put. Table 4.14 lists some suitable temperatures for tempering components made from plain carbon steels.

TABLE 4.14 *Tempering temperatures*

<i>Component</i>	<i>Temper colour</i>	<i>Temperature (°C)</i>
Edge tools	Pale straw	220
Turning tools	Medium straw	230
Twist drills	Dark straw	240
Taps	Brown	250
Press tools	Brownish-purple	260
Cold chisels	Purple	280
Springs	Blue	300
Toughening (crankshafts)	–	450–600

In a workshop, the tempering temperature is usually judged by the ‘temper colour’ of the oxide film that forms on the surface of the workpiece. After hardening, the surface of the workpiece is polished so that the colour of the oxide film can be clearly seen. Figure 4.13 shows a chisel being tempered. The chisel is not uniformly heated. As shown, the shank is heated in the flame and the temper colours are allowed to ‘run down’ the chisel until the cutting edge reaches the required colour. When the cutting edge is the required temper colour, the chisel is immediately

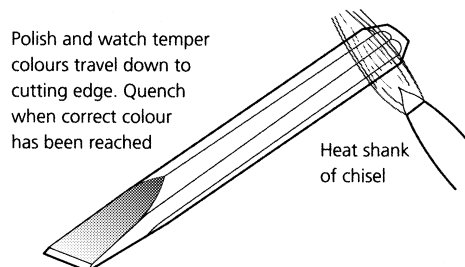


Figure 4.13 *Tempering a cold chisel*

‘dipped’ vertically into the quenching bath again. This gives the cutting edge the correct temper but leaves the shank softer and tougher so that it can withstand being struck with a hammer.

Complex and large components and batches of components should be tempered in a furnace with atmosphere and temperature control to ensure consistent results.

4.16.4 Annealing

Annealing processes are used to soften steels that are already hard. This hardness may be imparted in two ways.

- *Quench hardening*. This has previously been described in Section 4.15.
- *Work hardening*. This occurs when the metal has been cold worked (see Section 4.2.5). It becomes hard and brittle at the point where cold working occurs as this causes the grain structure to deform. For example, if a strip of metal is held in a vice, bending the metal back and forth causes it to work harden at the point of bending. It will eventually become sufficiently hard and brittle to break off at that point.

Full annealing

The temperatures for full annealing are the same as for hardening. To *anneal* (soften the workpiece), you allow the hot metal to cool down as slowly as possible. Small components can be buried in crushed limestone or in ashes. Larger components and batches of smaller components will have been heated in furnaces. When the correct temperature has been reached, the component is ‘soaked’ at this temperature so that the temperature becomes uniform throughout its mass. The furnace is then shut down, the flue dampers are closed and the furnace is sealed so that it cools down as slowly as possible with the work inside it.

Although such slow cooling results in some grain growth and weakening of the metal, it will impart maximum ductility. This results in the metal being in the correct condition for cold forming. However, because of its extreme softness and grain growth the metal will tend to tear and leave a poor surface finish if it is machined. Components to be machined should be *normalized* as described in Section 4.16.5.

Stress-relief annealing

This process is reserved for steels with a carbon content below 0.4%. Such steels will not satisfactorily quench harden but, as they are relatively ductile, they will be frequently cold worked and become work hardened. Since the grain structure will have become severely distorted by the cold working, the crystals will begin to reform and the metal will begin to soften (theoretically) at 500°C. In practice, the metal is rarely so severely stressed as to trigger *recrystallization* at such a low temperature. Stress-relief annealing is usually carried out between 630°C and 700°C to speed

up the process and prevent excessive grain growth. Stress-relief annealing is also known as:

- *Process annealing* since the work hardening of the metal results from cold-working (forming) processes.
- *Inter-stage annealing* since the process is often carried out between the stages of a process when extensive cold working is required. For example, when deep drawing sheet metal in a press.

The degree of stress-relief annealing and the rate of cooling will depend not only upon the previous processing the steel received before annealing, but also upon the processing it is to receive *after* annealing. If further cold working is to take place, the maximum softness and ductility is required. This is achieved by prolonged heating and very slow cooling to encourage grain growth. However, if grain refinement, strength and toughness are more important, then heating and cooling should be more rapid.

4.16.5 Normalizing

Plain carbon steels are normalized by heating them to the temperatures shown in Fig. 4.14. This time we want a finer grain structure in the steel. To achieve this, we have to heat the metal up more quickly and cool it more quickly. The workpiece is taken out of the furnace when its normalizing temperature has been achieved and allowed to cool down in the free air of the heat treatment shop. The air should be able to circulate freely round the workpiece. However, the workpiece must be sited so that it is free from cold draughts. Warning notices that the steel is dangerously hot must be placed around it.

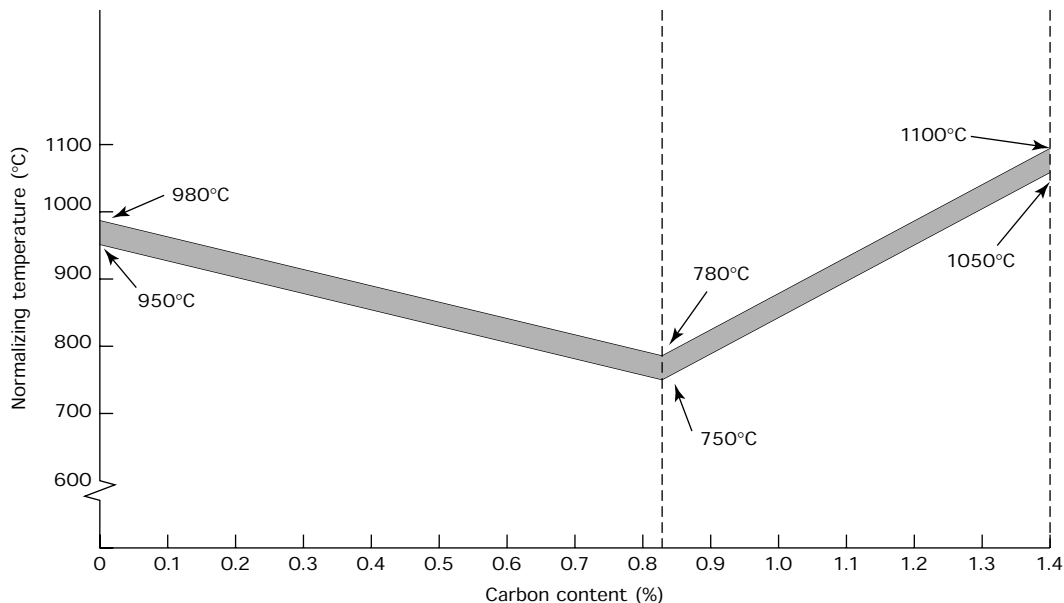


Figure 4.14 *Normalizing temperatures for plain carbon steels*

Castings and forgings are produced by high temperature processes. As they cool down and shrink they often develop high internal stresses. Machining tends to partially release these stresses and over a period of time the machined components 'move' or distort and become inaccurate. At one time, large castings and forgings were rough machined and left out of doors to 'weather' over a period of a year or more. The continual changes in temperature released all the stresses and the components became 'stabilized' ready for finish machining. No further movement then took place.

Keeping such a large amount of valuable stock tied up over a long period of time is no longer economically viable and weathering has given way to *normalizing*. The normalizing process is now frequently used for stress relieving between the rough machining of castings and forgings and the finish machining of such workpieces. This is done to stabilize such workpieces and to avoid 'movement' or distortion subsequent to machining. When normalizing is used for the stabilization of castings and forgings, it is sometimes referred to as 'artificial weathering'.

4.16.6 Case hardening

Often, components need to be hard and wear resistant on the surface, yet have a tough and strong core to resist shock loads. These two properties do not normally exist in a single steel but are achieved by a process called *case hardening*. This is a process by which carbon is added to the surface layers of low carbon steels or low alloy steels to a carefully regulated depth. This addition of carbon is called *carburizing*. After carburizing the component is put through successive heat treatment processes to harden the case and refine the core. This process has two distinct steps as shown in Fig. 4.15. First, the workpiece is heated to between 900°C and 950°C in contact with the carburizing compound until the additional carbon has

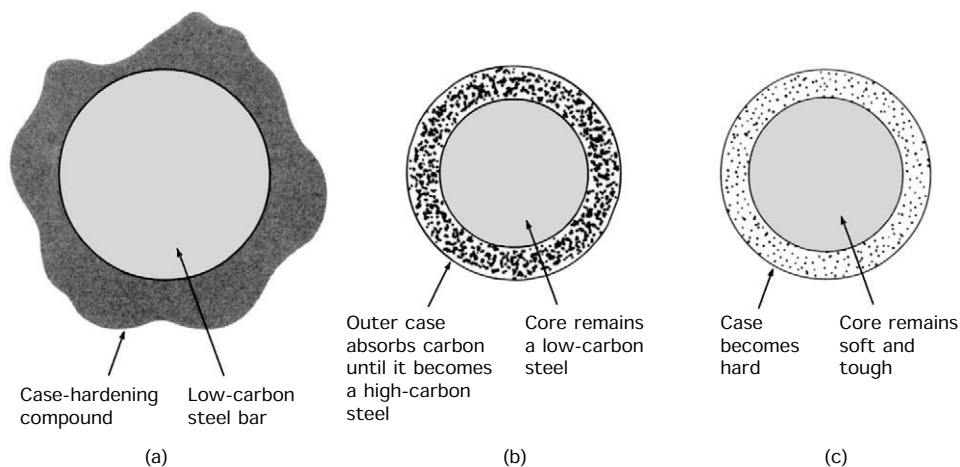


Figure 4.15 Case hardening: (a) carburizing; (b) after carburizing; (c) after quenching a component from a temperature above 780°C

been absorbed to the required depth. Second, the workpiece is removed from the carburizing compound, reheated to between 780°C and 820°C and dipped off (quenched) in cold water.

Carburizing

This depends upon the fact that very low carbon (0.1%) steels will absorb carbon when heated to between 900°C and 950°C. Various carbonaceous materials are used in the carburizing process.

- *Solid media* such as bone charcoal or charred leather, together with an energizer such as sodium and/or barium carbonate. The energizer makes up to 40% of the total composition.
- *Molten salts* such as sodium cyanide, together with sodium carbonate and/or barium carbonate and sodium or barium chloride. Since cyanide is a deadly poison such salts must be handled with great care and the cyanide makes up only between 20 and 50% of the total. Stringent safety precautions must be taken in its use. The components to be carburized are immersed in the molten salts.
- *Gaseous media* based upon natural gas (methane) are increasingly used. Methane is a hydrocarbon gas containing organic carbon compounds that are readily absorbed into the steel. The methane gas is frequently enriched by the vapours that are given off when mineral oils are 'cracked' by heating them in contact with the metal platinum which acts as a catalyst.

It is a common fallacy that carburizing hardens the steel. *It does not*, it adds carbon only to the surface of the steel and leaves the steel in a fully annealed (soft) condition. It is the subsequent heat treatment that hardens the steel.

Superficial hardening

This produces a shallow case on simple components as shown in Fig. 4.16.

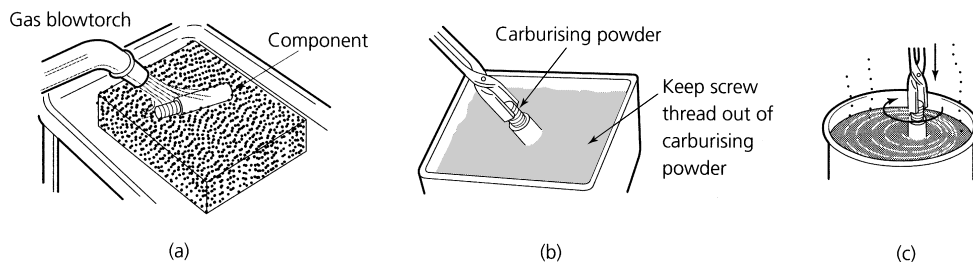


Figure 4.16 *Superficial hardening: (a) heat to bright red in brazing hearth; (b) plunge red-hot component into carburising powder (repeat to give desired depth of case); (c) reheat to cherry red and quench in water*

- The component is raised to red heat using a gas torch and brazing hearth.
- The red-hot component is then plunged into a case-hardening powder. This consists of carbon rich compounds plus an energizer as previously described.
- The component absorbs the powder onto its surface. This ‘carburizes’ the surface of the metal and increases its carbon content.
- The heating and dipping can be repeated several times to increase the depth of carbon infusion.
- Finally, the component is again heated to red heat and plunged immediately into cold water. If the case-hardening powder has done its job, there should be a loud ‘crack’ and any surplus powder breaks away from the surface of the metal.
- The surface of the metal should now have a mottled appearance and it should be hard. The component is now case hardened.
- Because this technique results in only a fairly shallow case, it is referred to as ‘superficial hardening’. The case is not deep enough for finishing by grinding processes, although polishing is permissible.
- Bright-drawn steels do not absorb carbon readily unless the drawn surface is removed by machining. Wherever possible use a case-hardening quality steel which is formulated and processed to suit this treatment.

Deep case hardening

Where a deep case is required so that components can be finished by grinding (e.g. surface grinding or cylindrical grinding) the following procedure is required.

- The component is ‘pack-carburized’ by burying it in the carburizing compound in a steel box, sealed with an airtight lid.
- The box is heated in a furnace for several hours depending upon the depth of case required. The carburizing temperature is about 950°C as shown in Fig. 4.17.
- The box is removed from the furnace and allowed to cool down. The component is removed from the box and cleaned so as to remove any residual powder from its surface.
- The component will be soft and have a coarse grain structure because of the long time for which it has been heated at a high temperature, and its subsequent slow cooling.
- The core of the component will have a carbon content of less than 0.3%. The low carbon steel core of the component is toughened by refining its grain. To do this, the component is heated to 870°C as shown at A in Fig. 4.17 and then quenched in oil.

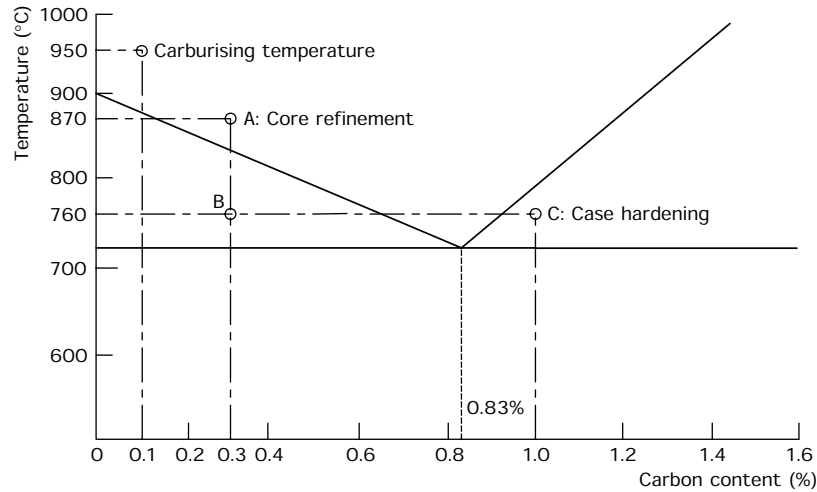


Figure 4.17 *Case-hardening temperatures*

- Since this temperature is well below the carburizing temperature which caused the grain growth and because of the rapid cooling the core will now have a fine grain.
- This rapid cooling will also have the effect of hardening the case. Unfortunately the case will have a coarse grain since it was heated to above its correct hardening temperature as shown at B in Fig. 4.17.
- To refine the grain of the case and reharden it, the component is heated to 760°C, as shown at C in Fig. 4.17, and quenched in water. This is the correct hardening procedure for a 1.0% carbon steel which is what the surface of the component has become. This temperature is too low to affect the fine grain of the core.
- Finally the component can be tempered if required.

Localized case hardening

It is often undesirable to case harden a component all over. For example, it is undesirable to case harden screw threads. Not only would they be extremely brittle, but any distortion occurring during carburizing and hardening could be corrected only by expensive thread grinding operations. Various means are available for avoiding local infusion of carbon during the carburizing process.

- Heavily copper plating those areas to be left soft. The layer of copper prevents intimate contact between the component and the carburizing medium. Copper plating cannot be used for salt-bath carburizing as the molten salts dissolve the copper.
- Encasing the areas to be left soft in fire-clay. This technique is mostly used when pack carburizing.

- Leaving surplus metal where a soft area is required. This is machined off between carburizing and hardening (dipping off). An example is shown in Fig. 4.18. Although more expensive because of the extra handling involved, it is the most sure and effective way of leaving local soft features.

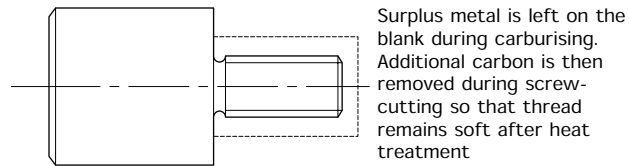


Figure 4.18 Localized case hardening

4.17 The heat treatment of non-ferrous metals and alloys

None of the non-ferrous metals and only a very few non-ferrous alloys can be quenched hardened like plain carbon steels. The majority of non-ferrous metals can only be hardened by cold-working processes. Alternatively they can be manufactured from cold-rolled (spring temper) sheet or strip, or they can be manufactured from cold-drawn wire. Work-hardened non-ferrous metals can be annealed by a recrystallization process that is similar to the process of annealing for plain carbon steels. The main difference is that non-ferrous metals do not have to be cooled slowly. They can be quenched after heating and this has the advantage that the rapid cooling causes the metal to shrink suddenly and this removes the oxide film. In the case of copper and its alloys this is even more effective if the metal is pickled in a weak solution of sulphuric acid whilst still warm. (*Safety.* If an acid bath is used, protective clothing and eye protection such as goggles or, better still, a visor *must* be worn.) Suitable annealing temperatures are:

- Aluminium 500°C to 550°C (pure metal)
- Copper 650°C to 750°C (pure metal)
- Cold-working brass 600°C to 650°C (simple alloy of copper and zinc)

Heat treatable aluminium alloys ('duralumin' is such an alloy) require somewhat different treatment. They can be softened by *solution treatment* and hardened by *natural ageing* or they can be hardened artificially by *precipitation treatment*. The alloy 'duralumin' contains traces of copper, magnesium, manganese and zinc; aluminium makes up the remainder of the alloy.

4.17.1 Solution treatment

To soften duralumin type aluminium alloys, they are raised to a temperature of about 500°C (depending upon the alloy). At this temperature the

alloying elements can form a solid solution in the aluminium. The alloy is quenched from this temperature to preserve the solution at room temperature. Gradually, the solid solution will break down with age and the alloy will become harder and more brittle. Therefore solution treatment must be carried out immediately before the alloy is to be processed. The breakdown of the solution can be delayed by refrigeration at between -6°C and -10°C . Conversely it can be speeded up by raising the temperature.

4.17.2 Precipitation treatment

The natural hardening mentioned above is called *age hardening*. This is the result of hard particles of aluminium–copper compounds precipitating out of the solid solution. This hardens and strengthens the alloy but makes it less ductile and more brittle. Precipitation hardening can be accelerated by heating the alloy to about 150°C to 170°C for several hours. This process is referred to as *artificial ageing* or *precipitation hardening*. The times and temperatures vary for each alloy and the alloy manufacturer's heat treatment specifications must be carefully observed, especially for critical components such as those used in the aircraft industry.

4.18 Heat treatment furnaces

The requirements of heat treatment furnaces are as follows:

- *Uniform heating of the work.* This is necessary in order to prevent distortion of the work due to unequal expansion, and also to ensure uniform hardness.
- *Accurate temperature control.* We have previously discussed the critical nature of heat treatment temperatures. Therefore, not only must the furnace be capable of operating over a wide range of temperatures, it must be easily adjustable to the required process temperature.
- *Temperature stability.* Not only is it essential that the temperature is accurately adjustable but, once set, the furnace must remain at the required temperature. This is achieved by ensuring that the mass of the heated furnace lining (refractory) is very much greater than the mass of the work (charge). It can also be achieved by automatic temperature control, or by both.
- *Atmosphere control.* If the work is heated in the presence of air, the oxygen in the air attacks the surface of the metal to form metal oxides (scale). This not only disfigures the surface of the metal, it can also change the composition of the metal at its surface. For example, in the case of steels, the oxygen can also combine with the carbon at the surface of the metal. Reducing the carbon content results in the metal surface becoming less hard and/or tough.
- To provide atmosphere control, the air in the furnace is replaced with some form of inert gas which will not react with the workpiece material. Alternatively the work may be totally immersed in hot, molten salts.

- *Economical use of fuels.* This is essential if heat treatment costs are to be kept to a minimum. If the furnaces can be run continuously on a shift work basis considerable economies can be made. The fuel required to keep firing up furnaces from cold is much greater than that required for continuous running. Thus it is more economical for small workshops to contract their heat treatment out to specialist firms who have sufficient volume of work to keep their furnaces in continuous use.
- *Low maintenance costs.* The furnace is lined with a heat resistant material such as firebrick. Since the furnace must be taken out of commission each time this lining is renewed, it should be designed to last as long as possible.

4.18.1 Open-hearth furnace

Figure 4.19 shows the simplest form of furnace. This is little different to heating a component on a brazing hearth except that the furnace arch reflects heat back onto the component and provides rather more uniform heating. In this furnace a gas or oil burner plays directly onto the charge. Heat is also reflected onto the work from the furnace lining as previously mentioned. The advantages and limitations of this type of furnace are as follows:

Advantages

- Low initial cost.
- Simplicity in use and maintenance.
- Fuel economy since it heats up quickly.

Limitations

- Uneven heating.
- Poor temperature control.

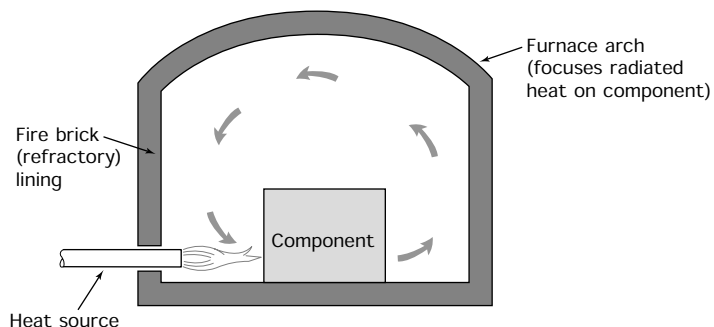


Figure 4.19 Gas-heated open hearth furnace

- Poor temperature stability.
- Complete lack of atmosphere control resulting in heavy scaling and flue gas contamination of the work.

4.18.2 Semi-muffle furnace

Figure 4.20 shows a semi-muffle furnace. This is an improvement upon the open-hearth furnace previously described. The flame from the burner does not play directly onto the charge, but passes under the hearth to provide 'bottom heat'. This results in more uniform heating. The advantages and limitations of this type of furnace are as follows:

Advantages

- Comparatively low initial cost.
- Simplicity in use and maintenance.
- Fuel economy.
- Fairly rapid heating.
- Heating is more uniform than for the open-hearth type of furnace.
- Limited atmosphere control can be achieved by varying the gas-air mixture through a system of dampers. The flue outlets are situated just inside the furnace door so that any atmospheric oxygen that may leak past the door is swept up the flue before it can add to the scaling of the work.
- Reasonable temperature control.
- Reasonable atmosphere stability due to the greater mass of the furnace lining compared with the open-hearth type furnace.

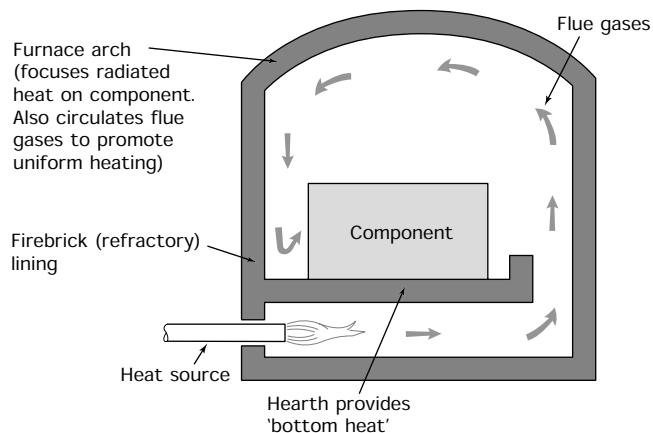


Figure 4.20 *Gas-heated semi-muffle furnace*

Limitations

- Heating is still comparatively uneven compared with more sophisticated furnace types.
- Atmosphere control is somewhat limited. Although oxidation can be reduced by careful control of the gas–air mixture, some scaling will still take place and there will still be flue gas contamination of the work.

4.18.3 Muffle furnace (gas heated)

Figure 4.21 shows a full muffle furnace. You can see from the figure that the work is heated in a separate compartment called a *muffle*. The work is completely isolated from the flame and the products of combustion. The advantages and limitations for this type of furnace are as follows:

Advantages

- Uniform heating.
- Reasonable temperature control.
- Good temperature stability due to the mass of refractory material forming the muffle and the furnace lining compared with the mass of the work.
- Full atmosphere control is possible. Any sort of atmosphere can be maintained within the muffle since no combustion air is required in the muffle chamber.

Limitations

- Higher initial cost.
- Maintenance more complex and costly.

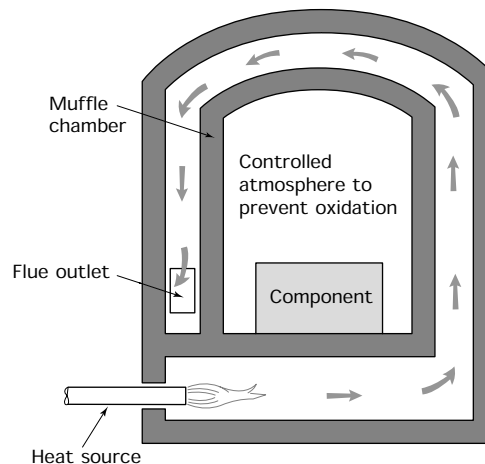


Figure 4.21 Gas-heated muffle furnace

- Greater heat losses and slow initial heating result in lower fuel economy unless the furnace can be operated continuously.

4.18.4 Muffle furnace (electric resistance)

Figure 4.22 shows a typical electric resistance muffle furnace. The electric heating elements are similar to those found in domestic electric ovens. They are independent of the atmosphere in which they operate. Therefore they can be placed within the muffle chamber itself, resulting in a higher operating efficiency compared with the gas heated muffle furnace, which more than offsets the higher energy cost for electricity compared with gas. The advantages and limitations of this type of furnace are as follows:

Advantages

- Uniform heating of the work.
- Accurate temperature control.
- Ease of fitting automatic control instrumentation.
- High temperature stability.
- Full atmosphere control.
- Comparatively easy maintenance.

Limitations

- Higher energy source costs.
- Lower maximum operating temperatures, as above 950°C to 1000°C the life of the resistance elements is low.

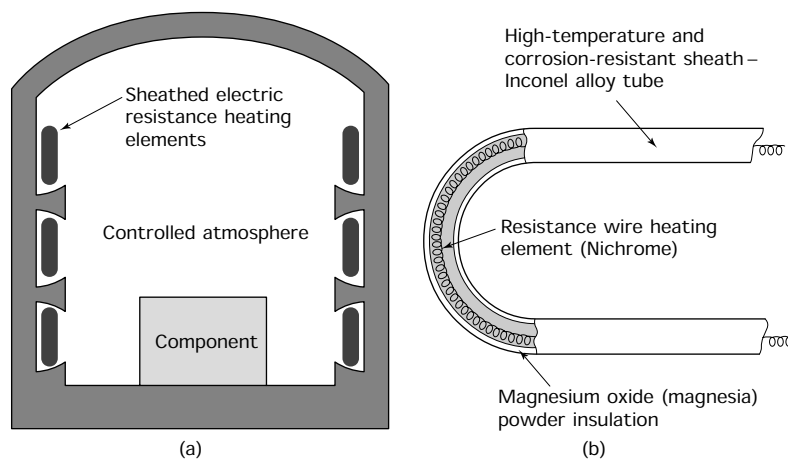


Figure 4.22 *Electrically heated muffle furnace: (a) the electric resistance furnace; (b) heating element*

4.19 Temperature measurement

The importance of temperature measurement and control during heat treatment processes has already been discussed in this chapter. For the high temperatures met with in heat treatment furnaces one or other of the temperature measuring devices known as *pyrometers* is required.

4.19.1 Thermocouple pyrometer

This is the most widely used temperature measuring device for heat treatment purposes. Figure 4.23(a) shows the principle of the thermocouple pyrometer. If the junction of two wires made from dissimilar metals (such as a copper wire and an iron wire) form part of a closed electric circuit and the junction is heated, a small electric current will flow. The presence of this current can be indicated by a sensitive galvanometer. Increasing the temperature difference between the hot and cold junctions increases the current in the circuit. If the galvanometer is calibrated in degrees of temperature, we have a temperature measuring device called a pyrometer.

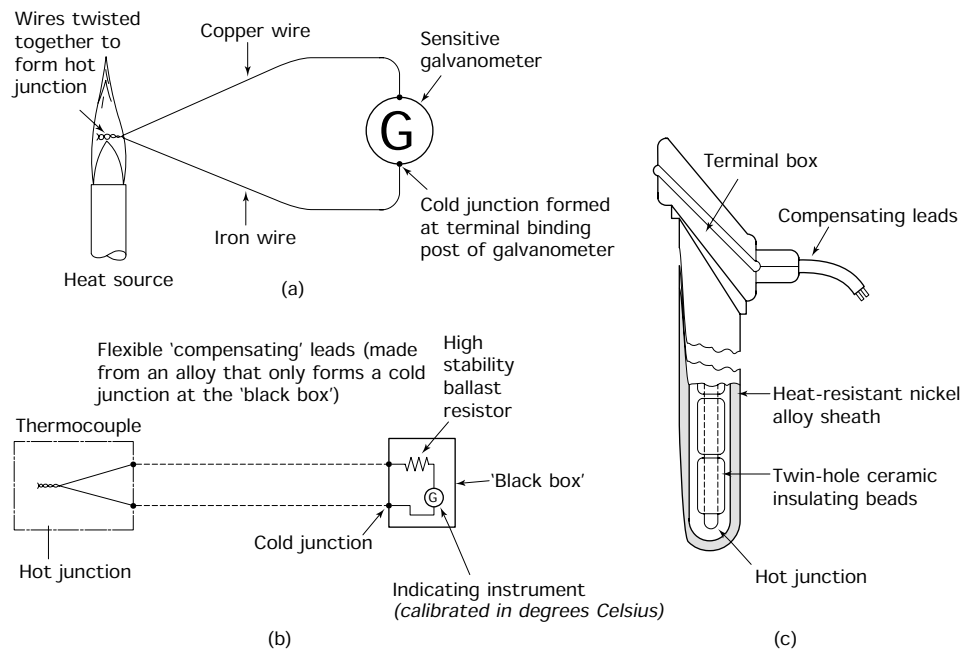


Figure 4.23 *The thermocouple pyrometer: (a) principle of operation; (b) pyrometer circuit; (c) thermocouple probe*

Figure 4.23(b) shows how these principles can be applied to a practical thermocouple pyrometer. The component parts of this instrument are:

- the thermocouple probe (hot junction);
- the indicating instrument (milli-ammeter);

- the ‘ballast’ or ‘swamp’ resistor;
- the compensating leads.

The *thermocouple probe* consists of a junction of two wires of dissimilar metals contained within a tube of refractory metal or of porcelain. Porcelain beads are used to insulate the two wires and locate them in the sheath as shown in Fig. 4.23(c). Table 4.15 lists the more usual hot junction material combinations, together with their temperature ranges and sensitivities.

TABLE 4.15 *Thermocouple combinations*

<i>Thermocouple</i>	<i>Sensitivity (millivolts/°C)</i>	<i>Temperature range (°C)</i>
Copper–constantan	0.054	–220 to + 300
Iron–constantan	0.054	–220 to + 750
Chromel–alumel	0.041	–200 to + 1200
Platinum–platinum/rhodium	0.0095	0 to + 1450

Notes:

Constantan = 60% copper, 40% nickel.

Chromel = 90% nickel, 10% chromium.

Alumel = 95% nickel, 2% aluminium, 3% manganese.

Platinum/rhodium = 90% platinum, 10% rhodium.

The indicating instrument

This is a sensitive milli-ammeter calibrated in degrees celsius (°C) so that a direct reading of temperature can be made. A common error is to set this instrument to read *zero* when the system is cold. In fact it should be set to read the *atmospheric temperature* at the point of installation. The terminals of this instrument form the cold junction and should be placed in a cool position where they are screened from the heat of the furnace.

The ‘ballast’ or ‘swamp’ resistor

This is contained within the case of the indicating instrument. Its purpose is to give stability to the system. The resistance of electrical conductors increases as their temperature increases, and the conductors that make up a pyrometer circuit are no exception. The variation in resistance with temperature would seriously affect the calibration of the instrument if the ballast resistor were not present. This resistor is made from manganin wire. Manganin is an alloy whose resistance is virtually unaffected by heat. By making the resistance of the ballast resistor very large compared with the resistance of the rest of the circuit, it *swamps* the effects of any changes in resistance that may occur in the rest of the circuit and renders them unimportant.

Compensating leads

These are used to connect the thermocouple probe to the indicating instrument. They are made of a special alloy so that they form a cold junction with the terminals of the indicating instrument but not with the terminals of the probe. To avoid changes in calibration, the compensating leads must not be changed in length, nor must alternative conductors be used. The thermocouple, compensating leads and the indicating instrument must always be kept together as a set.

4.19.2 The radiation pyrometer

This device is used to measure the temperature:

- Of large hot components that have been removed from the furnace.
- Where the furnace temperature is so high it would damage the thermocouple probe.
- Where the hot component is inaccessible.
- Where the temperature of the component in the furnace needs to be measured rather than the temperature of the furnace atmosphere itself.

The principle of this type of pyrometer is shown in Fig. 4.24. Instead of the thermocouple probe being inserted into the furnace atmosphere, the radiant heat from the furnace or the component being heated in the furnace is focused onto the thermocouple by a parabolic mirror.

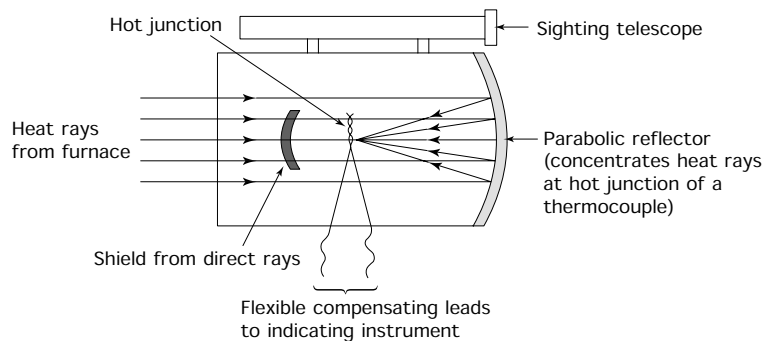


Figure 4.24 *The radiation pyrometer*

Remember that as the temperature of a work reaches the furnace temperature, the rate at which the temperature of the work increases slows down. It is difficult to assess just when, if ever, the component reaches furnace temperature. Certainly, the soaking time involved would give rise to excessive grain growth. Furnaces are frequently operated above the required process temperature, and the work is withdrawn from the furnace when it has reached its correct temperature as measured by a radiation pyrometer.

4.19.3 Temperature assessment

The devices and techniques described above give precise temperature measurement. There are simpler ways of assessing the *approximate* temperature; some of these will now be described.

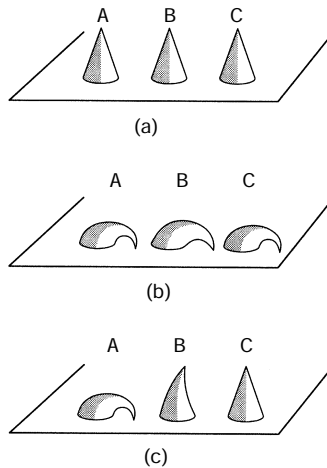


Figure 4.25 Use of Seger cones: (a) temperature too low – no cones soften; (b) temperature too high – all the cones soften; (c) temperature correct – cone A softens and droops, cone B just starts to droop, cone C unaffected

Paints and crayons

These are applied to the surface of the component to be heat treated. The mark left on the surface by their application changes in colour and appearance when the desired temperature has been reached. The paints and crayons are available in a range of compositions to suit the temperature required. They have the advantage of indicating the temperature of the component at the point of application. It has been stated previously that the temperature of the charge does not necessarily reflect the temperature in the furnace. They can also be used to indicate the pre-heating temperature of components to be joined by welding. Another application is to mark the blades of gas turbines (jet engines) so, when undergoing routine maintenance, it can be seen if the blades have been overheated and therefore weakened.

Ceramic cones

These are also known as ‘Seger’ cones and may be conical or pyramidal in shape. The latter have a triangular base. The ‘cones’ are made with various compositions so that they soften at different temperatures. It is usual to choose three cones, one slightly below the required temperature (cone A in Fig. 4.25), the second at the required temperature (cone B in Fig. 4.25), and a third slightly above the required temperature (cone C in Fig. 4.25).

- If the furnace is below the required temperature none of the cones soften and droop as shown in Fig. 4.25(a).
- If the furnace is too hot, all the cones will droop as shown in Fig. 4.25(b).
- If the furnace is at the correct temperature, cone A will droop a lot, cone B will just start to droop at the tip, and cone C will be unaffected. This situation is shown in Fig. 4.25(c).

4.20 Atmosphere control

When natural gas is burnt in a furnace, excess air is usually present to ensure complete and efficient combustion. The resulting *products of combustion* (flue gases) contain oxygen, carbon dioxide, sulphur, nitrogen and water vapour. These all react to a greater or lesser degree with the surface of the workpiece whilst it is in the furnace. They will produce heavy scaling and, in the case of steel, surface decarburization and softening. The situation is not so serious in the case of a muffle furnace as the fuel is burnt in a separate chamber and cannot come into contact with the work. However, the oxygen and water vapour in the air are still present

in the muffle chamber and will cause some scaling and decarburization of the work.

Little can be done to offset this effect in simple furnaces. However, in muffle furnaces air in the muffle chamber can be replaced by alternative atmospheres, depending upon the process being performed and the metal being treated. This is known as *atmosphere control*. These controlled atmospheres can be based upon natural gas (methane) and LPG gases such as propane and butane. For special applications, ammonia gas and 'cracked' ammonia gas are used.

Exercises

4.1 *Material properties*

- (a) Name the properties required by the materials used in the following applications:
- (i) A metal-cutting tool.
 - (ii) A forged crane hook.
 - (iii) A motor car radiator.
 - (iv) A motor car road wheel axle.
 - (v) The conductors in an electric cable.
 - (vi) A crane sling.
 - (vii) The sheathing of an electric cable.
 - (viii) A kitchen sink.
 - (ix) A garden hosepipe.
 - (x) Concrete for a machine foundation.
 - (xi) Lathe tailstock.
- (b) Giving reasons for your choice, name a suitable plain carbon steel and state its heat treatment condition for each of the following applications.
- (i) Cold chisel.
 - (ii) Engineer's file.
 - (iii) Vehicle leaf spring.
 - (iv) Sheet steel for pressing out car body panels.
 - (v) Rod for making small turned parts on an automatic lathe.

4.2 *Material applications and classification*

- (a) Copy out and complete Table 4.16.

TABLE 4.16 *Exercise 4.2(a)*

<i>Material</i>	<i>Typical application</i>
Cast iron	
High-speed steel	
Duralumin	
Stainless steel (austenitic)	
Gunmetal	
Phosphor bronze	

(continued overleaf)

TABLE 4.16 (continued)

<i>Material</i>	<i>Typical application</i>
70/30 Brass	
60/40 Brass	
Free-cutting brass	
Tufnol	
Nylon	
PTFE	
Perspex	
Polystyrene	
PVC	
Glass fibre-reinforced polyester	
Epoxy resin	
Urea–formaldehyde	

- (b) Copy out and complete Table 4.17 by explaining briefly the meaning of the following terms:

TABLE 4.17 *Exercise 4.2(b)*

<i>Term</i>	<i>Meaning</i>	<i>Example</i>
Ferrous metal		
Non-ferrous metal		
Thermoplastic		
Thermosetting plastic		
Synthetic material		
Natural material		
Metallic		
Non-metallic		
Alloy		

4.3 *Forms of supply, identification, and specification*

- (a) Table 4.18 lists a number of material applications. Copy out and complete the table by naming the ‘form of supply’ in which you would expect to receive the material for each application.
- (b) (i) State the meaning of the following abbreviations as applied to plain carbon steels: MS, BDMS, HRPO, CRCA.
(ii) What do the terms ‘quarter-hard’, ‘half-hard’, etc., refer to when ordering non-ferrous sheet metal and rolled strip?
- (c) Describe the methods of material identification used in the raw material stores at your place of work or your training workshop.
- (d) The following specifications are based upon the current edition of BS 970. Explain their meaning.

TABLE 4.18 Exercise 4.3(a)

<i>Applications</i>	<i>Form of supply</i>
Car body panels	
Lathe bed	
Turned parts	
Plastic mouldings	
Structural steel work	
The two main raw materials for GRP boat hull mouldings	
Plastic window frames	
Connecting rods for high-power motor cycle engines	

- (i) 080 A15
- (ii) 080 M 15
- (iii) 230 M 07
- (iv) 230 M 07 (lead)
- (v) 080 M 40
- (vi) 605 M 36
- (vii) 708 M 40
- (viii) 817 M 40

4.4 *Heat treatment safety*

- (a) Briefly describe the type of clothing and protective devices you should wear when carrying out heat treatment processes.
- (b) Sketch THREE warning signs you would expect to find in a heat treatment shop.

4.5 *Reasons for heat treatment*

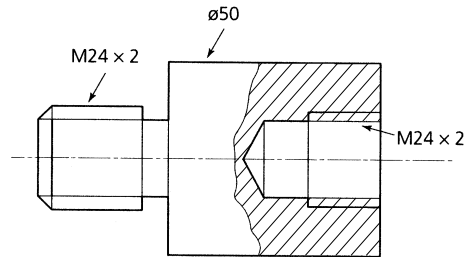
- (a) State the main TWO purposes for the heat treatment of metallic materials.
- (b) Explain why a coppersmith would anneal a blank cut from a sheet of copper before beating it to shape, and why would he/she need to re-anneal the metal from time to time as forming proceeds.

4.6 *Hardening plain carbon steels*

- (a) What two factors does the hardness of a plain carbon steel depend upon when through-hardening?
- (b) Explain why steels have to be tempered after hardening and how the degree of temper is controlled when this is done over a brazing hearth in the workshop.
- (c) When through-hardening, what is the effect of:
 - (i) overheating the steel;
 - (ii) underheating the steel.
- (d) When through-hardening, explain how the hot metal should be quenched and what precautions must be taken to avoid cracking and distortion.

4.7 Local hardening

- (a) With the aid of sketches show how a simple component can be superficially case hardened at the brazing hearth in a workshop.
- (b) List the operations for case hardening the component shown in Fig. 4.26 so that the threads are left soft.

**Figure 4.26** *Exercise 4.7(b)*

- (c) Name an example of:
 - (i) a solid case-hardening compound;
 - (ii) a gaseous case-hardening compound;
 and give an example where each would be used.

4.8 Annealing and normalizing

- (a) Describe the essential differences between annealing and normalizing plain carbon steels.
- (b) Describe the essential differences between full annealing and subcritical annealing as applied to plain carbon steels.
- (c) Describe the essential differences between the annealing of plain carbon steels and the annealing of non-ferrous metals (other than the heat treatable aluminium alloys).
- (d) Describe how 'duralumin' is softened. What is the name of the process used, and what is the name of the natural process by which this aluminium alloy gradually becomes hard again?

4.9 Heat treatment equipment

- (a) List the main requirements of a heat treatment furnace.
- (b) With the aid of sketches describe any heat treatment furnace with which you are familiar. Draw particular attention to its main features. List the main advantages and limitations for the furnace type chosen.
- (c) Describe the precautions that must be taken when starting up and shutting down furnaces.
- (d) Describe the need for, and a method of, atmosphere control in heat treatment furnaces.
- (e) Describe a method of temperature measurement suitable for a furnace used for the occasional hardening of high carbon steel components.

5 Engineering drawing

When you have read this chapter you should understand how to:

- Interpret (read) drawings in first and third angle projection.
- Sketch and dimension mechanical components in first and third angle projection.
- Sketch mechanical components in isometric and oblique projection.

5.1 Engineering drawing (introduction)

Figure 5.1(a) shows a drawing of a simple clamp. This is a pictorial drawing. It is very easy to see what has been drawn, even to people who have not been taught how to read an engineering drawing. Unfortunately such drawings have only a limited use in engineering. If you try to put

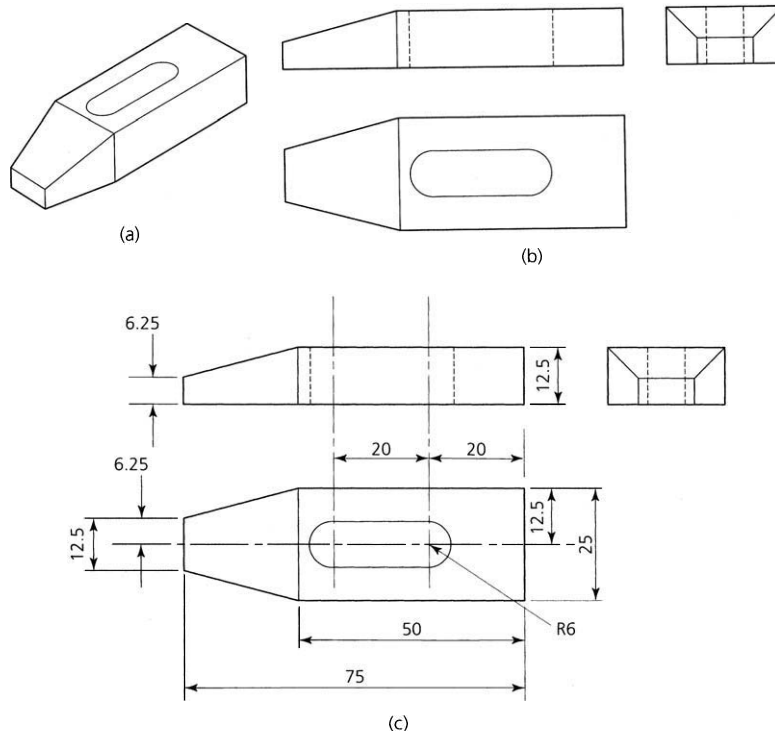


Figure 5.1 Clamp: (a) pictorial drawing; (b) orthographic drawing; (c) fully dimensioned in millimetres

all the information that is required to make the clamp onto this drawing it would become very cluttered and difficult to interpret. Therefore we use a system called *orthographic drawing* when we make engineering drawings.

An example of an orthographic drawing of our clamp is shown in Fig. 5.1(b). We now have a collection of drawings each one looking at the clamp from a different direction. This enables us to show every feature of the clamp that can be seen and also some things that cannot be seen (hidden details). Features that cannot be seen are indicated by broken lines. Finally we can add the sizes (dimensions) that we need in order to make the clamp. These are shown in Fig. 5.1(c). A drawing that has all the information required to make a component part, such as Fig. 5.1(c), is called a *detail drawing*, but more of that later.

5.2 First angle orthographic drawing

There are two systems of orthographic drawing used by engineers:

- First angle or English projection.
- Third angle or American projection.

In this section we are going to look at *first angle* projection. We are again going to use the clamp you first met in Fig. 5.1(a). We look at the clamp from various directions.

- Look down on the top of the clamp and draw what you see as shown in Fig. 5.2(a). This is called a *plan view*.
- Look at the end of the clamp and draw what you see as shown in Fig. 5.2(a). This is called an *end view*.
- Look at the side of the clamp and draw what you see as shown in Fig. 5.2(a). Although this is a side view, it is given a special name. It is called an *elevation*.
- You can now assemble these views together in the correct order as shown in Fig. 5.2(b) to produce a *first angle orthographic drawing* of the clamp.

As well as the things that can be seen from the outside of the clamp, we also included some 'hidden detail' in the end view and elevation. Hidden detail indicates a slot through the clamp in this example. The slot is shown by using *broken lines*. We did this because if we had shown the slot as an oval in the plan view it could have meant one of two things:

- A slot passing right through the clamp.
- A slot recessed part way into the clamp.

It *could not* have been an oval-shaped lump on top of the clamp as this would have shown up in the end view and in the elevation.

Sometimes only two views are used when the plan and elevation are the same. For example, a cylindrical component such as a shaft. Figure 5.3

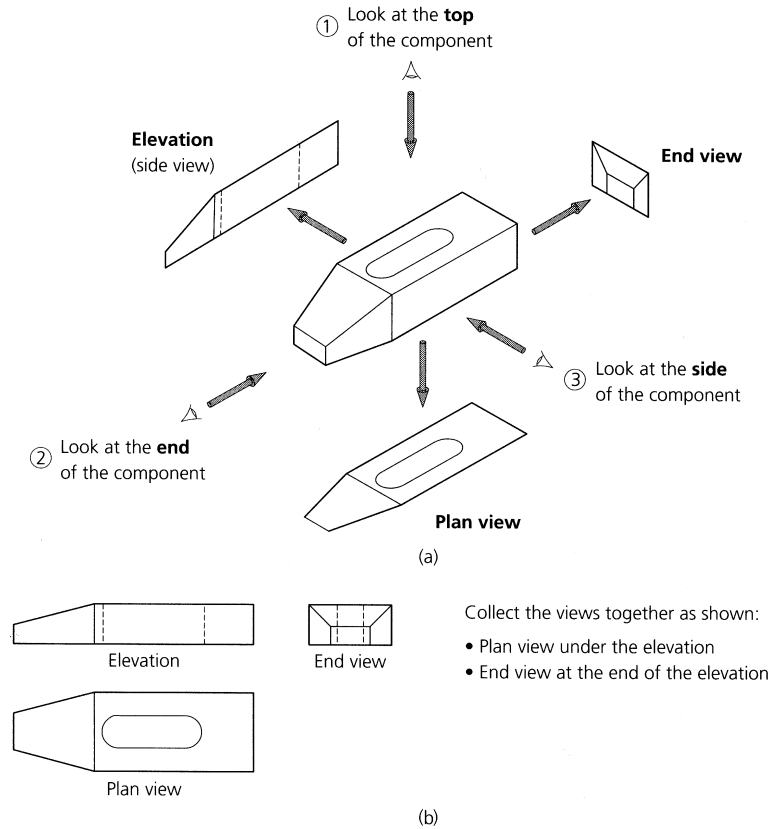


Figure 5.2 Principles of drawing in first angle projection: (a) plan view, end view, and elevation (side view); (b) collected views together make up an orthographic drawing

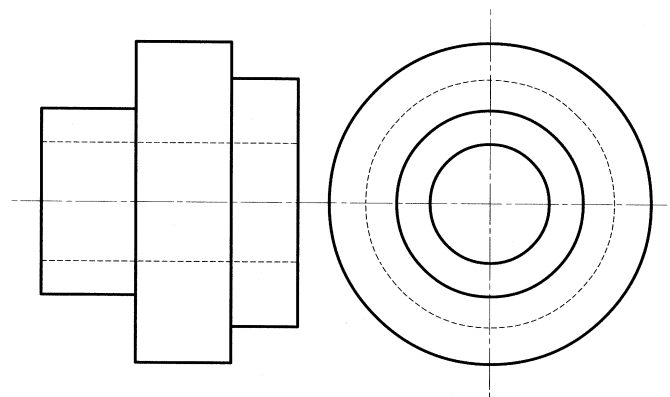


Figure 5.3 First angle drawing of a cylindrical component: the elevation and plan views are the same and need only be drawn once

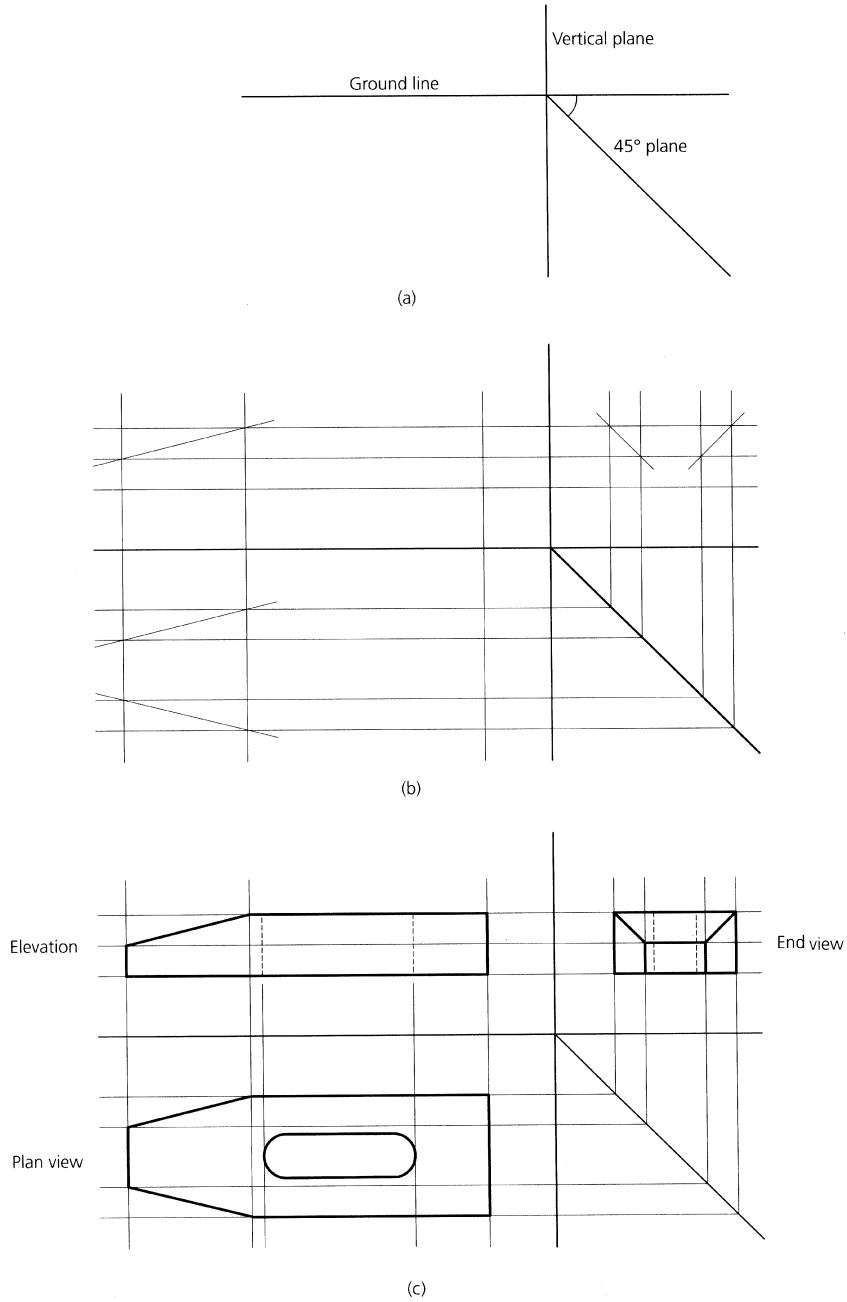


Figure 5.4 *Making a drawing in first angle projection: (a) ground line and planes; (b) initial construction lines; (c) line in the outline (outline is twice the thickness of the construction lines)*

shows that an elevation and an end view provide all the information we require.

Finally let's see how a first angle orthographic drawing is constructed.

- First draw the ground lines and a plane at 45° as shown in Fig. 5.4(a).
- Then start to draw in the construction lines faintly using lines that are half the thickness of the final outline. Figure 5.4(b) shows the construction lines in place.
- Then follow each construction line round all the views in order to avoid confusion.
- Finally, we 'line in' the outline so that it stands out boldly as shown in Fig. 5.4(c).

5.3 Third angle orthographic drawing

To draw the clamp in third angle (American) orthographic projection, you merely have to rearrange the relative positions of the views. Each view now appears at the same side or end of the component from which you are looking at it. This is shown in Fig. 5.5(a). That is:

- Look down on the clamp and draw the plan view above the side view or elevation.
- Look at the left-hand end of the clamp and draw the end view at the same end.

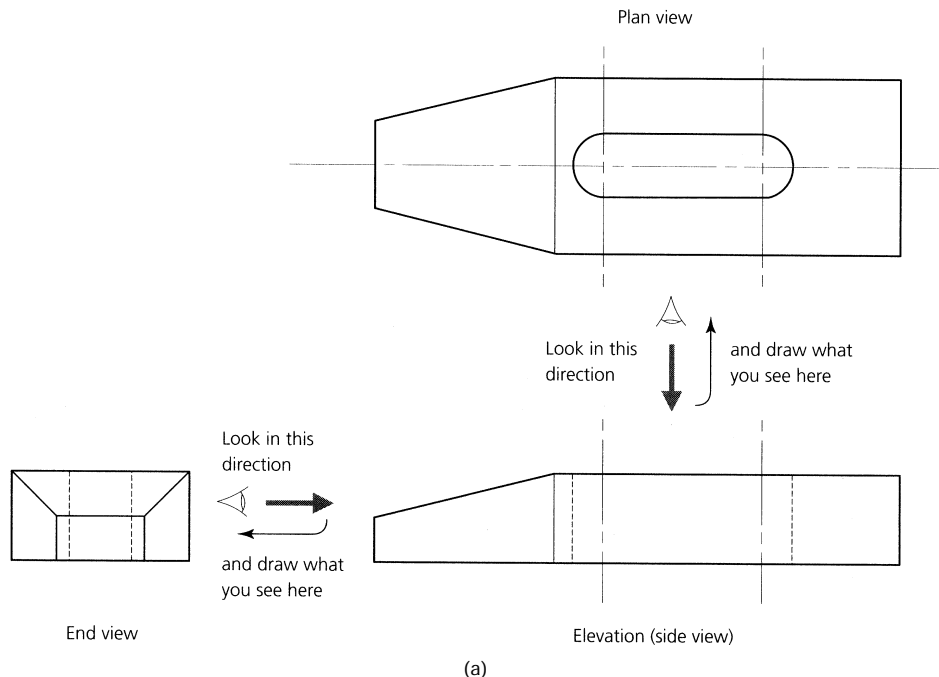


Figure 5.5 (a) Principles of drawing in third angle projection; (b) projection symbol

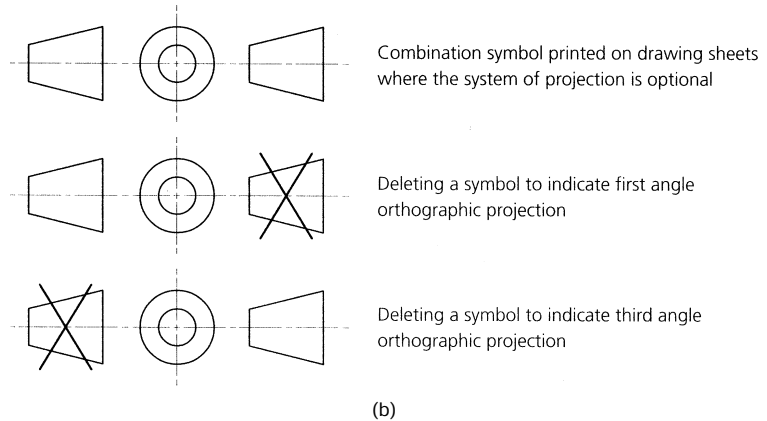


Figure 5.5 (continued)

So what is the advantage of third angle projection? Consider the general arrangement drawing for an airliner drawn to a fairly large scale so that fine detail can be shown. In first angle projection, the end view looking at the nose of the aircraft would be drawn somewhere beyond the tail. An end view looking at the tail of the aircraft would be drawn somewhere beyond the nose. It is much more convenient to draw the end view of the nose of the aircraft at the nose end of the elevation. Also, it is more

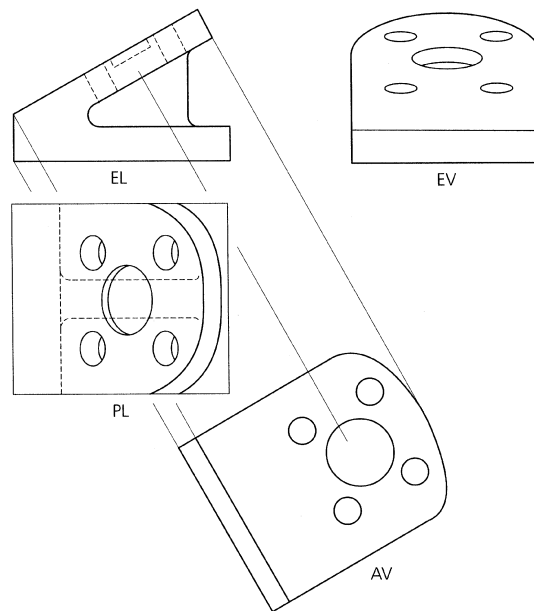


Figure 5.6 Auxiliary view: *EL* = elevation; *EV* = end view; *PL* = plan; *AV* = auxiliary view

convenient to draw an end view of the tail of an aircraft next to the tail of the elevation.

To avoid confusion, always state the projection used on the drawing. Sometimes the projection used is stated in words, more usually it is indicated by the use of a standard symbol. Figure 5.5(b) shows the combined projection symbol and how it is used.

So far we have only considered features that are conveniently arranged at right angles to each other so that their true shape is shown in the plan, elevation or the end view. This is not always the case and sometimes we have to include an *auxiliary view*. This technique is important in the production of working drawings so that the positions of features on the surface that is inclined not only appear undistorted but can also be dimensioned. Figure 5.6 shows a bracket with an inclined face. When it is drawn in first angle projection, it can be seen that the end view showing the inclined surface and its features is heavily distorted. However, these features appear correct in size and in shape in the auxiliary view (AV) which is projected at right angles (perpendicular) to the inclined face.

5.4 Conventions

An engineering drawing is only a means of recording the intentions of the designer and communicating those intentions to the manufacturer. It is not a work of art and, apart from the time spent in its preparation, it has no intrinsic value. If a better and cheaper method of communication could be discovered, then the engineering drawing would no longer be used. We are already part way along this road with CAD where the drawings are stored digitally on magnetic or optical disks and can be transmitted between companies by the internet. However, hard copy, in the form of a printed drawing, still has to be produced for the craftsperson or the technician to work to.

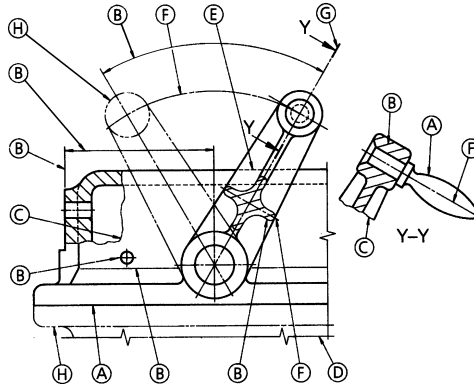
As an aid to producing engineering sketches and drawings quickly and cheaply we use *standard conventions*. These are recognized internationally and are used as a form of drawing ‘shorthand’ for the more frequently used details.

In the UK we use the British Standard for Engineering Drawing Practice as published by the British Standards Institute (BSI). This standard is based upon the recommendations of the International Standards Organization (ISO) and, therefore, its conventions and guidelines, and drawings produced using such conventions and guidelines are accepted internationally.

5.4.1 Types of line

Figure 5.7 shows the types of line recommended by BS 308, together with some typical applications. The following points should be noted in the use of these lines.

- *Dashed* lines should consist of dashes of consistent length and spacing, approximately to the proportions shown in the figure.



Line	Description	Application
A	Continuous thick	Visible outlines and edges
B	Continuous thin	Dimension, projection and leader lines, hatching, outlines of revolved sections, short centre lines, imaginary intersections
C	Continuous thin irregular	Limits of partial or interrupted views and sections, if the limit is not an axis
D	Continuous thin straight with zigzags	
E	Dashed thin	Hidden outlines and edges
F	Chain thin	Centre lines, lines of symmetry, trajectories and loci, pitch lines and pitch circles
G	Chain thin, thick at ends and changes of direction	Cutting planes
H	Chain thin double	Outlines and edges of adjacent parts, outlines and edges of alternative and extreme positions of movable parts, initial outlines prior to forming, bend lines on developed blanks or patterns

Figure 5.7 *Types of line and their applications*

- *Thin chain lines* should consist of long dashes alternating with short dashes. The proportions should be generally as shown in the figure, but the lengths and spacing may be increased for very long lines.
- *Thick chain lines* should have similar lengths and spacing as for thin chain lines.
- *General.* All chain lines should start and finish with a long dash. When thin chain lines are used as centre lines, they should cross one another at solid portions of the line. Centre lines should extend only a short distance beyond the feature unless required for dimensioning or other purposes. They should not extend through the spaces between the views and should not terminate at another line of the drawing. Where angles are formed in chain lines, long dashes should meet at the corners and should be thickened as shown. Arcs should join at tangent points. Dashed lines should also meet at corners and tangent points with dashes.

5.4.2 Abbreviations for written statements

Table 5.1 lists the standard abbreviations for written statements as used on engineering drawings. Some examples of their use are shown in Fig. 5.8. Some further examples will be given when we discuss the dimensioning of drawings.

TABLE 5.1 *Abbreviations for written statements*

<i>Term</i>	<i>Abbreviation</i>	<i>Term</i>	<i>Abbreviation</i>
Across flats	A/F	Hexagon head	HEX HD
British Standard	BS	Material	MATL
Centres	CRS	Number	NO.
Centre line	CL <i>or</i> C	Pitch circle diameter	PCD
Chamfered	CHAM	Radius (in a note)	RAD
Cheese head	CH HD	Radius (preceding a dimension)	R
Countersunk	CSK		
Countersunk head	CSK HD	Screwed	SCR
Counterbore	C'BORE	Specification	SPEC
Diameter (in a note)	DIA	Spherical diameter or radius	SPHERE \emptyset <i>or</i> R
Diameter (preceding a dimension)	\emptyset	Spotface	S'FACE
Drawing	DRG	Standard	STD
Figure	FIG.	Undercut	U'CUT
Hexagon	HEX		

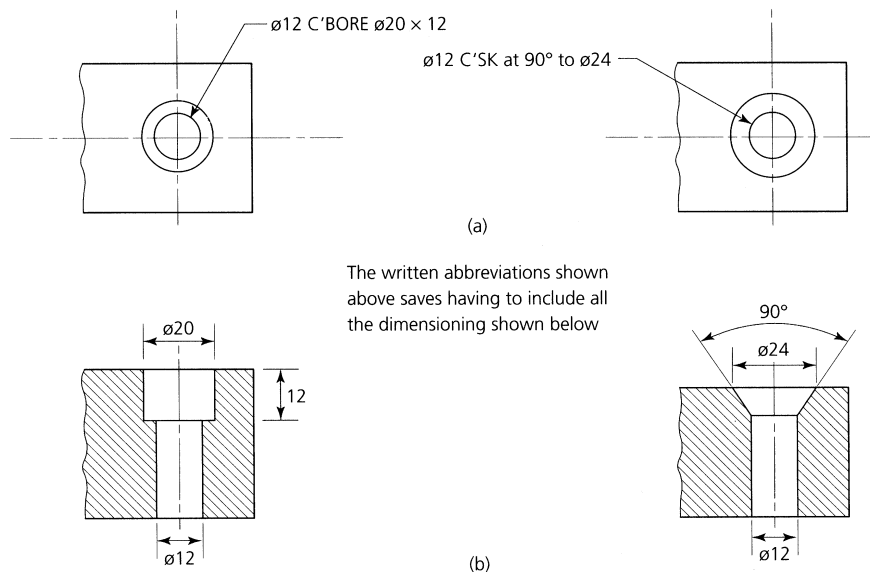


Figure 5.8 *Examples of the use of standard abbreviations: (a) counterbored hole; (b) countersunk hole*

5.4.3 Conventions

Figure 5.9 shows some typical conventions used in engineering drawings. It is not possible, in the scope of this book, to provide the full set of conventions or to provide detailed explanations of the use. For this it is necessary to consult texts specializing in engineering drawing together with British Standard 308. The full standard is expensive but you should find the special abridged edition, BS PP7308: 1986: Engineering Drawing Practice for Schools and Colleges, adequate for your needs. This edition is published at a very affordable price.

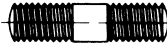
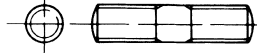
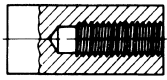
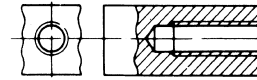
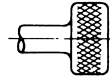
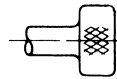
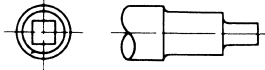
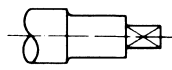
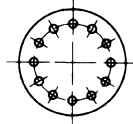
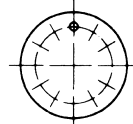
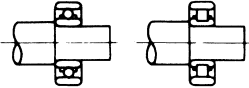
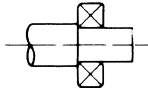
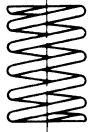
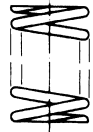
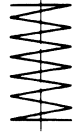
TITLE	SUBJECT	CONVENTION	
External screw threads (detail)			
Internal screw threads (detail)			
Diamond knurling			
Square on shaft			
Holes on circular pitch			
Bearings			
TITLE	SUBJECT	CONVENTION	DIAGRAMMATIC REPRESENTATION
Cylindrical compression spring			

Figure 5.9 *Typical conventions for some common features*

5.5 Redundant views

It has been stated and shown earlier that where a component is symmetrical you do not always require all the views to provide the information required for manufacture. A ball looks the same from all directions, and to represent it by three circles arranged as a plan view, an elevation and an end view would just be a waste of time. All that is required is one circle and a note that the component is spherical. The views that

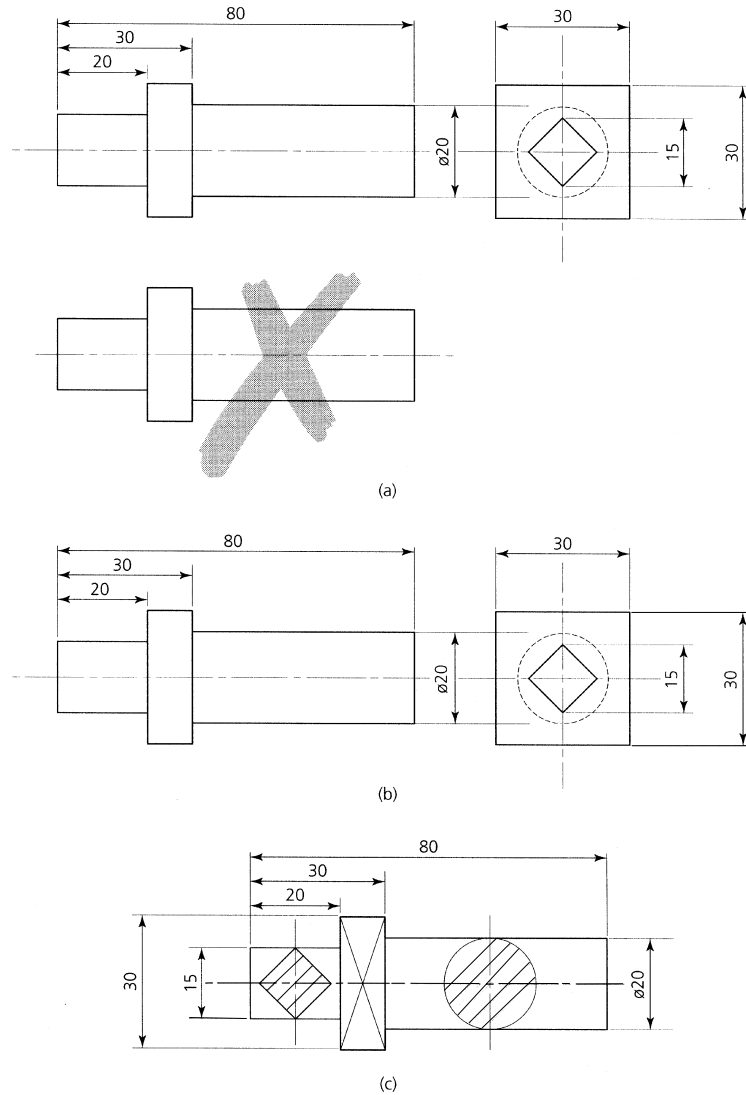


Figure 5.10 Redundant views: (a) first angle working drawing of a symmetrical component (plan view redundant); (b) symmetrical component reduced to two views; (c) working drawing reduced to a single view by using revolved sections and BS convention for the square flange

can be discarded without loss of information are called *redundant views*. Figure 5.10 shows how drawing time can be saved and the drawing simplified by eliminating the redundant views when drawing symmetrical components.

5.6 Dimensioning

So far, only the shape of the component has been considered. However, in order that components can be manufactured, the drawing must also show the size of the component and the position and size of any features on the component. To avoid confusion and the chance of misinterpretation, the dimensions must be added to the drawing in the manner laid down in BS 308. Figure 5.11(a) shows how projection and dimension lines are used to relate the dimension to the drawing, whilst Fig. 5.11(b) shows the correct methods of dimensioning a drawing.

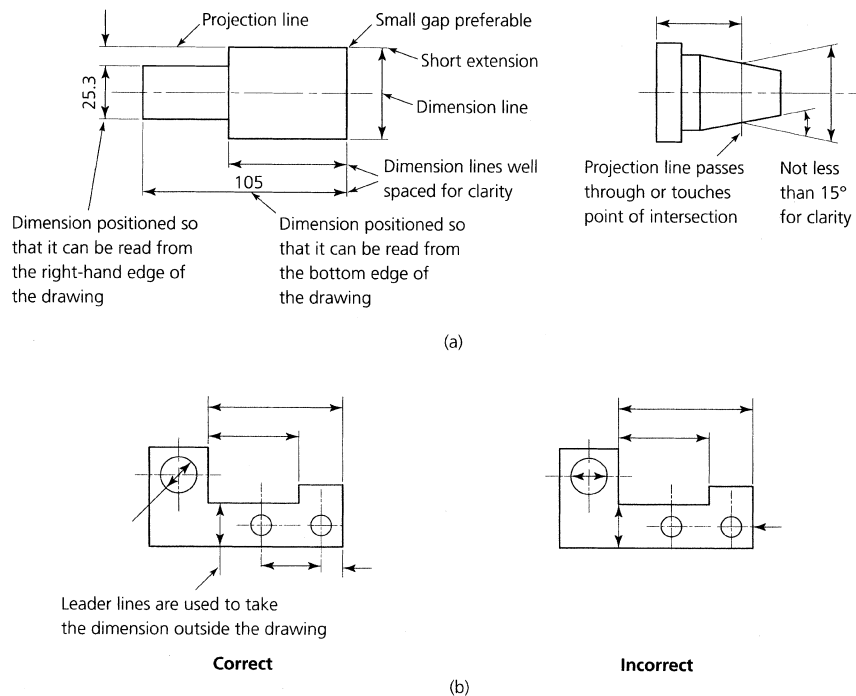


Figure 5.11 *Dimensioning: (a) projection and dimension lines; (b) correct and incorrect dimensioning*

5.6.1 Correct dimensioning

- Dimension lines should be thin full lines not more than half the thickness of the component outline.
- Wherever possible, dimension lines should be placed outside the outline of the drawing.

- The dimension line arrowhead must touch but not cross the projection line.
- Dimension lines should be well spaced so that the numerical value of the dimension can be clearly read and so that they do not obscure the outline of the drawing.

5.6.2 Incorrect dimensioning

- Centre lines and extension lines must *not* be used as dimension lines.
- Wherever possible dimension line arrowheads must not touch the outline directly but should touch the projection lines that extend from the outline.
- If the use of a dimension line within the outline is unavoidable, then try to use a leader line to take the dimension itself outside the outline.

5.6.3 Dimensioning diameters and radii

Figure 5.12(a) shows how circles and shaft ends (circles) should be dimensioned. It is preferable to use those techniques that take the dimension

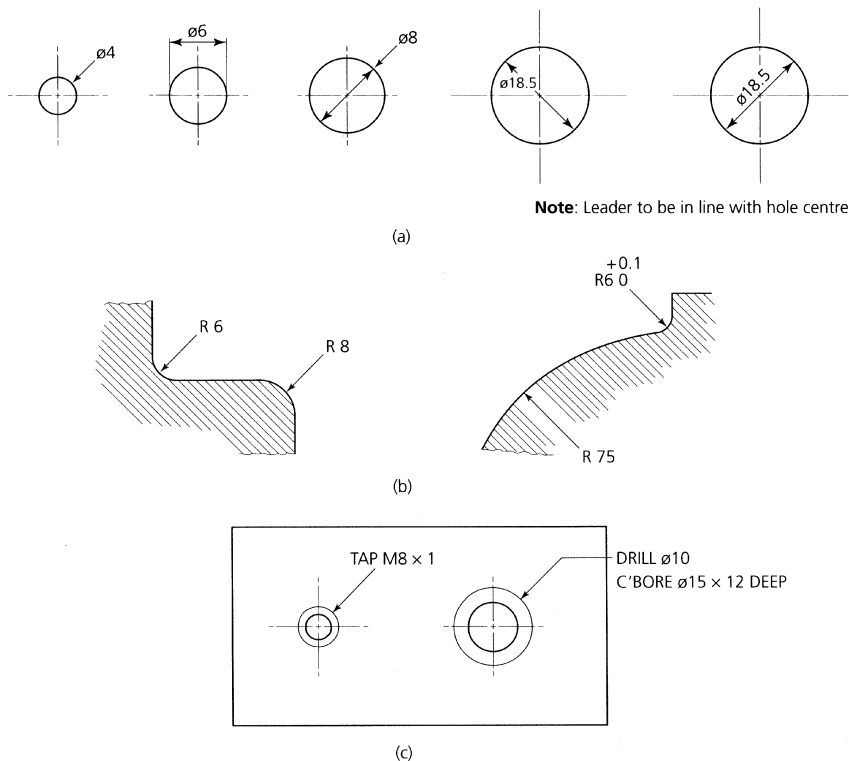


Figure 5.12 Dimensioning – diameters and radii: (a) dimensioning holes; (b) dimensioning the radii of arcs which need not have their centres located; (c) use of notes to save full dimensioning

outside the circle, unless the circle is so large that the dimension will neither be cramped nor will it obscure some vital feature. Note the use of the symbol \varnothing to denote a diameter.

Figure 5.12(b) shows how radii should be dimensioned. Note that the radii of arcs of circles need not have their centres located if the start and finish points are known.

Figure 5.12(c) shows how notes may be used to avoid the need for the full dimensioning of certain features of a drawing.

Leader lines

These indicate where notes or dimensions are intended to apply and end in either arrowheads or dots.

- *Arrowheads* are used where the leader line touches the outline of a component or feature.
- *Dots* are used where the leader line finishes within the outline of the component or feature to which it refers.

5.6.4 Auxiliary dimensions

It has already been stated that, to avoid mistakes, duplicated or unnecessary dimensions should not appear on a drawing. The only exception to this rule is when *auxiliary dimensions* are used to avoid the calculation of,

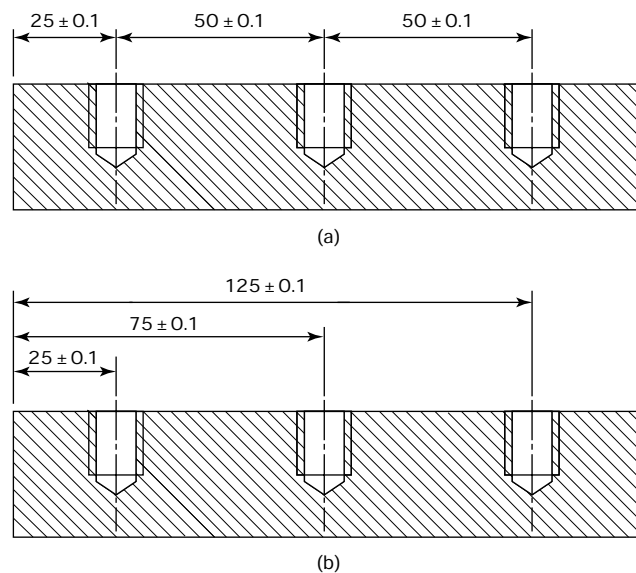


Figure 5.13 *Cumulative error: (a) string (incremental) dimensioning – cumulative tolerance equals sum of individual tolerances; (b) dimensioning from one common datum (absolute dimensioning) to eliminate cumulative effect (dimensions in millimetres)*

say, overall dimensions. Such auxiliary dimensions are placed in brackets as shown in Fig. 5.13. Auxiliary dimensions are also sometimes referred to as *non-functional* dimensions.

5.7 Toleranced dimensions

It is true to say that if ever a component was made exactly to size no one would ever know because it could not be measured exactly. Having calculated the ideal size for a dimension, the designer must then decide how much variation from that size he will tolerate. This variation between the smallest and the largest acceptable size is called the *tolerance*.

When toleranced dimensions are used, *cumulative errors* can occur wherever a feature is controlled by more than one toleranced dimension as shown in Fig. 5.13(a). It can be seen that chain dimensioning gives a build-up of tolerance that is greater than the designer intended. In this example the maximum tolerance for the right-hand hole centre is three times the individual tolerances. That is, the sum of the individual tolerances is $(\pm 0.1) + (\pm 0.1) + (\pm 0.1) \text{ mm} = \pm 0.3 \text{ mm}$ from the left-hand datum edge. This *cumulative* effect can be eliminated easily by dimensioning each feature individually from a common datum as shown in Fig. 5.13(b).

It is not usually necessary to tolerance every individual dimension, only the important ones. The rest can be given a *general tolerance* in the form of a note in the title block as shown in Fig. 5.14. This general statement may refer either to *open dimensions* or it may say *except where otherwise stated*. In the examples shown, the general tolerance is 0.5 mm

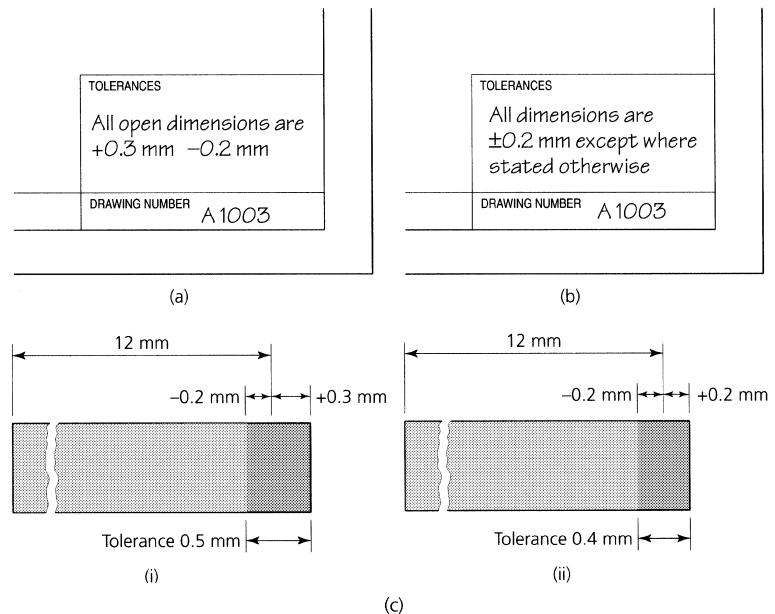


Figure 5.14 General tolerances

with the limits stated as $+0.3$ mm and -0.2 mm in the example shown in Fig. 5.15(a) and with limits stated as ± 0.2 mm in the example shown in Fig. 5.14(b). Both examples mean the same thing. Applied to an open dimension of 12 mm, the actual size is acceptable if it lies as shown in Fig. 5.14(c).

5.8 Sectioning

Sectioning is used to show the internal details of engineering components that cannot be shown clearly by other means. The stages of making a sectioned drawing are shown in Fig. 5.15. It should be realized that the steps (a), (b) and (c) are performed mentally in practice and only (d) is actually drawn.

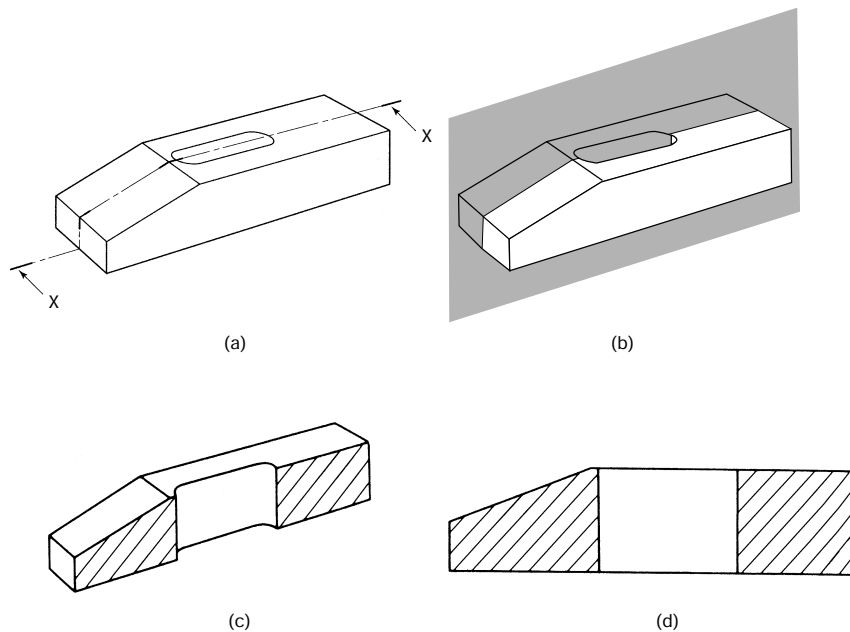


Figure 5.15 Section drawing: (a) the clamp is to be sectioned along line X–X; (b) the cutting plane is positioned on the line X–X as shown; (c) that part of the clamp that lies in front of the cutting plane is removed leaving the sectioned component; (d) sectioned orthographic elevation of the clamp shown in (a) – note that section shading lines lie at 45° to the horizontal and are half the thickness of the outline

The rules for producing and reading sectioned drawings can be summarized as follows.

- Drawings are only sectioned when it is impossible to show the internal details of a component in any other way.
- Bolts, studs, nuts, screws, keys, cotters and shafts are not usually sectioned even when the cutting plane passes through them.

- Ribs and webs are not sectioned when parallel to the cutting plane.
- The cutting plane must be indicated in the appropriate view.
- Hidden detail is not shown in sectioned views when it is already shown in another view.
- The section shading (hatching) is normally drawn at 45° to the outline of the drawing using thin, continuous lines that are half the thickness of the outline. If the outline contains an angle of 45° then the hatching angle can be changed to avoid confusion.
- Adjacent parts are hatched in opposite directions. To show more than two adjacent parts, the spacing between the hatched lines can be varied. A practical example of sectioning is shown in Fig. 5.16.

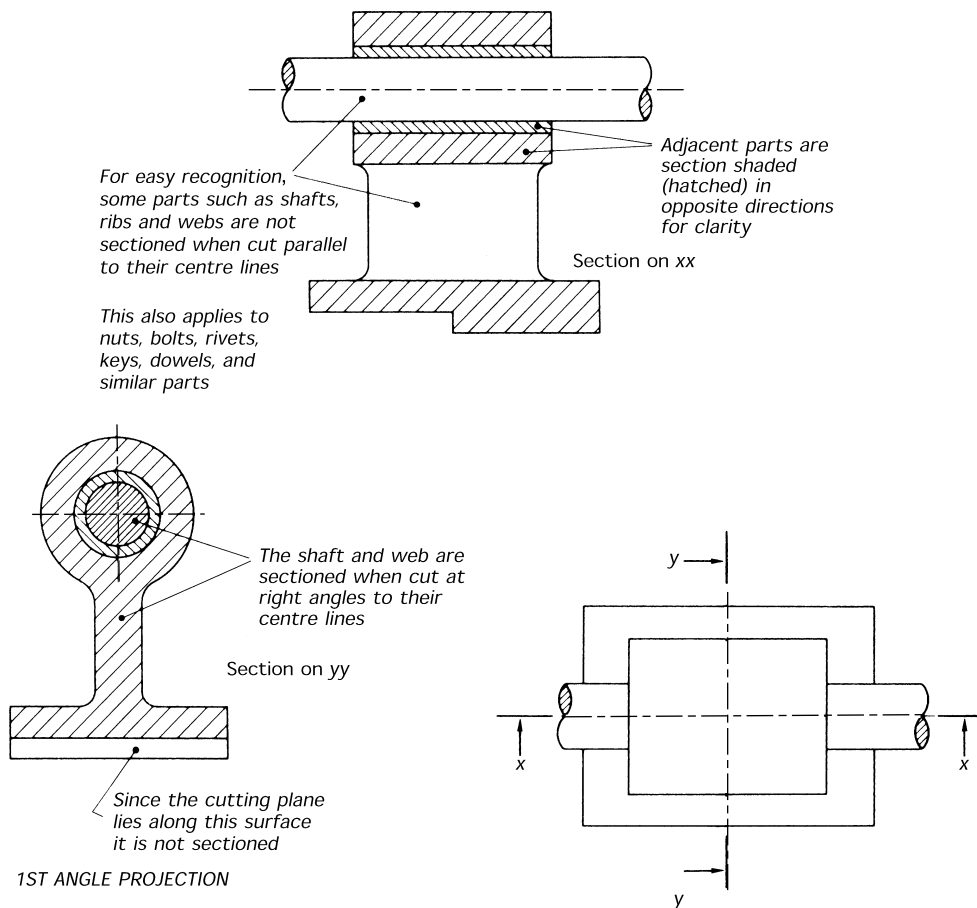


Figure 5.16 Practical sectioning

5.9 Machining symbols

Machining symbols and instructions are used to:

- specify a particular surface finish;
- determine a machining process;
- define which surfaces are to be machined.

Figure 5.17(a) shows the standard machining symbol (BS 308) and the proportions in millimetres to which it should be drawn. When applied to views of a drawing, as shown in Fig. 5.17(b), the symbol should be drawn as follows (in this context ‘normal’ means ‘at right angles to’):

- Normal to a surface.
- Normal to a projection line.
- Normal to an extension line.
- As a general note.

Because a machining symbol is interpreted as a precise instruction, its form should be drawn carefully. Figure 5.17(c) shows three fundamental variations of the symbol.

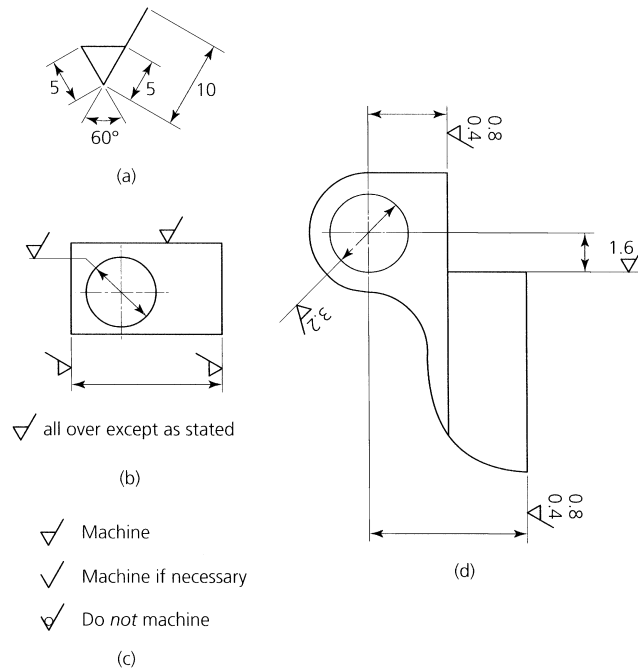


Figure 5.17 *The machining symbol: (a) drawing a machining symbol; (b) applying the machining symbol as an instruction; (c) machining symbols; (d) specifying surface texture on a casting – dimensions omitted for clarity*

These symbols must be used carefully; one incorrect symbol or incorrect application of a symbol can result in unnecessary manufacturing costs or even the scrapping of a component.

5.10 Types of engineering drawings

To save time in the drawing office, most companies adopt a standardized and pre-printed drawing sheet as shown in Fig. 5.18 if manual drawing is still used. The layout and content will vary from company to company but, generally, such sheets will provide the following information:

- The drawing number and title.
- The projection used (first angle or third angle).
- The scale.
- The general tolerance.
- The material specification.
- Warning notes.

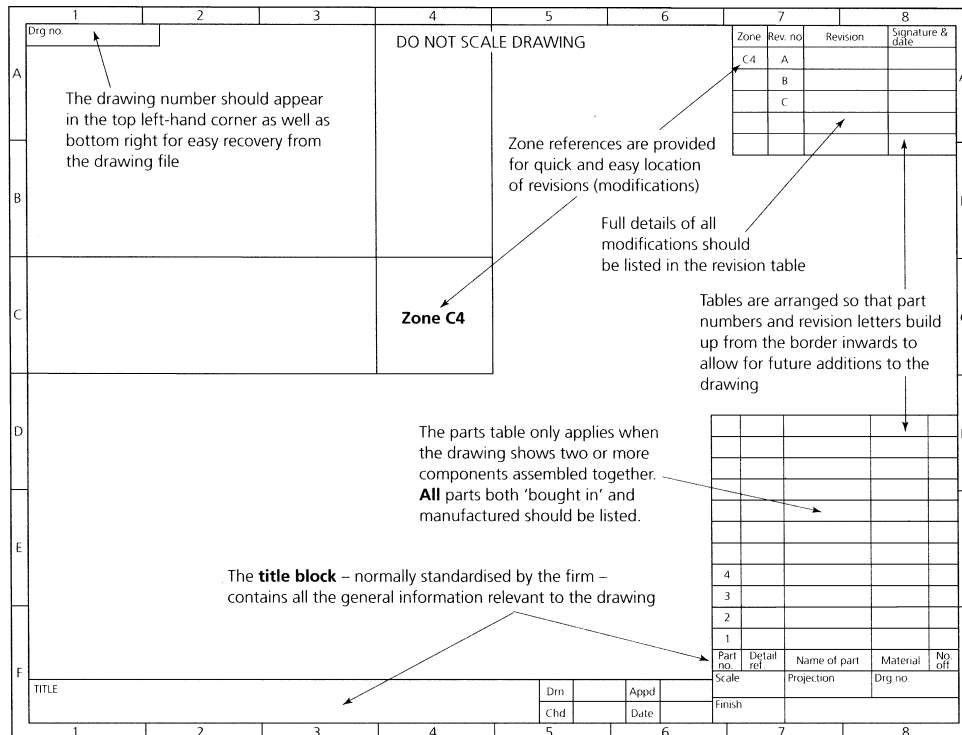


Figure 5.18 Layout of drawing sheet

- Any corrections or revisions, the date these were made, and the zone in which they occur.
- Special notes concerning, for example, heat treatment, decorative, corrosion resistant or other surface finishes.

If manual drawing is to be used then a pre-printed tracing sheet on tracing paper or plastic sheet will be used. The latter is more expensive but it is more durable if many copies of the drawing are required over an extended period of time. Modern drawing offices now use CAD systems. The standard layout is saved in the memory of the computer as a 'template' and can be called up by a keystroke whenever a drawing is to be made.

5.10.1 General arrangement drawings

An example of a *general arrangement* (GA) drawing is shown in Fig. 5.19. It shows all the components correctly assembled, and lists all the parts required. For those parts that will be 'bought in', it will state the maker and catalogue reference for the benefit of the purchasing department. For those parts to be made in the factory, the detail drawing numbers will be provided together with the material specification and the quantity of parts required. General arrangement drawings do not

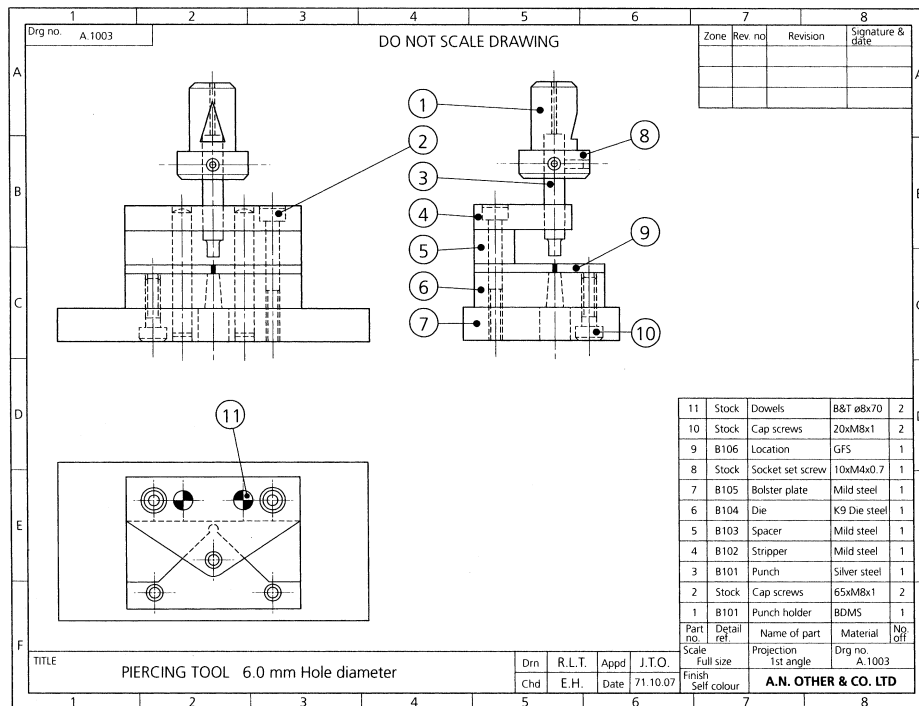


Figure 5.19 General arrangement drawing

normally carry dimensions except, occasionally, overall dimensions for reference only.

5.10.2 Detail drawings

Detail drawings provide all the details required to make a component, and an example is shown in Fig. 5.20. A detail drawing not only shows the shape of the component but also its size and the tolerances within which it must be manufactured. In this example it also states the materials to be used and the heat treatment of the punch. Similar detail drawings would be required for all the other components shown in the general arrangement drawing.

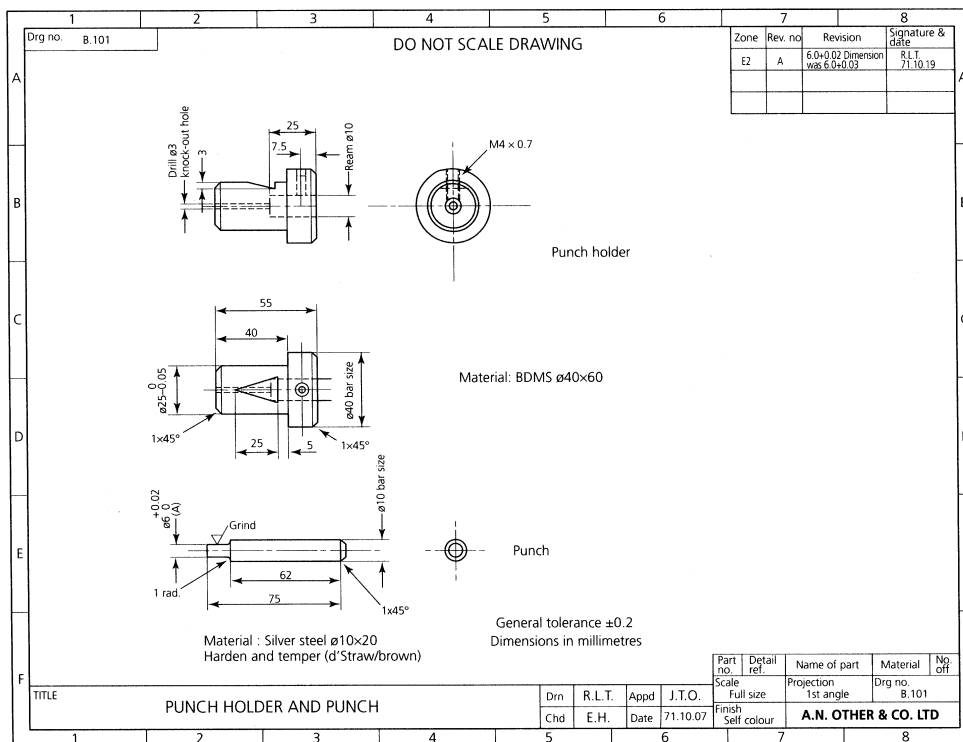
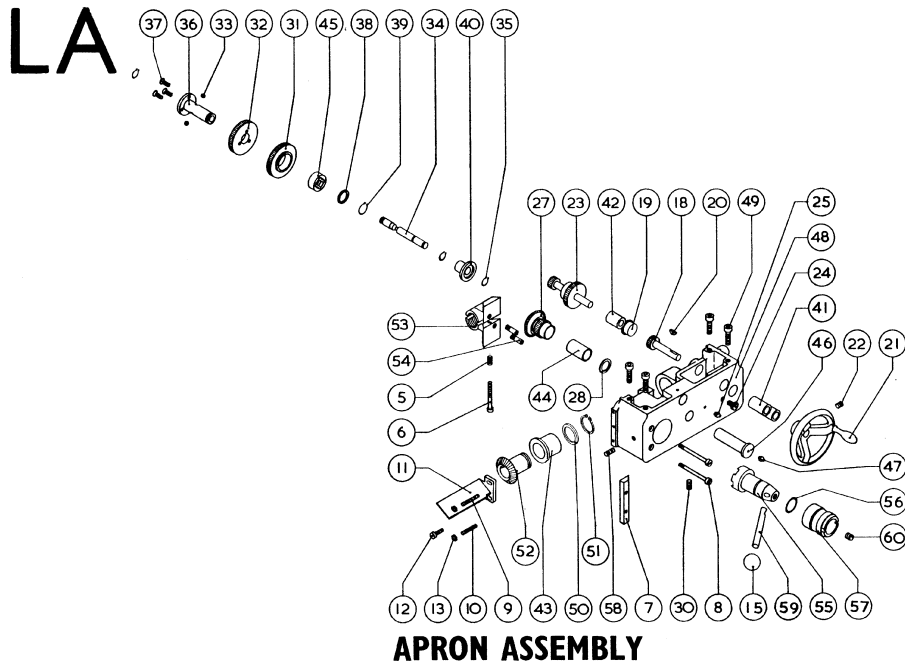


Figure 5.20 Detail drawing

5.10.3 Exploded (assembly) drawings

You will find these mainly in the service manuals for machines and similar devices. They show the components in the correct relationship to each other and the stock reference number for each component to facilitate the ordering of spare parts. An example is shown in Fig. 5.21.



SECTION LA

APRON ASSEMBLY

Drg. Ref.	Part No.	Description	No. Off/Mc.	Drg. Ref.	Part No.	Description	No. Off/Mc.
LA5	A4729	Spring—Leadscrew Nut	1	LA38	A9782	Washer—Drive Shaft	1
LA6	A4729	Cap Hd. Screw—Leadscrew Nut (2 B.A. x 1½")	1	LA39	A9782	Circlip—Drive Shaft (Anderton 1400—¾")	1
LA7	A2082	Gib Strip—Leadscrew Nut	1	LA40	A9208	Knob Operating Spindle	1
LA8	A9193	Ch. Hd. Screw—Strip Securing	2	LA41	A9210	'Oilite' Bush	2
LA9	A9194	Adjusting Screw—Gib Strip	1	LA42	A9211	'Oilite' Bush	1
LA10	A9195	Adjusting Screw—Gib Strip	1	LA43	A9212/1	'Oilite' Bush—Flanged	1
LA11	A9196	Leadscrew Guard	1	LA44	A7595	'Oilite' Bush	1
LA12	A9196	Hex. Hd. Set Screw (2 B.A. x ½")	1	LA45	A9220	Clutch Insert	1
LA13	A9196	Hex. Locknut (2 B.A.)	2	LA46	A9203/1	Stud—Gear Cluster	1
LA15	80002	Ball Knob (KB5/100)	1	LA47	65001	Oil Nipple (Tecalmit NC6057)	1
LA18	A9198	Hand Traverse Pinion	1	LA48	10025/1	Apron Assembly (includes LA41, LA42, LA43)	1
LA19	65004	Sealing Plug—Apron (AQ330/115)	1	LA49	A9203/1	Cap Screw (M6 x 1 x 25 mm)	4
LA20	70002	Woodruff Key (No. 404)	1	LA50	10217	Thrust Washer	1
LA21	A2087	Handwheel Assembly	1	LA51	10431	Circlip	1
LA22	A2087	Socket Set Screw (½" B.S.F. x ½") (Knurled Cup Point)	1	LA52	A9200/1	Bevel Pinion	1
LA23	A9199	Rack Pinion Assembly	1	LA53	A1975/3	Leadscrew Nut	1
LA24	A2531	Oil Level Plug	1	LA54	10508	Cam Peg	set
LA25	65000	Oil Nipple (Tecalmit NC6055)	1	LA55	10528	Cam	2
LA27	A9201	Bevel Gear Cluster Assembly (includes LA44)	1	LA56	65007	'O' Ring (BS/USA115)	1
LA28	A9202	Thrust Washer	1	LA57	10529	Eccentric Sleeve	1
LA30	A9202	Socket Set Screw (½" B.S.F. x ½") (Knurled Cup Point)	1	LA58	10529	Socket Set Screw (½" B.S.F. x ½", Half Dog Point)	1
LA31	A9204	Clutch Gear Assembly (includes LA45)	1	LA59	10530	Lever	1
LA32	A9205	Drive Gear	1	LA60	10530	Socket Set Screw (2 B.A. x ½", Cup Point)	1
LA33	73010	Ball—Clutch (5 mm ø)	2	LA61	10424	Guard Plate (not illustrated)	1
LA34	A9206	Operating Spindle	1				
LA35	A9207	Circlip (Anderton 1400—¾")	3				
LA36	A9207	Drive Shaft	1				
LA37	A9207	C's'k Hd. Socket Screw (2 B.A. x ¾")	3				

Figure 5.21 Exploded view and parts list (source: Myford Ltd)

5.11 Pictorial views

At the start of this chapter we introduced a pictorial drawing of a clamp. In fact it was in a style of drawing called isometric projection. It is now time to look at pictorial views in more detail starting with oblique projection.

5.11.1 Oblique projection

Figure 5.22 shows a simple component drawn in *oblique projection*. The component is positioned so that you can draw one face true to size and shape. The lines running 'into' the page are called *receding lines* and these are usually drawn at 45° to the front face as shown. To improve the proportions of the drawing and make it look more realistic, you draw the receding lines *half their true length*. For ease of drawing you should observe the following rules.

- Any curve or irregular face should be drawn true shape (front view). For example, a circle on a receding face would have to be constructed as an ellipse, whereas if it were positioned on the front face it could be drawn with compasses.
- Wherever possible, the longest side should be shown on the front, true view. This prevents violation of perspective and gives a more realistic appearance.
- For long circular objects such as shafts, the above two rules conflict. In this instance the circular section takes preference and should become the front view for ease of drawing, even though this results in the long axis receding.

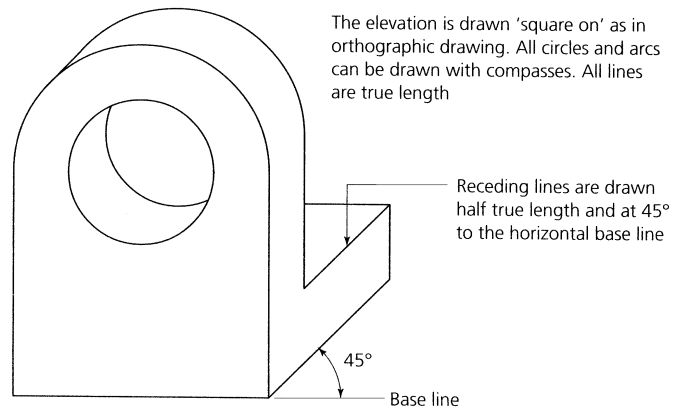


Figure 5.22 *Oblique drawing*

5.11.2 Isometric projection

The bracket shown in Fig. 5.23 is drawn in *isometric projection*. The isometric axes are drawn at 30° to the base line. To be strictly accurate you should draw these receding lines to isometric scale and only the

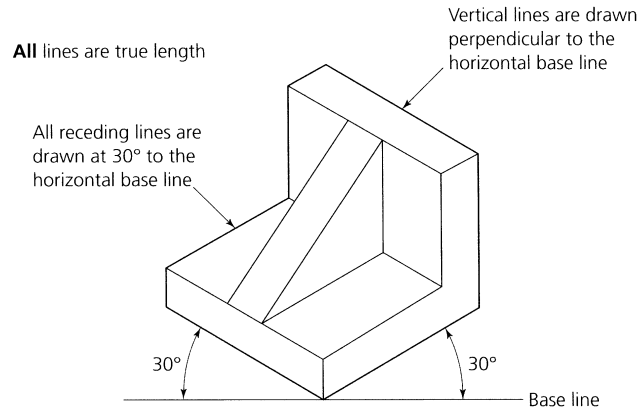
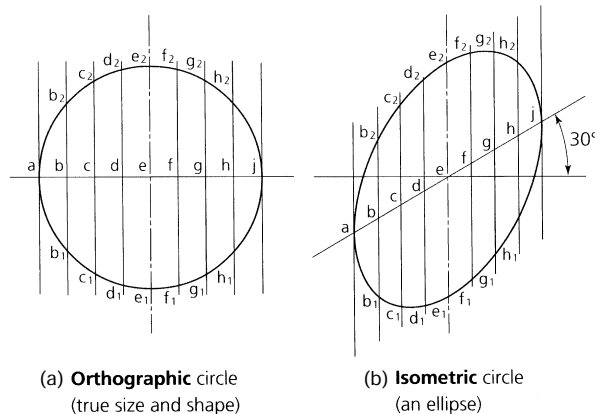


Figure 5.23 *Isometric drawing*

vertical lines are drawn to true scale. However, for all practical purposes, all the lines are drawn *true length* to save time.

Although isometric drawing produces a more pleasing representation than oblique drawing, it has the disadvantage that no curved profiles such as arcs, circles, radii, etc., can be drawn with compasses. All curved lines have to be constructed. You can do this by erecting a grid over the feature in orthographic projection as shown in Fig. 5.24(a). You then draw a grid of equal size where it is to appear on the isometric drawing. The points where the circle cuts the grid in the orthographic drawing are transferred to the isometric grid as shown in Fig. 5.24(b). You then draw a smooth curve through the points on the isometric grid and the circle appears as an ellipse.



1. Construct a grid over the true circle by dividing its centre line into an equal number of parts and erecting a perpendicular at each point.
2. Construct a similar grid on the isometric centre line.
3. Step off distances b_1 – b_2 , c_1 – c_2 , etc. on the isometric grid by transferring the corresponding distances from the true circle.
4. Draw a fair curve through the points plotted.

Figure 5.24 *Construction of isometric curves*

5.12 Sketching

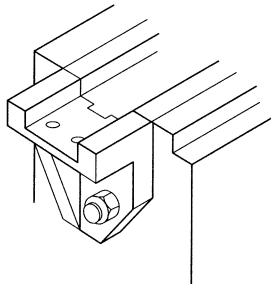


Figure 5.25 Bracket

The information given so far in this chapter should enable you, with practice, to correctly make and interpret formal engineering drawings. It is also important to be able to produce freehand sketches suitable for the manufacture of components. For example, the manufacture of replacement parts for maintenance purposes. The same rules apply as for formal drawings, except that you will be sketching freehand on any convenient, clean piece of paper.

5.12.1 Orthographic sketching

Figure 5.25 shows a bracket that has to be made and fitted to the end of a machine tool bed. Figure 5.26 shows the steps required to make a freehand orthographic sketch for the bracket. In fact it is a freehand detail drawing.

- Use a sheet of clean flat good quality paper of adequate size and an 'H' grade pencil. You also want a clean flat surface to draw on. A clipboard is handy.
- Paper faint ruled with squares is helpful as it gives you a guide for lines at right angles to each other.
- Now make outline sketches of the views you require using thin, faint lines.
- When you are satisfied with your initial sketches, draw in the outline more heavily and add any necessary details.
- When the basic sketch is complete check it for the omission of any essential details.
- Having completed the outline, you now have to add the dimensions. Use a rule or other instruments such as micrometer and vernier calipers to take the measurements you require and transfer them to the drawing. If the measurements are taken accurately and shown correctly on your sketch, your sketch does not have to be to scale. In any case a drawing should never be scaled since you cannot draw to the accuracy required for the manufacture of an engineering component.
- Make enlarged sketches of any small details that cannot be clearly shown in the main views.
- Although it is only a sketch for use once, it must incorporate all the rules, information and conventions discussed earlier in this chapter. Only then will the person making the component be able to make it correctly.

5.12.2 Pictorial sketching

Pictorial sketches can be in oblique projection or in isometric projection. Figure 5.27 shows you how to make a sketch in *oblique* projection.

1. Sketch 'boxes' to contain the outline of the finished drawing.

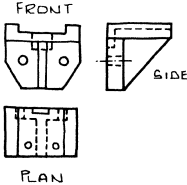
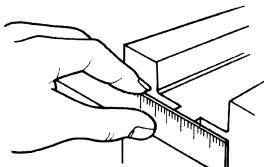
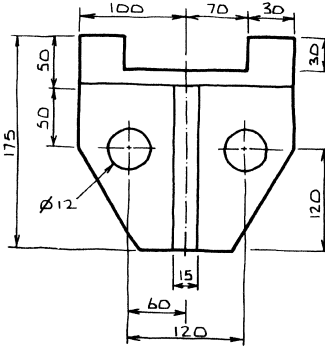
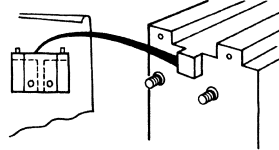
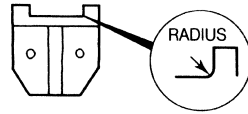
	<p>When making a sketch:</p> <ul style="list-style-type: none"> • Use cleanest paper available and a sharp pencil or ballpoint pen. Rest the work on a flat surface or support it firmly. The use of paper ruled with squares is helpful. • Attempt to keep the drawing as clean and clear as possible. • Make rough sketches to decide what views are necessary.
	<ul style="list-style-type: none"> • Take measurements and mark on sketch.
	<ul style="list-style-type: none"> • If measurements are taken accurately, and shown correctly, a freehand sketch need not be exactly in proportion. It must be clear and neat to prevent error in reading from it. Symbols used should adhere to BS 308.
	<ul style="list-style-type: none"> • When shapes are complete, check carefully against existing objects for omissions.
	<ul style="list-style-type: none"> • Make an enlarged sketch of detail where necessary.

Figure 5.26 *Orthographic sketching*

2. Lightly sketch in the details of the component or assembly being drawn.
3. Go over the outline more heavily to make it stand out.
4. Remove any construction lines that may cause confusion.
5. Add dimensions as required.

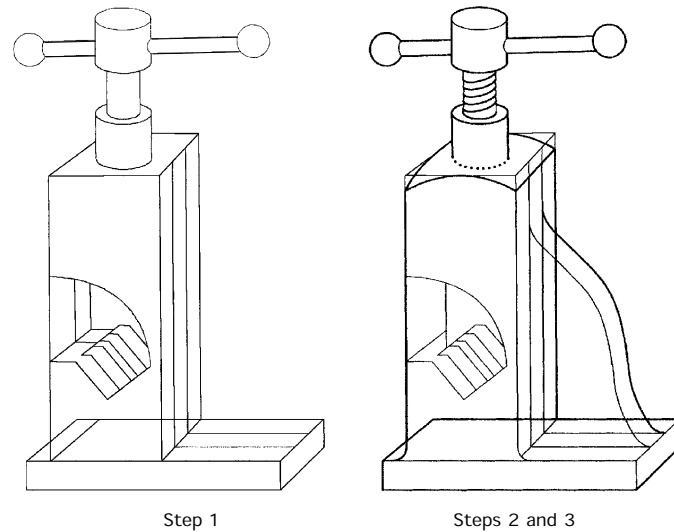


Figure 5.27 Pictorial sketching (oblique): Step 1 – general outlines (very faint); Steps – add details and line in

Figure 5.28 shows you how to make a sketch of a two jaw chuck in *isometric* projection. The technique is similar to that used for the previous, oblique sketch. However, the initial outline ‘boxes’ are drawn in isometric projection.

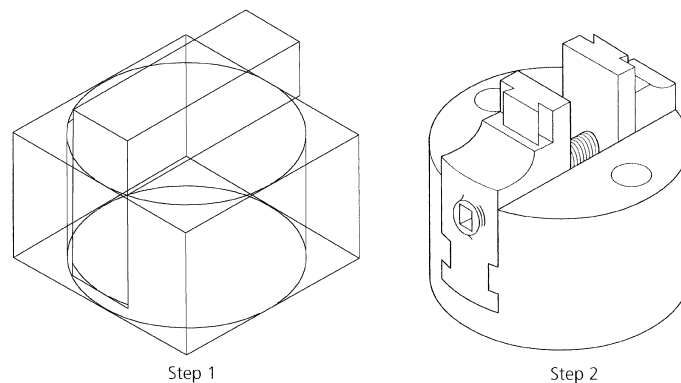


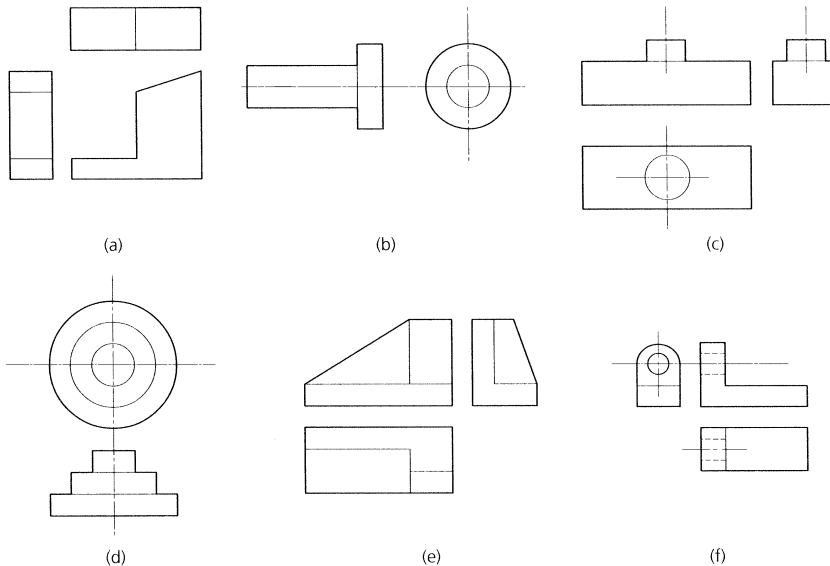
Figure 5.28 Pictorial sketching (isometric): Step 1 – general outlines (very faint); Step 2 – add details and line in

1. Sketch the outline boxes in isometric projection as shown.
2. Now sketch the curves using faint lines. Remember that in isometric projection these will be ellipses or parts of ellipses. A template may be helpful.

3. Add any detail that is required.
4. Finally line in the outline more heavily and remove any construction lines that may cause confusion.
5. Add dimensions as required.

Exercises**5.1** *First and third angle projection*

- (a) State which of the examples shown in Fig. 5.29 are in FIRST or THIRD angle projection.

**Figure 5.29** *Exercise 5.1(a)*

- (b) Copy and complete the examples shown in Fig. 5.30. The projection symbol is placed below each example for your guidance. (*Note*: Sometimes complete views are missing, sometimes only lines and features.)

5.2 *Types of line*

- (a) Copy and complete Fig. 5.31.
- (b) With the aid of a sketch show what is meant by the terms:
- (i) dimension line;
 - (ii) leader line;
 - (iii) projection line.

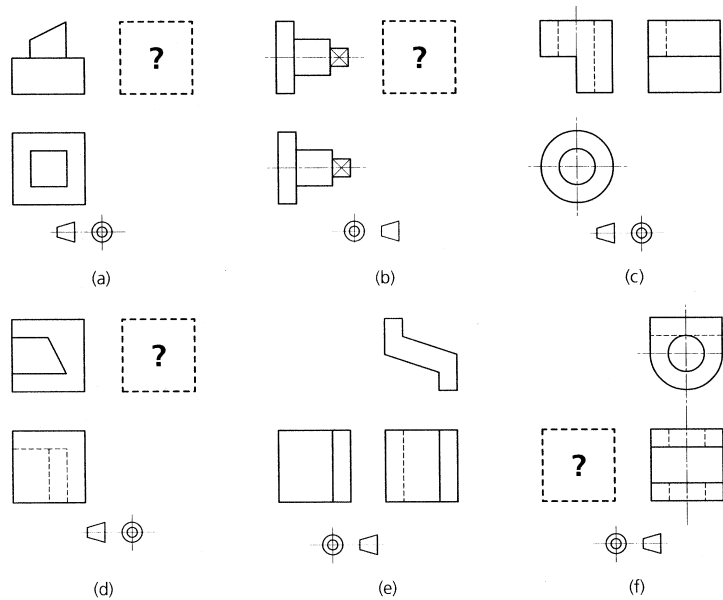


Figure 5.30 Exercise 5.1(b)

Line	Description	Application
	Continuous bold	
	Continuous fine	
		Limit of partial view
	Fine short dashes	
		Centre lines
	Fine chain, bold at ends and changes of direction	Cutting planes

Figure 5.31 Exercise 5.2(a)

- (c) With reference to exercise (b):
- (i) state the type of line that should be used;
 - (ii) indicate on your sketch where a short extension is required and where a small gap is required.

5.3 Dimensioning

- (a) With the aid of sketches show how a simple component can be dimensioned from:
- (i) a pair of mutually perpendicular datum edges (or surfaces);
 - (ii) a datum line;
 - (iii) a datum point.
- (b) With the aid of sketches show how you should dimension the following features:
- (i) a circle (show FOUR methods of dimensioning and use the diameter symbol);
 - (ii) a radius (both convex and concave);
 - (iii) an angle or chamfer.
- (c) Figure 5.32 shows a number of abbreviations found on engineering drawings. Copy and complete the figure.

Name	Abbreviation	Sketch
	S'FACE	
	C'BORE	
	C'SK	

Figure 5.32 *Exercise 5.3(c)***5.4 Conventions**

- (a) Give TWO reasons why standard conventions are used on engineering drawings.
- (b) Figure 5.33 relates to some commonly used drawing conventions. Copy and complete the figure.

5.5 Sectioning

Sketch a section through the component shown in Fig. 5.34 on the cutting planes XX and YY.

5.6 Pictorial views

- (a) Figure 5.35 shows a simple workpiece. Sketch it in:
- (i) oblique projection;
 - (ii) isometric projection.
- (b) Figure 5.36 shows a component in isometric projection. Sketch it full size in:
- (i) *first angle* orthographic projection with the necessary dimensions so that your sketch can be used as a detail drawing for the manufacture of the component;

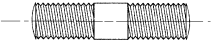
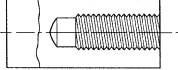
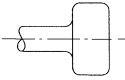
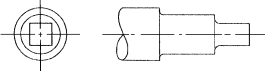
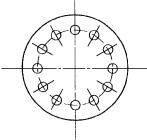
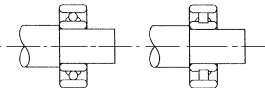
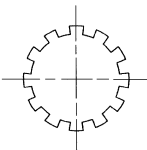
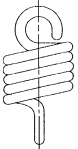
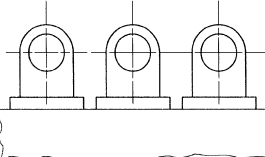
Title	Subject	Convention
External screw threads (detail)		
Internal screw threads (detail)		
Diamond knurling		
Square on shaft		
Holes on circular pitch		
Ball and roller bearings		
Splined shafts		
Cylindrical tension spring		
Repeated parts		

Figure 5.33 Exercise 5.4(b)

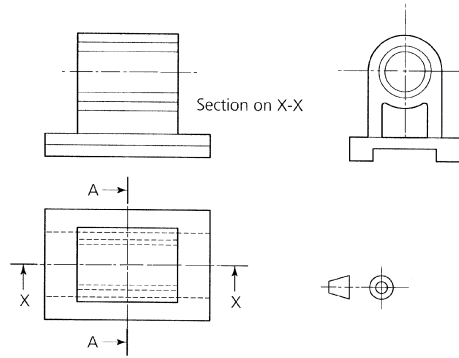


Figure 5.34 *Exercise 5.5*

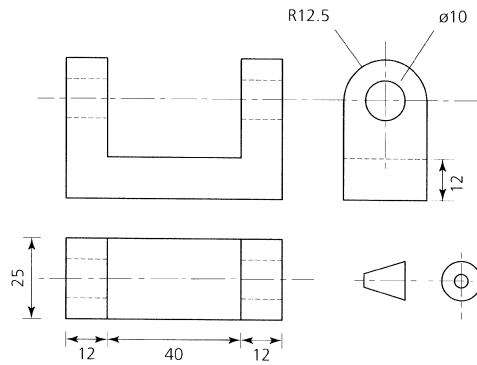


Figure 5.35 *Exercise 5.6(a)*

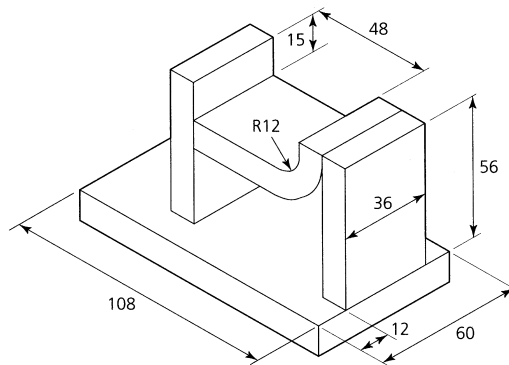


Figure 5.36 *Exercise 5.6(b)*

- (ii) *third angle* orthographic projection with the necessary dimensions so that your sketch can be used as a detail drawing for the manufacture of the component.

6 Measuring

When you have read this chapter you should understand:

- What is meant by linear measurement.
- How to make linear measurements.
- What is meant by angular measurement.
- How to make angular measurements.
- The factors affecting accuracy of measurement.
- The terminology of measurement.
- The general rules for accurate measurement.
- How to measure workpieces having square, rectangular, circular and irregular-shaped sections.

6.1 Introduction Measuring can be considered to be the most important process in engineering. Without the ability to measure accurately, we cannot:

- Mark out components as described in Chapter 7.
- Set up machines correctly to produce components to the required size and shape.
- Check components whilst we are making them to ensure that they finally end up the correct size and shape.
- Inspect finished components to make sure that they have been correctly manufactured.

6.2 Linear measurement When you measure length, you measure the shortest distance in a straight line between two points, lines or faces. It doesn't matter what you call this distance (width, thickness, height, breadth, depth or diameter) it is still a measurement of length. There are two systems for the measurement of length, the *end system* of measurement and the *line system* of measurement. The end system of measurement refers to the measurement of distance between two faces of a component, whilst the line system of measurement refers to the measurement of the distance between two lines or marks on a surface. No matter what system is used, measurement of length is the comparison of the size of a component or a feature of a component and a known standard of length. In a workshop this may be a steel rule or a micrometer caliper, for example. These, in turn, are directly related to fundamental international standards of length.

In order for world trade to flourish it is necessary for national standards to be interchangeable or 'harmonized'. In the UK this is the responsibility

of the British Standards Institution (BSI) which works in conjunction with the International Standards Organization (ISO) and European Community standards committees. Such international standardization is essential to ensure the *interchangeability* of components and equipment manufactured in different countries. The units of the *Système Internationale d'Unites* (SI) are now used throughout the world.

The fundamental unit of length is the *metre* and, currently, this is defined as:

*the length of a path travelled by laser light in 1/299 792 458 seconds.
The light being realized through the use of an iodine stabilized
helium–neon laser.*

The international standard yard is defined as 0.9144 metre. Whilst units based on the metre are used worldwide, units based on the international standard yard are mainly used in the UK and the USA.

6.1.1 Steel rules (use of)

The steel rule is frequently used in workshops for measuring components of limited accuracy quickly. The quickness and ease with which it can be used, coupled with its low cost, makes it a popular and widely used measuring device. Metric rules may be obtained in various lengths from 150 mm to 1000 mm (1 metre). Imperial rules may be obtained in various lengths from 6 inch to 36 inch (1 yard). It is convenient to use a rule engraved in both systems, one system on the front and the other on the back.

Steel rules may be 'rigid' or 'flexible' depending upon their thickness and the 'temper' of the steel used in their manufacture. When choosing a steel rule the following points should be looked for. It should be:

- Made from hardened and tempered, corrosion resistant spring steel.
- Engine divided. That is, the graduations should be precision engraved into the surface of the metal.
- Ground on the edges so that it can be used as a straight edge when scribing lines or testing a surface for flatness.
- Ground on one end so that this end can be used as the zero datum when taking measurements from a shoulder.
- Satin chrome finished so as to reduce glare and make the rule easier to read, also to prevent corrosion.

No matter how accurately a rule is made, all measurements made with a rule are of limited accuracy. This is because of the difficulty of sighting the graduations in line with the feature being measured. Some ways of minimizing sighting errors are shown in Fig. 6.1.

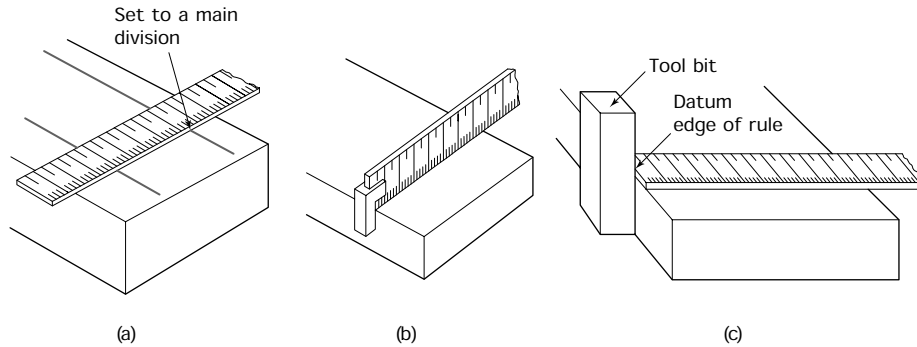


Figure 6.1 Use of a rule – measuring the distance between: (a) two scribed lines; (b) two faces using a hook rule; (c) two faces using a steel rule and a tool bit as an abutment

When using a rule to make direct measurements, as in Fig. 6.1(a), the accuracy of measurement depends upon the *visual alignment* of a mark or surface on the work with the corresponding graduation on the rule. This may appear relatively simple but, in practice, errors can very easily occur. These errors can be minimized by using a thin rule and keeping your eyes directly above and at 90° to the mark on the work. If you look at the work and the rule from an angle, you will get a false reading. This is known as *parallax* error. Figures 6.1(b) and 6.1(c) show two ways of aligning the datum (zero) end of the rule with the edge of the component to eliminate one source of sighting error.

6.1.2 Steel rule (care of)

A good rule should be looked after carefully to prevent wear and damage to its edges and to the datum end. It should never be used as a scraper or as a screwdriver, and it should never be used to clean the swarf out of the T-slots in the tables of machine tools. After use, plain steel rules should be lightly oiled to prevent rusting. Dulling of the surfaces will make the scales difficult to read. There is no need to oil satin-chrome plated rules, just wipe them clean.

6.1.3 Line and end measurement

Linear distances sometimes have to be measured between two lines, sometimes between two surfaces and sometimes between a combination of line and surface. Measurement between two lines is called *line measurement*. Measurement between two surfaces is called *end measurement*. It is difficult to convert between end systems of measurement and line systems of measurement and vice versa. For example, a rule (which is a line system measuring device) is not convenient for the direct measurement of distances between two edges. Similarly, a micrometer (which is an end system measuring device) would be equally inconvenient if used to measure the distance between two lines. The measuring device must always be chosen to suit the job in hand.

6.1.4 Calipers and their use

Calipers are used in conjunction with a rule so as to transfer the distance across or between the faces of a component in such a way as to reduce sighting errors. That is, to convert from end measurement to line measurement. Firm-joint calipers are usually used in the larger sizes and spring-joint calipers are used for fine work. Examples of internal and external calipers of both types are shown in Fig. 6.2 together with examples of their uses.

The accurate use of calipers depends upon practice, experience, and a highly developed sense of feel. When using calipers, the following rules should be observed:

- Hold the caliper gently and near the joint.
- Hold the caliper square (at right angles) to the work.
- No force should be used to 'spring' the caliper over the work. Contact should only just be felt.
- The caliper should be handled and laid down gently to avoid disturbing the setting.
- Lathe work should be *stationary* when taking measurements. This is essential for *safety* and *accuracy*.

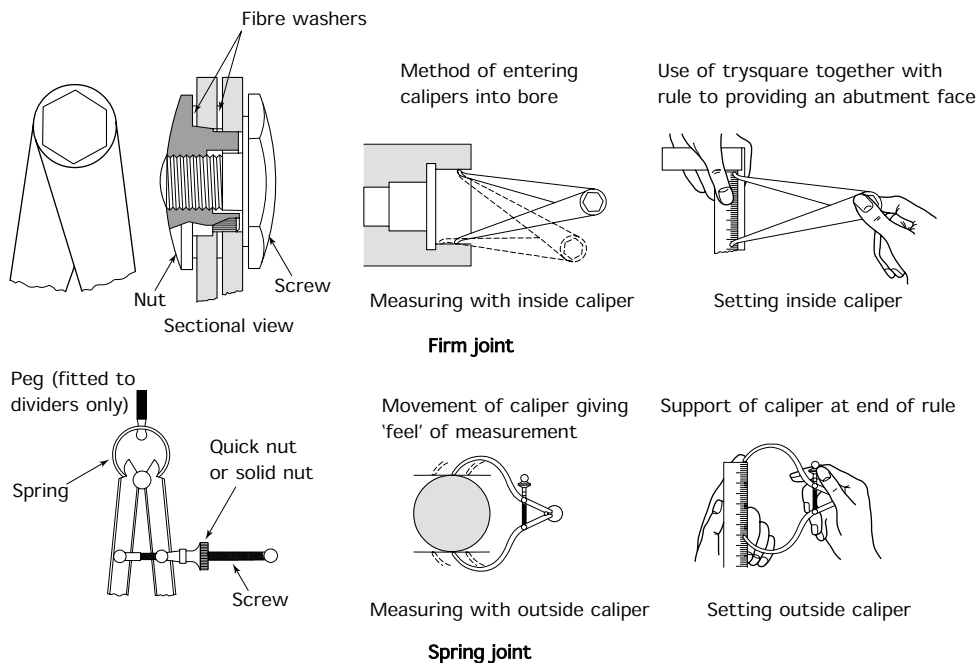
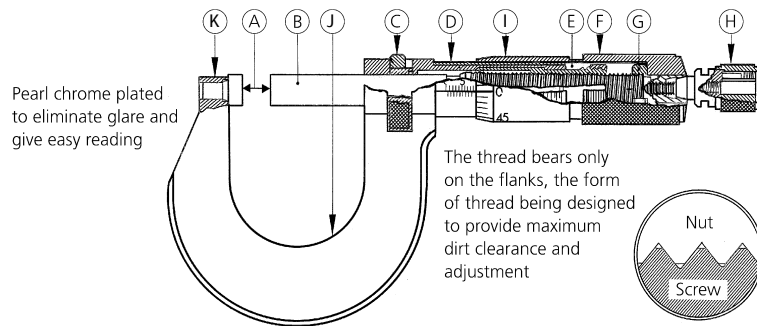


Figure 6.2 Construction and use of calipers

6.1.5 The micrometer caliper (use of)

Most engineering work has to be measured to much greater accuracy than it is possible to achieve with a rule, even when aided by the use of calipers. To achieve this greater precision, measuring equipment of greater accuracy and sensitivity has to be used. One of the most familiar measuring instruments used in engineering workshops is the *micrometer caliper*. This is frequently referred to as a 'micrometer' or simply a 'mike'. The constructional details of a typical micrometer caliper are shown in Fig. 6.3.



- A Spindle and anvil faces – Glass hard and optically flat, also available with tungsten carbide faces
- B Spindle – Thread ground and made from alloy steel, hardened throughout, and stabilised
- C Locknut – Effective at any position. Spindle retained in perfect alignment
- D Barrel – Adjustable for zero setting. Accurately divided and clearly marked, pearl chrome plated
- E Main nut – Length of thread ensures long working life
- F Screw adjusting nut – For effective adjustment of main nut
- G Thimble adjusting nut – Controls position of thimble
- H Ratchet – Ensures a constant measuring pressure
- I Thimble – Accurately divided and every graduation clearly numbered
- J Steel frame – Drop forged
- K Anvil end– Cutaway frame facilitates usage in narrow slots

Figure 6.3 *The micrometer caliper (source: Moore and Wright)*

The operation of this instrument depends upon the principle that the distance a nut moves along a screw is proportional to the number of revolutions made by the nut and the lead of the screw thread. Therefore by controlling the number of complete revolutions made by the nut and the fractions of a revolution made by a nut, the distance it moves along the screw can be accurately controlled. It does not matter whether the nut rotates on the screw or the screw rotates in the nut, the principle of operation still holds good.

In a micrometer caliper, the screw thread is rotated by the thimble which has a scale that indicates the partial revolutions. The barrel of the instrument has a scale which indicates the 'whole' revolutions. In a standard metric micrometer caliper the screw has a lead of 0.5 millimetre and the thimble and barrel are graduated as in Fig. 6.4.

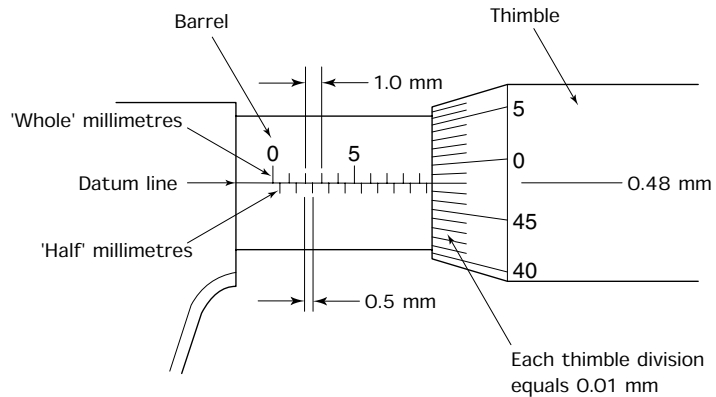


Figure 6.4 *Micrometer scales (metric)*

Since the lead of the screw of a standard metric micrometer is 0.5 millimetre and the barrel divisions are 0.5 millimetre apart, one revolution of the thimble moves the thimble along the barrel a distance of one barrel division (0.5 mm). The barrel divisions are placed on alternate sides of the datum line for clarity. Further, since the thimble has 50 divisions and one revolution of the thimble equals 0.5 millimetre, then a movement of *one thimble division* equals: 0.5 millimetre/50 divisions = 0.01 millimetre.

A metric micrometer caliper reading is given by:

- The largest visible 'whole' millimetre graduation visible on the barrel, *plus*
- The next 'half' millimetre graduation, if this is visible, *plus*
- The thimble division coincident with the datum line.

Therefore the micrometer scales shown in Fig. 6.5 read as follows:

$$\begin{aligned}
 9 \text{ 'whole' millimetres} &= 9.00 \\
 1 \text{ 'half' millimetre} &= 0.50 \\
 48 \text{ hundredths of a millimetre} &= \underline{0.48} \\
 &= \underline{\underline{9.98}} \text{ mm}
 \end{aligned}$$

Figure 6.5 shows the scales for a micrometer graduated in 'inch' units. The micrometer screw has 40 TPI (threads per inch), therefore the lead of the screw is 1/40 inch (0.025 inch). The barrel graduations are 1/10 inch subdivided into 4. Therefore each subdivision is 1/40 inch (0.025 inch) and represents one revolution of the thimble. The thimble carries 25 graduations. Therefore one thimble graduation equals a movement of 0.025 inch/25 = 0.001 inch. This is one-thousandth part of an inch and

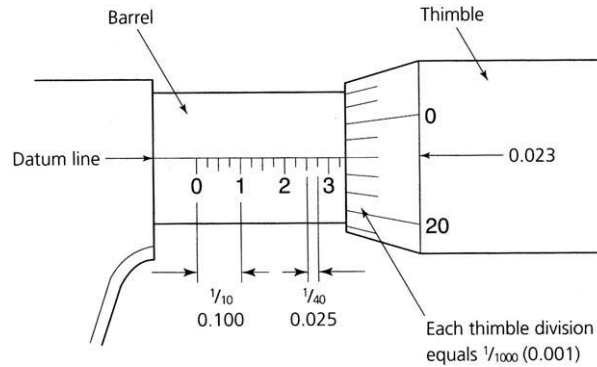


Figure 6.5 *Micrometer scales (English)*

is often referred to by engineers as a ‘thou’. Thus 0.015 inch could be referred to as 15 ‘thou’.

An inch micrometer reading is given by:

- The largest visible 1/10 inch (0.1 inch) division, *plus*
- The largest visible 1/40 inch (0.025 inch) division, *plus*
- The thimble division coincident with the datum line.

Therefore the micrometer scales shown in Fig. 6.6 read as follows:

$$3 \text{ tenths of an inch} = 0.300$$

$$1 \text{ fortieth of an inch} = 0.025$$

$$23 \text{ thousandths of an inch} = \underline{0.023}$$

$$= \underline{\underline{0.348 \text{ inch}}}$$

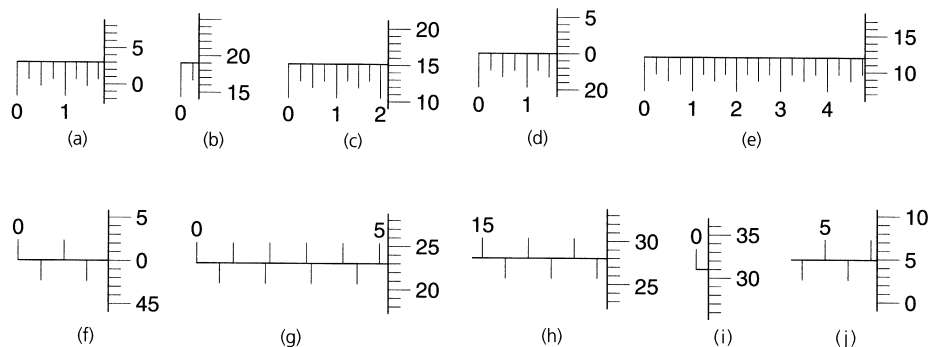


Figure 6.6 *Micrometer caliper reading exercises*

Figure 6.6 shows some further examples of English (inch) and metric micrometer scales and their readings. Try to work them out for yourself before looking up the correct readings at the end of this chapter (page 186).

6.1.6 Micrometer caliper (care of)

Unless a micrometer caliper is properly looked after it will soon lose its initial accuracy. To maintain this accuracy you should observe the following precautions:

- Wipe the work and the anvils of the micrometer clean before making a measurement.
- Do not use excessive measuring pressure, two ‘clicks’ of the ratchet are sufficient.
- Do not leave the anvil faces in contact when not in use.
- When machining, stop the machine before making a measurement. Attempting to make a measurement with the machine working can ruin the instrument and also lead to a serious accident. This rule applies to all measuring instruments and all machines.

Although easy to read and convenient to use, micrometer calipers have two disadvantages:

- A limited range of only 25 millimetres. Thus a range of micrometers is required, for example: 0–25 millimetres, 25–50 millimetres, 50–75 millimetres, and so on.
- Separate micrometers are required for internal and external measurements. The micrometer caliper so far described can be used only for external measurements.

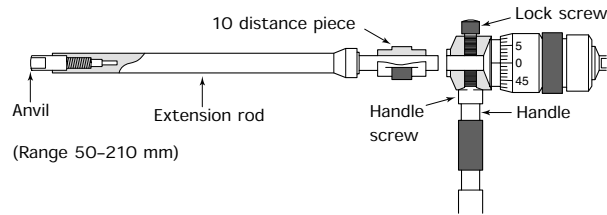
6.1.7 Internal micrometer

An internal micrometer is shown in Fig. 6.7(a). It is used for measuring bore diameters and slot widths from 50 millimetres to 210 millimetres. For any one extension rod its measuring range is 20 millimetres. A range of extension rods in stepped lengths is provided in the case with the measuring head. It suffers from two important limitations.

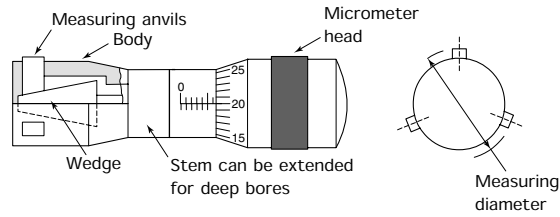
- It cannot be used to measure small holes less than 50 millimetres diameter.
- It cannot be easily adjusted once it is in the hole and this affects the accuracy of contact ‘feel’ that can be obtained.

6.1.8 Micrometer cylinder gauge

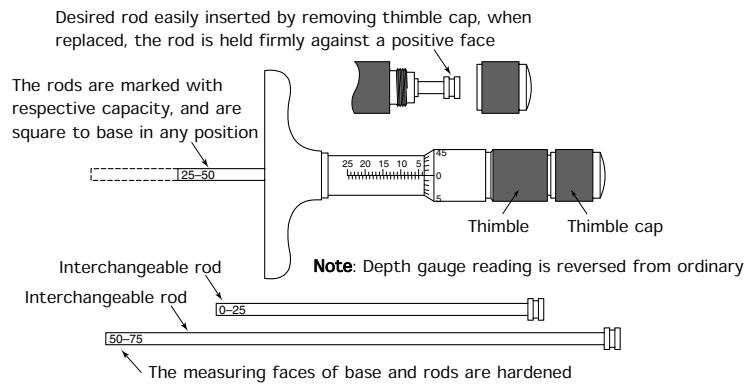
Figure 6.7(b) shows the principle of the micrometer cylinder gauge. It is used for measuring the diameters of holes to a high degree of accuracy. It uses a micrometer-controlled wedge to expand three equi-spaced anvils



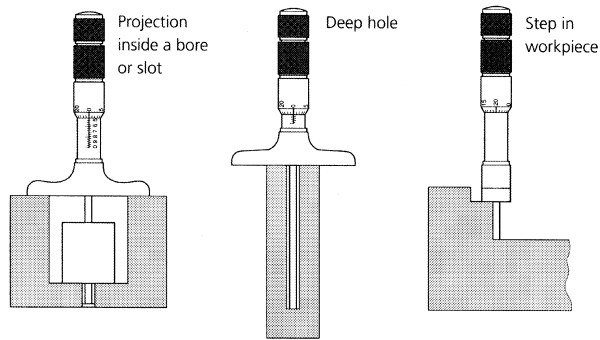
(a)



(b)



(c)



(d)

Figure 6.7 Further applications of the micrometer principle: (a) the internal micrometer; (b) the micrometer cylinder gauge; (c) micrometer depth gauge; (d) application of the micrometer depth gauge

until they touch the walls of the bore. Unfortunately it has only a limited measuring range and the range cannot be extended by the use of extension rods (see internal micrometer). A separate instrument has to be used for each range of hole sizes.

6.1.9 Depth micrometer

This is used for measuring the depth of holes and slots. You must take care when using a depth micrometer because its scales are reversed when compared with the familiar micrometer caliper. Also the measuring pressure tends to lift the micrometer off its seating. A depth micrometer is shown in Fig. 6.7(c). The measuring range is 25 millimetres for any given rods. Typical rods give a range of 0 to 25 mm, 25 to 50 mm, 50 to 75 mm. Some applications of a depth micrometer are shown in Fig. 6.7(d).

6.1.10 Vernier calipers

Although more cumbersome to use and rather more difficult to read, the vernier caliper has three main advantages over the micrometer caliper.

- One instrument can be used for measurements ranging over the full length of its main (beam) scale. Figure 6.8(a) shows a vernier caliper.
- It can be used for both internal and external measurements as shown in Fig. 6.8(b). Remember that for internal measurements you have to add the combined thickness of the jaws to the scale readings.

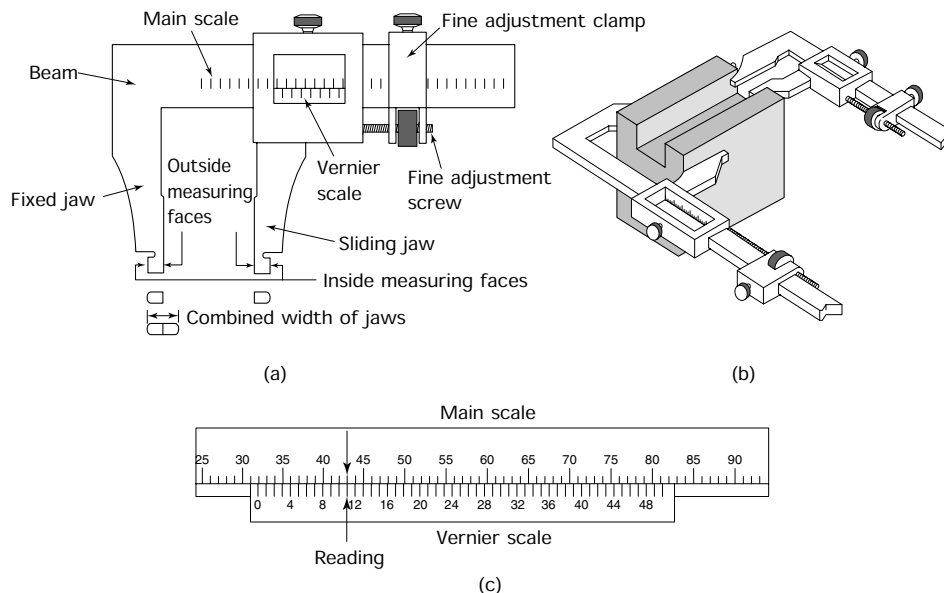


Figure 6.8 *The vernier caliper: (a) construction; (b) use; (c) vernier scale (50 divisions)*

- One instrument can be used for taking measurements in both inch units and in metric dimensional systems.

The measuring accuracy of a vernier caliper tends to be of a lower order than that obtainable with a micrometer caliper because:

- It is difficult to obtain a correct ‘feel’ with this instrument due to its size and weight.
- The scales can be difficult to read accurately even with a magnifying glass.

All vernier type instruments have two accurately engraved scales. A main scale marked in standard increments of measurement like a rule, and a vernier scale that slides along the main scale. This vernier scale is marked with divisions whose increments are slightly smaller than those of the main scale. Some vernier calipers are engraved with both inch and millimetre scales.

In the example shown in Fig. 6.8(c) the main scale is marked off in 1.00 mm increments, whilst the vernier scale has 50 divisions marked off in 0.98 mm increments. This enables you to read the instrument to an accuracy of $1.00 - 0.98 = 0.02$ mm. The reading is obtained as follows:

- Note how far the zero of the vernier scale has moved along the main scale (32 ‘whole’ millimetres in this example).
- Note the vernier reading where the vernier and main scale divisions coincide (11 divisions in this example). You then multiply the 11 divisions by 0.02 mm which gives 0.22 mm.
- Add these two readings together:

$$32 \text{ ‘whole’ millimetres} = 32.00 \text{ mm plus}$$

$$11 \text{ vernier divisions} = 00.22 \text{ mm}$$

thus the reading shown in Fig. 6.9(c) = 32.22 mm

Always check the scales before use as there are other systems available and not all vernier scales have 50 increments. This is particularly the case in some cheap instruments. Also check that the instrument reads zero when the jaws are closed. If not, then the instrument has been strained and will not give a correct reading. There is no means of correcting this error and the instrument must be scrapped. Since they are expensive, it is essential to treat them with care. Figures 6.9 and 6.10 show some additional vernier-caliper scales in metric and inch units. Try to work them out for yourself before looking at the correct readings given at the end of this chapter (page 186).

As for all measuring instruments vernier calipers must be treated with care and cleaned before and after use. They should always be kept in the case provided. This not only protects the instrument from damage, it also supports the beam and prevents it from becoming distorted.

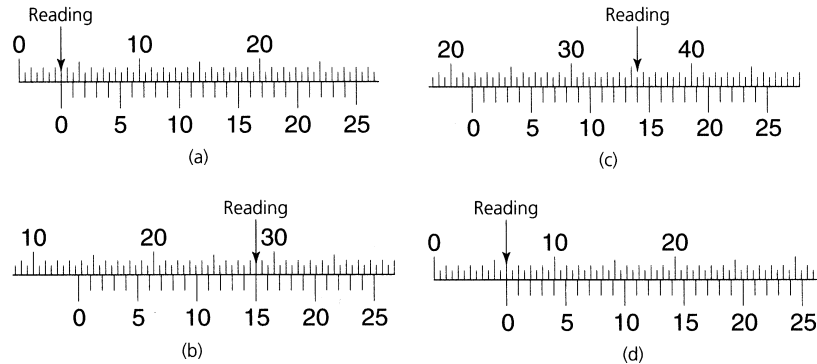


Figure 6.9 Vernier scales (metric) reading exercises. (Note: The scales shown in all these exercises have a reading accuracy of 0.02 mm)

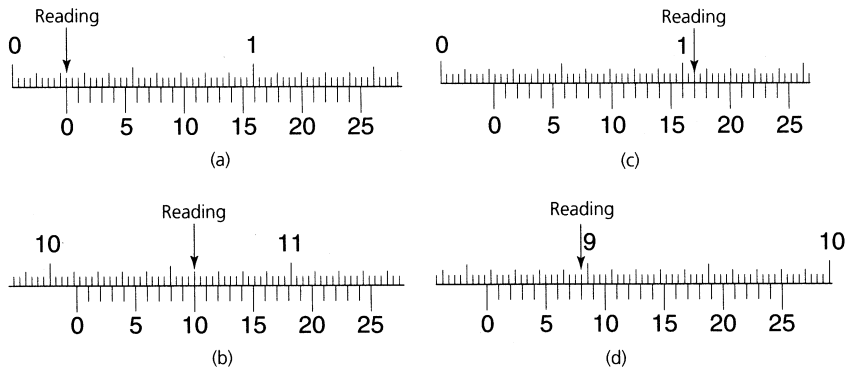


Figure 6.10 Vernier scales (English) reading exercises. (Note: The scales shown in all these exercises have a reading accuracy of 0.001 inch)

The vernier principle can also be applied to height gauges and to depth gauges. Some uses of the vernier height gauge are described later in this chapter and in Chapter 7.

6.1.11 Dial test indicators (DTI)

Dial test indicators are often referred to as ‘clocks’ because of the appearance of the dial and pointer. They measure the displacement of a plunger or stylus and indicate the magnitude of the displacement on a dial by means of a rotating pointer. There are two main types of dial test indicator.

Plunger type

This type of instrument relies upon a rack and pinion mechanism to change the linear (straight-line) movement of the plunger into rotary motion for the pointer. A gear train is used to magnify the movement

of the pointer. This type of instrument has a long plunger movement and is, therefore, fitted with a secondary scale to count the number of revolutions made by the main pointer. A large range of dial diameters and markings is available. Figure 6.11(a) shows a typical example of this type of instrument and Fig. 6.11(b) shows how you can use one of these instruments to make comparative measurements. Dial test indicators are also widely used for setting up workpieces, and aligning work holding devices on machine tools will be described in the later chapters of this book.

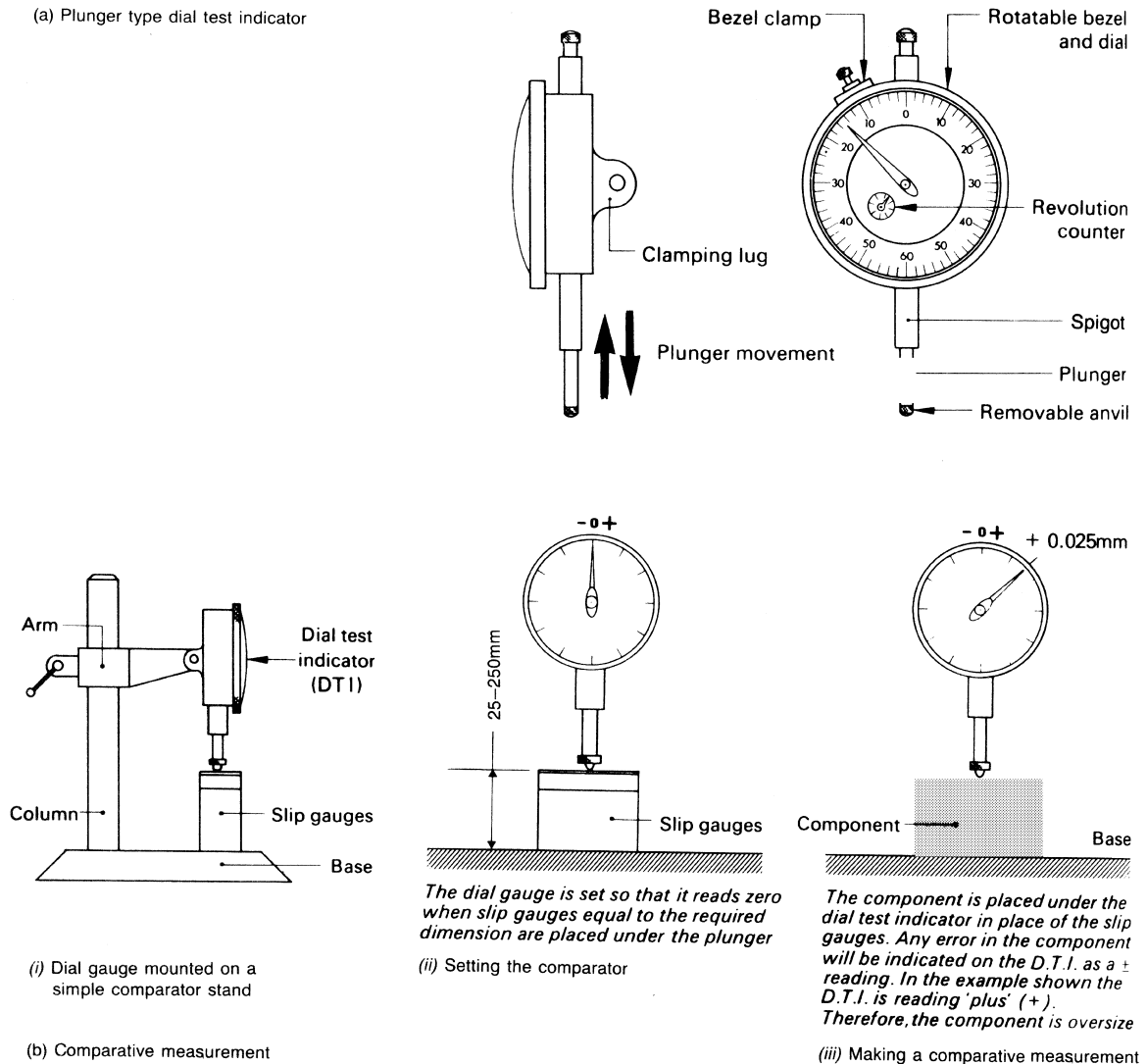


Figure 6.11 Dial test indicator (DTI): (a) plunger type; (b) comparative measurement

Lever type

This type of instrument uses a lever and scroll to magnify the displacement of the stylus. Compared with the plunger type, the lever type instrument has only a limited range of movement. However, it is extremely popular for inspection and machine setting because it is more compact and the scale is more conveniently positioned for these applications. Figure 6.12(a) shows a typical example of this type of instrument and Fig. 6.12(b) shows an application of its use. In this example the DTI is mounted on a vernier height gauge, and ensures that the measuring, contact, pressure over H_1 and H_2 is constant. That is, in each position, the vernier height gauge is adjusted until the DTI reads zero before the height gauge reading is taken.

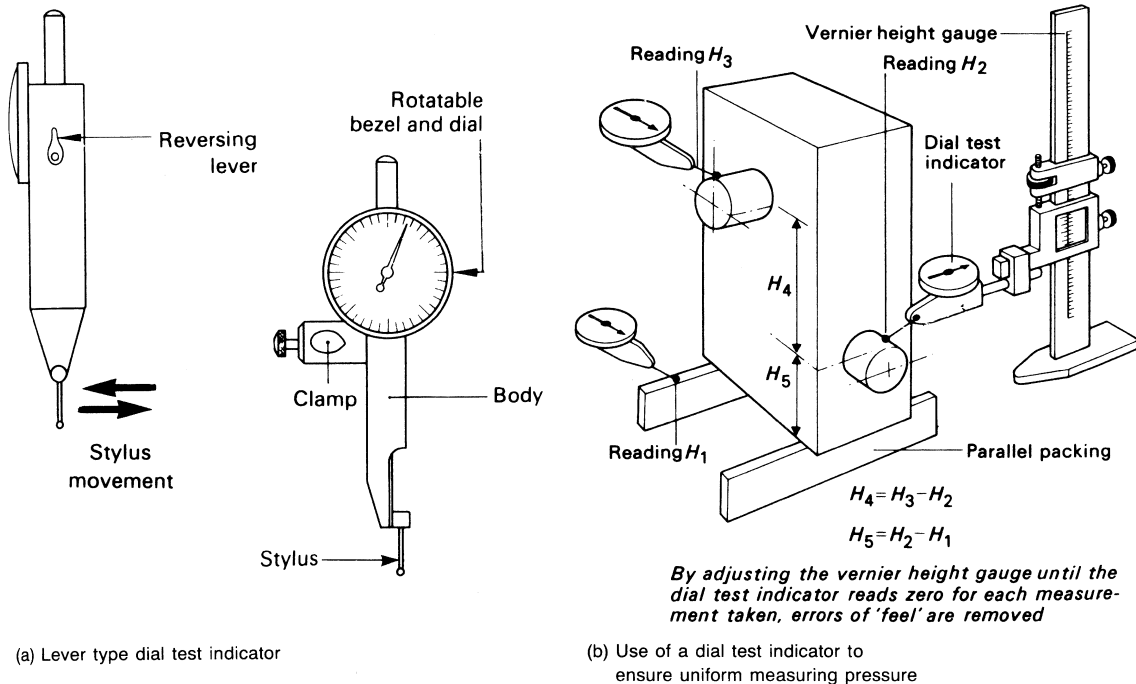


Figure 6.12 Dial test indicator (DTI): (a) lever type; (b) use of a DTI to ensure uniform measuring pressure – by adjusting the vernier height gauge until the dial test indicator reads zero for each measurement taken, errors of ‘feel’ are removed

6.1.12 Slip gauges

Slip gauges are blocks of steel that have been hardened and stabilized by heat treatment. They are ground and lapped to size to very high standards of accuracy and surface finish. They are the most accurate standards of length available for use in workshops. The accuracy and finish is so high that two or more slip gauges may be *wrung* together. The method

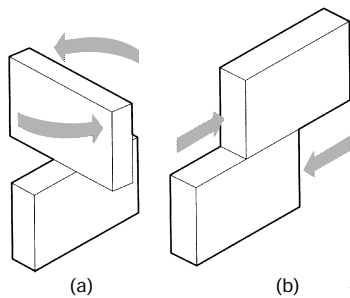


Figure 6.13 Slip gauges: (a) 'wring' the gauges together with a rotary motion to assemble them; (b) slide the gauges to separate them. (Note: Pulling the slip gauges apart damages the gauging faces)

of wringing slip gauges together is shown in Fig. 6.13(a). When correctly cleaned and wrung together, the individual slip gauges adhere to each other by molecular attraction and, if left like this for too long, a partial cold weld will take place. If this is allowed to occur, the gauging surfaces will be irreparably damaged when the blocks are separated. Therefore, immediately after use, the gauges should be separated carefully by sliding them apart as shown in Fig. 6.13(b). They should then be cleaned, smeared with petroleum jelly (vaseline) and returned to their case. A typical 78 piece metric set of slip gauges is listed in Table 6.1.

TABLE 6.1 Metric slip gauges

Range (mm)	Steps (mm)	Pieces
1.01 to 1.49	0.01	49
0.50 to 9.50	0.50	19
10.00 to 50.00	10.00	5
75.00 and 100.00	—	2
1.002 5	—	1
1.005	—	1
1.007 5	—	1

In addition, some sets also contain *protector slips* that are 2.50 mm thick and are made from a hard, wear resistant material such as tungsten carbide. These are added to the ends of the slip gauge stack to protect the other gauge blocks from wear. Allowance must be made for the thickness of the protector slips when they are used.

Slip gauges are wrung together to give a stack of the required dimension. In order to achieve the maximum accuracy the following precautions must be preserved:

- Use the minimum number of blocks.
- Wipe the measuring faces clean using a soft clean chamois leather.
- *Wring* the individual blocks together.

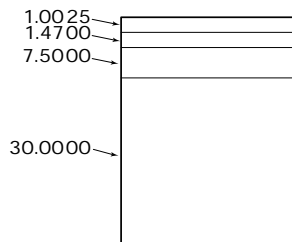


Figure 6.14 Building up slip gauges

Let's see how we can build up a stack of slip gauges to give a dimension of 39.9725 mm. This is shown in Fig. 6.14 and four slips are the minimum we can use in this example.

- The first slip selected always gives the right-hand digit(s). In this case 1.0025 mm.
- The second slip and the third slip have been chosen to give the remaining decimal places ($1.470 + 7.500 = 8.970$ mm).
- The fourth slip provides the balance of the whole number ($39.000 - 1.0025 - 1.470 - 7.500 = 30$ mm). Thus the fourth slip is 30 mm. All these sizes are available in the set listed in Table 6.1.

- If protector slips had been used ($2 \times 2.5 \text{ mm} = 5.0 \text{ mm}$) then the 7.500 slip would have been replaced by a 2.50 mm slip.

Slip gauges come in various grades – workshop, inspection and standards room – and their accuracy and cost increases accordingly. They may be used directly for checking the width of slots. They may also be used in conjunction with a DTI for measuring heights and they may also be used for setting comparators as was shown in Fig. 6.11.

6.3 Measuring angles

Angles are measured in degrees and fractions of a degree. One degree of arc is $1/360$ of a complete circle. One degree of arc can be subdivided into minutes and seconds (not to be confused with minutes and seconds of time):

60 seconds (") of arc = 1 minute (') of arc

60 minutes (') of arc = 1 degree (°) of arc

With the introduction of calculators and computers, decimal fractions of a degree are also used. However, 1 minute of arc equals 0.0166666° recurring so there is no correlation between the two systems of subdividing a degree.

6.3.1 Right angles

A right angle is the angle between two surfaces that are at 90° to each other. Such surfaces may also be described as being *mutually perpendicular*. The use of engineers' try-squares and their use for scribing lines at right angles to the edge of a component will be described in Chapter 7. Figure 6.15(a) shows a typical engineer's try-square.

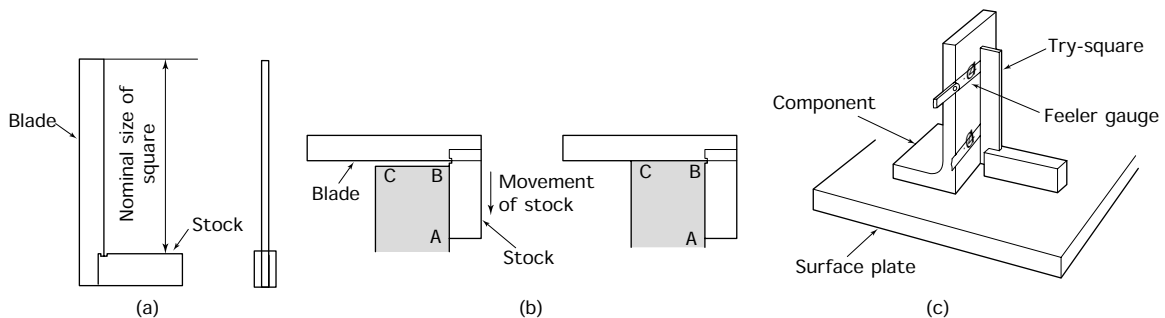


Figure 6.15 *The try-square (a), its use (b) and (c)*

Note that a try-square is not a measuring instrument. It does not measure the angle. It only indicates whether or not the angle being checked is a right angle. In Fig. 6.15(b), the stock is placed against the edge AB of

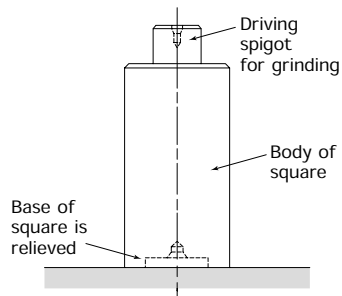


Figure 6.16 *Cylinder square*

the work and slid gently downwards until the blade comes into contact with the edge BC. Any lack of squareness will allow light to be seen between the edge BC and the try-square blade.

It is not always convenient to hold large work and a try-square up to the light. Figure 6.15(c) shows an alternative method using a surface plate as a datum surface. The squareness of the component face is checked with feeler gauges as shown. If the face is square to the base, the gap between it and the try-square blade will be constant.

Try-squares are precision instruments and they should be treated with care if they are to retain their initial accuracy. They should be kept clean and lightly oiled after use. They should not be dropped, nor should they be kept in a draw with other bench tools that may knock up burrs on the edges of the blade and stock. They should be checked for squareness at regular intervals. In addition to try-squares, prismatic squares and cylinder squares may be used for checking large work. Figure 6.16 shows a typical cylinder square.

6.3.2 Angles other than right angles (plain bevel protractor)

Figure 6.17 shows a simple bevel protractor for measuring angles of any magnitude between 0° and 180° . Such a protractor has only limited accuracy ($\pm 0.5^\circ$).

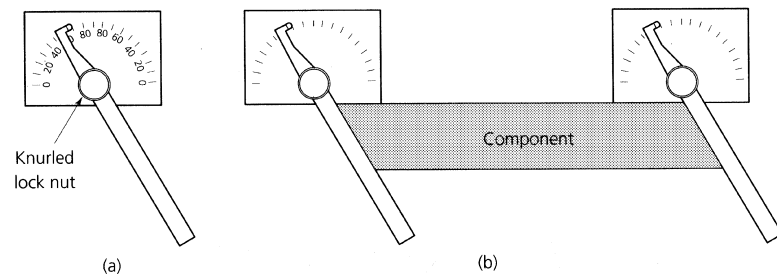


Figure 6.17 *The plain bevel protractor (a), and its use in checking angles (b)*

6.3.3 Angles other than right angles (vernier protractor)

Where greater accuracy is required the vernier protractor should be used. The scales of a vernier protractor are shown in Fig. 6.18. The main scale is divided into degrees of arc, and the vernier scale has 12 divisions each side of zero. These vernier scale divisions are marked 0 to 60 minutes of arc, so that each division is $1/12$ of 60, that is 5 minutes of arc. The reading for a vernier protractor is given by the sum of:

- The largest 'whole' degree on the main scale as indicated by the vernier zero mark.

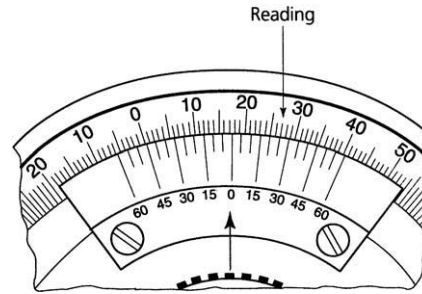


Figure 6.18 *Vernier protractor scales*

- The reading of the vernier scale division in line with a main scale division.

Thus the reading for the scales shown in Fig. 6.18 is:

$$\begin{aligned}
 17 \text{ 'whole' degrees} &= 17^\circ 00' \\
 \text{vernier 25 mark in line with main scale} &= \frac{00 \quad 25'}{60} \\
 \text{Total angle} &= \underline{17^\circ 25'}
 \end{aligned}$$

Vernier protractors are also available which can be read in degrees and decimal fractions of a degree.

6.3.4 Sine bar

Use of a sine bar is a simple but very accurate method of measuring and checking angles. Figure 6.19(a) shows a typical sine bar and Fig. 6.19(b) shows the principle of its use. The sine bar, slip gauges and the datum surface on which they stand form a right-angled triangle with the sine bar as the hypotenuse. Remember that the hypotenuse is the side opposite the right angle in a right-angled triangle.

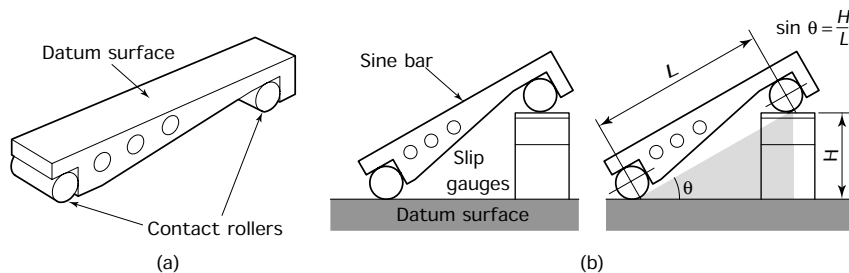


Figure 6.19 *The sine bar (a) and the principle of its use (b)*

$$\text{Since: } \sin \theta = \frac{\text{opposite side}}{\text{hypotenuse}}$$

$$\begin{aligned} \text{Then: } \sin \theta &= \frac{\text{height of slip gauges}}{\text{nominal length of sine bar}} \\ &= \frac{H}{L} \end{aligned}$$

Figure 6.20 shows a component being checked. The slip gauges are chosen to incline the sine bar at the required angle. The component is then placed on the sine bar. The height over the component is checked with a DTI mounted on a surface gauge or a vernier height gauge. If the component has been manufactured to the correct angle, then the DTI will read the same at each end of the component. Any difference in the readings indicates the magnitude of error in the angle of the component. Try working out the height of the slip gauges you would require to give an angle of $\theta = 25^\circ$ if the nominal length (L) of the sine bar is 200 mm. Also state how you would build up the slip gauge stack. The answers are given at the end of this chapter (page 187).

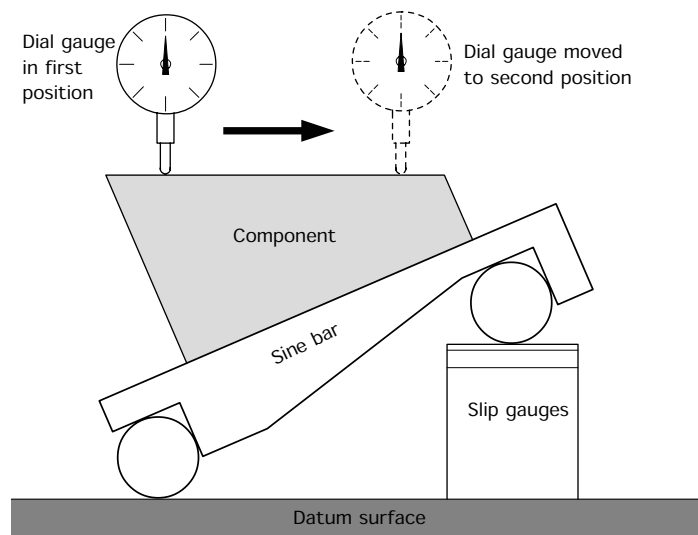


Figure 6.20 Use of the sine bar

6.3.5 Taper plug and ring gauges

Figure 6.21 shows typical taper plug and ring gauges. These cannot measure the angle of taper but they can indicate whether or not the taper is of the correct diameter. The gauges are 'stepped' as shown. If the component is within its 'limits of size' then the end of the taper will lie within the step.

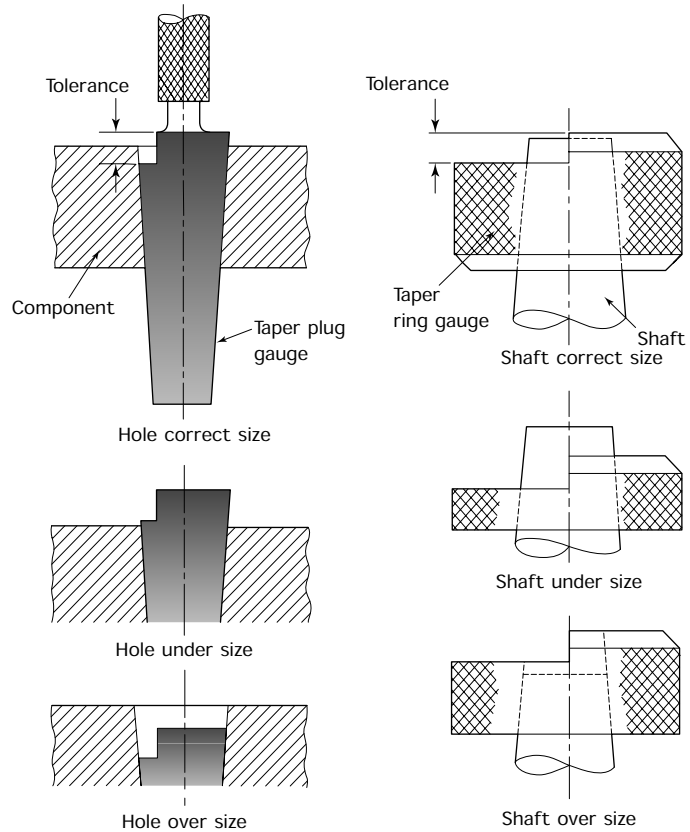


Figure 6.21 *Taper plug and ring gauges*

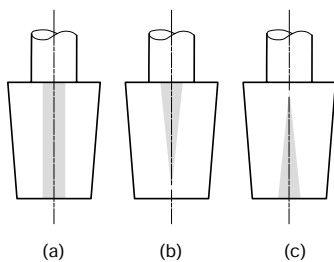


Figure 6.22 *Checking the angle of taper: (a) 'smear' indicates that the hole has the same taper as the plug gauge; (b) 'smear' indicates that the hole has a smaller angle of taper than the gauge; (c) 'smear' indicates that the hole has a larger angle of taper than the gauge*

As already stated, taper plug and ring gauges cannot measure the angle of taper, but they can be used to check the angle as shown in Fig. 6.22. Although a plug gauge is shown, a ring gauge can be used in a similar manner.

Plug gauge

- 'Blue' the gauge with a light smear of engineer's 'blue' and insert the gauge into the hole.
- Remove the gauge taking care not to rock or rotate the plug gauge.
- Wipe the gauge clean of any remaining 'blue'.
- Reinsert the gauge carefully into the hole.
- Upon withdrawing the gauge the smear left upon it will indicate the area of contact. This is interpreted as shown in Fig. 6.22.

Ring gauge

- Lightly 'blue' the shaft and insert it carefully into the ring gauge.
 - Remove the shaft and wipe it clean.
 - Reinsert the shaft into the gauge.
 - Withdraw the shaft and the smear will indicate the area of contact.
 - Interpretation of the smear is similar to that when a plug gauge was used.
-

6.4 Miscellaneous measurements

In addition to the linear and angular measurements described so far, other dimensional properties also have to be considered. Let's now look at some of these.

6.4.1 Flatness

A flat surface lies in a true plane. However, appearances can be deceptive. Figure 6.23 shows a surface that is definitely not flat. Yet, when checked with a rule or a straight edge parallel to its edges along the lines called *generators* it would appear to be flat. It is only when it is checked from corner to corner diagonally that the out-of-flatness shows up.

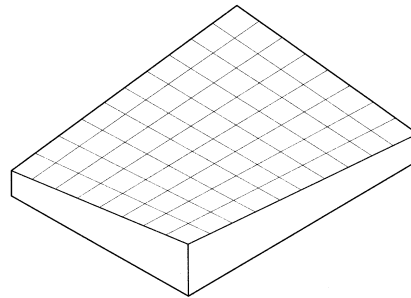


Figure 6.23 *Lack of flatness generated by straight lines and difficult to detect with a straight edge*

6.4.2 Parallelism

Parallelism is the constancy of distance between two lines or surfaces. Parallelism can be measured in a number of ways depending upon the job in hand. Some examples are shown in Fig. 6.24.

6.4.3 Concentricity

Concentricity implies a number of diameters having a common axis. Figure 6.25 shows various ways of testing for concentricity. Figure 6.25(a) shows that a bush with concentric diameters will have

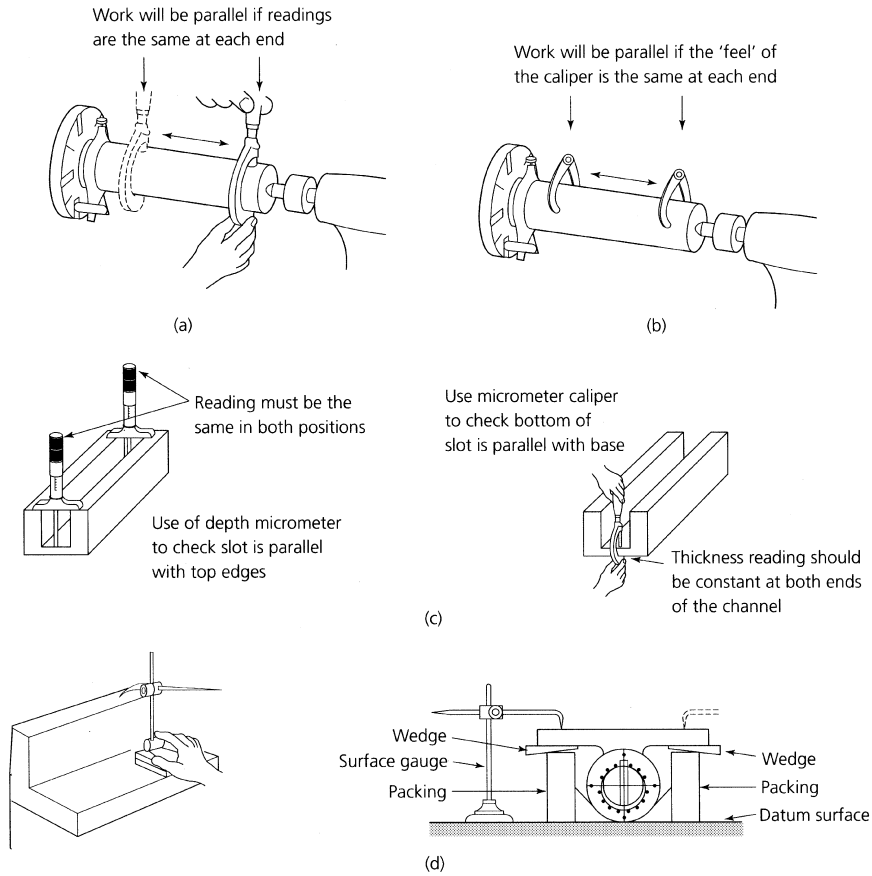


Figure 6.24 Checking for parallelism: (a) with an indicating instrument (micrometer); (b) with a non-indicating instrument (caliper); (c) rectangular components; (d) with a scribing block (surface gauge)

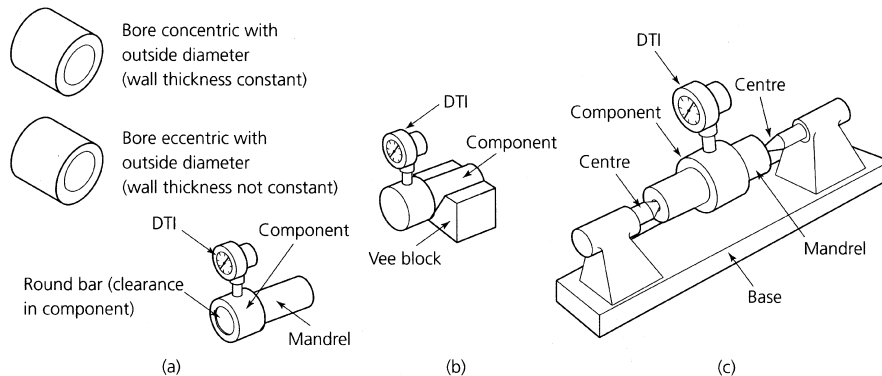


Figure 6.25 Testing for concentricity: (a) constant wall thickness; (b) solid component; (c) bored component

a constant wall thickness. If it does not have a constant wall thickness then the bore and the outer diameter will not be concentric. The bush does not have to be a close fit on the mandrel in this example. Figure 6.25(b) shows a solid component being checked with a DTI and a Vee block. The reading of the DTI must be constant if the diameters are concentric. Figure 6.25(c) shows a component being checked on a mandrel supported between bench centres.

6.4.4 Roundness

To test for roundness, a component has to be checked under a DTI whilst being supported in a Vee block. Any out-of-roundness will cause the component to ride up and down in the Vee block and this will show up as a variable reading on the DTI.

6.4.5 Profiles

The profile of a component is its outline shape. Simple radii can be checked with standard radius gauges as shown in Fig. 6.26(a). More complex profiles can be checked using a half template as shown in Fig. 6.26(b). This template has to be made specifically for the job in hand. For the more accurate checking of profiles an optical projector has to be used. However, optical projectors are beyond the scope of this book.

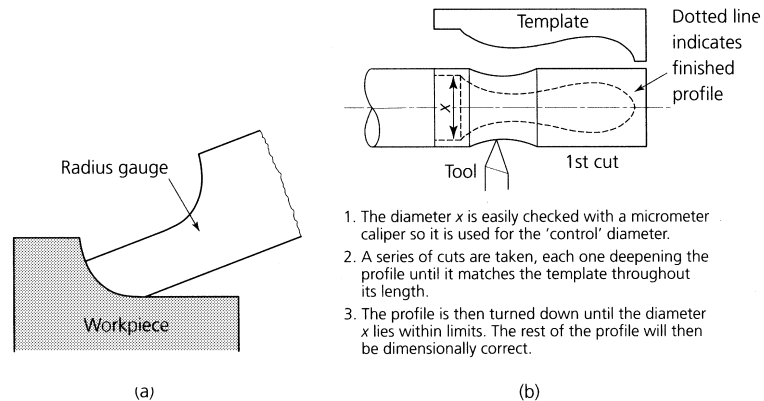


Figure 6.26 Checking a profile: (a) checking a radius with a radius gauge; (b) use of template to turn profile

6.5 Limits and fits

The upper and lower sizes of a dimension are called the *limits* and the difference in size between the limits is called the *tolerance*. The terms associated with limits and fits can be summarized as follows:

- *Nominal size*. This is the dimension by which a feature is identified for convenience. For example, a slot whose actual width is 25.15 millimetres would be known as the 25 millimetre wide slot.

- *Basic size.* This is the exact functional size from which the limits are derived by application of the necessary allowance and tolerances. The basic size and the nominal size are often the same.
- *Actual size.* The measured size corrected to what it would be at 20°C.
- *Limits.* These are the high and low values of size between which the size of a component feature may lie. For example, if the lower limit of a hole is 25.05 millimetres and the upper limit of the same hole is 25.15 millimetres, then a hole which is 25.1 millimetres diameter is *within limits* and is acceptable. Examples are shown in Fig. 6.27(a).

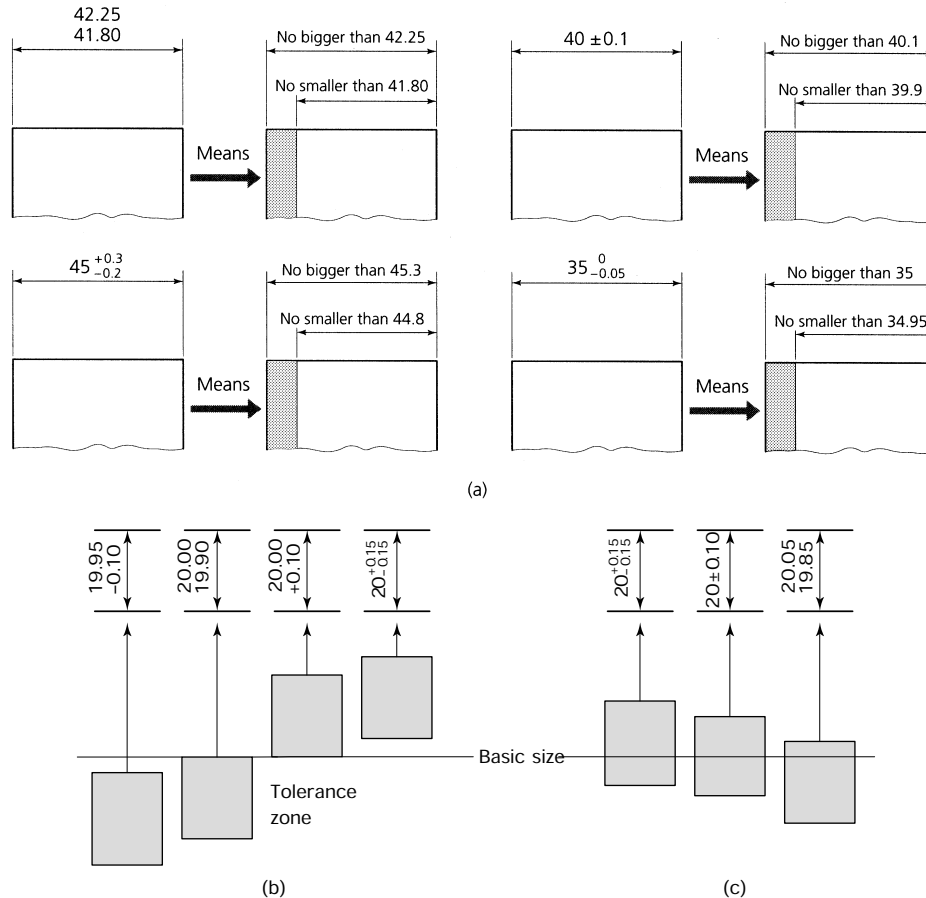


Figure 6.27 Toleranced dimensions: (a) methods of tolerancing; (b) unilateral tolerance; (c) bilateral tolerance

- *Tolerance.* This is the difference between the limits of size. That is, the upper limit minus the lower limit. Tolerances may be bilateral or unilateral as shown in Fig. 6.27(b).

- *Deviation.* This is the difference between the basic size and the limits. The deviation may be symmetrical, in which case the limits are equally spaced above and below the basic size. For example, 50.00 ± 0.15 mm. Alternatively, the deviation may be asymmetrical, in which case the deviation may be greater on one side of the basic size than on the other, e.g. $50.00 + 0.25$ or -0.05 .
- *Mean size.* This size lies halfway between the upper and lower limits of size and must not be confused with either the nominal size or the basic size. It is only the same as the basic size when the deviation is symmetrical.
- *Minimum clearance (allowance).* This is the clearance between a shaft and a hole under maximum metal conditions. That is, the largest shaft in the smallest hole that the limits will allow. It is the tightest fit between shaft and hole that will function correctly. With a *clearance fit* the allowance is positive. With an *interference fit* the allowance is negative. These types of fit are discussed in the next section.

6.6 Classes of fit

Figure 6.28(a) shows the classes of fit that may be obtained between mating components. In the *hole basis system* the hole size is kept constant

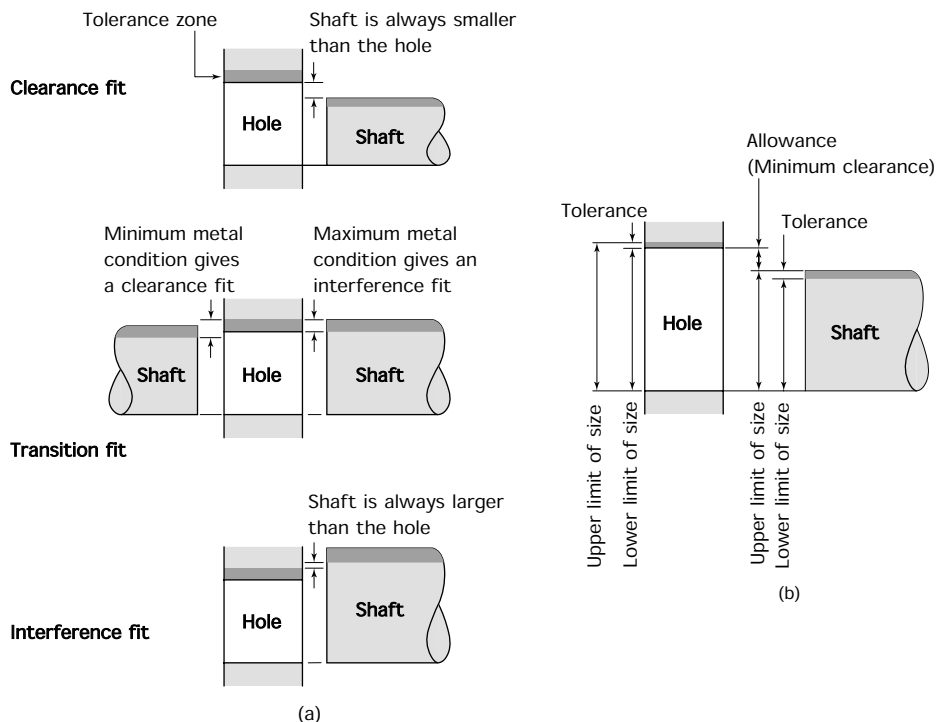


Figure 6.28 Classes of fit (a), terminology of limits and fits (b)

and the shaft size is varied to give the required class of fit. In an *interference fit* the shaft is always slightly larger than the hole. In a *clearance fit* the shaft is always slightly smaller than the hole. A *transition fit* occurs when the tolerances are so arranged that under maximum metal conditions (largest shaft: smallest hole) an interference fit is obtained, and that under minimum metal conditions (largest hole: smallest shaft) a clearance fit is obtained. The hole basis system is the most widely used since most holes are produced using standard tools such as drills and reamers. It is then easier to vary the size of the shaft by turning or grinding to give the required class of fit.

In a *shaft basis system* the shaft size is kept constant and the hole size is varied to give the required class of fit. Again, the classes of fit are: *interference fit*, *transition fit*, and *clearance fit*. Figure 6.28(b) shows the terminology relating to limits and fits.

6.7 Accuracy

The greater the accuracy demanded by a designer, the narrower will be the tolerance band and the more difficult and costly it will be to manufacture the component within the limits specified. Therefore, for ease of manufacture at minimum cost, a designer never specifies an accuracy greater than is necessary to ensure the correct functioning of the component. The more important factors affecting accuracy when measuring components are as follows.

6.7.1 Temperature

All metals and alloys expand when heated and contract when cooled. This is why measuring should take place in a constant temperature environment. You may have noticed that when you are machining materials in a workshop they often become hot. A component which has been heated by the cutting process will shrink whilst cooling to room temperature. This may result in a component that was within limits when measured on the machine but found to be undersize when it is checked in the temperature-controlled inspection room.

6.7.2 Accuracy of equipment

Since it is not possible to manufacture components to an exact size nor is it possible to measure them to an exact size, it follows that neither can measuring equipment be made to an exact size. Therefore measuring equipment also has to be manufactured to toleranced dimensions. In order that this has the minimum effect upon the measurement being made, *the accuracy of a measuring instrument should be about ten times greater than the accuracy of the component being measured.*

Measuring equipment should be checked regularly against even more accurate equipment. Where possible any errors should be corrected by adjustment. If this is not possible, and the error has reached significant proportions, the instrument has to be discarded.

6.7.3 Reading errors

There are two main reading errors:

- Misreading the instrument scales. Vernier scales are particularly difficult to read unless you have very good eyesight, so it is advisable to use a magnifying glass. Good lighting is also essential.
- Parallax (sighting errors) when using rules and similar scales. Care must be taken to ensure that your eye is over the point of measurement.

6.7.4 Type of equipment

It is possible to measure linear dimensions and angles with a variety of instruments. However, the accuracy of measurement is always lower than the reading accuracy and will depend, largely, upon the skill of the user. You must always match the instrument you use to the job in hand. It would be futile to try to measure an accurately machined dimension of 25.00 ± 0.02 millimetres with a rule and calipers. On the other hand, it would be a waste of time to use a vernier caliper when measuring a piece of bar in the stores to see if you could cut a 75 millimetre long blank from it. A rule would be quite adequate for this latter application.

6.7.5 Effect of force

The use of excessive force when closing the measuring instrument on the workpiece being measured can cause distortion of both the workpiece and of the measuring instrument resulting in an incorrect reading. In the worst case the distortion is permanent and either the workpiece or the measuring instrument or both will become worthless and have to be destroyed.

Some instruments are fitted with devices that ensure a correct and safe measuring pressure automatically. For example, three 'clicks' of the ratchet of a micrometer caliper applies the correct measuring force. The bench micrometer shown in Fig. 6.29 has a measuring force indicator (fiducial indicator) in place of the fixed anvil. When the pointers are in line, the correct measuring pressure is being applied.

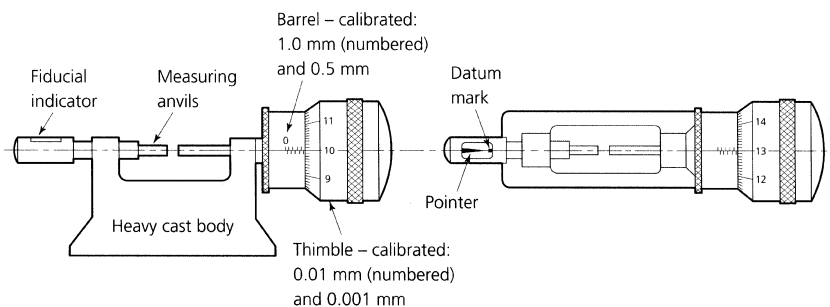


Figure 6.29 *The bench micrometer: the fiducial indicator removes errors of 'feel' – the micrometer is 'zeroed' with the pointer of the fiducial indicator in line with its datum mark and all subsequent measurements are made with the pointer in this position; this ensures constant measuring pressure*

The contact area of the jaws or anvils of the measuring instrument can also influence the measuring pressure. This is because pressure is defined as force per unit area and, for any given measuring force, the contact pressure varies inversely as the contact area. Reduce the area and the measuring pressure is increased. Increase the contact area and the pressure is reduced. A spherically ended stylus will, in theory, result in point contact and this will give rise to an infinitely high measuring pressure. In practice the spherical end on the stylus tends to sink into the surface being measured, thus increasing the contact area. At the same time the spherical end of the stylus tends to flatten and this, again, increases the contact area. Any increase in the contact area results in a decrease in measuring pressure and a balance is automatically achieved between the measuring pressure and the resistance to deformation of the material of the component being measured. Such deformation introduces measuring errors and damage to the finished surfaces of the component being measured. Such effects are marginal where components are made from relatively hard metals but they must be taken into account when measuring components made from softer materials such as some plastics.

6.7.6 Correct use of measuring equipment

No matter how accurately measuring equipment is made, and no matter how sensitive it is, one of the most important factors affecting the accuracy of measurement is the skill of the user. The more important procedures for the correct use of measuring equipment can be summarized as follows.

- The measurement must be made at right angles to the surface of the component.
- The use of a constant measuring pressure is essential. This is provided automatically with micrometer calipers by means of their ratchet. With other instruments such as plain calipers and vernier calipers the measuring pressure depends upon the skill and 'feel' of the user. Such skill comes only with practice and experience.
- The component must be supported so that it does not distort under the measuring pressure or under its own weight.
- The workpiece must be thoroughly cleaned before being measured, and coated with oil or a corrosion inhibiting substance immediately after inspection. Ideally, gloves should be worn so that the acid in your perspiration does not corrode the cleaned surfaces of the instruments and the workpiece.
- Measuring instruments must be handled with care so that they are not damaged or strained. They must be cleaned and kept in their cases when not in use. Their bright surfaces should be lightly smeared with petroleum jelly (vaseline). Measuring instruments must be regularly checked to ensure that they have not lost their initial accuracy. If an

error is detected the instrument must be taken out of service immediately so that the error can be corrected. If correction is not possible the instrument must be immediately discarded.

6.8 Terminology of measurement

Indicated size

This is the size indicated by the scales of a measuring instrument when it is being used to measure a workpiece. The indicated size makes no allowance for any incorrect use of the instrument, such as the application of excessive contact pressure.

Reading

This is the size as read off the instrument scales by the operator. Errors can occur if the scales are misread, for example sighting (parallax) errors can occur when measuring with a rule. Vernier scales are particularly easy to misread in poor light. A magnifying lens is helpful even in good light and even if you have good eyesight. Electronic measuring instruments with digital readouts overcome many of these reading difficulties.

Reading value

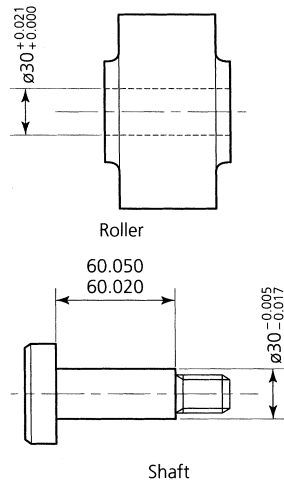
This is also called the 'reading accuracy'. This is the smallest increment of size that can be read directly from the scales of the instrument. It will depend upon the layout of the scales. A micrometer caliper normally has a reading value of 0.01 millimetre. A bench micrometer fitted with a fiducial indicator normally has a reading value of 0.001 millimetre. A vernier caliper with a 50 division vernier scale normally has a reading value of either 0.01 millimetre or 0.02 millimetre depending upon how the scales are arranged.

Measuring range

This is the range of sizes that can be measured by any given instrument. It is the arithmetical difference between the largest size which can be measured and the smallest size which can be measured. For example, a 50 mm to 75 mm micrometer has a measuring range of $75 \text{ mm} - 50 \text{ mm} = 25 \text{ mm}$.

Measuring accuracy

This is the actual accuracy expected from a measuring instrument after taking into account all the normal errors of usage. It can never be better than the indicated size.

Exercises 6.1 *Limits of size***Figure 6.30** *Exercise 6.1(a)*

- Figure 6.30 shows a roller and its shaft. Complete the associated table from the dimensions given.
- The limits of size for the width of a component lie between 11.5 mm and 12.5 mm. With the aid of sketches show THREE ways in which these limits of size may be applied to the dimension.
- With the aid of sketches, show what is meant by:
 - a clearance fit;
 - a transition fit;
 - an interference fit.
- Which of the classes of fit listed in exercise (c) would be required for:
 - a pulley that is free to run on its shaft;
 - a drill bush that has to be pressed into the bushplate of a drilling jig.

6.2 *Measuring equipment*

- List the most important features of an engineer's rule. State briefly how it should be cared for to maintain its accuracy.
- Explain briefly what are the main causes of reading error when using a steel rule and how these errors can be minimized.
- Sketch the following measuring tools showing how they are used:
 - firm-joint calipers;
 - odd-leg (jenny) calipers.
- With the aid of sketches show how an engineer's try-square is used to check the squareness of a rectangular metal blank.

6.3 *Measuring instruments*

- Sketch a micrometer caliper and:
 - name its more important features;
 - show how the scales are arranged for metric readings;
 - show how the scales are arranged for 'inch' readings.
- With the aid of sketches, explain how the scales of a depth micrometer differ from a micrometer caliper.
- Write down the micrometer readings shown in Fig. 6.31(a).
- Sketch a vernier caliper that can be used for internal and external measurements, and also depth measurements. Name its more important features.
- Write down the vernier readings shown in Fig. 6.31(b).
- With the aid of sketches show how a plain bevel protractor is used to measure angles.

6.4 *Gauge blocks*

- Using the slip gauges (gauge blocks) listed in Table 6.1 of the text, select a suitable set of gauge blocks to make up the dimension of 34.147 mm:
 - without using protector slips;
 - using protector slips.

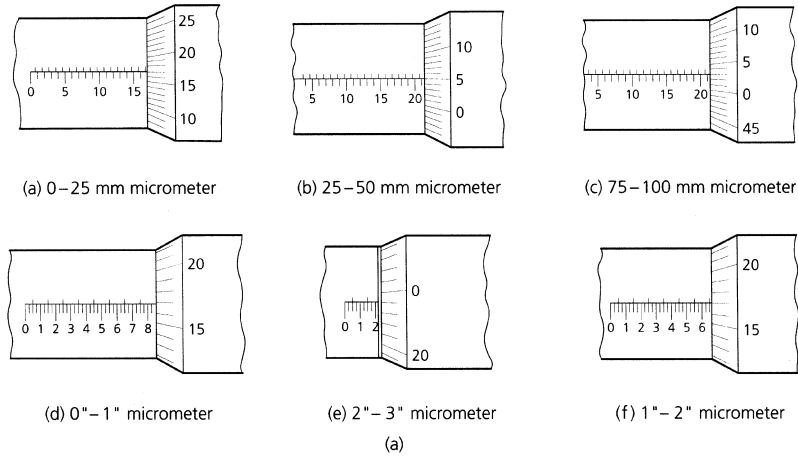


Figure 6.31(a) Exercise 6.3(c)

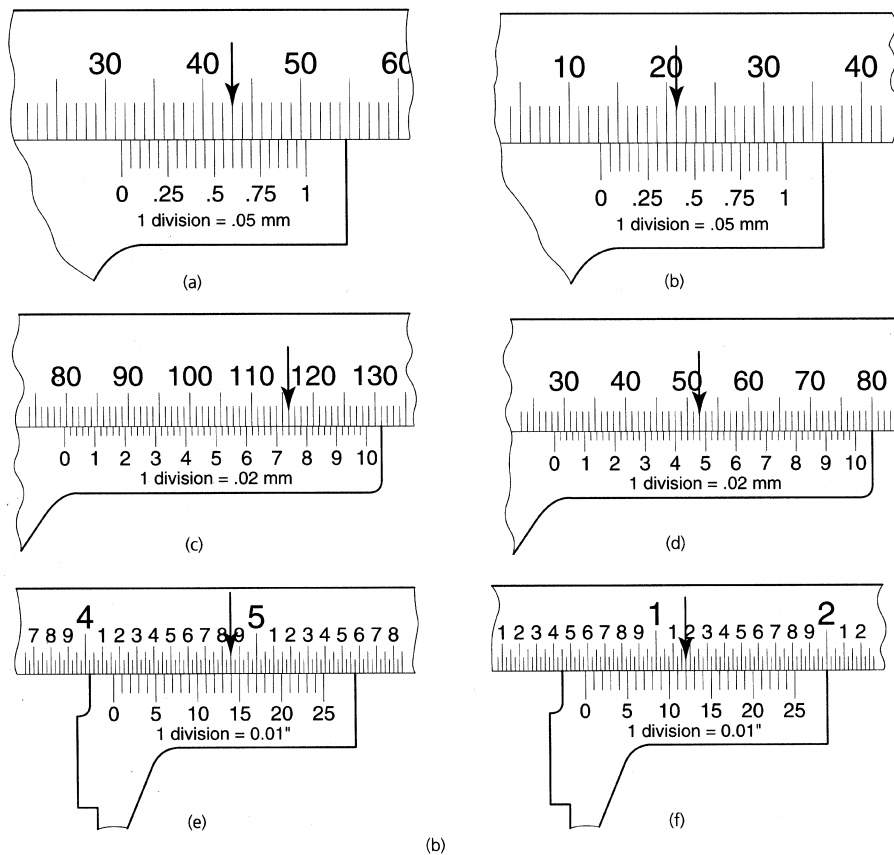


Figure 6.31(b) Exercise 6.3(e)

- (b) With the aid of a sketch explain how slip gauges should be assembled together, and also taken apart, to avoid damage to the gauging surfaces.
- (c) With the aid of sketches explain how slip gauges are used in conjunction with a sine bar to check a tapered component.
- (d) Using slip gauges, a lever type (Verdict) dial test indicator (DTI) mounted on a scribing block, and a surface plate as a datum, describe with the aid of sketches how the component shown in Fig. 6.32 can be checked for thickness and parallelism.

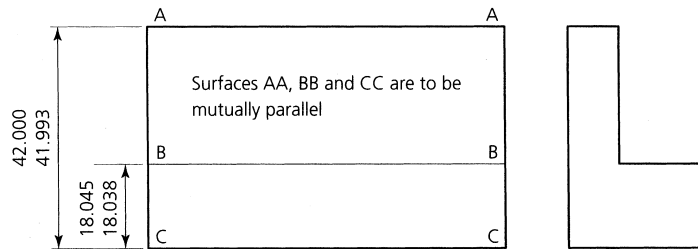


Figure 6.32 Exercise 6.4(d)

6.5 Miscellaneous measuring devices

With the aid of sketches show/explain how the following measuring devices are used.

- (a) A taper plug gauge (stepped) to check the size and angle of taper of a tapered bore.
- (b) Feeler gauges.
- (c) Radius gauges.

Answers Figure 6.6

- (a) 0.178 inch
- (b) 0.044 inch
- (c) 0.215 inch
- (d) 0.175 inch
- (e) 0.487 inch
- (f) 2.00 mm
- (g) 5.23 mm
- (h) 17.78 mm
- (i) 0.31 mm
- (j) 6.05 mm

Figure 6.9

- (a) 3.50 mm
- (b) 13.80 mm
- (c) 21.78 mm
- (d) 6.00 mm

Figure 6.10

- (a) 0.225 inch
- (b) 10.110 inch
- (c) 0.217 inch
- (d) 8.583 inch

Figure 6.20

$$H = 84.52 \text{ mm}$$

Use the following slip gauges

- 1.02 mm
- 0.50 mm
- 8.00 mm
- 75.00 mm
- 84.52 mm

7 Marking out

When you have read this chapter you should be able to understand how to:

- Identify and select marking-out tools for making lines.
- Identify and select marking-out equipment for providing guidance.
- Identify and select marking-out equipment for providing support.
- Identify and select different types of datum.
- Identify and use different co-ordinate systems.
- Mark out workpieces having square, rectangular, circular and irregular-shaped sections.

7.1 Marking-out equipment (tools for making lines)

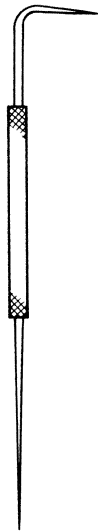


Figure 7.1 Scribe

Marking out is, essentially, drawing on metal so as to provide guide lines for a fitter or a machinist to work to. A pencil line would not be suitable. The hard metal surface would soon make a pencil blunt and the line would become thick and inaccurate; also a pencil line is too easily wiped off a metal surface. Usually the line is scribed using a sharp pointed metal tool, such as a scribe, that cuts into the surface of the metal and leaves a fine, permanent line.

7.1.1 Scribe

This is the basic marking-out tool. It consists of a handle with a sharp point. The pointed end is made from hardened steel so that it will stay sharp in use. Engineers' scribes usually have one straight end and one hooked end, as shown in Fig. 7.1. It is essential that the scribing point is kept sharp. Scribing points should not be sharpened on a grinding machine. The heat generated by this process tends to soften the point of the scribe so that it soon becomes blunt. The scribing point should be kept needle sharp by the use of an oil stone (see Fig. 7.27).

7.1.2 Centre and dot punches

Typical centre and dot punches are shown in Fig. 7.2. They are used for making indentations in the surface of the metal. There are two types of punch. Figure 7.2(a) shows a dot punch. This has a relatively fine point of about 60° or less and is used for locating the legs of such instruments as dividers and trammels. Figure 7.2(b) shows a centre punch. This is heavier than a dot punch and has a less acute point (usually 90° or greater). It is used to make a heavy indentation suitable for locating the point of

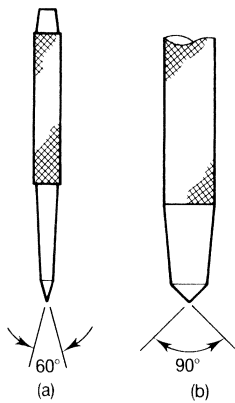


Figure 7.2 *Punches: (a) dot punch; (b) centre punch*

a twist drill. Another use for a dot punch is for ‘preserving’ a scribed 8 (page 212) line as shown in Fig. 7.28 (page 212). This use will be considered in greater detail towards the end of this chapter.

The correct way to use a dot punch is shown in Fig. 7.3. Usually the position for making a dot mark is at the junction of a pair of scribed lines at right angles to each other.

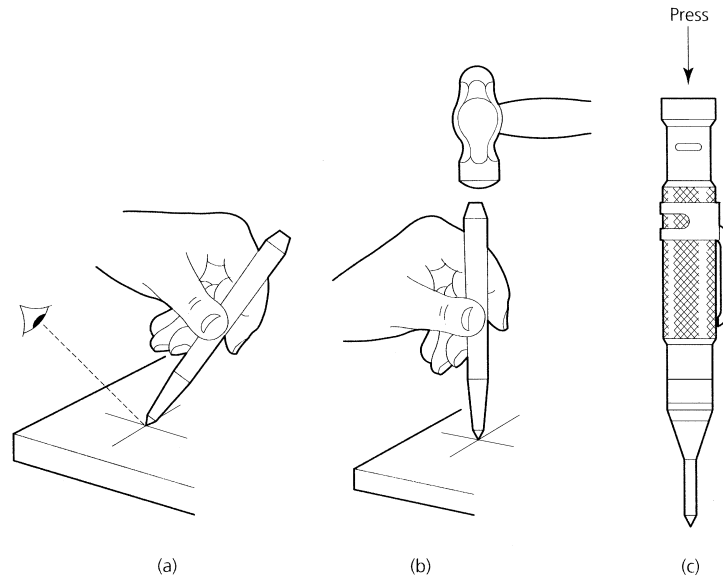


Figure 7.3 *Correct way to use dot and centre punches*

- You hold the punch so that it is inclined away from you. This enables you to see when the point of the punch is at the junction of the scribed lines as shown in Fig. 7.3(a).
- You then carefully bring the punch up to the vertical taking care not to move the position of the point.
- You then strike the punch lightly and squarely with a hammer as shown in Fig. 7.3(b).
- Check the position of the dot with the aid of a magnifying glass. Draw the dot over if it is slightly out of position.

For rough work you can use a centre punch in the same way but you need to hit it harder with a heavier hammer if you are to make a big enough indentation to guide the point of a drill. Because of the difficulty in seeing the point of a centre punch it is preferable to make a dot punch mark and, when you are satisfied that it is correctly positioned, you can enlarge the dot mark with a centre punch. The centre punch is correctly positioned when you feel its point ‘click’ into the mark left by the dot punch.

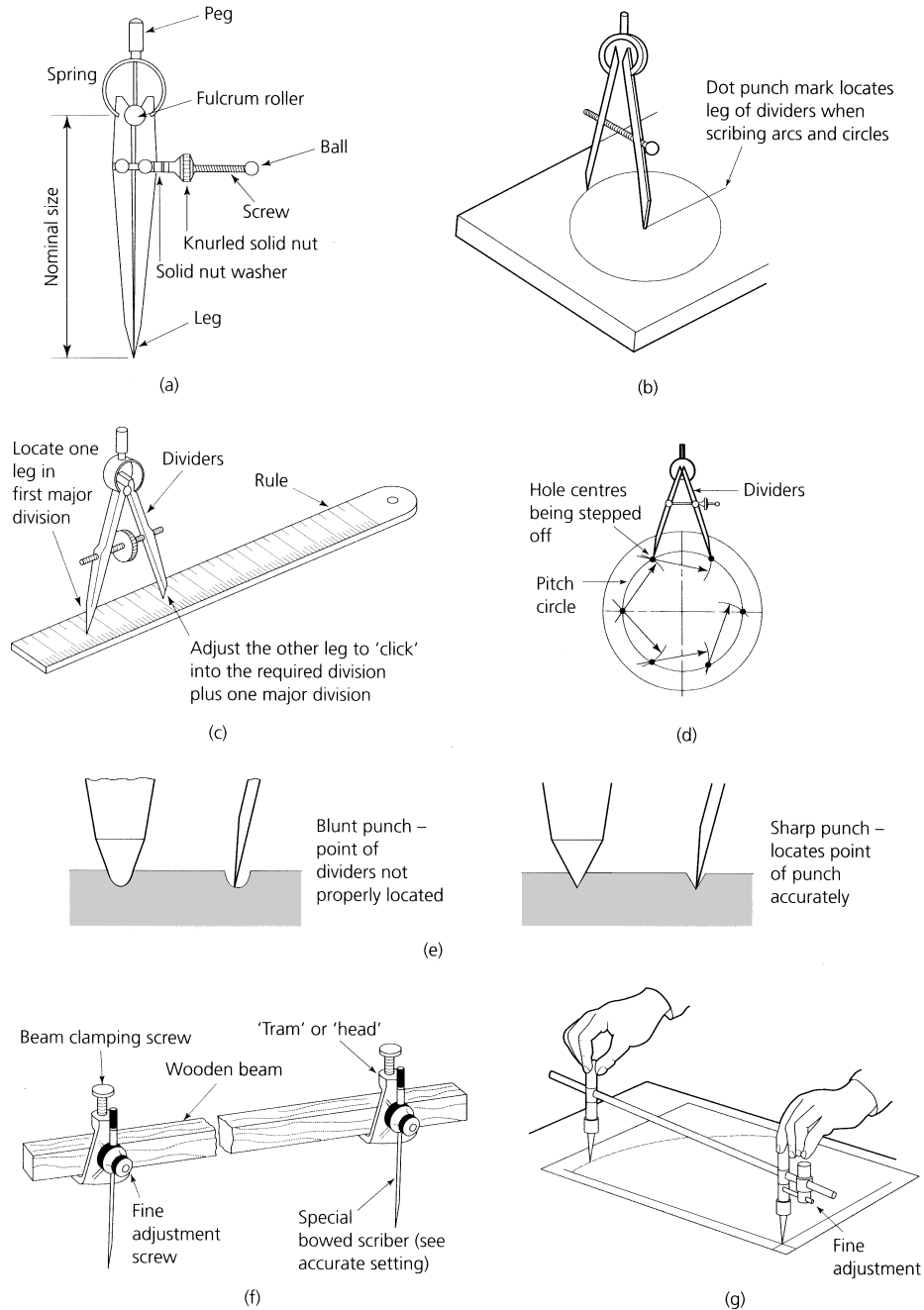


Figure 7.4 Dividers and trammels: (a) parts of a divider; (b) scribing a circle; (c) setting a required radius; (d) stepping off hole centres; (e) location of divider point; (f) trammel or beam compass; (g) adjustment of trammel

Figure 7.3(c) shows an automatic dot punch. This has the advantage that it can be used single handed and it is less likely to skid across the surface of the work. The punch is operated by downward pressure that releases a spring loaded hammer in its body. No separate hammer is required.

7.1.3 Dividers and trammels

These instruments are used for marking out circles and arcs of circles. A typical pair of dividers and the names of its component parts are shown in Fig. 7.4(a). Dividers are used to scribe circular lines as shown in Fig. 7.4(b). They are set to the required radius as shown in Fig. 7.4(c). They are also used for stepping off equal distances (such as hole centres along a line or round a pitch circle) as shown in Fig. 7.4(d). The leg about which the dividers pivot is usually located in a fine centre dot mark. To locate the point of this leg accurately it is essential to use a sharp dot punch as shown in Fig. 7.4(e).

Trammels are used for scribing large diameter circles and arcs that are beyond the range of ordinary dividers. They are also called beam compasses when the scribing points are located on a wooden beam as shown in Fig. 7.4(f). Trammels have a metal beam usually in the form of a solid rod or a tube. This often carries a scale and one of the scribing points is fitted with a vernier scale and a fine adjustment screw for accurate setting as shown in Fig. 7.4(g).

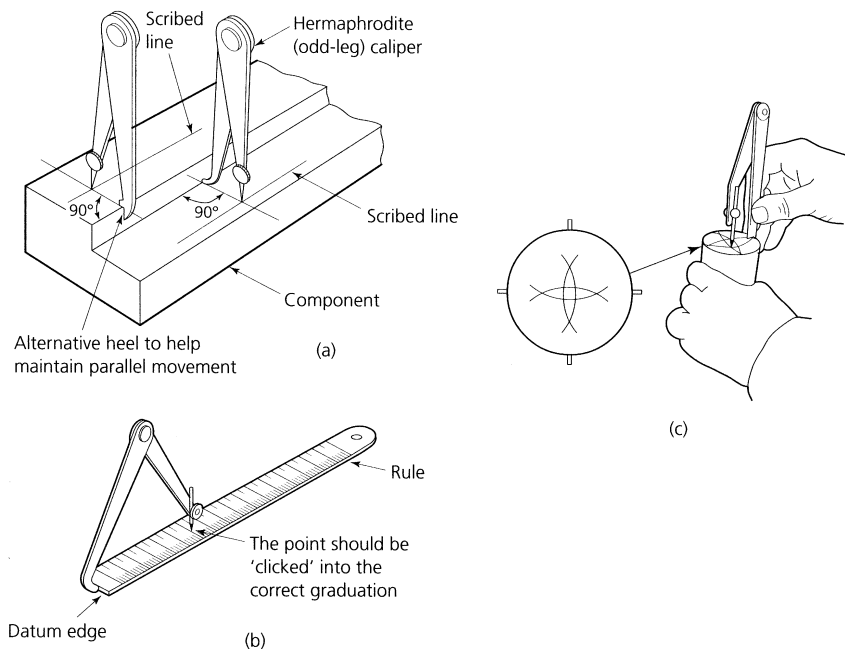


Figure 7.5 Hermaphrodite (odd-leg) calipers: (a) scribing lines parallel to an edge; (b) setting odd-leg calipers; (c) finding the centre of a bar

7.1.4 Hermaphrodite calipers

These are usually called odd-leg calipers or jenny calipers. They consist of one caliper leg and one divider leg and are used for scribing lines parallel to an edge as shown in Fig. 7.5(a). They are set to the required size as shown in Fig. 7.5(b).

7.1.5 Scribing block

A scribing block or surface gauge is used for marking out lines parallel to a datum surface or a datum edge. The parts of a typical scribing block are shown in Fig. 7.6(a) and some typical applications are shown in Fig. 7.6(b). Normally the scribing point is set to mark a line at a given height above the base of the instrument. This line will be marked parallel to the surface along which the base of the instrument is moved. When a line parallel to a datum edge is required, the edge pins are lowered. These pins are then kept in contact with the datum edge as the scribing block is moved along the work.

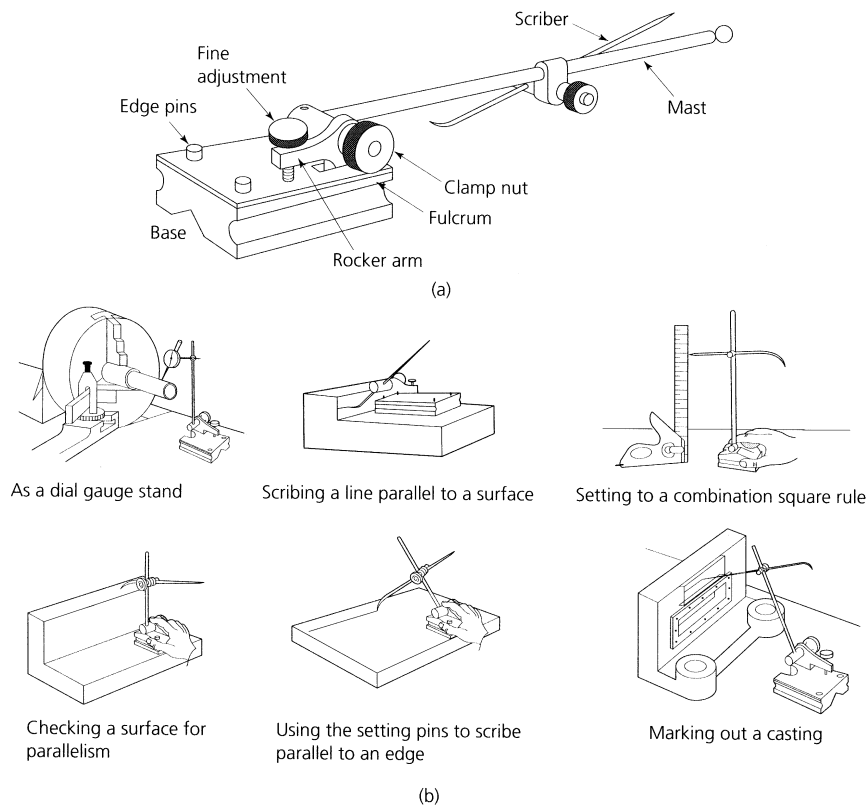


Figure 7.6 *The surface gauge (a) and typical applications (b)*

7.1.6 Vernier height gauge

The vernier height gauge was introduced in Chapter 6 as a measuring instrument. It is also used for scribing lines parallel to a datum surface in a similar manner to a scribing block. However, unlike a scribing block that has to be set to a separate steel rule, a vernier height gauge has a built-in main scale and vernier scale so that it can be set to a high degree of accuracy. The setting and reading of vernier scales was described in Chapter 6. The height gauge is fitted with a removable, sharpened nib. This is set to the required height by the scales provided. To scribe a line parallel to the datum surface, as shown in Fig. 7.7, the following procedure is used.

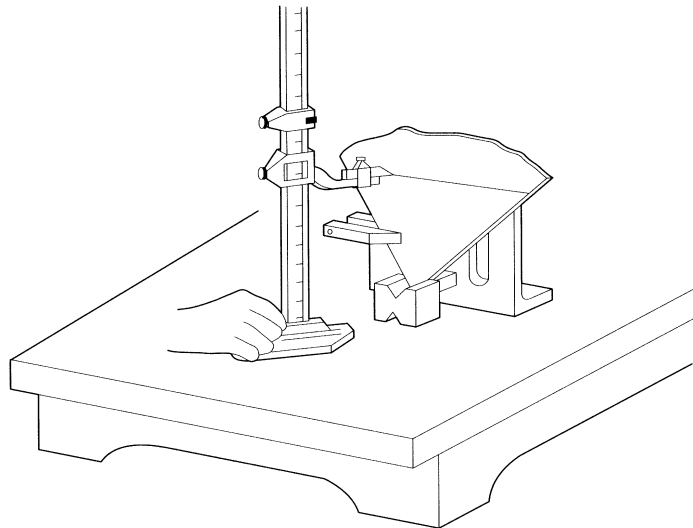


Figure 7.7 Use of a vernier height gauge to scribe a line parallel to a datum surface

- Set the nib of the height gauge to the correct distance from the base of the instrument.
- Keep the base of the height gauge firmly on the datum surface on which it and the work are standing.
- Keep the scribing nib firmly in contact with the work surface.
- Move the height gauge across the datum surface so that the scribing nib slides across the work. Keep the nib at an angle to the work surface so that the nib trails the direction of movement.
- To sharpen the nib without losing the zero setting of the instrument, see Section 7.7, Fig. 7.27(b).

7.2 Marking-out equipment (tools for providing guidance)

You cannot draw a straight line with a scribe without the help of some form of straight edge to guide the scribe. Let's now consider the tools that provide guidance for the scribing point.

7.2.1 Rule and straight edge

Where a straight line is required between two points, a rule can be used or, for longer distances, a straight edge. The correct way to use a scribe is shown in Fig. 7.8(a). The scribe is always inclined away from any guidance edge. Its point should always trail the direction of movement to prevent it 'digging in' to the metal surface so that it produces a poor line and damages the scribing point.

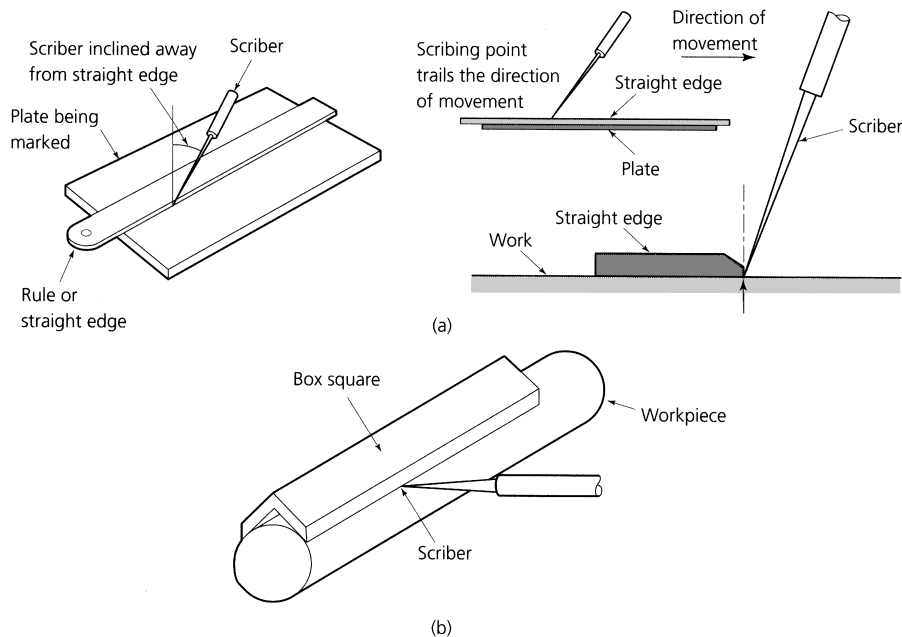


Figure 7.8 *Scribing straight lines: (a) scribing a straight line using a rule as a straight edge; (b) scribing a straight line using a box square*

7.2.2 Box square

This is also known as a key seat rule. It is used for marking and measuring lines scribed parallel to the axis of a cylindrical component such as a shaft. A typical box square and its method of use is shown in Fig. 7.8(b).

7.2.3 Try-square

When you need to scribe a line at 90° to a datum edge a try-square is used as shown in Fig. 7.9. A line scribed at 90° to an edge or another

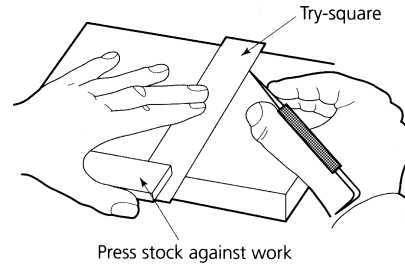


Figure 7.9 *Scribing a line perpendicular to an edge*

line is said to be at *right angles* to that edge or line or it is said to be *perpendicular* to that edge or line. They both mean the same thing.

7.2.4 Combination set

This is shown in Fig. 7.10(a). It consists of a strong, relatively thick and rigid rule together with three 'heads' that are used individually but in conjunction with the rule.

- The square head can be clamped to the rule at any point along its length. It can either be used as a try-square (90°) or as a mitre square (45°) as shown in Fig. 7.10(b).
- The centre head or centre finder can also be clamped to the rule at any point along its length. The edge of the blade that passes through the centre of the centre finder also passes through the centre

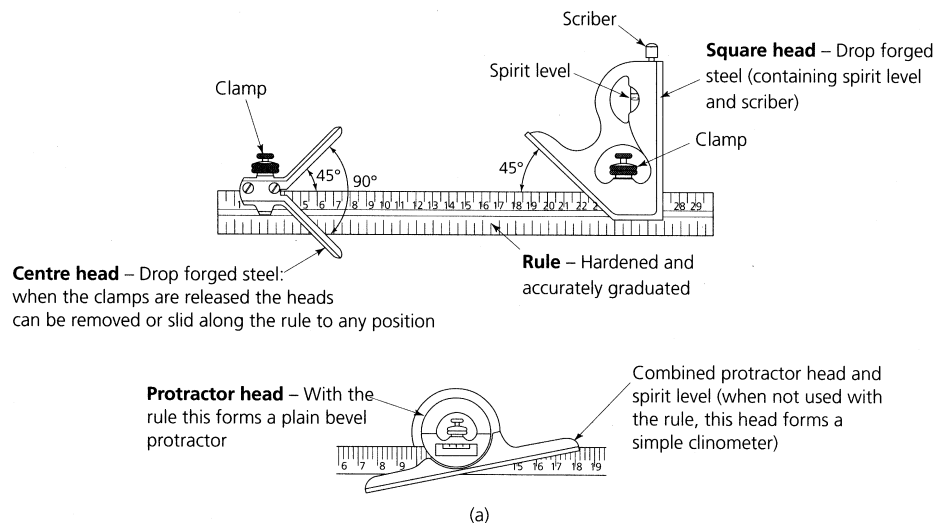


Figure 7.10 *The combination set: (a) construction; (b) uses; (c) finding the centre of a circular component*

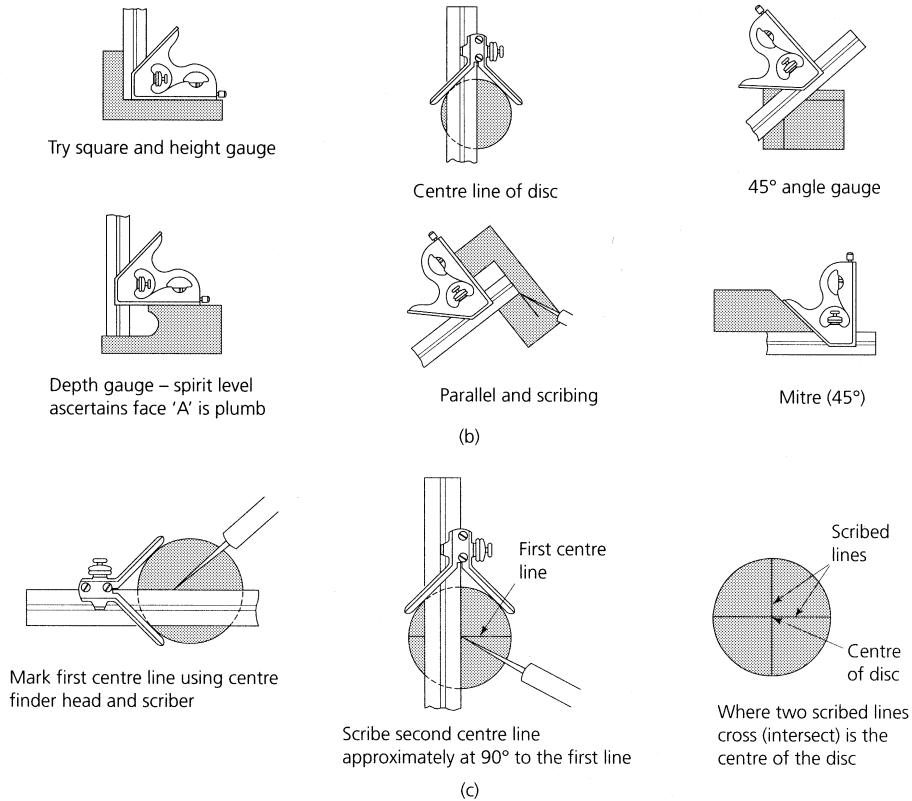


Figure 7.10 (continued)

of the cylindrical workpiece. The centre of the cylindrical workpiece is found by scribing two lines at right angles to each other as shown in Fig. 7.10(c). The lines intersect at the centre of the workpiece.

- A protractor head is also supplied and this is used for marking out lines that are at any angle other than at 90° or 45° to the datum surface or edge.
- The square head and the protractor head are supplied with spirit (bubble) levels for setting purposes. However, they are only of limited accuracy.

7.3 Marking-out equipment (tools for providing support)

When marking out a component, it is essential that the blank is properly supported. As well as keeping the workpiece rigid and in the correct position, the supporting surface may also provide a datum from which to work. A datum is a line, surface or edge from which measurements are taken, but more about that in Section 7.4.

7.3.1 Surface plate and tables

Surface plates are cast from a stable cast iron alloy and are heavily ribbed to make them rigid. An example is shown in Fig. 7.11(a). They are used on the bench to provide a flat surface for marking out small workpieces. They are very heavy and should only be moved with care, preferably by two or more persons in the larger sizes.

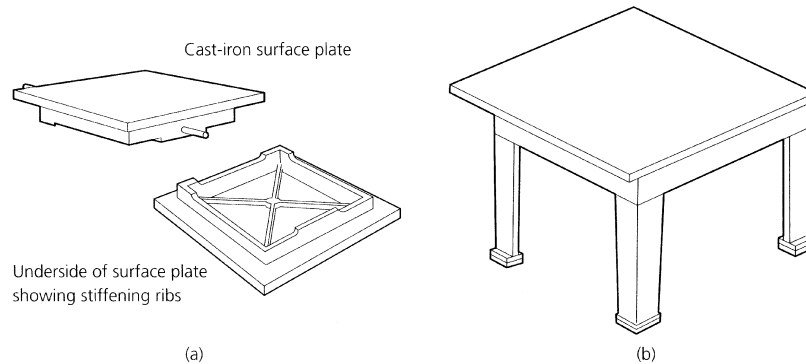


Figure 7.11 Surface plate (a) and marking out table (b)

Surface tables (marking-out tables), such as the one shown in Fig. 7.11(b), are used for providing a support and datum surface when marking out larger workpieces. A marking-out table is of heavy and rigid construction. The working surface may be of cast iron machined or ground flat. Plate glass and granite are also used because of their smoothness and stability. They do not give such a nice 'feel' as cast iron when moving the instruments upon them. This is because cast iron is self-lubricating.

The working surface must be kept clean and in good condition. Nothing must be allowed to scratch or damage the table and heavy objects must be slid gently onto the table from the side. Clean the table before and after use and make sure all sharp corners and rough edges are removed from the workpiece before it is placed on the table. Keep the table covered when it is not in use. Oil the working surface of the table if it is not to be used for some time.

7.3.2 Angle plates

These are also made from good quality cast iron and the working faces are machined at right angles to each other. The ends are also machined so that the angle plate can be stood on end when it is necessary to turn the work clamped to it through 90° . Figure 7.12(a) shows a typical angle plate being used to support work perpendicular to the datum surface of a marking-out table.

Figure 7.12(b) shows an adjustable angle plate. It is used for supporting work at any angle other than at 90° to the datum surface of a marking-out table. There is usually a scale that can be used for initial setting. It is only of limited accuracy and a vernier protractor should be used as shown for more accurate setting.

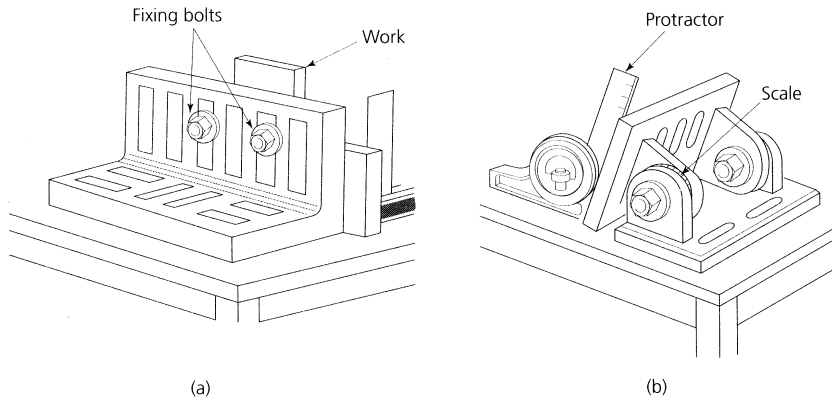


Figure 7.12 *Angle plate (a), adjustable angle plate (b)*

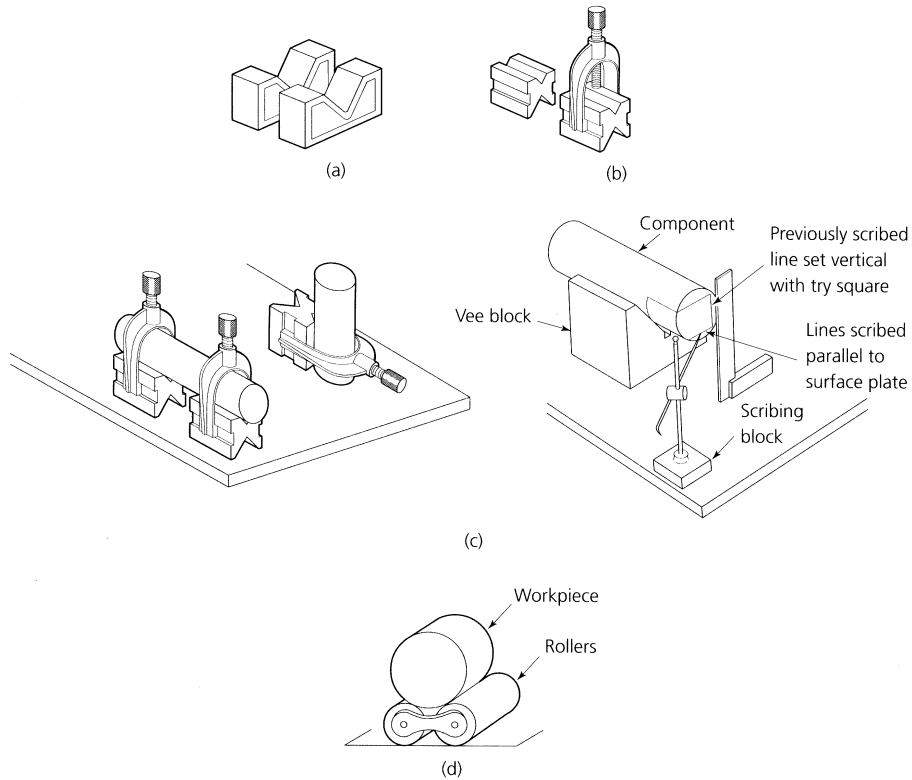


Figure 7.13 *Vee blocks and linked rollers: (a) plain vee blocks; (b) slotted vee blocks with 'horseshoe' clamp; (c) uses of vee blocks; (d) use of linked rollers*

7.3.3 Vee blocks

Vee blocks are used for supporting cylindrical workpieces so that their axes (plural of axis) are parallel to the datum surface. They also prevent the work from rolling about. Figure 7.13(a) shows a pair of plain vee blocks and Fig. 7.13(b) shows a pair of slotted vee blocks with 'horseshoe' clamps. Vee blocks are always manufactured as a matched pair and they should be kept as a matched pair. This ensures the axis of the work is parallel to the datum surface of the marking-out table. Figure 7.13(b) shows some applications of vee blocks. As well as vee blocks, linked rollers are also used for supporting cylindrical work as shown in Fig. 7.13(d).

7.3.4 Parallels

These are parallel strips of hardened and ground steel of square or rectangular section. They are used for supporting and raising work. They are manufactured in various sizes and, like vee blocks, are always manufactured in pairs. This ensures the supported work is always parallel to the datum surface of the marking-out table.

7.3.5 Jacks, wedges and shims

Adjustable screw jacks are used to provide additional support for heavy castings, as shown in Fig. 7.14. Without the jack, the overhanging weight of the casting would make it unstable so that it would tend to fall over.

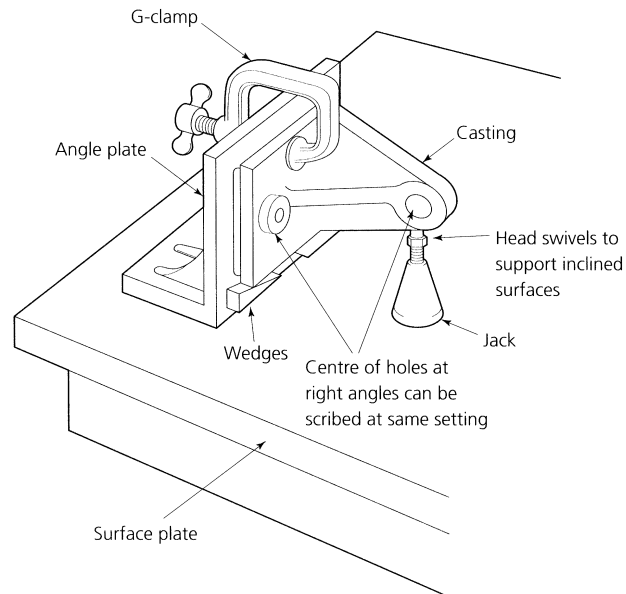


Figure 7.14 Supporting larger work

Wedges are also useful in levelling heavy components, as shown in Fig. 7.14. Where wedges are too thick, shims can be used. Shims are cut from thin hard-rolled brass or steel strip. The strip is supplied in graded thicknesses. They are used for packing the work level. It is always better to use one thick shim than two or more thin shims.

7.4 The purposes, advantages and disadvantages of manual marking out

For most jobbing work, prototype work, toolroom work and small quantity production, components are usually marked out as a guide to manufacture. The purposes, advantages and disadvantages of manual marking out can be summarized as follows.

7.4.1 Purposes and advantages

- To provide guide lines that can be worked to, and which provide the only control for the size and shape of the finished component. This is suitable only for work of relatively low accuracy.
- To indicate the outline of the component to a machinist as an aid for setting up and roughing out. The final dimensional control would come, in this instance, from precision instruments used in conjunction with the micrometer dials of the machine itself.
- To ensure that adequate machining allowances have been left on castings and forgings before expensive machining operations commence. The features checked are surfaces, webs, flanges, cored holes and bosses. In the example shown in Fig. 7.15, it is obvious that the base will not clean up. Neither is the web central nor will the bored hole be central in the boss. There would be no point in machining this casting.

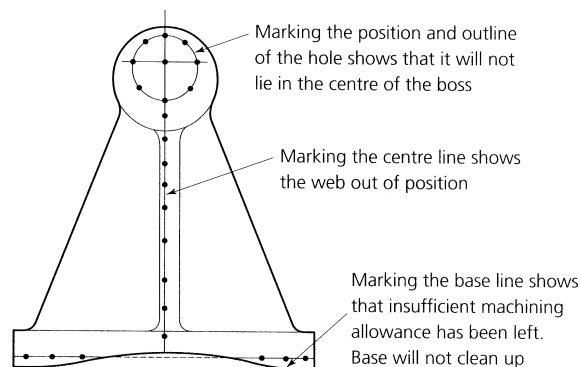


Figure 7.15 *Checking a clamp*

7.4.2 Disadvantages

- Scribed lines cut into the surface of the workpiece and deface the surface of the metal. Where the surface finish is important, allowance

must be left for surface grinding to remove the scribed marks on completion of the component. Any marks cut into the surface of the metal are a potential source of fatigue failure and cracking during heat treatment and bending.

- The above disadvantages cannot be overcome by drawing with a pencil as this would not be sufficiently permanent nor sufficiently accurate. The only exception is in sheet metal work where fold lines are drawn with a soft pencil to avoid cutting through the protective coating of tin (tin-plate) or of zinc (galvanized sheet). Damage to such coatings leads to failure through corrosion.
- Centre punch marks may not control the drill point with sufficient accuracy unless the metal is heavily indented and, even then, total control cannot be guaranteed.
- Centre punching can cause distortion of the work. If the work is thick and the mark is not near the edges, a burr will still be thrown up round the punch mark. When the mark is near the edge of the metal – especially thin metal – the edge of the metal will swell out adjacent to the mark. This can cause inaccuracies if the distorted metal is a datum surface. Thin material, such as sheet metal, may buckle and distort when centre punched. Only the lightest marks should be made in such material.
- The accuracy of a scribed line to rule accuracy is limited to about ± 0.5 mm. When using a vernier height gauge this improves to about ± 0.1 mm. In practice the accuracy depends upon the condition of the scribing point and the skill of the person using the equipment.

7.5 Types of datum

The term datum has already been used several times in this chapter. It has also been described as a point, line or edge from which measurements are taken. Let's now examine the different types of datum in more detail.

- *Point datum.* This is a single point from which dimensions can be taken when measuring and marking out. For example, the centre point of a pitch circle.
- *Line datum.* This is a single line from which or along which dimensions are taken when measuring and marking out. It is frequently the centre line of a symmetrical component.
- *Edge datum.* This is also known as a *service edge*. It is a physical surface from which dimensions can be taken. This is the most widely used datum for marking out. Usually two edges are prepared at right angles to each other. They are also referred to as *mutually perpendicular* datum edges. These two edges ensure that the distances marked out from them are also at right angles to each other.
- *Surface datum.* For example, this can be the working surface of a surface plate or a marking-out table. It provides a common datum to support the work and the measuring and marking-out equipment in the

same plane. For example, if you set your work with its datum edge on the surface datum of the marking-out table, and you set your surface gauge or scribing block to 25 mm, then the line you scribe on your work will be 25 mm from its datum edge. This is because the datum surface of the foot of the surface gauge and the datum surface of your work are both being supported in the same plane by the surface plate or marking-out table, as shown in Fig. 7.16.

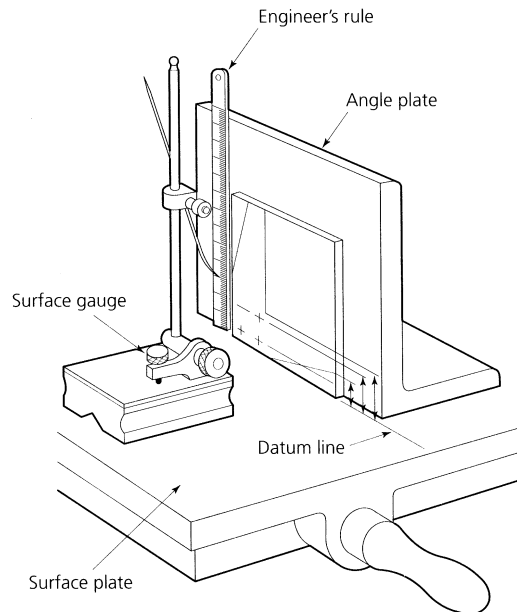


Figure 7.16 Marking out from a datum surface

7.5.1 Co-ordinates

The distance from a datum to some feature such as the centre of a hole is called an *ordinate*. In practice, two such dimensions are required to fix the position of a feature on a flat surface. These two ordinates are called *co-ordinates*. There are two systems of co-ordinates in common use.

7.5.2 Rectangular co-ordinates

The feature is positioned by a pair of ordinates (co-ordinates) lying at right angles to each other and at right angles to the two axes or datum edges from which they are measured. This system requires the preparation of two mutually perpendicular datum edges before marking out can commence. Figure 7.17(a) shows an example of the centre of a hole dimensioned by means of rectangular co-ordinates. Sometimes rectangular co-ordinates are called *Cartesian* co-ordinates.

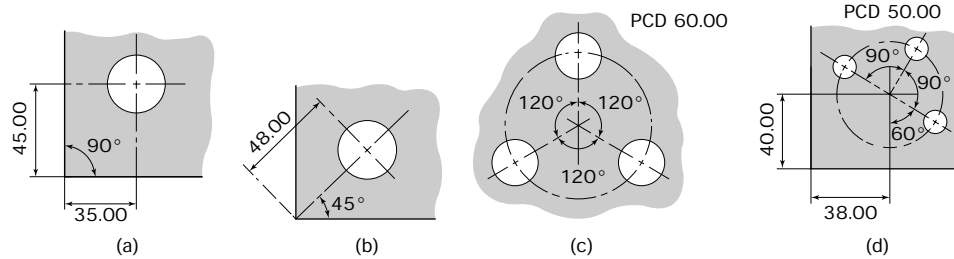


Figure 7.17 Co-ordinates: (a) rectangular co-ordinates; (b) polar co-ordinates; (c) polar co-ordinates applied to holes; (d) combined co-ordinates (Note: PCD = pitch circle diameter: dimensions in millimetres)

7.5.3 Polar co-ordinates

In this instance the co-ordinates consist of a linear (straight line) distance and an angular displacement. Figure 7.17(b) shows how the centre of a hole can be dimensioned using polar co-ordinates. Dimensioning by this technique is often employed when holes are located around a pitch circle or when machining is taking place on a rotary table. Figure 7.17(c) shows how polar co-ordinates are used to position holes around a pitch circle. In this example, the linear dimension is the radius of the pitch circle measured from a point datum at its centre. In practice, polar co-ordinates are rarely used in isolation. They are usually combined with rectangular co-ordinates as shown in Fig. 7.17(d).

7.6 Techniques for marking out

Having familiarized ourselves with the equipment used for marking out, the types of datum and the systems of co-ordinates, it is time to apply this knowledge to some practical examples.

7.6.1 Surface preparation

- Before commencing to mark out a metal surface, the surface must be cleaned and all oil, grease, dirt and loose material removed.
- A dark pencil line shows up clearly on white paper because of the colour contrast. Since scribed lines cut into the metal surface there is very little colour contrast and they do not always show up clearly.
- To make the line more visible, the metal surface is usually coated in a contrasting colour. Large castings are usually whitewashed, but smaller steel and non-ferrous precision components are usually coated with a quick drying layout 'ink'.
- Avoid using the old-fashioned technique of copper plating the surface of a steel component with a solution of copper sulphate containing a trace of sulphuric acid. Although it leaves a very permanent coating, it can be used only on steels and it is corrosive if it gets on marking-out instruments. The coating can be removed only by using emery cloth or by grinding.

- Layout ink is available in a variety of colours and can be readily applied to a smooth surface using an aerosol can. The ink should be applied thinly and evenly. Two thin coats are better than one thick coat. Wait for the ink to dry before marking out. The ink can be removed with a suitable solvent when the component is finished.
- **Safety.** Direct the spray only at the workpiece, never at your work-mates. Obey the maker's instructions at all times. Use only if there is adequate ventilation. Avoid breathing in the solvent and the propellant gas.

7.6.2 Use of a line datum

Figure 7.18 shows a simple link involving straight lines, arcs, and circles. It is symmetrical about its centre line. There are several ways of marking out this component. For the moment a centre line datum will be used.

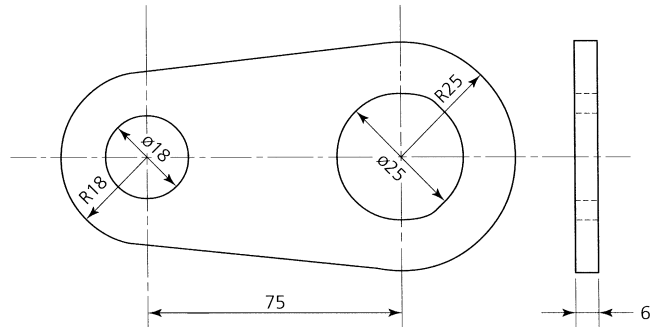


Figure 7.18 *Link: dimensions in millimetres*

Let's assume that we have a flat metal plate of the correct thickness and big enough from which to cut the link. The following operations refer to Fig. 7.19.

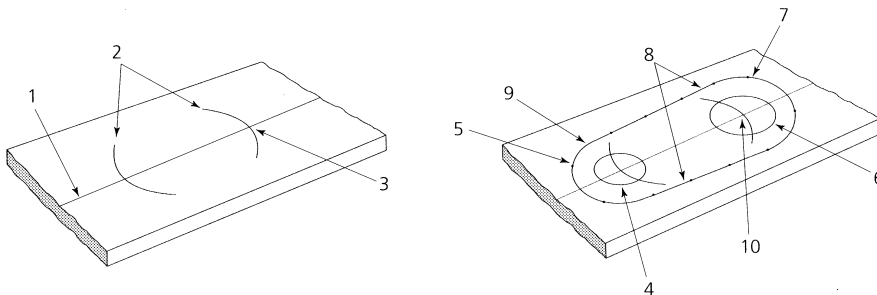


Figure 7.19 *Marking out from a centre line datum*

1. Clean the blank (plate) so as to remove all oil, grease and dirt. Remove all sharp corners for safety. Apply a light coating of layout

ink to the surface of the blank that is to be marked out. Using a steel rule as a straight edge scribe a centre line along the middle of the plate.

2. Set your dividers to the hole centre distance of 75 mm and step off this distance on the centre line. Leave sufficient room to strike the arcs that form the ends of the links.
3. Lightly dot punch the intersections of the centre line and the arcs you have struck with your dividers. These centre dots are used to locate the leg of the dividers in the following operations.
4. Set your dividers to 9 mm and scribe in the 18 mm diameter hole.
5. Set your dividers to 18 mm and, using the same centre dot as in (4), strike the smaller end radius.
6. Set your dividers to 12.5 mm and, using the other centre dot, scribe in the 25 mm diameter hole.
7. Set your dividers to 25 mm and, using the same centre dot as in (6), strike the larger end radius.
8. Scribe tangential lines to join the 18 mm and 25 mm end radii using your steel rule as a straight edge to guide the scriber.
9. Preserve the outline by dot punching as described in Section 7.1.2. The use of witness lines and marks is discussed further in Sections 7.6.7, 7.6.8, 7.6.9 and 7.6.10.
10. Enlarge the hole centre dot punch marks with a centre punch ready for drilling. This completes the marking out.

7.6.3 Use of a single edge datum

The following sequence of operations refers to Fig. 7.20. It assumes that the metal blank from which we are going to make the link has at least one straight edge. This would be the case if the blank was sawn from a piece of 75 mm by 6 mm bright-drawn, low carbon steel.

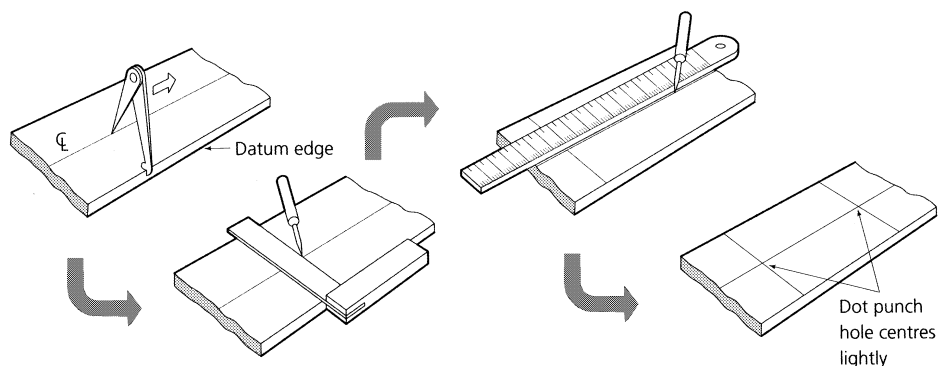


Figure 7.20 *Marking out from a datum edge*

1. Clean the sawn blank so as to remove all oil, grease and dirt. Remove all sharp corners for safety. Apply a light coat of layout ink. Use a steel rule as a straight edge to check the selected datum edge for flatness and straightness. Carefully remove any bruises with a fine file.
2. Scribe the centre line parallel to the datum edge using odd-leg calipers as shown.
3. Scribe the first centre line at right angles to the datum edge using a try-square to guide the scriber point and leaving room for striking the arc that forms the end of the link.
4. Measure and mark off the centre distance to the second hole either by using your rule and scriber as shown or by stepping off the distance with dividers set to 75 mm as in the previous example.
5. Scribe the second hole centre line at right angles to the datum edge using a try-square. Dot punch the centre points.
6. The remaining operations are the same as (4) to (10) inclusive in the previous example.

An alternative method is shown in Fig. 7.21. Clamping the blank to an angle plate provides the same effect as having a pair of mutually perpendicular datum edges. This enables us to scribe the centre lines at right angles to each other without the use of a try-square. By using a vernier height gauge the centre distance can be marked out much more accurately than by using a scribing block as shown below. The plate can be clamped by using small G-clamps as shown or by using toolmaker's clamps.

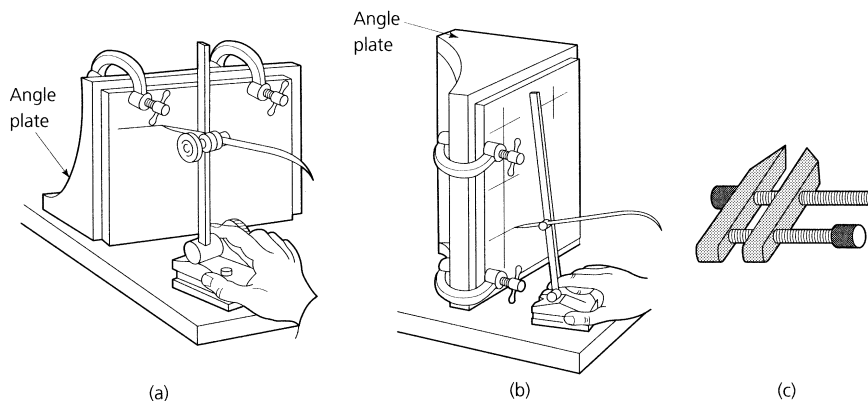


Figure 7.21 Use of angle plate: (a) to provide mutually perpendicular surfaces; (b) toolmaker's clamp

7.6.4 Mutually perpendicular datum edges

This time we will assume that our blank has two datum edges that are at right angles to each other; they are mutually perpendicular. The general set-up for marking out is shown in Fig. 7.22 and the following sequence of operations refers to Fig. 7.23.

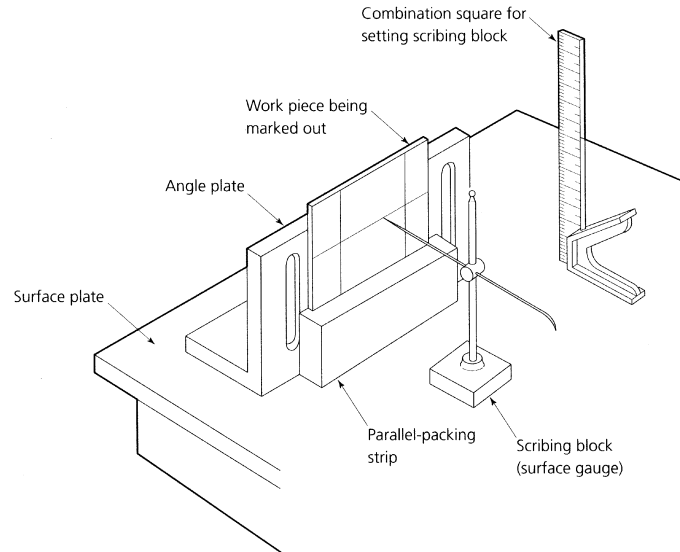


Figure 7.22 *Marking out from a datum surface – the surface plate provides the datum surface; all measurements are made from this surface; all lines scribed by the scribing block will be parallel to this surface*

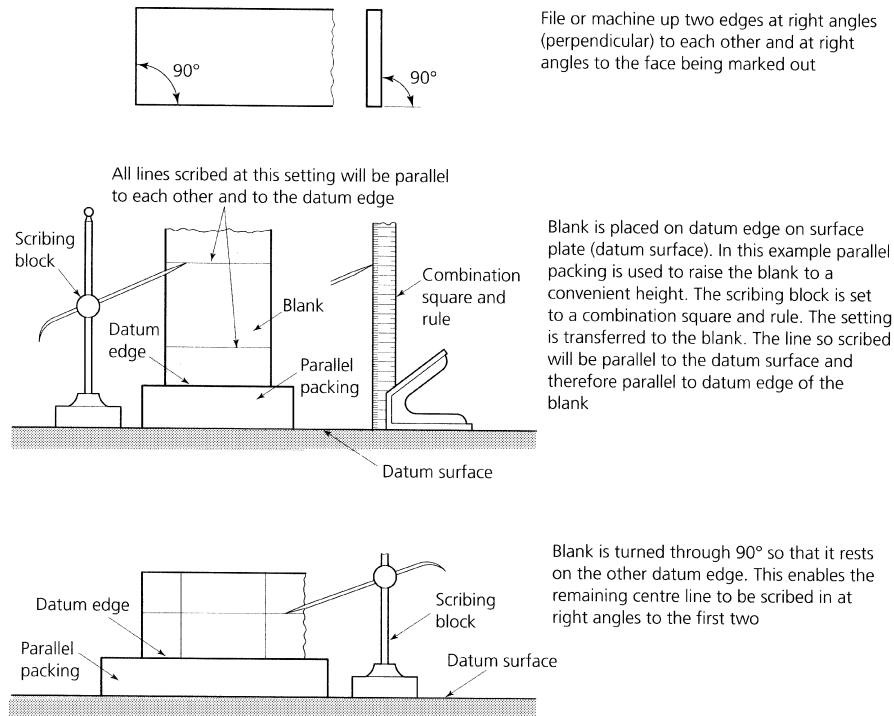


Figure 7.23 *Marking-out procedure when using a datum surface*

1. File or machine two edges at right angles to each other and to the surface being marked out. Remove all sharp edges, oil, grease and dirt from the blank and apply a light coat of layout ink.
2. The blank is placed on its end datum edge on a marking-out table as shown. A precision ground, parallel packing block is used to raise the work to a convenient height. The thickness of the packing must be measured and allowed for when setting the scribing point. The point of the scriber is set to the combination rule. Make sure the datum end of the rule is in contact with the surface of the marking-out table. A line is now scribed on the blank at this setting. The scribing point is raised by 75 mm and a second line is scribed as shown.
3. The blank is then turned through 90° so that it rests on the other datum edge. This enables the remaining centre line to be scribed at right angles to the first two. Where the lines intersect are the hole centres. Dot punch these centres lightly. The marking out of the link is completed as described in operations (4) to (10) inclusive in the first example. If greater accuracy is required a vernier height gauge is used in place of the scribing block.

7.6.5 Use of a point datum and tabulated data

Figure 7.24 shows a component that has been drawn using rectangular co-ordinates and absolute dimensioning for the hole centres. Each hole centre then becomes a *point datum* for the clusters of small holes. To avoid confusion on the drawing, the large number of repeated dimensions for the holes has been tabulated. This is referred to as tabulated data.

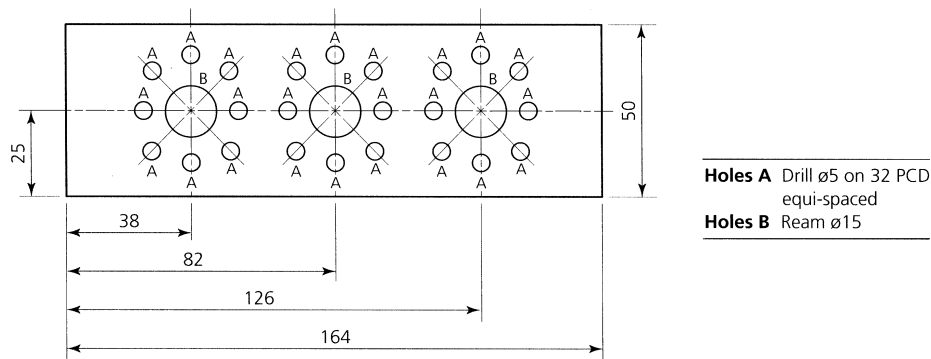


Figure 7.24 *Tabulated data*

Because the major hole centres have been dimensioned using rectangular co-ordinates, they can be marked out as described previously. The dot punch marks at the intersection of the centre lines are used to locate the dividers. These are used to mark out the outline of the 15 mm diameter holes and also the 32 mm diameter pitch circles for the smaller holes. Since there are eight equi-spaced holes in each cluster, they will be at

45° to each other. We can mark out their centre positions using the square and mitre head from the combination set as shown in Fig. 7.25(a). Had there been six holes, their chordal distance would have been the same as the pitch circle radius. Therefore, after marking out the pitch circles, the hole centres could have been stepped off with the dividers at the same setting, as shown in Fig. 7.25(b).

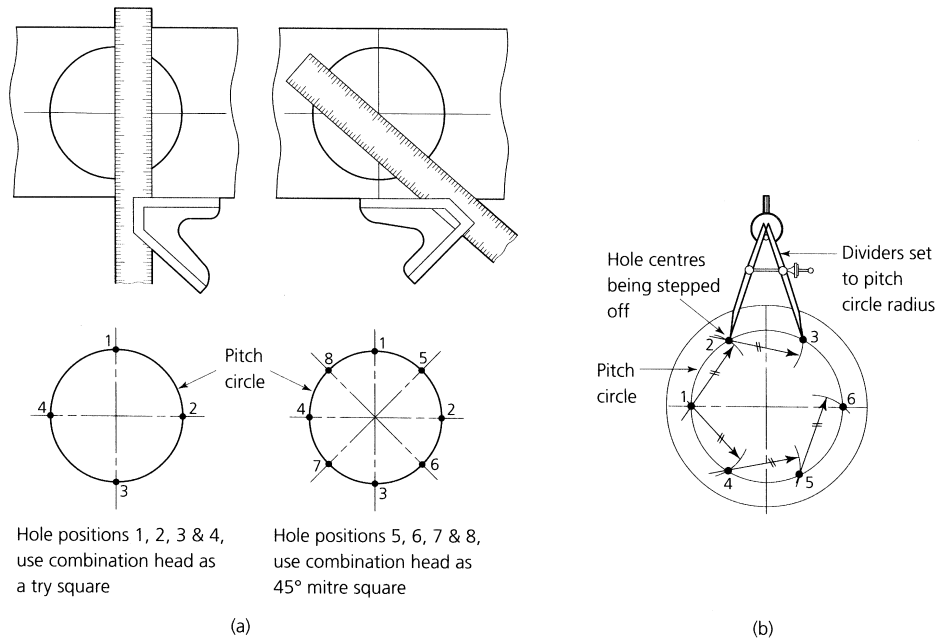


Figure 7.25 Marking-out holes on a pitch circle: (a) use of combination square; (b) use of dividers

Sometimes a drawing has to satisfy a family of similar components that only vary in size but not in shape. Such an example is shown in Fig. 7.26. This drawing has tabulated dimensions for the overall length and the hole centres. The width and thickness of the component remains constant and the holes are located on the centre line that is also constant.

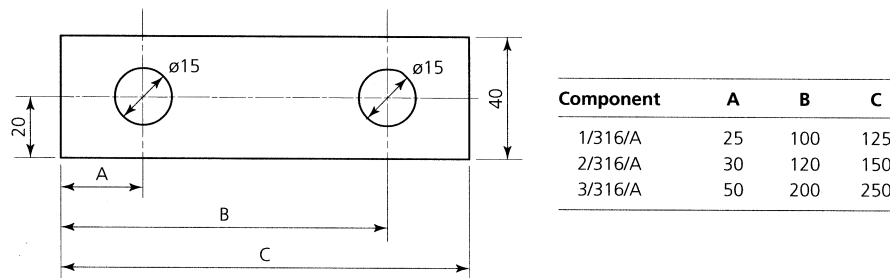


Figure 7.26 Tabulated dimensions

7.6.6 Condition and care of equipment

Marking-out equipment should be kept in good condition if inaccuracies are to be avoided.

- As has been mentioned previously, the points of scribers and dividers should be kept needle sharp by regular dressing with a fine oil slip stone. This is shown in Fig. 7.27(a). Do not sharpen by grinding, the heat generated will soften the scribing point.

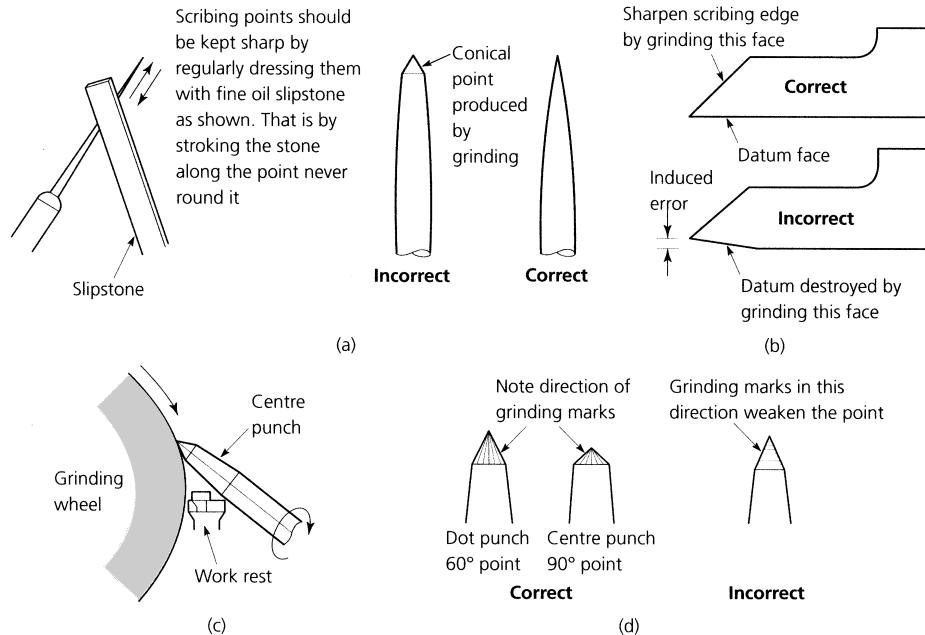


Figure 7.27 Care of marking-out equipment: (a) sharpening scriber points; (b) sharpening height gauge scribing blades; (c) sharpening centre and dot punches; (d) correct dot and centre punch point configurations

- The nib of the vernier height gauge should be sharpened by carefully grinding as shown in Fig. 7.27(b). Use a free cutting wheel to avoid overheating and softening the scribing edge. Use an appropriate silicon carbide (green grit) wheel if the nib is tungsten carbide tipped.
- When sharpening the point of a dot punch or a centre punch, the punch is presented to the abrasive wheel as shown in Fig. 7.27(c). This ensures that the grinding marks run down the point as shown in Fig. 7.27(d) and not round it.
- Rules should be kept clean. The datum end should be protected and *never* used as a makeshift screwdriver or for shovelling swarf out of the T-slot of a machine tool bed. The edges of a rule must also be kept in a good condition if it is to enable straight lines to be scribed or it is to be used as a straight edge.

- Try-squares must also be treated carefully and cleaned and boxed when not in use. They should never be dropped, mixed with other tools or used for any purpose other than for which they are designed.
- Angle plates must be kept clean and free from bruises. Bruises not only prevent proper contact between the angle plate and the work it is supporting, they also cause damage to the surface of the marking-out table on which they are supported.
- Surface plates and marking-out tables must also be treated with care as they provide the datum from which other dimensions are taken.
- Vee blocks must be kept boxed in pairs as originally supplied. They are made in matched pairs and must be kept together for the whole of their working lives. Vee blocks from two different sets will not necessarily support a shaft parallel to the datum surface on which the blocks are supported.
- Table 7.1 summarizes the more usual causes of faults and inaccuracies when marking out.

TABLE 7.1 *Faults and inaccuracies when marking out*

<i>Fault</i>	<i>Possible cause</i>	<i>To correct</i>
Inaccurate measurement	Wrong instrument for tolerance required	Check instrument is suitable for tolerance required
Scribed lines out of position	Incorrect use of instrument	Improve your technique
	Parallax (sighting) error	Use the scriber correctly
Lines not clear	Rule not square with datum edge	Use a datum block (abutment)
	Scribing point blunt	Sharpen the point of the scriber
	Work surface too hard	Use a surface coating (spray-on lacquer)
	Scribing tool lacks rigidity	Use only good-quality tools in good condition
Corrosion along scribed lines	Protective coating (tin plate) cut by using too sharp a scribing point	Use a pencil when marking coated materials
Component tears or cracks along scribed line when bent	Scribed line and direction of bend parallel to grain of material	Bend at right angles to grain of the material
	Scribed line cut too deeply	Mark bend lines with a pencil
Circles and arcs irregular and not clear	Scribing points blunt	Resharpen
	Instruments not rigid	Use only good quality dividers or trammels of correct size for job
	Centre point slipping	Use a dot punch to make a centre location
Centre punch marks out of position	Incorrect use of punch	Position punch so that point is visible and then move upright when point is correctly positioned
	Scribed lines not sufficiently deep to provide a positive point location	Ensure point can click into the junction of the scribed lines

7.6.7 Cutting and limit lines

The concept of dot punching scribed lines to preserve them has already been introduced. Let's now examine this technique more closely. Scribed lines are often marked with a dot punch as shown in Fig. 7.28. Small dot punch or 'pop' marks are made along a straight line at about 20 mm intervals and at corners as shown in Fig. 7.28(a). They should be closer together around curves and complex profiles. Be careful to locate the point of the dot punch accurately on the scribed line when dot punching. If the scribed line should become defaced or erased, it can be restored using a scriber to connect the dot marks again.

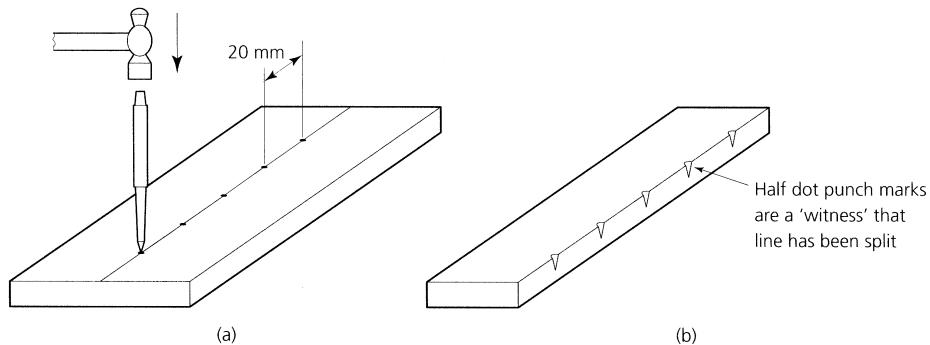


Figure 7.28 *Preserving a scribed line: (a) dot punching; (b) witness marks*

Another use for these 'pop' marks is as an aid to machining. If you machine down to a scribed line so as to 'split the line', there will be no line left to prove that you have worked accurately to the line. However, if the line has dot marks along it, and you have accurately split the line then half the marks are still visible to prove the accuracy of your work as shown in Fig. 7.28(b). For this reason such marks are often called *witness marks*.

7.6.8 Round holes – size and position

In theory all you need when marking out hole centres ready for drilling is a centre punch mark at the intersection of the centre lines as a guide for the drill point. Unfortunately drills have a habit of 'wandering' especially when starting a large drill with a centre punch mark. Therefore it is usual also to mark out the circle representing the hole, as shown in Fig. 7.29(a), using dividers. The hole is then dot punched. If the hole is drilled accurately, the dot punch marks should be split. However, this assumes that the:

- Centre lines are accurately marked out.
- Centre punch mark is exactly at the intersection of the centre lines.
- Dividers are exactly set to the hole radius.

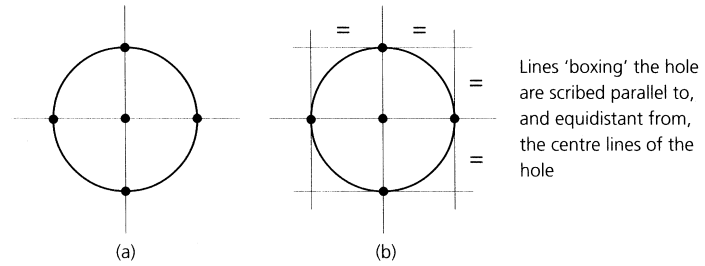


Figure 7.29 *Marking out round holes*

- Dividers do not 'wander' in the centre punch mark.
- 'Pop' marks around the circle are accurately positioned.

This is an awful lot of assumptions. For this reason it is better to 'box' the hole as shown in Fig. 7.29(b). Whilst the hole centres are being accurately marked out using rectangular co-ordinates, the vernier height gauge can also be used to accurately scribe lines either side of the centre lines at a distance equal to the radius of the hole. This produces an accurate box within which the drilled hole should lie.

7.6.9 Guide lines

Guide lines and witness lines are also used in conjunction with straight cutting lines as shown in Fig. 7.30. The guide line is scribed parallel to the cutting line or the limit line and it is positioned on the waste material side as shown in Fig. 7.30(a), therefore the guide line will be removed during machining. In the case of a drilled hole or a bore, the guide line is a circle slightly smaller than the finished size of the hole or bore. This is shown in Fig. 7.30(b).

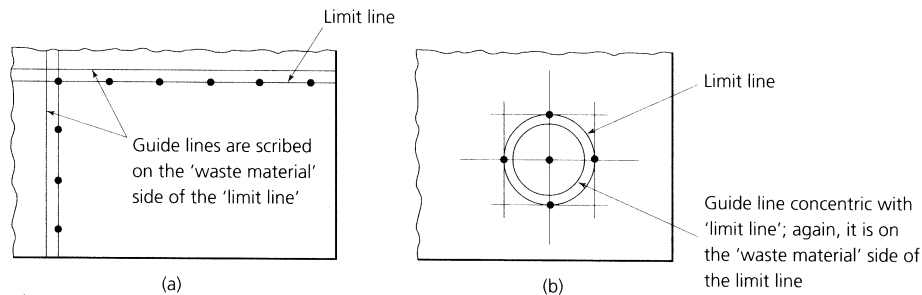


Figure 7.30 *Guide lines*

The reason for providing a guide line is to provide a visual check that the work is correctly set and that machining is being carried out parallel to the cutting line or the limit line. This enables adjustments and corrections

to be made before cutting to the final size. For this reason more than one guide line may be provided.

7.6.10 Witness lines

Witness lines are scribed parallel to the cutting or the limit line on the opposite side to the guide line as shown in Fig. 7.31. Therefore, when cutting is complete, they should still be present. They are used in conjunction with or in place of the dot punch witness marks described earlier. If cutting or machining has been successfully and correctly performed, the witness line should be parallel to the edge of the component and the correct distance from it. It remains as a witness to the accuracy of the fitting or machining processes used.

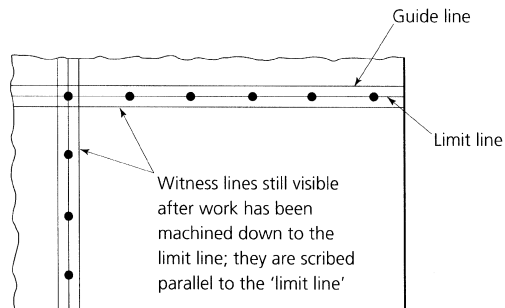


Figure 7.31 *Witness lines*

Witness lines are applied to a round hole on the opposite side of the limit line (outline) of the hole. That is, it will lie just outside the limit line, whilst the guide line (as previously described) will lie just inside the limit line. The circular or boxed lines can then act as a *witness* to the size and position of the drilled hole.

7.6.11 Line enhancement

The use of layout inks has already been discussed. However, their use can be messy and they tend to dissolve away with some coolants during cutting or be scratched away by the swarf during machining operations. For this reason it is sometimes better to enhance the line itself to give a colour contrast by rubbing one of the following substances into the scribed line.

- Engineer's blue will enhance the clarity of scribed lines on bright shiny metals.
- Chalk powder will enhance the clarity of scribed lines on dull dark metals such as grey cast iron.
- Graphite from crushed pencil leads can be used with good effect to enhance lines scribed on non-metallic materials.

Exercises 7.1 *Marking out and marking-out equipment*

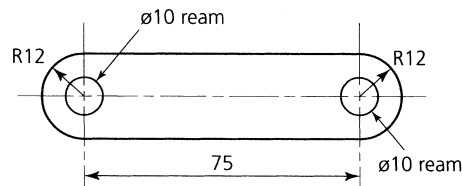
- (a)
 - (i) List the reasons for marking out components ready for manufacture.
 - (ii) Explain why mass produced components are not marked out prior to manufacture.
- (b) List the advantages and limitations of manual marking out in terms of accuracy and possible damage to the surfaces of the workpiece.
- (c) Complete Table 7.2. It has been started to give you a guide.

TABLE 7.2 *Exercise 7.1(c)*

<i>Technique</i>	<i>Equipment required</i>
Straight lines	Rule and scribe
Circles and arcs	—
Lines parallel to an edge (not using a surface plate)	—
Lines parallel to a surface plate	—
Lines parallel to angle sections	—
Lines along shafts parallel to each other and to the axis of the shaft	—
Lines perpendicular to an edge	—

7.2 *Techniques for marking out*

- (a) Draw up an operation schedule for marking out the component shown in Fig. 7.32, using its centre line as a datum. List the marking-out operations in the correct order and the equipment used.

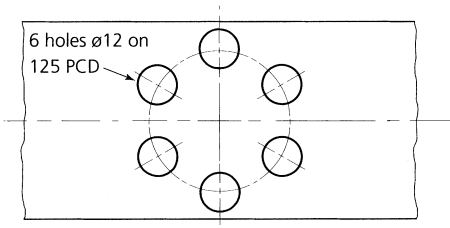
**Figure 7.32** *Exercise 7.2(a)*

- (b) With the aid of sketches explain how lines can be scribed parallel and perpendicular to a surface plate datum.
- (c) State the purpose of a box square and, with the aid of sketches, show how it can be used.
- (d) Describe the difference between a dot punch and a centre punch and explain their uses.

7.3 *Types of datum*

- (a) Copy and complete Table 7.3.

TABLE 7.3 *Exercise 7.3(a)*

Type of datum	Sketch of example
Edge of datum	
Line of datum	
	

- (b) With the aid of sketches, describe how the component shown in Fig. 7.33 can be marked out on a surface table using the edge marked AA as a datum.
- (c) With the aid of sketches describe how a scribed line can be 'protected' using dot punch marks. Also describe how these dot punch marks can act as a 'witness' to show that a fitter or a machinist has worked correctly to a scribed line.

7.4 *Minimizing inaccuracies when marking out*

- (a) Explain what is meant by the term *parallax errors* when marking out using a steel rule. How can such errors be minimized?
- (b) Describe two ways in which a scribed line can be made to show up more clearly.
- (c) Describe TWO ways (other than those in (a) and (b)) by which marking-out inaccuracies can be minimized.

7.5 *Care of marking-out tools and equipment*

- (a) With the aid of sketches describe how the scribing points/edges of the following marking-out tools should be sharpened:
- (i) divider points;
 - (ii) vernier height gauge nib;
 - (iii) dot punch point.

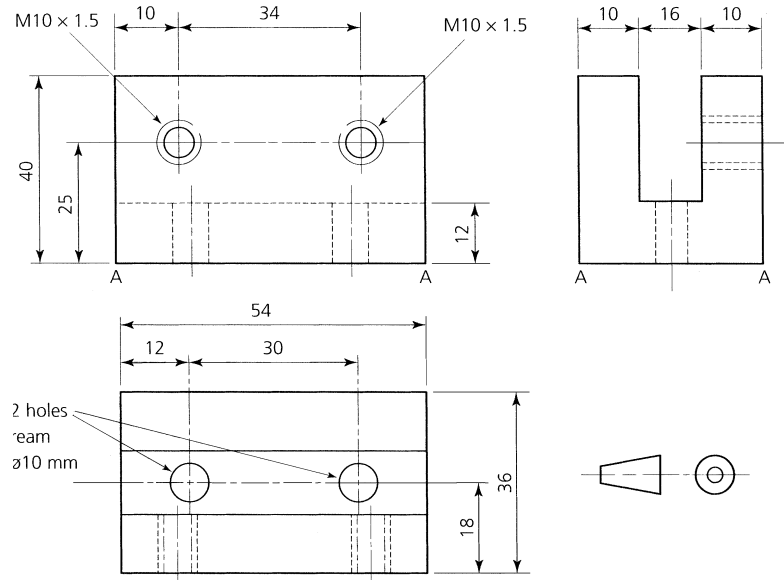


Figure 7.33 Exercise 7.3(b)

- (b) Describe how marking-out tools and measuring instruments should be cared for and stored in order to maintain their accuracy and to maintain them in good condition.

8 Basic bench fitting

When you have read this chapter you should understand:

- How to select suitable hand tools for particular jobs.
- How to prepare hand tools for safe and effective use.
- The principles of metal cutting.
- How to cut internal and external screw threads using taps and dies.
- How to apply the above techniques in the production of typical workpieces.

(Note: The sharpening of bench tools on the off-hand grinding machine will be dealt with in Chapter 12.)

8.1 Relative merits and disadvantages of using hand tools

Despite the wide range of machine tools available, and despite the high rates of material removal that are possible with modern machine tools and cutters, bench fitting using hand tools still has a place in modern industry. Bench fitting is too slow and costly for batch and flowline production, but it has a place in the making of ‘one-off’ prototypes for research and development projects, and in jig and toolmaking.

8.1.1 Merits

- Hand tools are relatively cheap and versatile for making small components of complex shapes that would be difficult to hold on machines.
- Small and delicate components may not be strong enough to withstand the clamping and machining forces, hand processes will then be the only choice.
- Skilled craftspersons can work to relatively high levels of accuracy and finish using hand tools.
- No capital investment in costly plant is required.
- Hand tools are more easily maintained compared with machine tool cutters.

8.1.2 Disadvantages

- Compared with machining, the rate of material removal by hand tools is limited and production using hand tools is relatively slow.

- Compared with machining processes such as surface and cylindrical grinding, the accuracy and finish achieved even by a skilled crafts-person are limited.
- The unit cost of production by using hand tools is high because of the limited rate of material removal and the relatively high wages that can be commanded by skilled fitters and toolmakers.

8.2 The fitter's bench

The term *fitting* covers those operations that the engineering craftsperson performs by hand at the bench. The production of accurate components by hand demands levels of skill that takes many years of constant practice to acquire. The basic requirement of successful fitting is a properly designed work bench. There is no single design for an ideal bench. However, for accurate work it is generally accepted that:

- The bench must be made from heavy timbers on a strongly braced metal frame so that it is as solid and rigid as possible.
- It must be positioned so that there is adequate natural lighting supplemented as required by adequate, shadowless, artificial lighting.
- The height of the bench should allow the top of the vice jaws to be in line with the underside of the fitter's forearm when held parallel to the ground.
- There should be adequate storage facilities for small tools and instruments.

8.2.1 The fitter's vice

A fitter uses a parallel jaw vice of the type shown in Fig. 8.1(a). It is often fitted with a quick-release device that frees the screw from the nut so that the vice can be opened or closed quickly. This saves time when changing

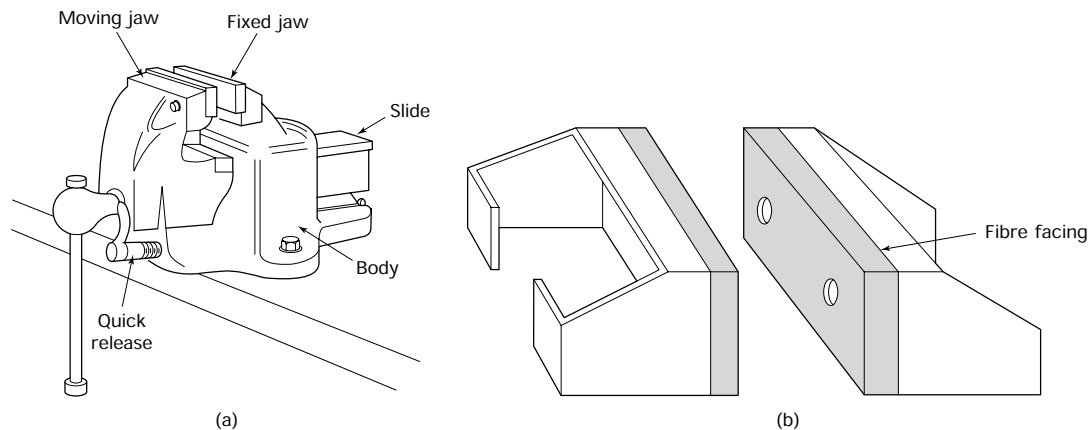


Figure 8.1 Fitter's vice (a), vice shoes (b)

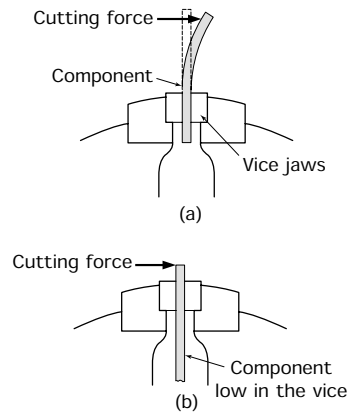


Figure 8.2 Positioning work in the vice: (a) incorrect – if the cutting force is applied too far from the vice jaws, it will have insufficient ‘leverage’ to bend the component; even when the force is too small to bend the component, it will make it vibrate and give off an irritating squealing noise; (b) correct – when the component is held with the least possible overhang, the cutting force does not have sufficient ‘leverage’ to bend the component or to make it vibrate

8.3 The metal cutting wedge

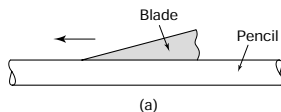


Figure 8.3 The clearance angle (β): (a) no clearance ($\beta = 0$) – the blade skids along the pencil without cutting; (b) clearance ($\beta > 0$) – the blade bites into the pencil and cuts

between wide and narrow work. For accurate work the vice must be kept in good condition as follows:

- Oil the screw and nut regularly.
- Oil the slideways regularly.
- Ensure that the vice is substantial enough for the work in hand.
- Heavy hammering and bending should be confined to the anvil and not performed on the vice.
- When chipping, the thrust of the chisel should be against the fixed jaw.
- Never hammer on the top surface of the slide.

8.2.2 Vice shoes

The jaws of a vice are serrated to prevent the work from slipping. However, these serrations can mark and spoil a finished surface. If the vice is to be used only for fine work and light cuts, the jaws can be surface ground flat and smooth. Alternatively, if the vice is going to be used for both rough and fine work, then vice shoes can be used. These can either be cast from a soft metal such as lead or they can be faced with fibre as shown in Fig. 8.1(b).

8.2.3 Using a vice

The vice should be securely bolted to the bench and should be positioned so that the fixed jaw is just clear of the edge of the bench. This allows long work to hang down clear of the bench. Work should be positioned in the vice so that the major cutting forces acting on the work are directed towards the fixed jaw. The work should always be held in a vice with a minimum of overhang as shown in Fig. 8.2. There is always a possibility that work protruding too far out of a vice will bend under the force of the cut. Also that the work will vibrate and produce an irritating squealing sound.

One of the first controlled cutting operations you performed must have been the sharpening of a pencil with a penknife. It is unlikely you will have received any formal instruction before your first attempt but, most likely, you soon found out (by trial and error) that the knife blade had to be presented to the wood at a definite angle if success was to be achieved. This is shown in Fig. 8.3.

If the blade is laid flat on the wood it just slides along without cutting. If you tilt it at a slight angle, it will bite into the wood and start to cut. If you tilt it at too steep an angle, it will bite into the wood too deeply and it will not cut properly. You will also find that the best angle will vary between a knife that is sharp and a knife that is blunt. A sharp knife will penetrate the wood more easily, at a shallower angle, and you will have more control. But look at that knife blade. It is the shape of a wedge. In

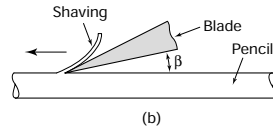


Figure 8.3 (continued)

8.4 The angles of a wedge-shaped cutting tool and their terminology

fact all cutting tools are wedge shaped (more or less), so let's now look at the angles of a typical metal cutting tool.

Having seen that a cutting tool is essentially wedge shaped, let's now see how this wedge shape affects the other cutting angles of a metal cutting tool.

8.4.1 Clearance angle

We have seen that for our knife to cut, we need to incline it to the surface being cut, and that we have to control this angle carefully for effective cutting. This angle is called the *clearance angle* and we give it the Greek letter 'beta' (β). All cutting tools have to have this angle. It has to be kept as small as possible to prevent the tool 'digging in'. At the same time it has to be large enough to allow the tool to penetrate the workpiece material. The clearance will vary slightly depending upon the cutting operation and the material being cut. It is usually about 5° to 7° .

8.4.2 Wedge angle

If, in place of our pencil, we tried to sharpen a point on a piece of soft metal (such as copper) with our knife we would find that the knife very quickly becomes blunt. If you examine this blunt edge under a magnifying glass, you will see that the cutting edge has crumbled away. To cut metal successfully, the cutting edge must be ground to a less acute angle to give it greater strength when cutting metal. This is shown in Fig. 8.4.

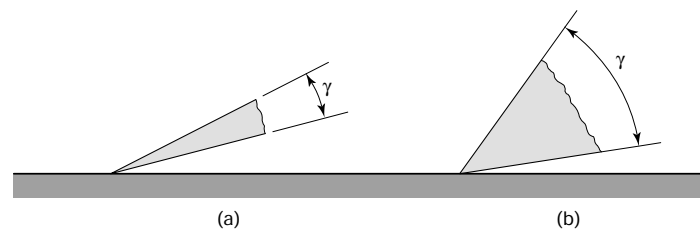


Figure 8.4 Wedge (tool) angle (γ): (a) blade sharpened for cutting wood; (b) blade sharpened for cutting metal

The angle to which the tool is ground is called the wedge angle or the tool angle and it is given the Greek letter 'gamma' (γ). The greater the wedge angle, the stronger will be the tool. Also, the greater the wedge angle the quicker the heat of cutting will be conducted away from the cutting edge. This will prevent the tool overheating and softening, and help to prolong the tool life. Unfortunately, the greater the wedge angle

is made, the greater will be the force required to make the tool penetrate the workpiece material. The choice of the wedge angle becomes a compromise between all these factors.

8.4.3 Rake angle

To complete the angles associated with cutting tools, reference must be made to the rake angle. This is given the Greek letter alpha (α). The rake angle is very important, for it alone controls the geometry of the chip formation for any given material and, therefore, it controls the mechanics of the cutting action of the tool. The relationship of the rake angle to the angles previously discussed is shown in Fig. 8.5.

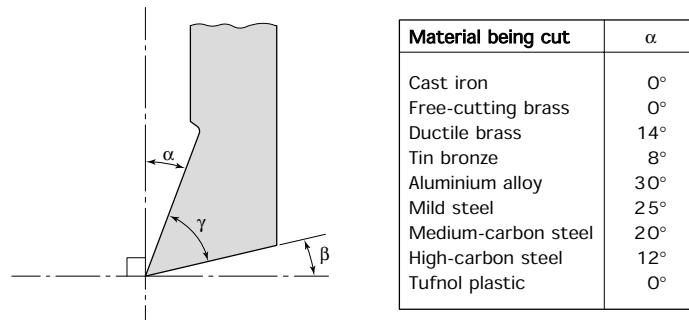


Figure 8.5 Cutting tool angles: α = rake angle; β = clearance angle; γ = wedge or tool angle

Increasing the rake angle increases the cutting efficiency of the tool and makes cutting easier. Since increasing the rake angle reduces the wedge angle, increased cutting efficiency is gained at the expense of tool strength. Again a compromise has to be reached in achieving a balance between cutting efficiency, tool strength and tool life.

So far only a single point tool with positive rake has been considered. Tools may also have neutral (zero) rake and negative rake. The meaning of these terms is explained in Fig. 8.6. It can be seen that the wedge angles

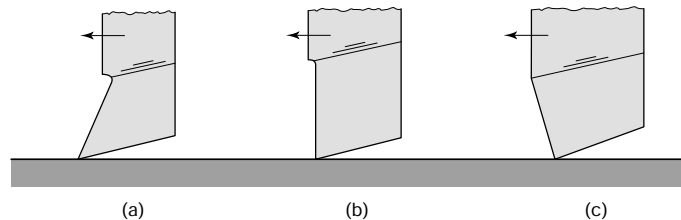


Figure 8.6 Rake angles: (a) positive rake; (b) neutral (zero) rake; (c) negative rake

for such tools is much more robust and it should come as no surprise that they are used for heavy cutting conditions. However, the cutting action of tools with neutral and negative rake angles is somewhat different to the positive rake geometry considered so far and is beyond the scope of this book.

8.5 The application of the basic cutting angles to hand tools

Let's now consider how the basic principles of the metal cutting wedge can be applied to a range of standard bench tools.

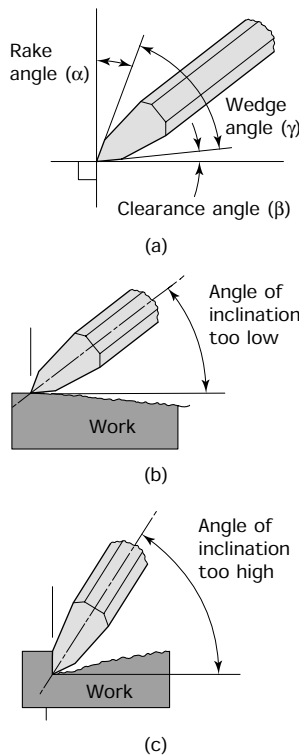


Figure 8.7 *The cold chisel*

8.5.1 Cold chisels

The basic wedge angle described above applies to all metal-cutting tools. Figure 8.7(a) shows how the point of a cold chisel forms a metal-cutting wedge with rake and clearance angles, and how the angle at which you present the chisel to the work (angle of inclination) affects the cutting action of the chisel.

In Fig. 8.7(b) the chisel is presented to the work so that the angle of inclination is too small. As a result, the rake angle becomes larger and the clearance angle disappears. This prevents the cutting edge of the chisel from biting into the work and the cut becomes progressively shallower until the chisel ceases to cut.

In Fig. 8.7(c) the chisel is presented to the work so that the angle of inclination is too large. As a result the effective rake angle becomes smaller and the effective clearance angle becomes larger. This results in the cutting edge of the chisel 'digging in' so that the cut becomes progressively deeper.

8.5.2 Files

Like any other cutting tool a file tooth must have correctly applied cutting angles. File teeth are formed by a chisel edge cutter so that the first or 'overcut' produces a single cut file or 'float' with the teeth at 70° to the edge of the file blank. Such files are not widely used except on soft materials such as copper and aluminium. The tooth form is less likely to become clogged up than the tooth form of the more commonly used double-cut file.

Most files have a second or 'up-cut' at 45° to the opposite side of the file blank so that the 'cuts' cross each other. Files manufactured in this manner are referred to as 'double-cut' files. Up-cutting gives the teeth a positive rake angle and a smoother cutting action. Double-cut files are suitable for use on tougher materials such as plain carbon steels and alloy steels. They are also suitable for use on cast iron and most non-ferrous metals.

8.5.3 Hacksaw blades

The teeth of a heavy duty hacksaw blade suitable for use on a power driven sawing machine is shown in Fig. 8.8(a). You will see that the

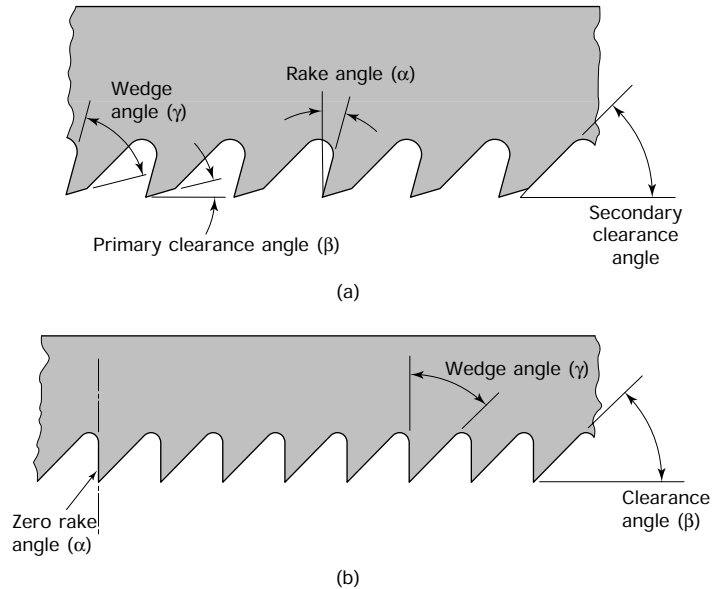


Figure 8.8 Hacksaw blade teeth: (a) heavy duty power saw blade – tooth form gives high strength coupled with adequate chip clearance; (b) light duty hand saw blade showing simplified tooth form used for fine tooth blades

teeth form a series of metal-cutting wedges. Since there are a series of metal-cutting edges this is called a *multi-tooth* cutting tool, compared with a chisel or a lathe tool which are called single-point cutting tools. Like all multi-tooth cutting tools designed to work in a slot, the power hacksaw blade has to be provided with chip (secondary) clearance as well as cutting (primary) clearance. The secondary clearance provides room for the chips to be carried out of the slot without clogging the teeth whilst, at the same time, maintaining a strong cutting edge.

The finer teeth of a hand saw blade have only a simple wedge shape as shown in Fig. 8.8(b). Chip clearance is provided by exaggerating the primary clearance. Although this weakens the teeth, their strength is adequate for a hand saw. In addition side clearance has to be provided to prevent the blade binding in the slot being cut. This is done by providing the teeth with a ‘set’, as described in Section 8.9.

8.6 Chipping

Chipping is the removal of metal by the use of cold chisels. The cutting action of a cold chisel has already been discussed. Now let’s look at the chipping process. This process is used for rapidly breaking down a surface. It is the quickest way of removing metal by hand but the accuracy is low and the finish is poor. However, in some instances there are no alternatives. Figure 8.9 shows a selection of cold chisels and some typical chipping operations.

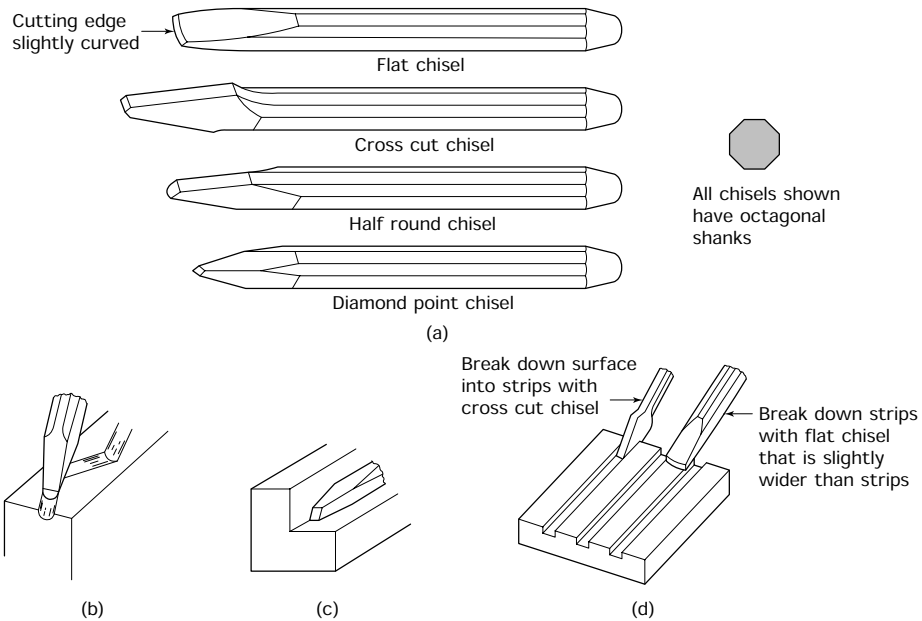


Figure 8.9 Cold chisel types (a) and uses: (b) cutting an oil groove with a half-round chisel; (c) squaring out a corner with a diamond point chisel; (d) chipping a flat surface

Safety – When using a cold chisel:

- Do NOT chip towards your workmates.
- Always use a chipping screen (Fig. 8.10).
- Always wear goggles to protect your eyes from the flying splinters of metal (Fig. 8.10).

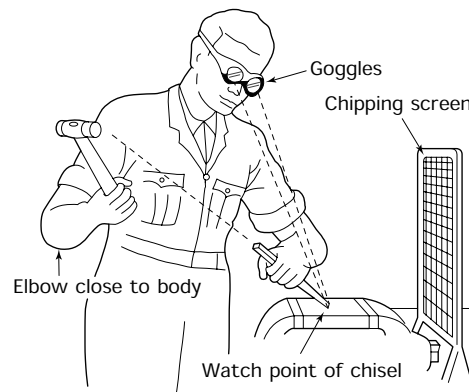


Figure 8.10 Safety when using a cold chisel

8.7 Hammers

In the previous section, we saw that hammers were used to drive the chisel through the material being cut. There are various types and sizes of hammer used by fitters, and the parts of a hammer are shown in Fig. 8.11(a). The most commonly used type of hammer is the ball-pein hammer as shown in Fig. 8.11(b).

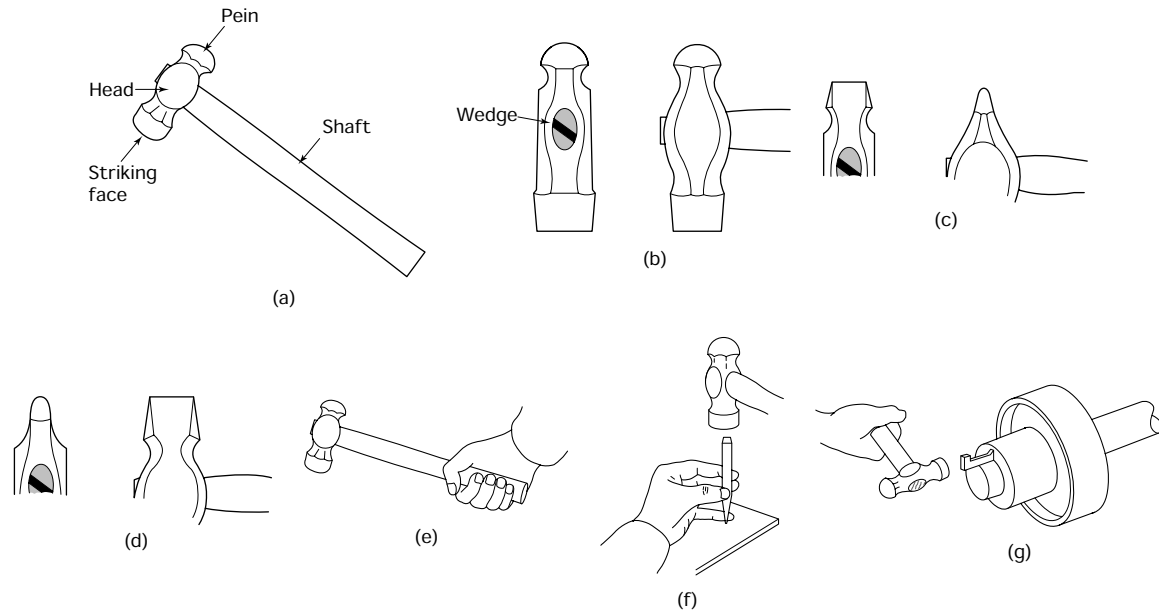


Figure 8.11 Hammer construction (a), ball pein type (b), cross pein type (c), straight pein type (d), correct grip (e), used with another tool (f), used directly (g)

If a hammer is too big, it will be clumsy to use and proper control cannot be exercised. If a hammer is too small it has to be wielded with so much effort that, again, proper control cannot be exercised. In both these instances the use of the incorrect size of hammer will result in an unsatisfactory job, possible damage to the work and possible injury to the user. Before using a hammer you must check it to make sure of the following:

- The handle (shaft) is not split.
- The head is not loose.
- The head is not cracked or chipped.
- Never 'strangle' a hammer by holding it too near the head. It should be held as shown in Fig. 8.11(e).
- A hammer is usually used to strike other tools such as chisels, drifts and centre punches as shown in Fig. 8.11(f).

You must be careful when a hammer is used to strike a component, such as a key or a dowel, directly (Fig. 8.11(g)) so that the component being struck is not bruised. Soft-faced hammers should be used when machined surfaces have to be struck. Soft-faced hammers are faced with various materials such as soft metals like brass and aluminium and non-metals such as plastic and rawhide. Some are made from solid rubber moulded onto the handle. However, these tend to bounce and it is difficult to deliver a dead blow. An improved design is hollow and loosely filled with lead shot. This type of rubber mallet will deliver a dead blow and also provide the protection against bruising of the solid rubber type. Alternatively a soft metal (brass, copper or aluminium) drift should be placed between the hammer head and the component being struck.

8.8 Filing

Filing operations can range from roughing down to fine and accurate finishing operations. There is a wide variety of files, and to specify any given file you must state the length, shape and grade of cut. The main features of a typical file are shown in Fig. 8.12.

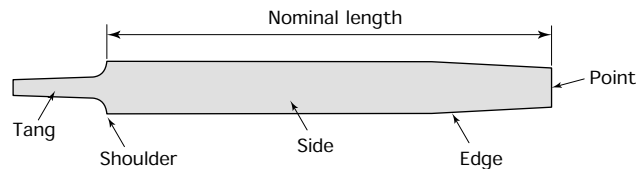


Figure 8.12 *Engineer's file*

8.8.1 Grade or cut

The *grade* or cut of a file depends upon its length. A long second-cut file can have a coarser cut than a short bastard-cut file. The most common cuts are:

- *Bastard cut* – general roughing out.
- *Second cut* – roughing out tough materials such as die steels and for finishing on less tough materials.
- *Smooth cut* – general finishing of precision components and for draw filing.

8.8.2 Types of file

The *shape* of the file selected is governed by its application. Figure 8.13 shows some of the more commonly used files and typical applications.

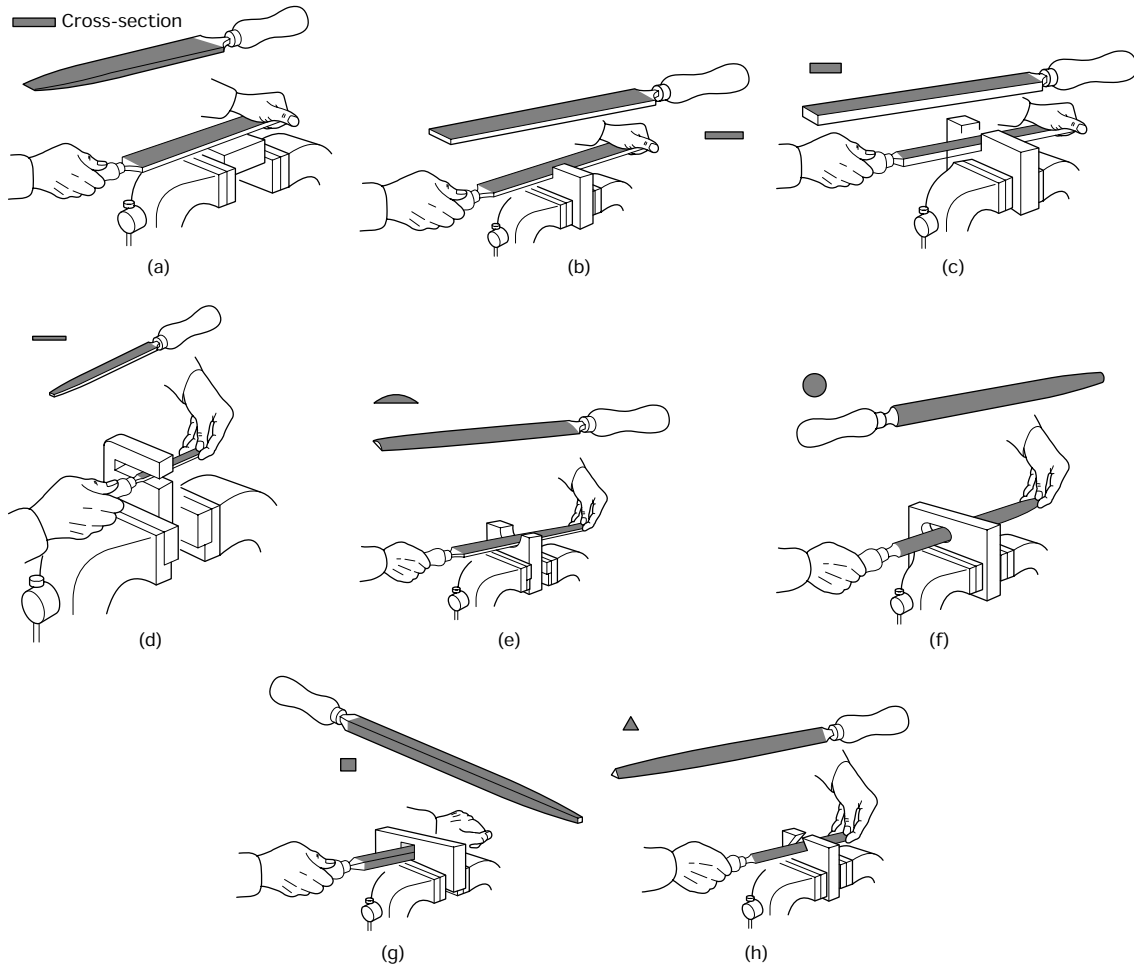


Figure 8.13 Types of file and their applications: (a) flat file; (b) hand file; (c) pillar file; (d) ward file; (e) half-round file; (f) round file; (g) square file; (h) three-square file

Flat file

A flat file is shown in Fig. 8.13(a). It tapers for the last third of its length and the last third of its thickness. It is double cut on both faces and single cut on both edges. It is used for the general filing of flat surfaces.

Hand file

A hand file is shown in Fig. 8.13(b). It is parallel in width but tapers slightly in thickness. It is double cut on both faces and is single cut on one edge only. The other edge is left smooth and is called a *safe edge*.

Pillar file

A pillar file is shown in Fig. 8.13(c). It is similar to a hand file but is narrower, thicker and does not taper. It is useful for work in narrow slots. Because of its thickness it is able to withstand a greater downward pressure and because it is narrower than a hand file it can 'bite' more readily into the metal.

Warding file

A warding file is shown in Fig. 8.13(d). It is similar in shape to a flat file but smaller and thinner, and it does not taper in thickness. It gets its name from the fact that it was originally used to file the slots between the 'teeth' or *wards* of keys for locks. It is used for filing flat surfaces in narrow slots.

Half-round file

A half-round file is shown in Fig. 8.13(e). Despite its name, it is not semi-circular in section. It is a segment of a circle. Half-round files are double cut on their flat side for general filing, but are single cut on the curved side. They taper in width and thickness for the last third of their length. Half-round files are used for filing concave surfaces and for working into corners.

Round file

A round file is shown in Fig. 8.13(f). This type of file is circular in cross-section and tapers for the last third of its length. Round files are used for opening out circular holes and for rounding internal corners. They are all single cut in the smaller sizes.

Square file

A square file is shown in Fig. 8.13(g). It is square in cross-section and tapers on all sides for the last third of its length. It is usually double cut on all four sides. It is used for filing square and rectangular holes, slots and grooves.

Three-square file

A three-square file is shown in Fig. 8.13(h). It is triangular in cross-section with all its angles at 60° . It is double cut on all three sides and tapers for the last third of its length. It is used for filing corners between 60° and 90° . For angles less than these either a half-round file or a knife-edge file has to be used.

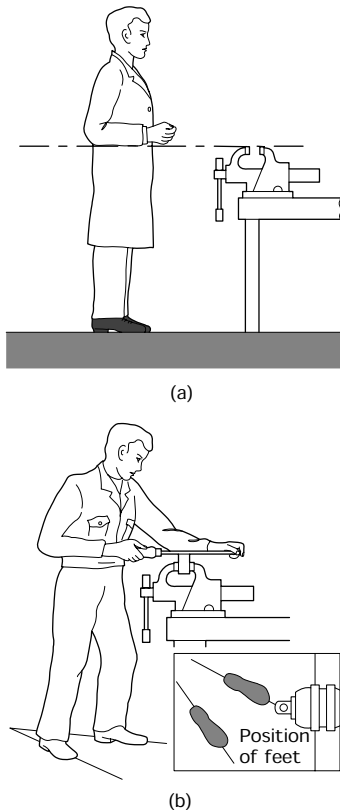


Figure 8.14 Use of a file:
(a) top of the vice should be in line with forearm held parallel to the ground; (b) position of feet and balance

8.8.3 Use of a file

A file can be controlled only if the fitter's body is correctly positioned and balanced. It has already been stated that the vice jaws should be at elbow height for convenience when fitting. This is particularly true when filing. Figure 8.14(a) shows the correct height of the vice and Fig. 8.14(b)

shows the correct position for your feet and the way your body should be balanced.

Equally important is the way the file is held. During each stroke, the weight must be gradually transferred from the front hand to the hand gripping the file handle. If this is not done correctly the file will rock and a flat surface will not be produced. Figure 8.15 shows how a file should be held for various operations.

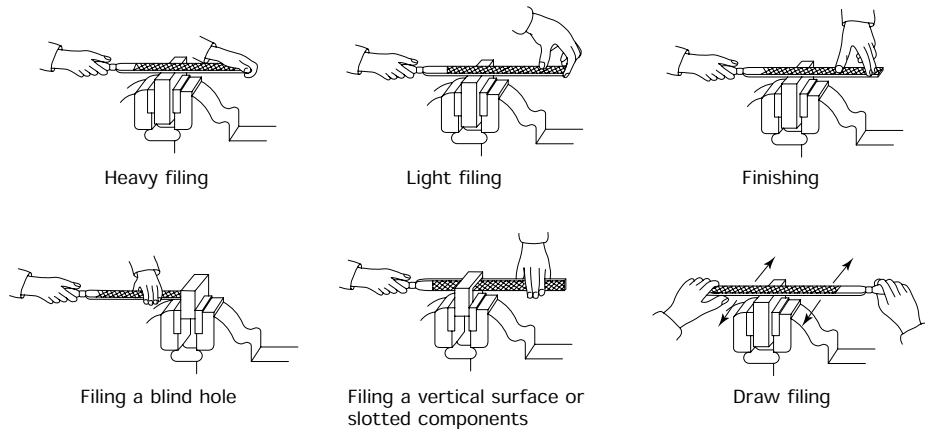


Figure 8.15 *Correct grip for different file applications*

8.8.4 Care of files

Files should be treated with care. Files that are badly treated are hard to use and leave a poor finish and poor accuracy.

- Keep all files in a suitable rack. Do not jumble them up in a draw or keep them with other tools as this will chip and damage the teeth.
- Keep your files clean with a special wire brush called a *file card*. Bits of metal trapped in the teeth reduce the rate of metal removal and score the surface of the work.
- Never use new files on steel. This will chip the teeth and make the file useless. Always 'break in' a new file on softer and weaker metals such as brass or bronze.
- Never file quickly, this only wears out the file and the user. Slow, even strokes using the full length of the file are best.
- Files cut only on the forward stroke. The downward pressure should be eased on the return stroke to reduce wear on the teeth. Do not lift the file off the work on the return stroke. Keeping the file in contact with the work helps to remove the particles of metal that lie between the teeth and also maintains your balance and rhythm that are essential to the production of a flat surface.

8.8.5 Safety when filing

When filing:

- Always ensure that the file is fitted with the correct size of handle and that the handle is secured to the file. Never use a file without a handle. The tang can easily stab into your wrist causing serious damage leading to the paralysis of your fingers.
- A badly fitted handle or the wrong size of handle reduces your control over the file causing you to slip and have an accident.
- A split handle does not protect you from the tang of the file.

8.9 The hacksaw

Figure 8.16(a) shows a typical engineer's hacksaw with an adjustable frame that will accept a range of blade sizes. For the best results the blade should be carefully selected for the work in hand. It must be correctly fitted and correctly used.

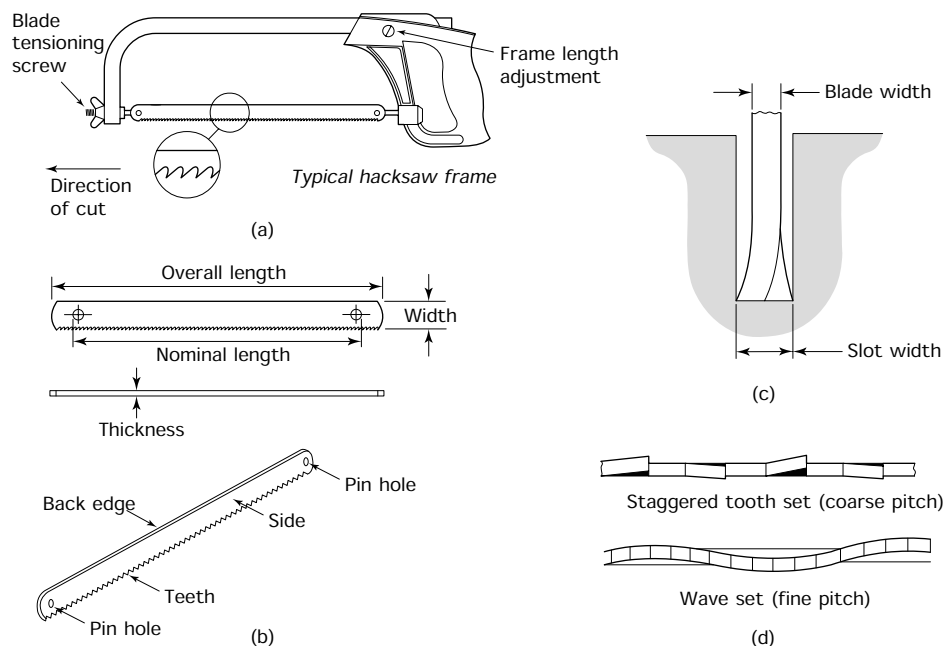


Figure 8.16 The hacksaw and its blades: (a) engineer's hacksaw showing typical hacksaw frame; (b) hacksaw blade; (c) the effect of set; (d) types of set

Figure 8.16(b) shows the main features and dimensions of a hacksaw blade. The essential cutting angles have already been discussed in Section 8.5.3. To prevent the blade jamming in the slot that it is cutting,

side clearance must be provided by giving the teeth of the blade a *set* as shown in Fig. 8.16(c).

There are two ways in which set may be applied. For coarse pitch blades for general workshop use, the teeth are bent alternatively to the left and right with each intermediate tooth left straight to clear the slot of swarf. Some blades leave every third tooth straight. For fine tooth blades used for cutting sheet metal and thin walled tubes, the edge of the blade is given a 'wave' set. Both types of set are shown in Fig. 8.16(d).

8.9.1 Hints when sawing

- The coarser the pitch of the teeth the greater will be the rate of metal removal and the quicker the metal will be cut. However, there must always be a minimum of three teeth in contact with the metal as shown in Fig. 8.17(a).

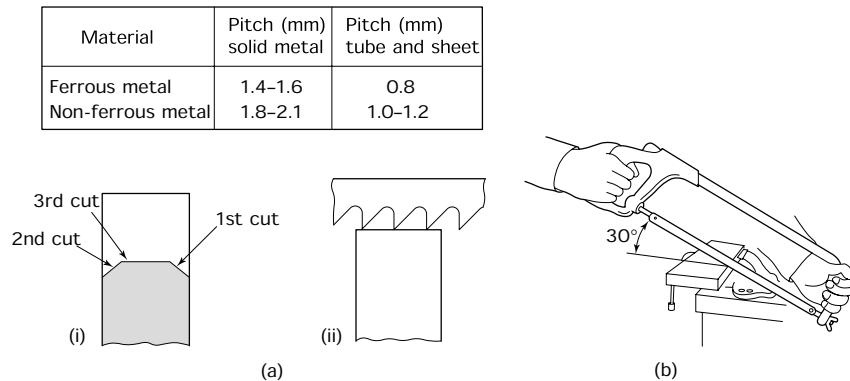


Figure 8.17 The hacksaw blade: (a) blade selection – (i) a wide component should be broken down in a series of short cuts; (ii) the pitch of the blade should be chosen so that at least three teeth are in contact with the workpiece all the time; (b) use of a hacksaw

- Thick material should be broken down into shorter surfaces as shown in Fig. 8.17(b).
- 'Rigid' or 'all-hard' high-speed steel blades give the best results but tend to break easily in unskilled hands. 'Flexible' or 'soft-back' blades are best for persons who are not yet fully skilled.
- The teeth of the blade should face the direction of cut and the blade should be correctly tensioned. After the slack has been taken up, the wingnut should be given at least another full turn.
- The rate of sawing should not exceed 50 to 60 strokes per minute.
- The correct way to hold and use a hacksaw is shown in Fig. 8.17(b).
- With use, the blade gradually loses its set and the slot cut will become narrower. For this reason never use a new blade in the slot started by an old blade. It will jam and break. Always start a new cut with a new blade.

8.9.2 Sawing sheet metal

The depth to which a hacksaw can cut is limited to the depth of the frame. Long narrow cuts are often required in sheet metal and, for this purpose, the blade can be turned through 90° as shown in Fig. 8.18(a). It is not so easy to exert downward force on the blade with the saw in this position, but this is not so important when cutting sheet material of limited thickness.

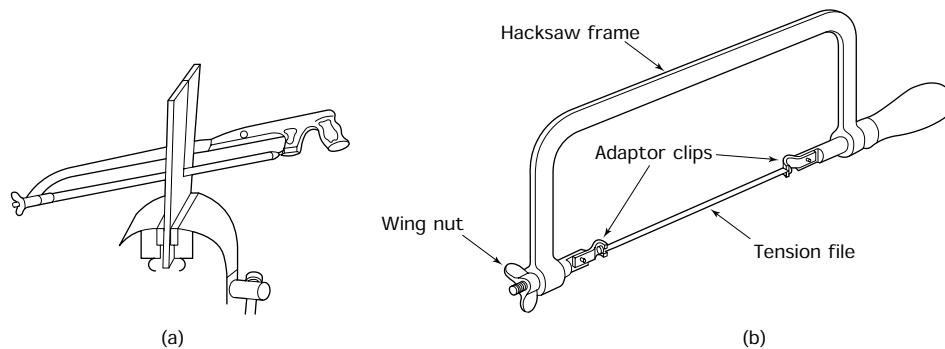


Figure 8.18 Cutting sheet metal: (a) the blade turned through 90° to cut sheet metal; (b) tension file – when the wingnut is tightened, the frame distorts and is put in a state of stress; in trying to spring back to its original shape it exerts a tensile (pulling) force on the blade or file, which is now in a state of tension

An ordinary hacksaw blade is useless for cutting profiles and, for this purpose, a tension file should be used. This is a long, thin, round file that is kept in tension by the saw frame as shown in Fig. 8.18(b). It is held in the frame by means of adapter clips.

8.10 Screw thread applications

In this book we are concerned only with threads with a V-form. Figure 8.19 shows a typical screw thread and names its more important features.

- The *major diameter* of the thread is the maximum diameter measured over the tops of the threads.
- The *nominal diameter* of the thread is the diameter by which it is known and specified. For most practical purposes it can also be considered to be the same as the major diameter.
- The *pitch (simple effective) diameter* is, as its name suggests, the diameter at which the pitch of the thread is measured. It is also the diameter at which the thickness of the external thread and the thickness of the internal thread are equal.
- The *pitch* is the distance from a point on one thread to an identical point on the next thread.
- The *thread angle* is the angle of the 'V' that gives the thread its form.

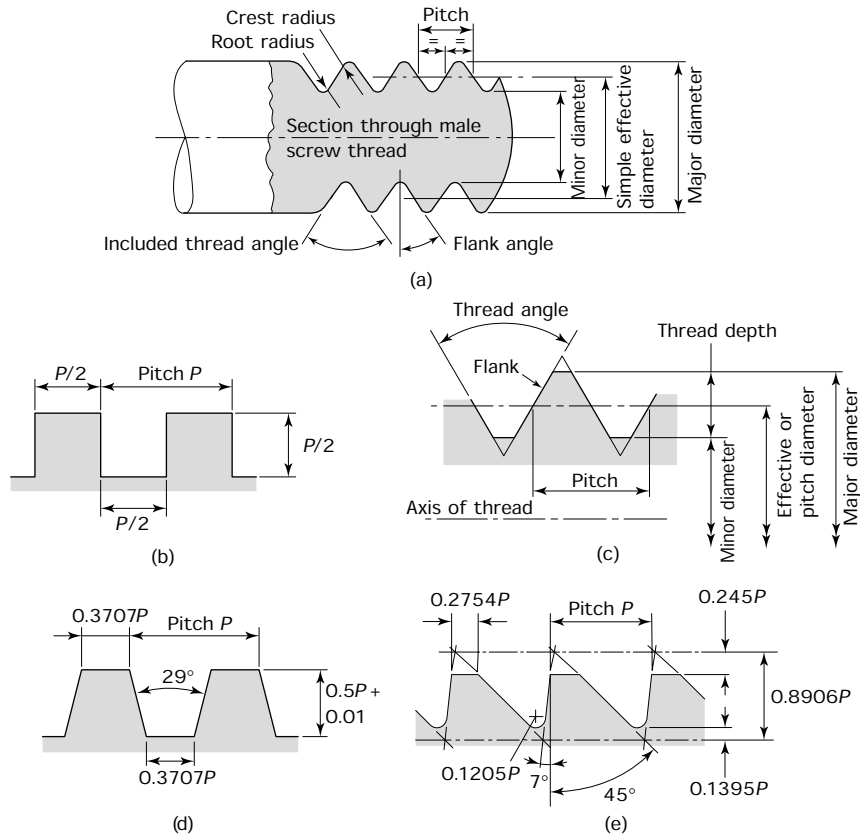


Figure 8.19 Screw thread elements

- The *root* is the bottom of the thread – usually radiused.
- The *crest* is the top of the thread – it may be radiused or it may be flat.
- The *flank* is the side of the thread. Only the flanks of the threads should make contact.

8.10.1 Specifying screw threads

To identify a screw thread the following information must be specified.

- *The nominal diameter.* This is stated in metric or inch units.
- *The pitch or the TPI.* For metric threads the actual pitch size is stated in millimetres. For inch units the number of *threads per inch* (TPI) is stated.
- *The type of thread form.* There are various types of thread form and, although metric screw threads should be specified for all new

equipment, the older thread forms are still widely used mainly for maintenance purposes.

Let's now consider the V-thread forms that are available to us.

Unified thread form

This has a 60° thread angle and is dimensioned in inch units. It is the basis of unified coarse threads (UNC) and unified fine threads (UNF); these threads originated in the USA but are also used in the UK. A typical example would be specified as $3/8$ -24 UNF indicating that the thread is unified fine, $3/8$ " nominal diameter, 24 threads per inch.

ISO metric thread form

This is the same as the *unified form* but is dimensioned in millimetres. A typical example would be $M10 \times 1.50$ indicating that the thread has a metric form (M), that its nominal diameter is 10 mm and that the pitch of the thread is 1.50 mm.

British Association (BA) thread form

This was originally introduced for the small threaded fasteners used in instruments and later was widely used in electrical equipment. It has a $47\frac{1}{2}^\circ$ thread angle and is dimensioned in millimetres. The largest thread is 0 BA which has a nominal diameter of 6.00 mm and a pitch of 1 mm. The smallest is 25 BA which has a nominal diameter of 0.25 mm and a pitch 0.07 mm. For new equipment this thread system should be replaced with the ISO miniature thread system.

Whitworth thread form

This has a 55° thread angle and is dimensioned in inch units. It is the basis of British Standard Whitworth (BSW), British Standard Fine (BSF), and British Standard Pipe (BSP) threads. A typical example would be specified as $1/2" \times 12$ BSW indicating that the thread is to British Standard Whitworth form, with a nominal diameter of $1/2$ inch, there are 12 threads per inch (TPI). Although the first standardized screw thread system in the world, it is now obsolete.

8.10.2 Screw thread applications

Some typical threaded fasteners and their applications are shown in Fig. 8.20. Note how the joint line of a bolted joint lies across the plain shank of the bolt. It should never lie across the threads. Normal nuts and bolts have *right-hand* threads. With right-handed threads the bolt moves into the nut when it is rotated in a *clockwise* direction. With *left-handed* threads, the bolt moves into the nut when rotated in an *anticlockwise* direction. An example is the double-ended off-hand grinding machine. The nut securing the right-hand grinding wheel has a right-hand thread.

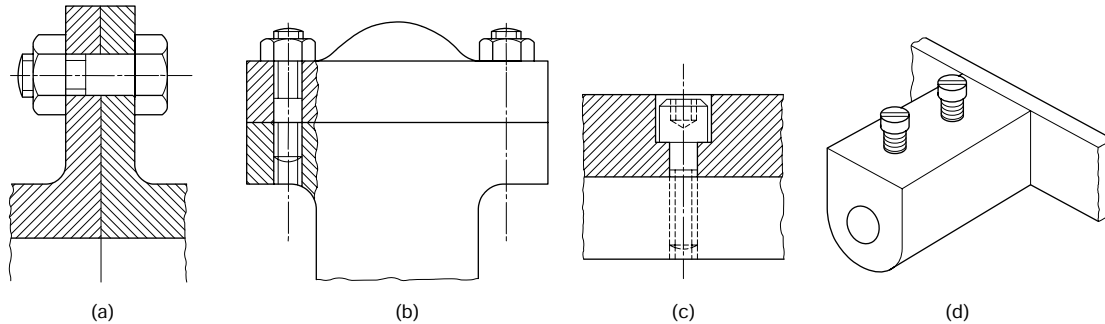


Figure 8.20 Use of screwed fastenings: (a) section through a bolted joint – plain shank extends beyond joint face; (b) stud and nut fixing for an inspection cover – this type of fixing is used where a joint has to be regularly dismantled; the bulk of the wear comes on the stud, which can be eventually replaced cheaply which prevents the wear falling on the expensive casting or forging; (c) cap head socket screw – although much more expensive than an ordinary hexagon head bolt, the socket screw is made from high tensile alloy steel, heat treated to make it very strong, tough and wear resistant; socket screws are widely used in the manufacture of machine tools and this example shows how the head may be sunk into a counterbore to provide a flush surface; (d) cheese head brass screws – these are used in small electrical appliances for clamping cables into terminals

The nut securing the left-hand grinding wheel should have a left-hand thread. This is so that the sudden snatch that occurs when the machine is turned on does not loosen the retaining nuts. Think about it!

As well as fastening things together, screw threads are used to change rotary motion into linear motion and this was discussed earlier (see square threads and acme threads). Screw threads can also provide dimensional control. The micrometer caliper uses a screw and nut as a measuring device. The micrometer dials on machine tool handwheels work in conjunction with their respective lead screws and nuts to provide dimensional control.

8.11 Cutting internal screw threads (use of taps)

Figure 8.21(a) shows a section through a thread-cutting tap and how rake and clearance angles are applied to a thread-cutting tap. Since the ‘teeth’ are *form relieved*, the clearance face is curved and the *clearance angle* is formed by the tangent to the clearance face at the cutting edge. The rake angle is formed by the flute, so we still have our metal-cutting wedge. Figure 8.21(b) shows a typical thread-cutting tap and names its more important features. Figure 8.21(c) shows a set of three taps.

- The *taper* tap is tapered off for the first 8 to 10 threads and is used first. The taper helps to guide the tap into the previously drilled tapping size hole with its axis parallel to the axis of the hole. The taper also helps to increase the depth of cut gradually and helps to prevent overloading the teeth.
- The *intermediate* or *second* tap has only 3 to 4 threads tapered to guide it into the threaded hole started by the taper tap. This tap can

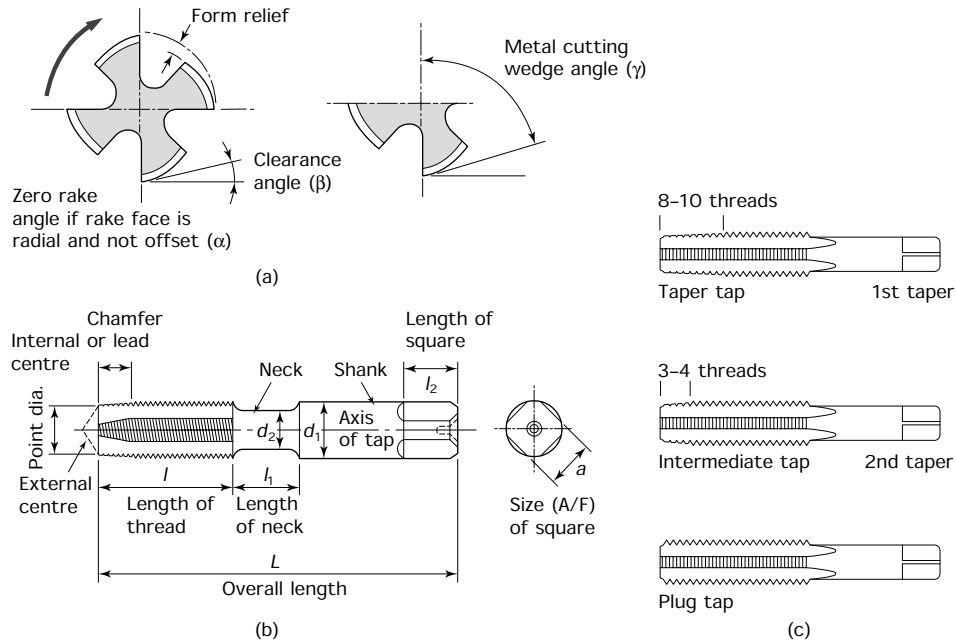


Figure 8.21 Screw thread taps: (a) cutting angles applied to a thread cutting tap; (b) nomenclature for taps; (c) set of thread cutting taps

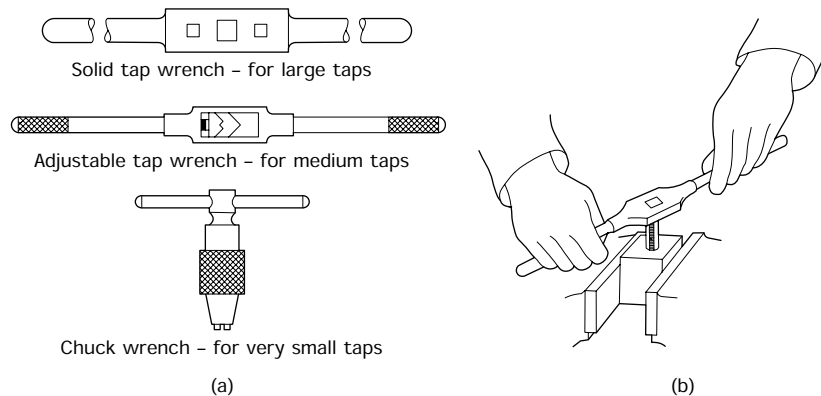


Figure 8.22 Tap wrenches: (a) types of tap wrench; (b) use of tap wrench

be used to finish threading a through hole. It also helps to cut full threads near to the bottom of a blind hole.

- The *plug* tap does not have any tapered threads and is used for cutting a full thread to the bottom of a blind hole.

Thread-cutting taps are rotated by means of a tap wrench. Various types of tap wrench are shown in Fig. 8.22(a) and Fig. 8.22(b) shows how a

tap wrench should be used. The tap is rotated in a clockwise direction and it should be reversed every one or two revolutions to break up the swarf. It is essential to start and keep the axis of the tap parallel to the axis of the hole. Normally this means that the axis of the tap will be at right angles to the work as shown. If the tap is started at an angle other than a right angle, the tap will cut more heavily on one side of the hole than on the other. At best this will produce a drunken thread, at worst it will cause the tap to break off in the hole. It is usually impossible to remove a broken tap and the work is scrapped.

Before you can cut an internal screw thread, you have to decide on the size of the hole to be used. Theoretically this should be the same as the *minor diameter* of the thread to be cut. In practice, the hole is always somewhat larger in diameter than the minor diameter for the following reasons.

- A thread with 80% engagement is adequate for most general engineering purposes. This considerably eases the load on the tap which is a fragile cutting tool that is easily broken if overloaded.
- The nearest standard drill size available. A smaller one cannot be used or the tap will jam and break, so the nearest larger size has to be used.

Published sets of workshop tables provide information regarding tapping drill sizes. Table 8.1 shows part of such a screw thread table. To cut an $M10 \times 1.5$ metric thread the table recommends the use of an 8.50 mm diameter drill to give the 80% engagement or an 8.60 mm diameter drill if 70% engagement would be adequate. Compare these sizes with the minor diameter of this thread which is 8.376 mm (minimum).

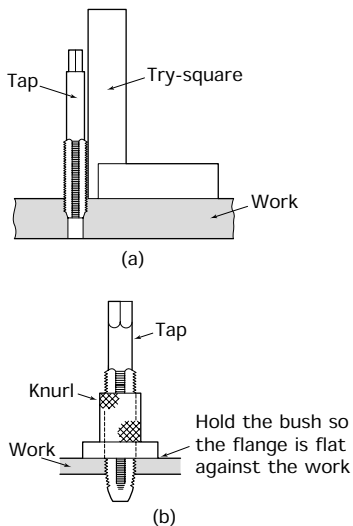


Figure 8.23 Starting the tap: (a) checking a tap with a try-square to ensure it is aligned with the hole; (b) use of a bush to start a small tap

8.11.1 Hints when tapping holes

- Make sure the taps are sharp and in good condition (no chipped or missing teeth) or they will jam and break off in the hole scrapping the job.
- Use a cutting compound that has been formulated for thread cutting. Lubricating oil is useless since it cannot withstand the cutting forces involved.
- Select the correct size of tap wrench to suit the size of the tap you are using. The wrong size will inevitably lead to a broken tap. A range of tap wrenches should be available.
- Make sure the tap is at right angles to the surface of the component. Figure 8.23(a) shows a large tap being checked with a try-square. Figure 8.23(b) shows a method of ensuring a small tap is started in line with the hole. Unfortunately you will need to make a guide bush for each size of tap. However, you will most likely find that you keep using a small range of sizes on a regular basis. The hole through the bush is not threaded but is a precision clearance fit on the tap simply to give guidance.

TABLE 8.1 *Screw thread data*

<i>ISO metric tapping and clearance drills, coarse thread series</i>					
<i>Nominal size</i>	<i>Tapping drill size (mm)</i>		<i>Clearance drill size (mm)</i>		
	<i>Recommended 80% engagement</i>	<i>Alternative 70% engagement</i>	<i>Close fit</i>	<i>Medium fit</i>	<i>Free fit</i>
M1.6	1.25	1.30	1.7	1.8	2.0
M2	1.60	1.65	2.2	2.4	2.6
M2.5	2.05	2.10	2.7	2.9	3.1
M3	2.50	2.55	3.2	3.4	3.6
M4	3.30	3.40	4.3	4.5	4.8
M5	4.20	4.30	5.3	5.5	5.8
M6	5.00	5.10	6.4	6.6	7.0
M8	6.80	6.90	8.4	9.0	10.0
M10	8.50	8.60	10.5	11.0	12.0
M12	10.20	10.40	13.0	14.0	15.0
M14	12.00	12.20	15.0	16.0	17.0
M16	14.00	14.25	17.0	18.0	19.0
M18	15.50	15.75	19.0	20.0	21.0
M20	17.50	17.75	21.0	22.0	24.0
M22	19.50	19.75	23.0	24.0	26.0
M24	21.00	21.25	25.0	26.0	28.0
M27	24.00	24.25	28.0	30.0	32.0
M30	26.50	26.75	31.0	33.0	35.0
M33	29.50	29.75	34.0	36.0	38.0
M36	32.00	–	37.0	39.0	42.0
M39	35.00	–	40.0	42.0	45.0
M42	37.50	–	43.0	45.0	48.0
M45	40.50	–	46.0	48.0	52.0
M48	43.00	–	50.0	52.0	56.0
M52	47.00	–	54.0	56.0	62.0

8.12 Cutting external screw threads (use of dies)

Figure 8.24(a) shows how the basic cutting angles are applied to a thread-cutting button die. You can see that a die has rake, clearance and wedge angles like any other cutting tool. Figure 8.24(b) shows the main features of a button die, whilst Fig. 8.24(c) shows a typical diestock that is used to rotate the die. Figure 8.24(d) shows how the die is positioned in the diestock.

Screw thread dies are used to cut external threads on engineering components. The split button die shown in Fig. 8.24 is the type most widely used by a fitter. The diestock has three adjusting screws. The centre screw engages the slot in the die and spreads the die to reduce the depth of cut. The other two screws close the die and increase the depth of cut. As for a tap the die must be started square with the work axis as shown in Fig. 8.25(a). It is difficult to control a screw-cutting die and any attempt to cut a full thread in one pass will result in a ‘drunken’ thread. It is better

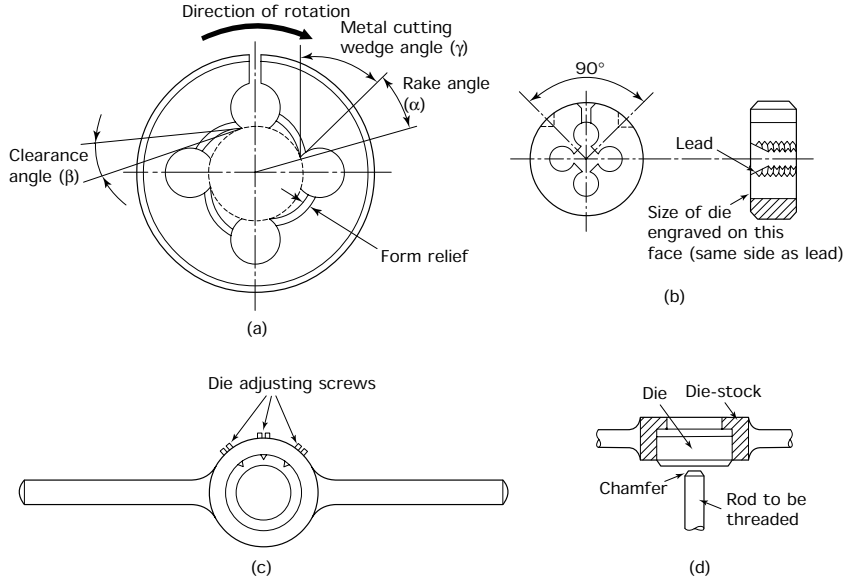


Figure 8.24 Split button dies: (a) cutting angles applied to a thread-cutting die; (b) split die; (c) diestock; (d) positioning of die in stock – the engraved face of the die is visible, ensuring that the lead of the die is in the correct position

to open up the die to its fullest extent for the first cut. (This will also produce a better finish on the thread.) Then close the die down in stages for the subsequent cuts until the thread is the required size. The thread size can be checked with a nut. The diestock is rotated in a clockwise direction and should be reversed after every one or two revolutions to break up the swarf. A thread-cutting lubricant must be used.

8.12.1 Miscellaneous thread-cutting devices

Rectangular loose dies

These dies are also used but are less common than button dies. They have a bigger range of adjustment but require a special type of diestock – an example is shown in Fig. 8.25(b).

Die nut

Die nuts, as shown in Fig. 8.25(c), are used for cleaning up bruised threads on existing bolts and studs when carrying out maintenance work. They are not adjustable.

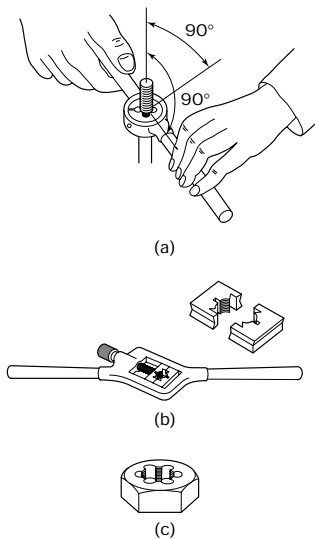


Figure 8.25 Screw thread dies: alignment and further types: (a) diestock must be aligned with the axis of the work; (b) rectangular split dies; (c) solid die nut

8.12.2 Hints when using screw-cutting dies

- The die has its size and the manufacturer’s name on one face only. This is the face that should show when the die is in the stock. This

will ensure that the taper lead of the die will engage with the end of the work.

- A chamfer on the end of the work will help to locate the die.
- Start with the die fully open and gradually close it down to the required size in successive cuts.
- Select the correct size of stock for the die. This is largely controlled by the diameter of the die. A range of diestocks should be available.
- Use a cutting compound that has been formulated for thread cutting.

8.13 Hand reamers and reaming

When producing a hole with a twist drill, that hole will invariably have a poor finish, be out-of-round and be oversize. These faults can be overcome by drilling the hole very slightly undersize and correcting it for finish, roundness and size by *reaming*. This can be done by hand at the bench using a hand reamer rotated by a tap wrench or in a drilling machine or lathe using taper shank machine reamers. Reamed holes are usually used for fitting dowels when building up assemblies. Note that dowels only provide location, they are not fasteners.

Figure 8.26 shows a typical parallel hand reamer and names its main features. Hand reamers are rotated by means of a tap wrench and they are rotated in a clockwise direction. When withdrawing the reamer it must continue to be turned in the same direction. *It must not be reversed*. A reamer will always follow the original hole. It *cannot* be used to correct the *position* of a hole. An adjustable reamer is used when a hole of non-standard diameter has to be sized.

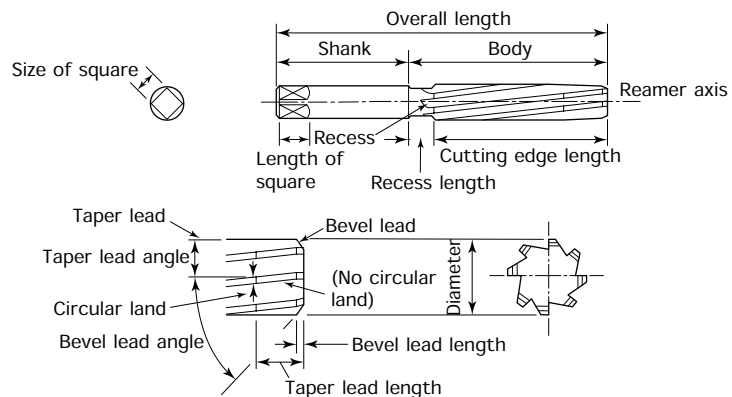


Figure 8.26 Hand reamer

8.13.1 Hints when reaming

- Use a suitably formulated cutting compound, lubricating oils are not suitable for reaming.

- Always turn the reamer clockwise. Never reverse it.
- Reamed dowel holes should always be ‘through’ holes so that the dowel can be knocked out from the reverse side when the assembly has to be dismantled.
- Leave the minimum of metal in the drilled hole to be removed by the reamer. A reamer is only a finishing tool.
- The dowel should be a light drive fit. There is a saying: ‘Never use the biggest hammer in the shop to drive a dowel in, since you may need an even bigger one to knock it out.’

8.13.2 Taper pin reamers

Figure 8.27(a) shows typical taper pin reamers. These are used for producing tapered holes in components that require to be locked in place by a tapered pin as shown in Fig. 8.27(b). For this purpose a tapered pin is preferable to a parallel dowel since it locks up tight as it is driven home and is retained by its wedging action. However, it is immediately released when driven back in the opposite direction. Any wear in the hole caused by repeated dismantling and assembly is compensated for by the pin merely having to be driven into the hole a little deeper.

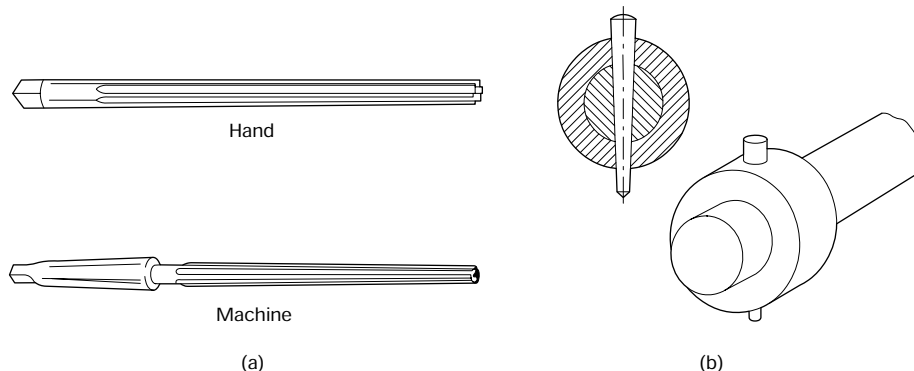


Figure 8.27 *Taper pin reamers and their use: (a) taper pin reamers; (b) a collar secured to a shaft by means of a taper pin*

8.14 Tools used in assembly and dismantling

Another and very important aspect of the fitter’s work is the assembly and dismantling of engineering equipment.

8.14.1 Screwed fastenings

Screwed fastenings are most widely used by bench fitters during the assembly or the dismantling of engineering equipment. Examples of joining techniques using threaded (screwed) fastenings were shown previously in Fig. 8.20.

8.14.2 Locking devices for screwed fastenings

Locking devices are employed to prevent threaded fastenings from slackening off in use as a result of vibration. Some examples of locking devices are shown in Fig. 8.28. You will see that they are divided into two categories. Those which depend upon friction and those where the locking action is positive. Positive locking devices are more time consuming to fit, so they are used only for critical joints where failure could cause serious accidents, for example the control systems of vehicles and aircraft.

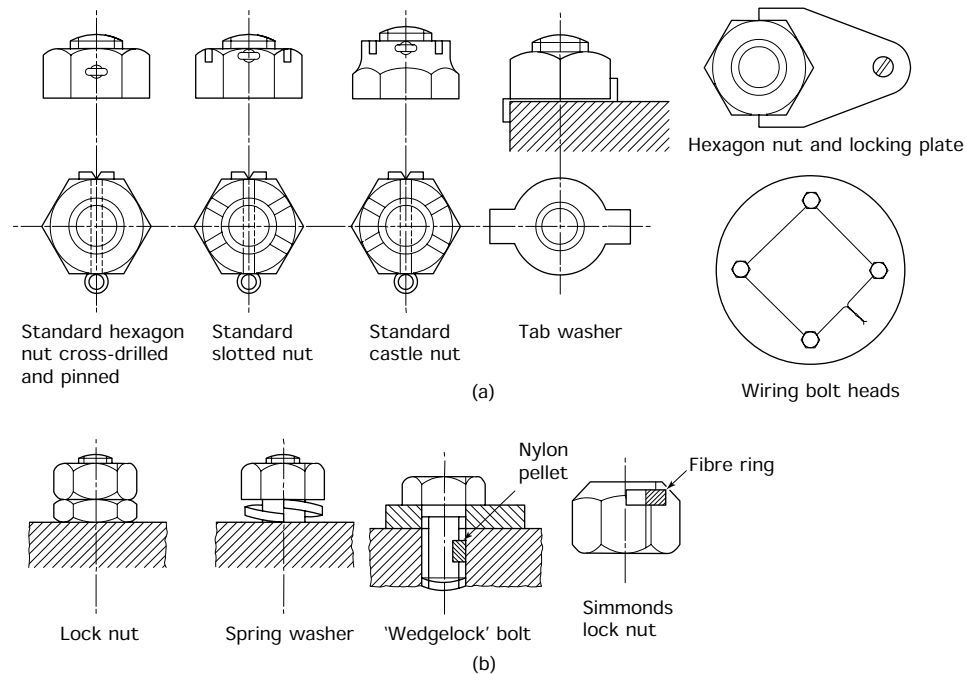


Figure 8.28 Locking devices for screwed fastenings: (a) positive locking devices; (b) friction locking devices

8.14.3 Spanners and keys

To turn the nut or the bolt you have to use various types of spanners, keys and wrenches. Spanners are proportioned so that the length of the spanner provides sufficient leverage for a person of average strength to be able to tighten the fastening correctly. A spanner must not be extended to get more leverage. Extending the spanner will overstress the fastening and weaken it. Further, it will also damage the spanner jaws so that they will not fit properly and this can give rise to injuries. Figure 8.29 shows the correct way to use spanners.

8.14.4 Screwdrivers

Screwdrivers must also be chosen with care so that they fit the head of the screw correctly. A variety of screwdrivers and their correct application are shown in Fig. 8.30.

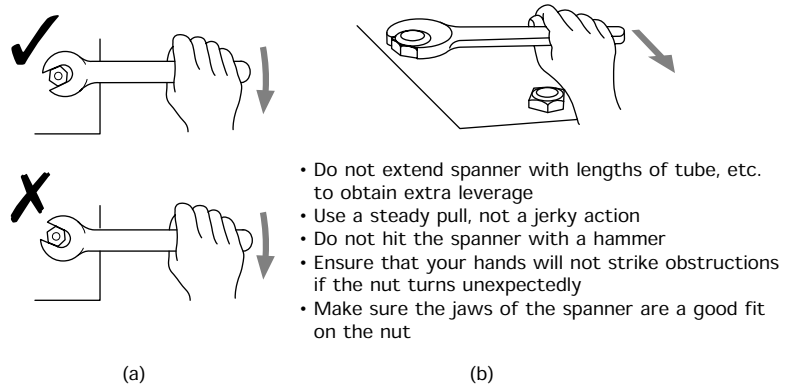


Figure 8.29 Correct use of spanners: (a) when tightened correctly, the force exerted on the spanner tends to keep the jaws on the nut; used wrongly, the jaws tend to slip off the nut; (b) pull towards your body whenever possible

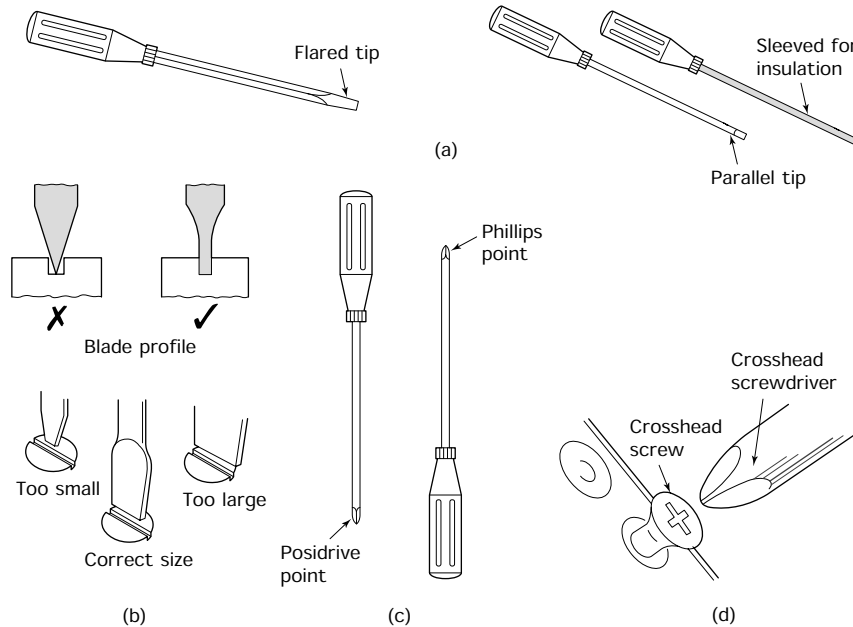


Figure 8.30 Screwdrivers: (a) types of flat blade screwdriver; (b) correct selection of screwdriver blade; (c) types of crosshead screwdriver; (d) the correct size and type of crosshead screwdriver must always be used for crosshead (recessed head) screws

8.14.5 Pliers

Pliers are also used for assembly and dismantling operations where they are useful for holding small components and for inserting and removing

split pins. Pliers with special jaws are used for removing circlip type fastenings. A selection of pliers and their uses are shown in Fig. 8.31. On no account should pliers be used for tightening or loosening hexagon nuts and bolts.

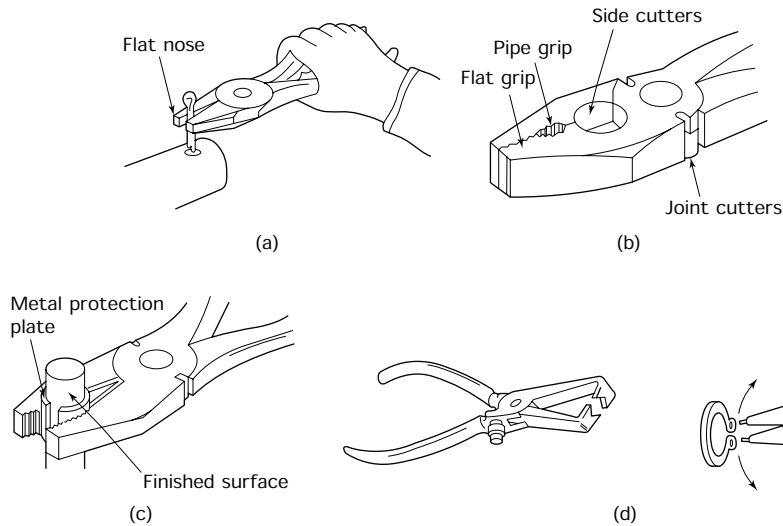


Figure 8.31 Pliers: (a) flat nose pliers; (b) combination pliers; (c) protecting finished surfaces; (d) circlip pliers

8.14.6 Miscellaneous fixing and locating devices

Dowels

Threaded fastenings such as screws, bolts and nuts are usually inserted through clearance holes. The exception being ‘fitted’ bolts which have turned or ground shanks and are inserted through reamed holes. Where clearance holes are used it is necessary to use parallel dowels to provide a positive location between two components. The dowel is manufactured to be a light drive fit in a reamed hole. It is given a slight taper lead so that as it is driven into the hole the metal of the component expands slightly and that of the dowel compresses slightly. The elastic ‘spring-back’ holds the dowel rigidly in place and ensures positive location. Dowels are case hardened and ground, not only for precision, but to prevent them ‘picking up’ as they are driven into their holes.

Taper pins

Taper pins are used for fastening components such as collars or handles onto shafts. When the collar or handle has been correctly located on the shaft, a parallel hole is drilled through the component and the shaft. This hole is then opened up using a taper pin reamer of the appropriate size.

The taper pin is then driven home in the tapered hole. A typical example was shown in Section 8.13.2.

Cotter pins

Cotter pins are taper pins with a screw thread at the smaller end. They are secured by the thread and nut that also pulls the cotter tightly against its seating. One side of the cotter has a flat which engages with a flat on the shaft to provide a positive drive. A typical example is the fixing of the pedal crank of a bicycle as shown in Fig. 8.32(a).

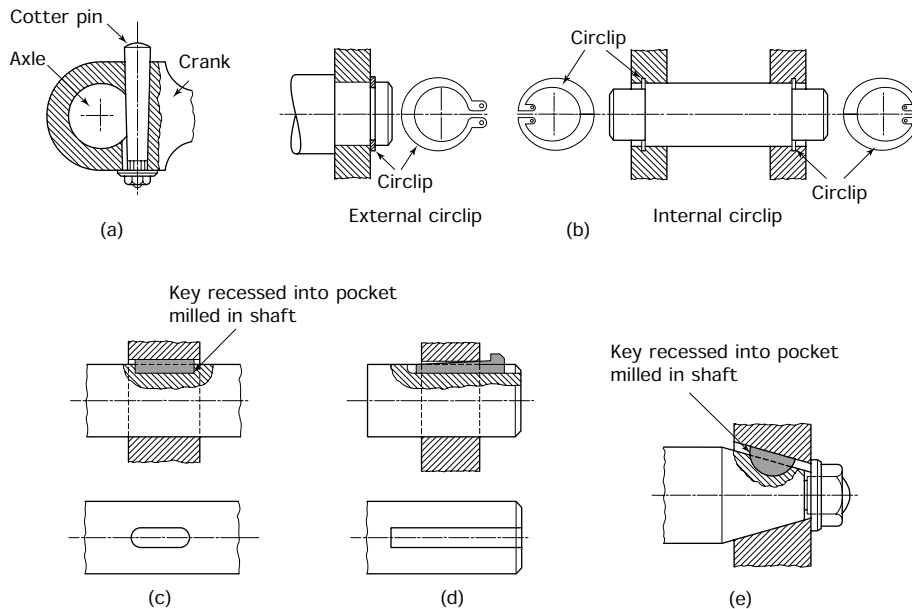


Figure 8.32 *Miscellaneous fixings: (a) cotter pins; (b) circlips; (c) feather key; (d) gib-head key; (e) Woodruff key*

Circlips

These are spring steel clips used for locating components against a shoulder as shown in Fig. 8.32(b). The clips can be opened or closed for fitting by specially shaped pliers that fit into the holes in the lugs at the end of the clips.

Feather key

This type of key fits into a pocket milled into a shaft. It transmits rotational movement between the shaft and the wheel. Generally the pocket is end milled as shown in Fig. 8.32(c). This enables the key and the wheel or other device it is driving to be positioned at any point along a shaft. The

key is fitted only on its width and is clearance on its depth. It drives only the wheel or other device and these have to be secured to the shaft positionally by some arrangement such as a set screw.

Gib-head (tapered) key

This type of key is driven into a slot that is cut half into the wheel and half into the shaft. It transmits rotational movement between the shaft and the wheel. Being tapered, the key can be driven in tight and is secured by the spring-back of the metal to form a mechanical compression joint. The wheel, or other device, is secured by friction only, although the drive is positive. For safety, a positive fixing device is also provided. An example of a gib-head key is shown in Fig. 8.32(d) and it can be seen that such a key can be fitted only when the wheel it is driving is mounted on the end of a shaft. The key can be removed by driving a wedge between the wheel hub and the gib-head of the key.

Woodruff key

This is fitted into a segmental socket that is milled into the shaft. It transmits rotational movement between the shaft and the wheel. Since the key can 'float' it is self-aligning and is widely used in conjunction with tapered mountings as shown in Fig. 8.32(e). A special milling cutter is used to cut the pocket in the shaft. The key is used to provide a positive drive. It does not secure the wheel or other device on the shaft. In the example shown, you can see that a nut is used to secure the wheel in place.

8.14.7 Levers and supports

Levers in the form of crowbars (pinch bars) are widely used for raising heavy objects manually (Fig. 8.33(a)). Levers depend upon the *principle of moments* for their force magnification as shown in Fig. 8.33(b). The greater the distance of the effort from the pivot point (fulcrum), the greater will be the lifting force applied to the load. Similarly, the smaller the distance between the load and the pivot point the greater will be the force applied to the load.

Figure 8.33(c) shows two types of pinch bar (crowbar) and their correct use. *Never* use a brittle packing material, such as a brick, for the fulcrum. This can collapse without warning leading to an accident. Wood is the best material since the bar will bite into the wood and this prevents the bar from slipping. Also, if the load is too great, you can see the bar starting to sink into the wood and you can release the load in a controlled manner so as to prevent an accident. Metal is the strongest packing but there is always the danger of the bar slipping on it.

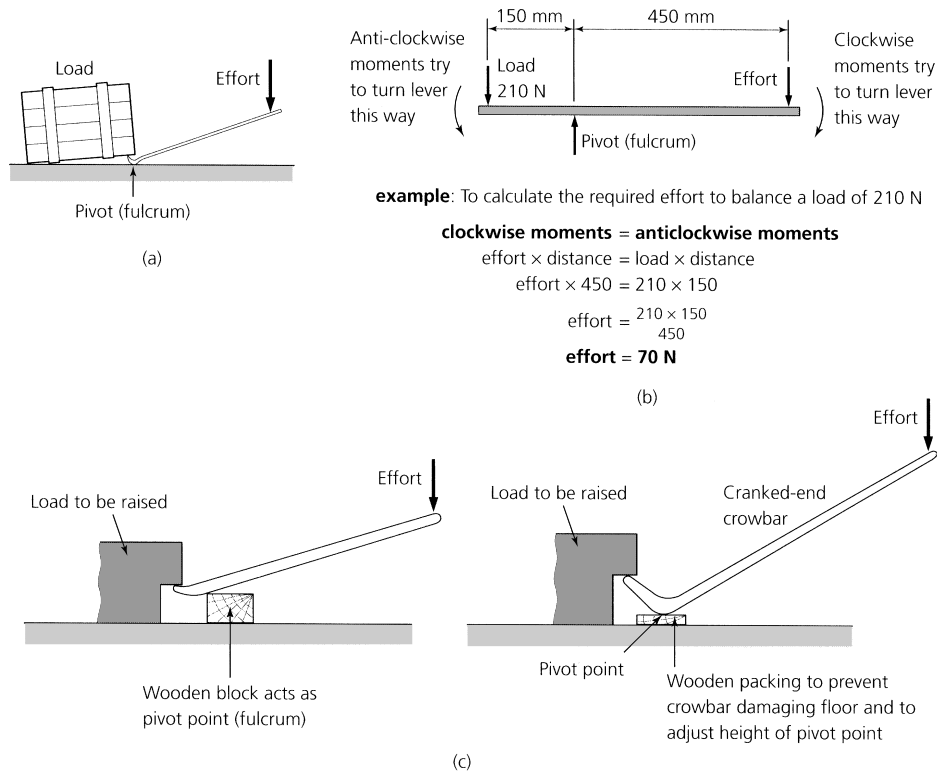


Figure 8.33 Levers (crowbars) and supports: (a) crowbar; (b) principle of moments applied to a lever – if the effort is less than 70 N the lever will rotate in an anticlockwise direction; if the effort is greater than 70 N the lever will rotate in a clockwise direction; (c) use of crowbars

Press down on the bar with the flat of your hand. Never wrap your fingers round it. If the bar slipped, your fingers would be trapped between the bar and the floor and your fingers would be broken and crushed.

Never work under equipment that is suspended from a hoist. Always lower the equipment onto suitable supports before commencing work as was shown in Fig. 1.25.

8.15 Preparation of hand tools

Before using hand tools they should be checked to see if they are fit and safe for use.

- Files should be checked to see if the handle is properly fitted on the tang, that the handle is not split, and that the handle is a suitable size for the file.
- Files should be checked to see if the teeth are clean. If there are particles of metal between the teeth they should be removed with a file card. If the teeth have a glazed or shiny appearance, the file will be blunt and should be exchanged for one in better condition.

- Hacksaw blades should be checked for missing teeth and lack of set; they should be securely mounted in the saw frame and correctly tensioned. There should be no twist in the blade.
- Hammer heads must be secure and undamaged. They must not be cracked or chipped. The shaft of a hammer must not be split or damaged.
- Chisels must have sharp cutting edges and be correctly ground. The head of the chisel must not be ‘mushroomed’. If it is ‘mushroomed’ the head of the chisel must be dressed on an off-hand grinding machine to restore its correct shape before use.
- Never use defective equipment: report it immediately to the appropriate person.

Note: The double-ended off-hand grinding machine and its use will be discussed in Chapter 12.

8.16 Making a link

Let’s now consider the manufacture of the link previously introduced in Section 7.6 when discussing marking-out techniques. This time we are going to consider its manufacture. Table 8.2 lists the operations for two alternative ways of producing this link.

TABLE 8.2 *Making the link*

<i>Method 1</i>	<i>Method 2</i>
1. Set up for drilling whilst sides of blank are still parallel	1. Set up for drilling whilst sides of blank are still parallel
2. Drill pilot holes	2. Drill pilot holes
3. Drill for reaming	3. Drill for reaming
4. Ream to size	4. Ream to size
5. Remove surplus metal with hacksaw or band saw leaving minimum metal to clean up	5. Remove surplus metal by chain drilling and chiselling
6. File smooth	6. File smooth
7. Deburr	7. Deburr
8. Check	8. Check
9. Grease up	9. Grease up

Note: The marking out of the link has already been described in *Fundamentals of Engineering*. This table is concerned with the manufacture of the link.

A common mistake is to rush into cutting out the component from the stock material as the first operation. A little thought will show that once this component is cut out, it will be very difficult to hold in a vice for drilling the holes. That is why the operation sequence given in Table 8.2

recommends that all drilling operations are done first. Figure 8.34 shows a suitable drilling set-up. Since the link is relatively thin compared with the diameter of the holes it is advisable to drill a 6 mm diameter pilot hole and then open up the hole in two steps to the required 18 mm diameter, and three steps for the 25 mm diameter hole. Further, because the plate is relatively thin compared with the diameter of the holes, there will be a tendency for the larger drills to chatter and leave a rough finish and a hole that is not truly round. Therefore it is advisable to drill the holes 0.5 mm under size and finish them with a reamer using a suitable cutting fluid. Drilling and machine reaming operations are considered in detail in Chapter 9.

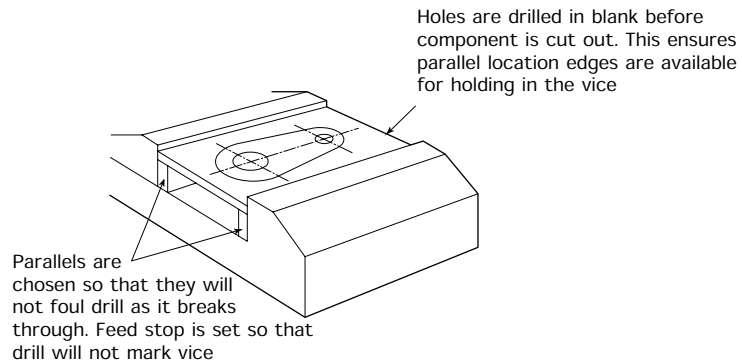


Figure 8.34 *Drilling the link*

Table 8.2 gives the options of:

- Sawing away the surplus material round the blank.
- Chain drilling and chiselling.

For a component of this size and shape there is little to choose between the two methods. However, had the material been thicker, then chain drilling and chiselling would have been the better way. Figure 8.35 shows the additional holes that would have had to be drilled whilst the blank was still set up for drilling and reaming the two large holes.

Figure 8.36(a) shows how the surplus metal is removed by using a chisel to break through the webs between the drilled holes. Note that as for any chipping operations the following precautions must be observed.

- Wear safety glasses or goggles.
- Do not chip towards another person.
- Place a chipping screen in front of your vice.

Figure 8.36(b) shows the problems that can occur when the material is thick and shows how the problems can be overcome by using a special chisel made from a piece of worn-out power hacksaw blade.

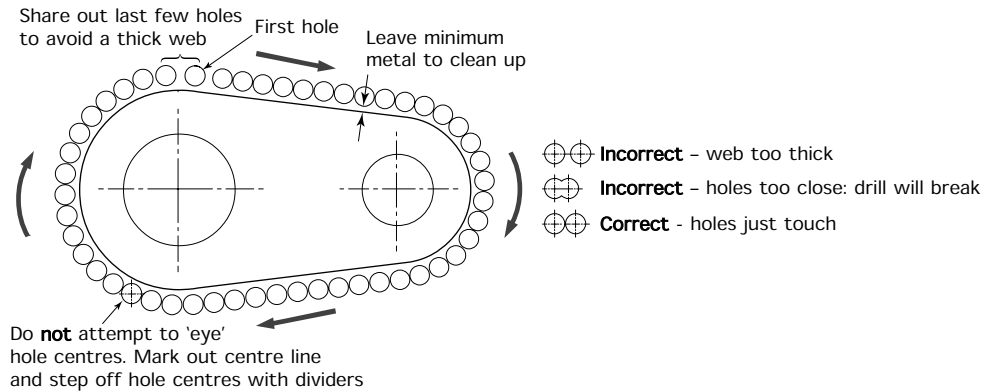


Figure 8.35 Chain drilling

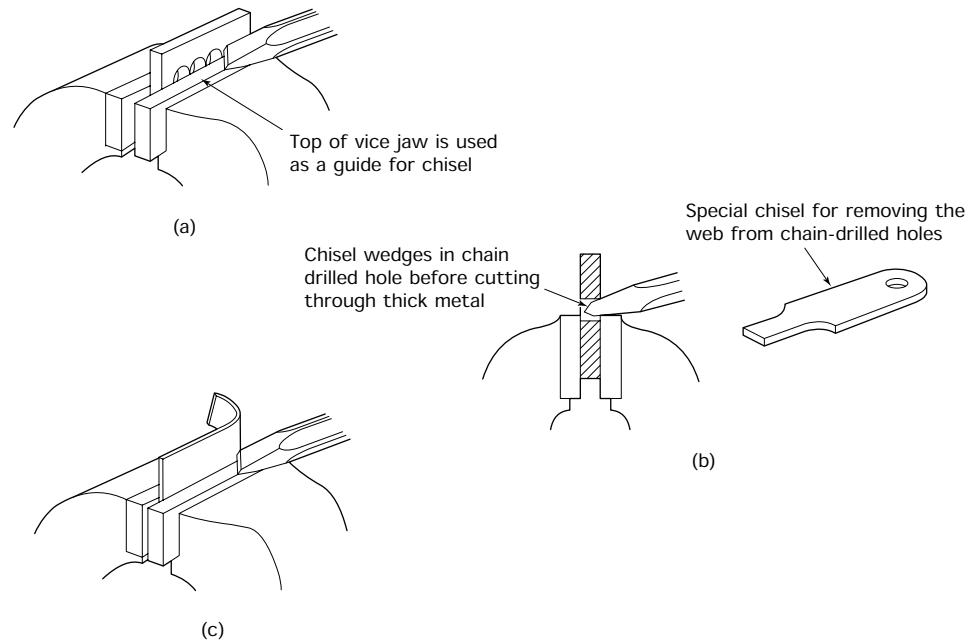


Figure 8.36 (a) Use of the chisel to remove surplus material; (b) problem when chiselling through thick metal – a chisel made from an old piece of HSS power hacksaw blade (right) will not wedge; note the cutting edge is ground off square; not a chisel edge; (c) cutting thin sheet metal using a cold chisel

Figure 8.36(c) shows how sheet metal can be cut using the shearing effect of the chisel used in conjunction with the vice jaws.

The roughed-out link is now ready for finishing by filing away the rough edges left by sawing or chain drilling and chiselling. Until you are more practised, filing the sides flat and straight can best be achieved by

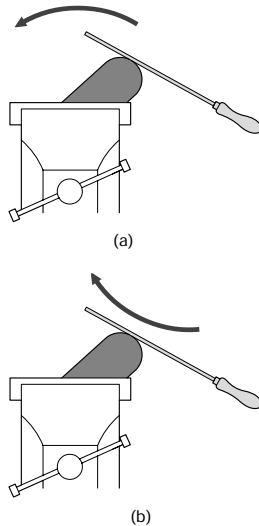


Figure 8.38 *Filing: generation of a curve: (a) incorrect – filing up and over a radius requires an unnatural arm action; this results in a untrue curve; (b) correct – filing in this direction gives a natural arm action leading to a true curve*

8.17 Checking the link

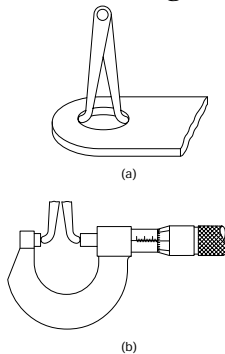


Figure 8.39 *Link: checking the hole diameters: (a) inside calipers are set to the hole diameter; (b) taking care not to disturb the calipers, they are checked with a micrometer to determine the diameter of the hole*

using a piece of old hard-back hacksaw blade as a guide as shown in Fig. 8.37.

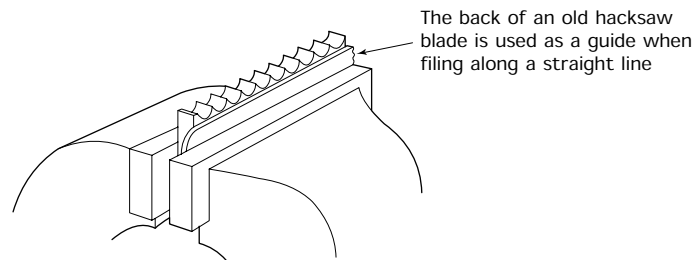


Figure 8.37 *Filing to a straight line*

Some difficulty is often encountered when filing radii. Many beginners try to file over the radius as shown in Fig. 8.38(a). This produces an unnatural arm action and a poor result. The correct technique for filing radii is shown in Fig. 8.38(b). Finally the component should be deburred; sharp edges removed and checked for size. After which, it can be greased up to prevent it corroding and stored until required.

The link we have just made must now be checked. This is done in three stages.

- Hole diameters.
- Hole centres.
- Profile.

Hole diameters can be checked using plug gauges or standard workshop measuring equipment. For example, Fig. 8.39 shows the use of inside calipers and a micrometer. For holes of this size it might be better to use a vernier caliper since the pressure of the micrometer anvils may change the setting of the inside caliper. Great care would need to be taken.

There are several possibilities for measuring the hole centres and two alternatives are shown in Fig. 8.40. If dowels are not available, pieces of silver steel of the correct diameter would be suitable for the accuracy of this component. Finally the profile is checked as shown in Fig. 8.41 and marked with the inspector's stamp.

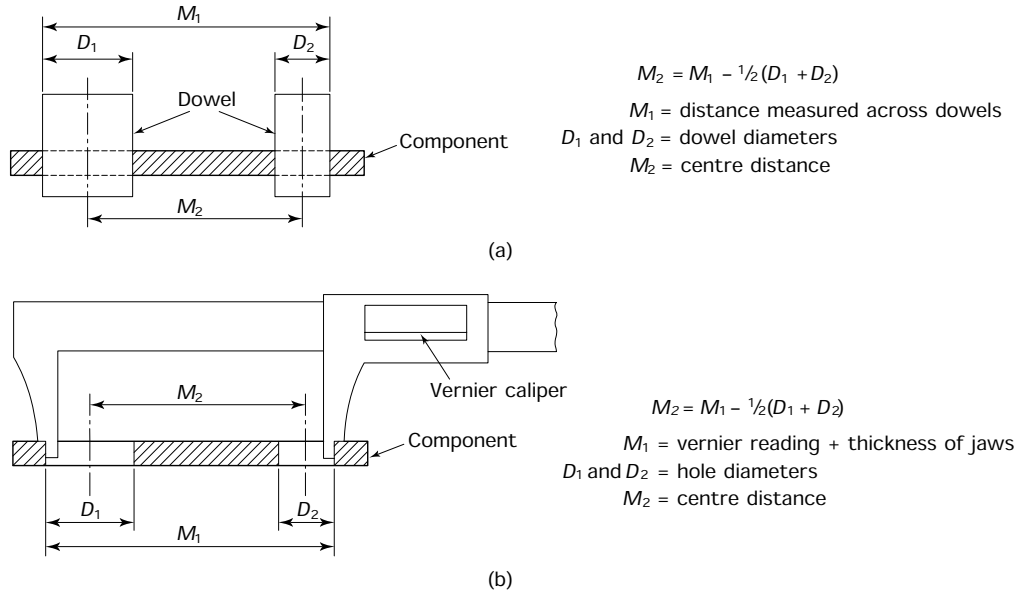


Figure 8.40 Link: checking hole centres: (a) checking across dowels; (b) checking with a vernier caliper – always check to outside of holes to obtain line contact

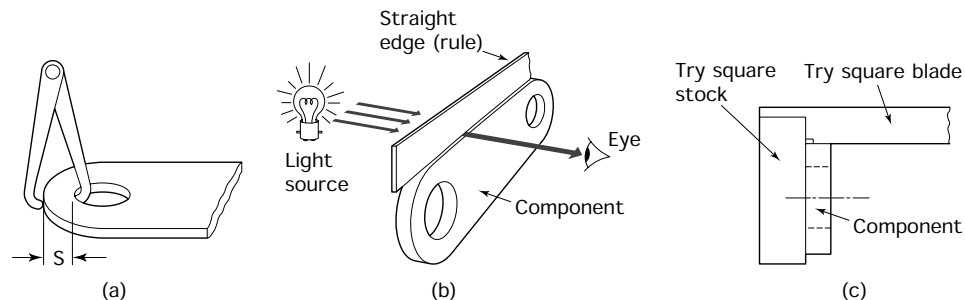


Figure 8.41 Link: checking profile: checking end radii – knowing the hole diameters, the end radii can be checked with outside calipers using the formula $S = R - \frac{1}{2}D$, where $S =$ caliper setting, $R =$ end radius and $D =$ hole diameter; (b) checking straight lines – light will be visible between straight edge and component where any hollows exist in the profile of the component; (c) checking edges for perpendicularity (also check against light source as in (b))

Exercises 8.1 *Selecting suitable hand tools*

- (a) Indicate whether the following statements are TRUE or FALSE, giving the reason for your choice.
- (i) Bench fitting, using hand tools, is suitable for the mass production of engineering components.

- (ii) The initial cost of hand tools is very low compared with the cost of machine tools and their cutters.
 - (iii) Components produced by hand fitting will have a poor finish and low accuracy.
 - (iv) Small and delicate components are best machined since they may not be strong enough to withstand the cutting and clamping forces involved when hand fitting.
 - (v) Except for some prototype work, the unit cost of production when using hand tools is high compared with the production costs when machining.
- (b) State FOUR factors that will affect the choice of tools and equipment selected for producing an engineering component by hand. Give examples.
 - (c) List the requirements of a fitter's bench and vice to ensure efficient working conditions.
 - (d)
 - (i) When requisitioning a file from the stores, explain how you would specify a file for a particular job.
 - (ii) Sketch FOUR types of file and describe the purposes for which they would be used.
 - (iii) Explain how you would specify a hacksaw blade and state the factors that would influence your choice.
 - (iv) Sketch two typical cold chisels and describe the purposes for which they would be used.
 - (v) Describe the hazards associated with chipping and the safety precautions that should be taken for this operation.

8.2 *Preparation of hand tools*

- (a) Name the faults you would look for before using the following items of equipment:
 - (i) hammer;
 - (ii) chisel;
 - (iii) file;
 - (iv) spanner;
 - (v) screwdriver.
- (b) Briefly describe the five principal precautions that should be taken when storing and using files to ensure that they are maintained in good condition.
- (c) Briefly explain why spanners should not be extended to provide additional leverage.

8.3 *Principles of material removal*

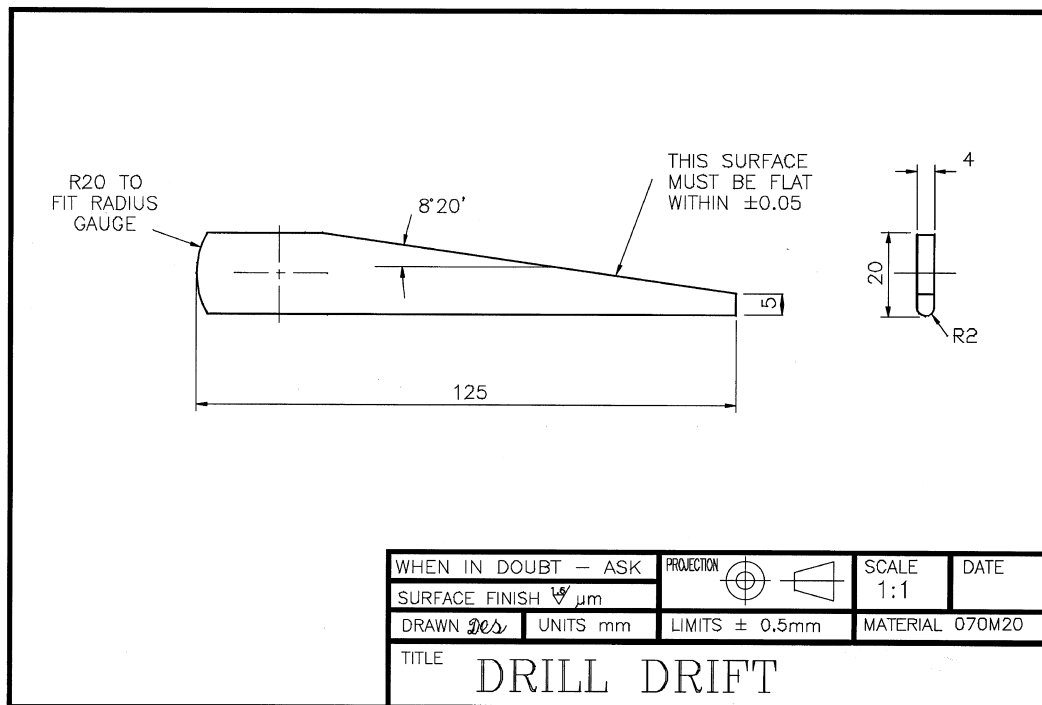
- (a) Name the three fundamental cutting angles of cutting tools.
- (b) Explain briefly how the properties of the workpiece material can influence these angles.
- (c) With the aid of a sketch show how the cutting angles are applied to a cold chisel, a scraper and the teeth of a hacksaw blade.
- (d) Explain why a hacksaw blade has to have a 'set' and, with the aid of a sketch, show how this 'set' can be applied to the teeth of the blade.

8.4 *Screw threads and fastenings*

- (a) (i) Name the type of thread form used on the majority of nuts and bolts.
 (ii) A detail drawing specifies a screw thread as $M12 \times 1.25$. What does this signify?
- (b) With the aid of sketches describe how you would cut an internal thread specified as $M8 \times 1.00$. How would you select a suitable tapping size drill? What size would you use?
- (c) State why a diestock has three screws around the die pocket and explain how these screws are used.
- (d) With the aid of sketches describe two positive and two frictional locking devices for screwed fastenings.

8.5 *Reamers and reaming*

- (a) Indicate whether the following statements are TRUE or FALSE, giving the reason for your choice.
- (i) Hand reamers are used to correct the position of hole centres.
- (ii) Hand reamers are used to improve the accuracy and roundness of drilled holes.
- (iii) Taper reamers are used to correct holes that have become tapered.

**Figure 8.42** *Exercise 8.6(a)*

- (iv) Reamers are only finishing tools and can remove only small amounts of metal compared with drills.
- (b) Briefly describe FOUR precautions that should be taken when reaming to ensure that an accurate hole of good finish is obtained.

8.6 Workshop applications

- (a) Figure 8.42 shows a simple drift for removing taper shank drills. Draw up an operation schedule for its manufacture listing the tools and measuring equipment required.
- (b) The design of the drift is modified to allow a 4 mm diameter hole to be drilled through the wider end so that it can be hung up on a hook when not in use. The hole is to lie on the centre line 8 mm from the wide end.
- Describe how the hole position should be marked out prior to manufacture and list the equipment required.
 - Explain how the modification will affect the operation schedule previously described if the blank is to be held in a machine vice whilst the hole is drilled.
- (c) Figure 8.43 shows the jaws for a toolmaker's clamp.

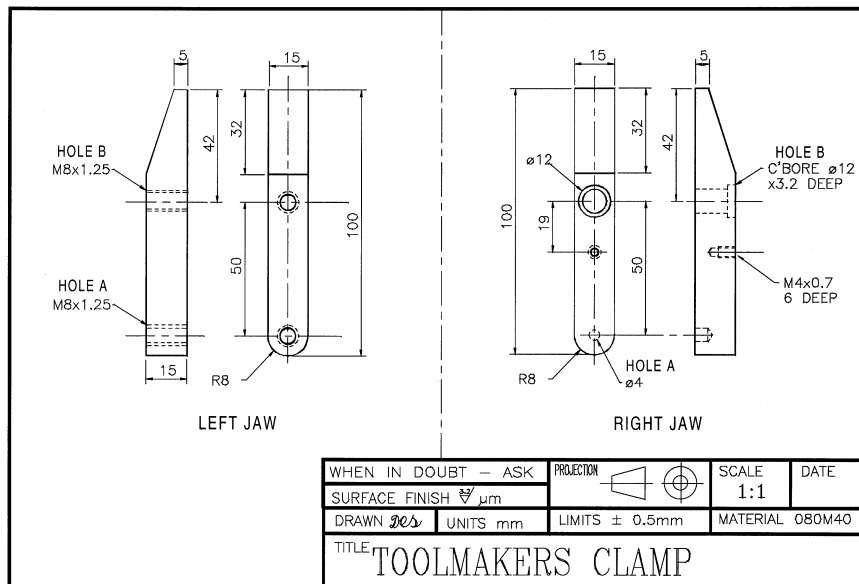


Figure 8.43 Exercise 8.6(c)

- (d) (i) Draw up an operation schedule for manufacturing these jaws. Refer to Chapter 9 for advice on drilling the holes.
- (ii) With reference to Chapter 4, describe how the jaws can be case hardened and suggest a method of keeping the screw threads soft.

9 Drilling techniques and drilling machines

When you have read this chapter you should understand the:

- Application of cutting principles as applied to twist drills.
- Application of cutting angles as applied to twist drills.
- Types of drills that are normally available.
- Application of cutting angles to hand tools.
- Techniques for drilling, reaming, countersinking and counterboring holes in workpieces.
- The basic construction and use of bench and pillar drilling machines.

9.1 The twist drill

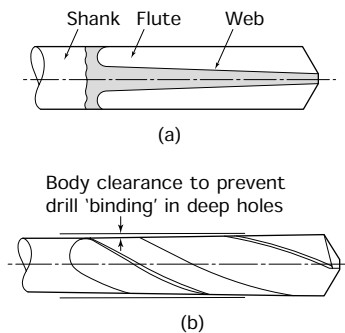


Figure 9.1 *Taper in the twist drill body: (a) web thickness – to give strength to the drill the web thickens towards the shank and the flutes become shallower; point thinning becomes necessary as the drill is ground back; (b) body clearance – the body of the drill is tapered towards the shank to give clearance in the drilled hole*

A twist drill does not produce a precision hole. Its sole purpose is to remove the maximum volume of metal in the minimum period of time. The hole drilled is never smaller than the diameter of the drill, but it is often slightly larger. Dimensional inaccuracy of the hole is brought about by incorrect grinding of the drill point causing the drill to flex. The hole is often out of round, especially when opening up an existing hole with a two flute drill. The finish is often rough and the sides of the hole scored. Thus a twist drill should be used only as a roughing-out tool and, if a hole of accurate size, roundness and good finish is required the hole should be finished by reaming or by single point boring.

The modern twist drill is made from a cylindrical blank by machining two helical grooves into it to form the *flutes*. The flutes run the full length of the body of the drill and have several functions:

- They provide the rake angle.
- They form the cutting edge.
- They provide a passage for any coolant/cutting lubricant.
- They provide a passage for the swarf to leave the hole.

The flutes are not parallel to the axis of the drill but are slightly tapered, becoming shallower towards the shank of the drill as shown in Fig. 9.1(a). This allows the web to be thicker at the shank than at the point of the drill and provides a compromise between the strength and cutting efficiency. A thick web would give maximum strength, but a thin web is required at the point of the drill to give an efficient 'chisel edge' for drilling from the solid. Thus a drill that has been reduced in length by repeated sharpening requires 'point thinning' to compensate for the thickening of the web.

The *lands* are also ground with a slight taper so that the overall diameter of the drill is less at the shank end than at the point as shown in Fig. 9.1(b). This increases the life of the drill and increases its cutting efficiency by preventing the drill from binding in the hole, with a consequent increase in drill life and efficiency. The tapers of the core and the drill body are shown in Fig. 9.1 where they have been exaggerated for clarity.

Figure 9.2 shows a typical twist drill and names its more important features. Although a taper shank drill is shown, the same names apply to parallel shank drills.

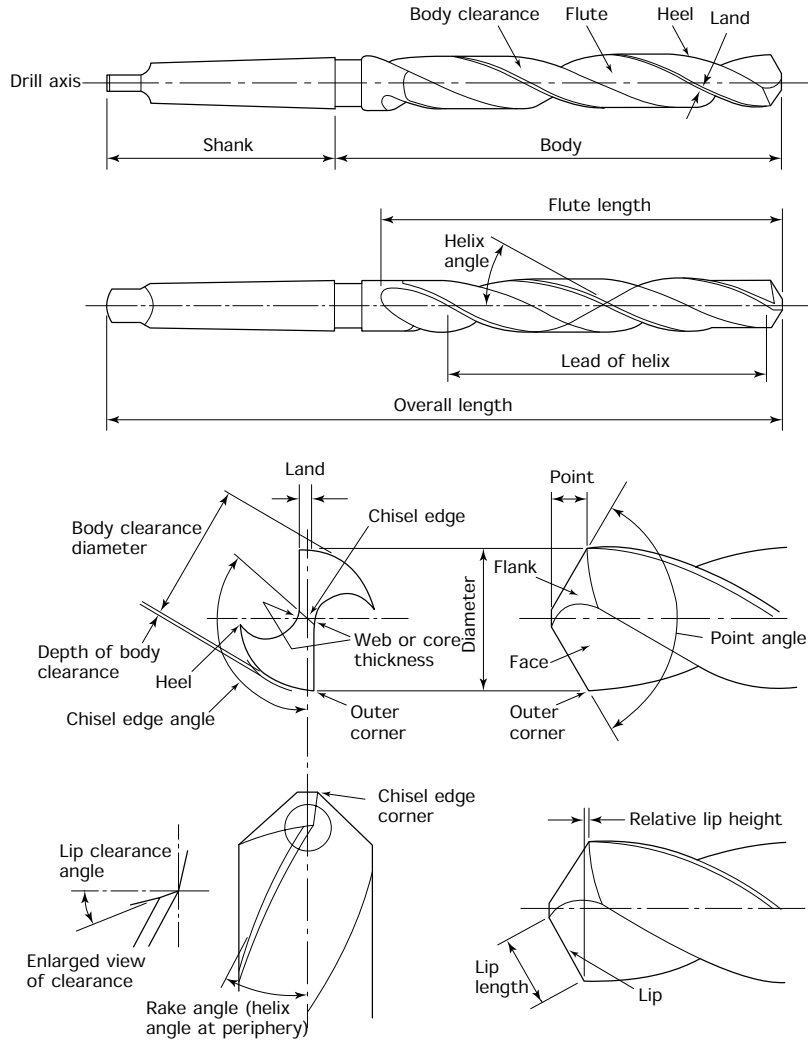


Figure 9.2 Twist drill elements

9.2 Twist drill cutting angles

Like any other cutting tool the twist drill must be compared with the correct cutting angles. Figure 9.3(a) shows how the basic metal cutting wedge is applied to this cutting tool. Because the rake angle is formed by a helical groove (one of the flutes), the rake angle varies from point to point along the lip of the drill as shown in Fig. 9.3(b). You can see that it varies from a positive rake angle at the outer corner of the drill to a negative rake angle near the centre of the drill. The fact that the cutting conditions are poor at the point of the drill does not affect the quality of the hole produced by the outer corner where the cutting conditions are relatively good.

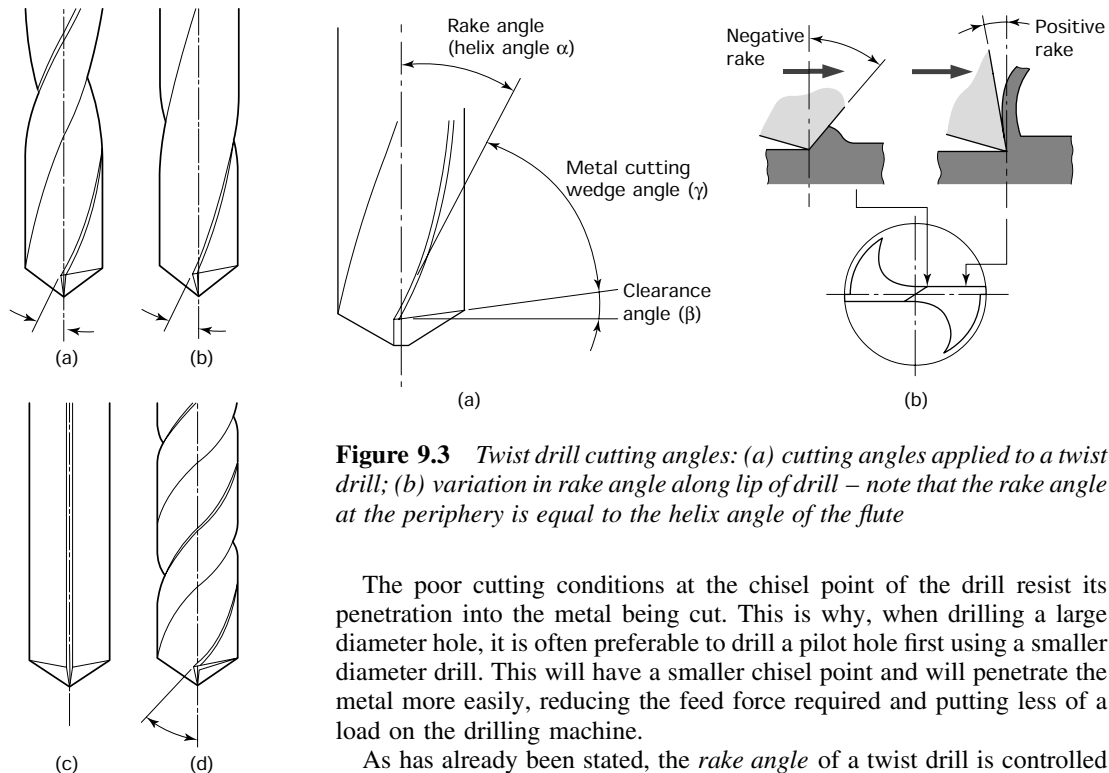


Figure 9.3 Twist drill cutting angles: (a) cutting angles applied to a twist drill; (b) variation in rake angle along lip of drill – note that the rake angle at the periphery is equal to the helix angle of the flute

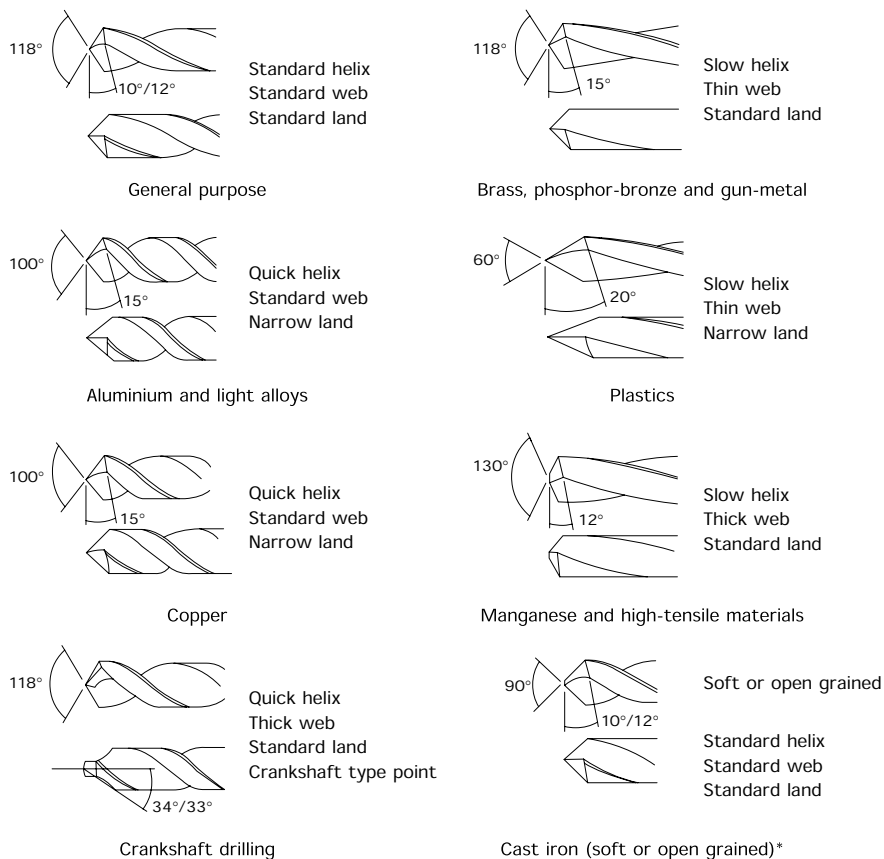
The poor cutting conditions at the chisel point of the drill resist its penetration into the metal being cut. This is why, when drilling a large diameter hole, it is often preferable to drill a pilot hole first using a smaller diameter drill. This will have a smaller chisel point and will penetrate the metal more easily, reducing the feed force required and putting less of a load on the drilling machine.

As has already been stated, the *rake angle* of a twist drill is controlled by the helix angle of the flutes. This is fixed at the time of manufacture and can be only slightly modified during regrinding. Some control of the rake angle is possible by choosing drills with the correct rake angle for the material being cut. Figure 9.4 shows some various types available. These are rarely stock items and are only available to order for production purposes where a quantity of any one size can be ordered.

The *clearance angle* of a twist drill can be adjusted during grinding of the drill point. Insufficient clearance leads to rubbing and overheating of the cutting edge. This, in turn, leads to softening and early drill failure. Excessive clearance, on the other hand, reduces the strength of the cutting edge leading to chipping and early drill failure. Excessive clearance also causes the drill to dig in and ‘chatter’.

Figure 9.4 Helix angles: (a) normal helix angle for drilling low and medium tensile materials; (b) reduced or ‘slow’ helix angle for high tensile materials; (c) straight flute for drilling free-cutting brass – to prevent drill trying to draw in; (d) increased helix angle or ‘quick’ helix for drilling light alloy materials

As well as varying the clearance and rake angle of the drill, its performance can also sometimes be improved by modifying the point angle from the standard 118° for certain materials. Where a large number of drills of the same size are being purchased, the *web* and *land* can also be varied by the manufacturer with advantage. Figure 9.5 shows how the point angle, web and land should be varied for the materials being cut.



* For medium or close grain use a standard drill

For harder grades of alloy cast iron it may be necessary to use a manganese drill

Figure 9.5 Point angles

9.3 Twist drill cutting speeds and feeds

For a drill to give a satisfactory performance it must operate at the correct speed and rate of feed. The conditions upon which the cutting speeds and feed rates given in this chapter are based assume:

- The work is rigidly clamped to the machine table.

- The machine is sufficiently robust and in good condition.
- The work is sufficiently robust to withstand the cutting forces.
- A coolant is used if necessary.
- The drill is correctly selected and ground for the material being cut.

The rates of feed and cutting speeds for twist drills are lower than for most other machining operations. This is because:

- A twist drill is relatively weak compared with other cutting tools such as lathe tools and milling cutters. In a twist drill the cutting forces are resisted only by the slender web. Further, the point of cutting is remote from the point of support (the shank) resulting in a tendency to flex and vibrate.
- In deep holes it is relatively difficult for the drill to eject the chips (swarf).
- It is difficult to keep the cutting edges cool when they are enclosed by the hole. Even when a coolant is used, it is difficult to apply it to the cutting edge. This is because, not only are the flutes obstructed by the chips that are being ejected, but the helix of the flutes tends to ‘pump’ the coolant out of the hole when the drill is rotating.

Table 9.1 lists a range of cutting speeds for jobbing work using standard high-speed steel twist drills under reasonably controlled conditions. Table 9.2 lists the corresponding rates of feed. If the recommended speed and feeds are not available on the drilling machine being used, always select the nearest alternative feed and speed that is *less* than the recommended rate.

TABLE 9.1 *Cutting speeds for high-speed steel (HSS) twist drills*

<i>Material being drilled</i>	<i>Cutting speed (m/min)</i>
Aluminium	70–100
Brass	35–50
Bronze (phosphor)	20–35
Cast iron (grey)	25–40
Copper	35–45
Steel (mild)	30–40
Steel (medium carbon)	20–30
Steel (alloy – high tensile)	5–8
Thermosetting plastic*	20–30

*Low speed due to abrasive properties of the material.

TABLE 9.2 *Feeds for HSS twist drills*

<i>Drill diameter (mm)</i>	<i>Rate of feed (mm/rev)</i>
1.0–2.5	0.040–0.060
2.6–4.5	0.050–0.100
4.6–6.0	0.075–0.150
6.1–9.0	0.100–0.200
9.1–12.0	0.150–0.250
12.1–15.0	0.200–0.300
15.1–18.0	0.230–0.330
18.1–21.0	0.260–0.360
21.1–25.0	0.280–0.380

Example 9.1 *Calculate the spindle speed in rev/min for a high speed steel drill 12 mm diameter, cutting mild steel.*

$$N = \frac{1000S}{\pi d} \quad \text{where: } N = \text{spindle speed in rev/min}$$

$$S = \text{cutting speed in m/min}$$

$$d = \text{drill diameter (mm)}$$

$$\pi = 3.14$$

From Table 9.1, a suitable cutting speed (S) for mild steel is 30 m/min, thus:

$$N = \frac{1000 \times 30}{3.14 \times 12} = \mathbf{796.2 \text{ rev/min}}$$

In practice a spindle speed between 750 and 800 rev/min would be satisfactory with a preference for the lower speed.

Example 9.2 *Calculate the time taken in seconds for the drill in Example 9.1 to penetrate a 15 mm thick steel plate.*

- From Example 9.1, the spindle speed has been calculated as 796 rev/min (to nearest whole number).
- From Table 9.2, it will be seen that a suitable feed for a 12 mm diameter drill is 0.2 mm/rev.

$$t = \frac{60P}{NF}$$

$$= \frac{60 \times 15}{796 \times 0.2}$$

$$= \mathbf{5.7 \text{ seconds}} \quad (\text{to one decimal place})$$

where: t = time in seconds
 P = depth of penetration (mm)
 N = spindle speed (rev/min)
 F = feed (mm/rev)

The calculation of speeds and feeds for drilling is rarely necessary as tables of speeds and feeds for different sizes of drill and material combinations are published in workshop pocketbooks and by drill manufacturers in both book and wall chart form.

9.4 Twist drill failures and faults

Twist drills suffer early failure or produce holes that are dimensionally inaccurate, out of round and of poor finish for the following general reasons:

- Incorrect regrinding of the drill point.
- Selection of incorrect speeds and feeds.
- Abuse and mishandling.

Table 9.3 summarizes the more common causes of twist drill failures and faults and suggests probable causes and remedies. Most cutting tools receive guidance from the machine tool via their shanks or spindles. Unfortunately, twist drills are too flexible to rely on this alone, and derive their guidance from the forces acting on their cutting edges. If these forces are balanced by correct point grinding the drill will cut a true hole of the correct size. However, if these forces are unbalanced due to faulty point grinding, the hole may be oversized, or the drill may wander and follow a curved path, or only one lip may do all the work and be overloaded, or all of these.

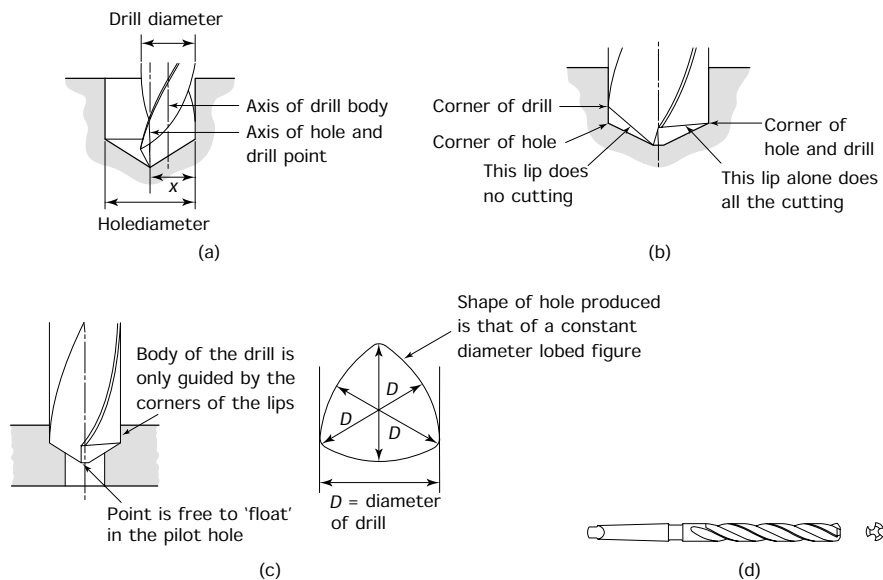


Figure 9.6 Hole faults: (a) effect of unequal lip length – diameter of hole drilled = $2x$, where x = greatest distance from drill point to a corner; oversized hole is caused by drill being ground off centre; (b) unequal angles – only one lip cuts; (c) out of roundness resulting from opening up a pilot hole with a two-flute drill; (d) three-flute core drill will open up an existing hole without loss of roundness

TABLE 9.3 *Twist drill fault-finding chart*

<i>Failure</i>	<i>Probable cause</i>	<i>Remedy</i>
Chipped lips	1. Lip clearance angle too large 2. Feed too great	Regrind point Reduce rate of feed
Damaged corners	1. Cutting speed too high, drill 'blues' at outer corners 2. Coolant insufficient or incorrect 3. Hard spot, scale, or inclusions in material being drilled	Reduce spindle speed Check coolant Inspect material
Broken tang	1. Drill not correctly fitted into spindle so that it slips 2. Drill jams in hole and slips	Ensure shank and spindle are clean and undamaged before inserting Reduce rate of feed
Broken drill	1. Drill is blunt 2. Lip clearance angle too small 3. Drill point incorrectly ground 4. Rate of feed too great 5. Work insecurely clamped 6. Drill jams in hole due to worn corners 7. Flutes choked with chips when drilling deep holes	Regrind point Reduce rate of feed Re-clamp more securely Regrind point Withdraw drill periodically and clean
Damaged point	1. Do not use a hard-faced hammer when inserting the drill in the spindle 2. When removing the drill from the spindle, do not let it drop on to the hard surface of the machine table	Do not abuse the drill point
Rough hole	1. Drill point is incorrectly ground or blunt 2. Feed is too rapid 3. Coolant incorrect or insufficient	Regrind point correctly Reduce rate of feed Check coolant
Oversize hole	1. Lips of drill are of unequal length 2. Point angle is unequally disposed about drill axis 3. Point thinning is not central 4. Machine spindle is worn and running out of true	Regrind point correctly Recondition the machine
Unequal chips	1. Lips of drill are of unequal length 2. Point angle is unequally disposed about drill axis	Regrind point correctly
Split web (core)	1. Lip clearance angle too small 2. Point thinned too much 3. Feed too great	Regrind point correctly Reduce rate of feed

Figure 9.6(a) shows that, when drilling from the solid, the drill is controlled by the chisel point. If the chisel point is offset – the lips of the drill are of unequal length – the hole may be round but it will be over-size as shown. Figure 9.6(b) shows a drill point where the two lips are

of equal length but the point angle is not symmetrical. In this case the lip with the shallower angle will do all the work and the imbalance in the cutting forces will cause the drill to 'wander' and follow a curved path. Figure 9.6(c) shows a hole that has been opened up using a two flute drill. In this example the point of the drill is floating in the pilot hole and the drill is controlled only by the outer corners of the cutting edge. The diameter of the hole will be correct (the distance between the two corners) but the shape of the hole will be a *constant diameter lobed* figure as shown. This fault can be overcome by using a multi-flute (core) drill as shown in Fig. 9.6(d). This drill usually has three flutes and gets its name from the fact that it is used for opening up cored holes in castings. Since it has more than two corners for guidance it will produce a more truly round hole. Core drills cannot be used for drilling from the solid. They can be used only for opening up previously drilled pilot holes.

9.5 Blind hole drilling

A 'blind' hole is one that stops part way through the workpiece. The difference between drilling a 'through' hole and drilling a 'blind' hole is that, in the latter case, a means must be found of stopping the in-feed of the drill when it has reached the required depth.

Most drilling machines are provided with adjustable stops attached to the quill as shown in Fig. 9.7(a). You can see that the depth stop is engraved with a rule type scale graduated in millimetre or in inch units on its front face. This scale is used as shown in Fig. 9.7(b). Touch the drill onto the work and note the reading on the scale. Then use the scale to set the stop nut and lock nut. Figure 9.7(c) shows how these nuts stop

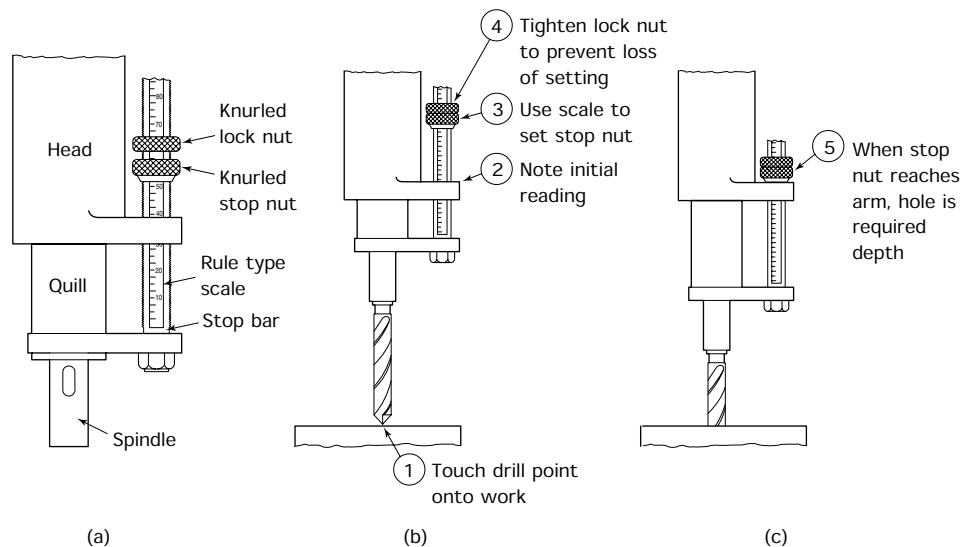


Figure 9.7 Drilling blind holes: (a) depth stop attachment; (b) setting depth stop (setting = initial reading + depth of hole); (c) drill hole to depth; (d) precision depth setting

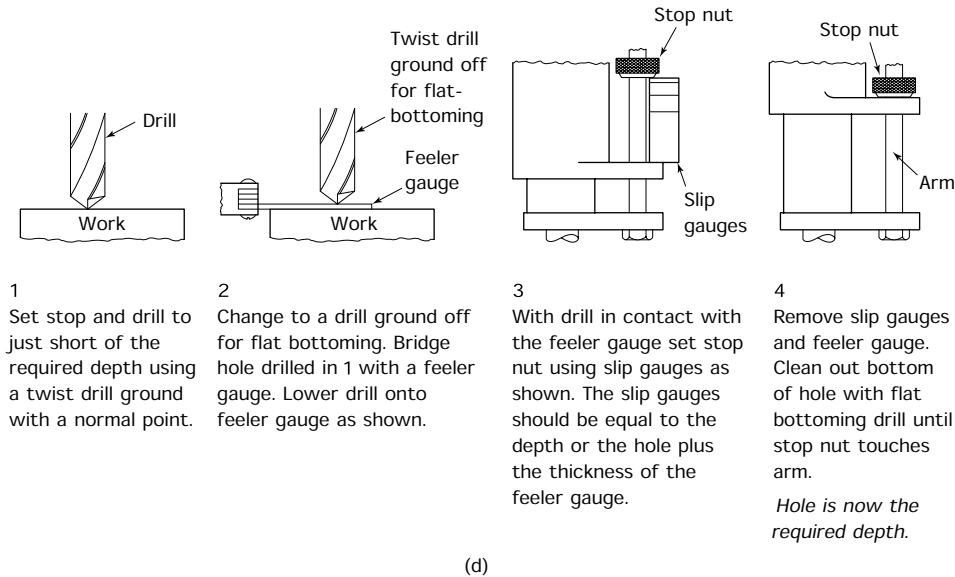


Figure 9.7 (continued)

the in-feed of the drill when the set depth has been reached. For precision depth setting, slip gauges can be used as shown in Fig. 9.7(d).

9.6 Reamers and reaming

Reamers have many more flutes than a core drill and are designed as a finishing tool. They will remove only a very small amount of metal, but will leave an accurately sized, round hole of good finish.

Hand reamers were introduced in Section 8.13. They have a taper lead and a bevel lead. The taper lead provides guidance into the hole, whilst the bevel lead removes any excess metal. Cutting takes place on both the bevel and the taper leads. The parallel flutes have a radial land that prevents cutting but imparts a burnishing action to improve the finish of the hole.

Reamers intended for use in drilling machines and lathes have a rather different cutting action. Figure 9.8 shows three types of machine reamer. They differ from hand reamers in several ways. They have a taper shank to fit the machine spindle and they do not have a taper lead. They have only a bevel lead.

- Reamers that cut only on the bevel lead are said to have a *fluted* cutting action.
- Reamers that also cut on the periphery of the flutes (no radial land) are said to have a *rose* cutting action.
- Hand reamers that cut on the bevel and on the tapered section of the flutes but retain a radial land on the parallel section of the flutes are said to have both a fluted and a rose cutting action.

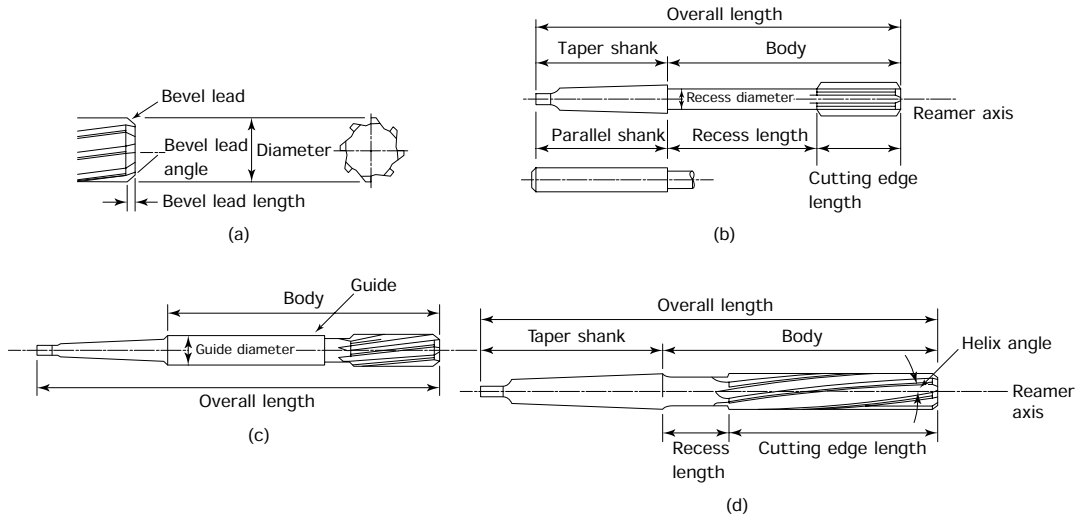


Figure 9.8 Types of machine reamer: (a) entering end of parallel machine reamer (long fluted machine reamer); (b) machine (chucking) reamer with Morse taper or parallel shank; (c) machine jig reamer; (d) long fluted machine reamer with Morse taper shank, right-hand cutting with left-hand helical flutes

Long fluted machine reamers

These cut only on the bevel lead where they have a rose cutting action. The flutes have a radial land and are parallel.

Machine chucking reamers and jig reamers

These may have either a rose cutting action or a fluted cutting action. The recessed diameter of the chucking reamer allows it to operate in deep holes without rubbing and also allows room for the swarf so that no scoring of the previously reamed hole can take place. The guide diameter of the jig reamer allows it to be located by the bush in the jig and ensures that it follows the axis of the previously drilled holes. It is sometimes thought that this can lead to ovality of the finished hole and that it is better to let the reamer float and follow the hole itself. There are no hard and fast rules about this.

Fluted reamers give the best results with steels and similar ductile materials, whereas rose-action reamers are best for cast iron, brass and bronze materials. This latter group of materials tends to spring back and close on the reamer. The peripheral cutting edges of the flutes of a reamer with a rose cutting action remove additional metal as the hole shrinks back on the reamer preventing seizure and broken tooling. Similarly, rose-action reamers are preferable when reaming plastic materials as these also tend to close on the reamer.

Although standard reamers are made for right-hand cutting (clockwise rotation of the reamer), they have flutes that are straight or have a left-hand helix. This serves two purposes:

- To prevent the reamer being drawn into the hole by the screw action of the helix.
- To eject the chips (swarf) ahead of the reamer and prevent them being drawn back up the hole, where they would mark the finished surface of the hole.

The reamer always tries to follow the axis of the existing hole: it cannot correct positional errors. If the original drilled hole is out of position or out of alignment, these errors must be corrected by single point boring (see Section 10.16.3).

9.7 Miscellaneous operations

As well as drilling holes the following operations can also be performed on a drilling machine:

- Trepanning.
- Countersinking.
- Counterboring.
- Spot facing.

9.7.1 Trepanning

Not only is it dangerous to try to cut large holes in sheet metal with a twist drill, but the resulting hole will not be satisfactory. Sheet metal and thin plate have insufficient thickness to guide the drill point and resist the cutting forces. This will result in the drill ‘grabbing’, resulting in a hole that has torn, jagged edges and which is out of round. The metal in which the hole is drilled will also be buckled and twisted round the hole.

One way of overcoming this problem is to use a *trepanning cutter*. Instead of cutting all the metal in the hole into swarf, the trapping cutter merely removes a thin annulus of metal. This leaves a clean hole in the stock and a disc of metal slightly smaller than the hole. The principle of trepanning is shown in Fig. 9.9(a). The simplest type of trepanning cutter is the adjustable ‘tank cutter’ shown in Fig. 9.9(b). It gets its name from the similar type of cutter used by plumbers for cutting holes in sheet metal water tanks for pipe fittings. The central pilot locates the cutter in a previously drilled hole of small diameter. The one-sided, unbalanced cutting action of this device has a number of disadvantages, and the *hole saw* shown in Fig. 9.9(c) is to be preferred if a number of holes of the same size are to be cut.

9.7.2 Countersinking

Figure 9.10(a) shows a typical countersink bit. This is called a *rose bit* since it cuts on its bevel edges (see the cutting action of reamers: Section 9.6). Since the bit is conical in form it is self-centring and does not require a pilot to ensure axial alignment.

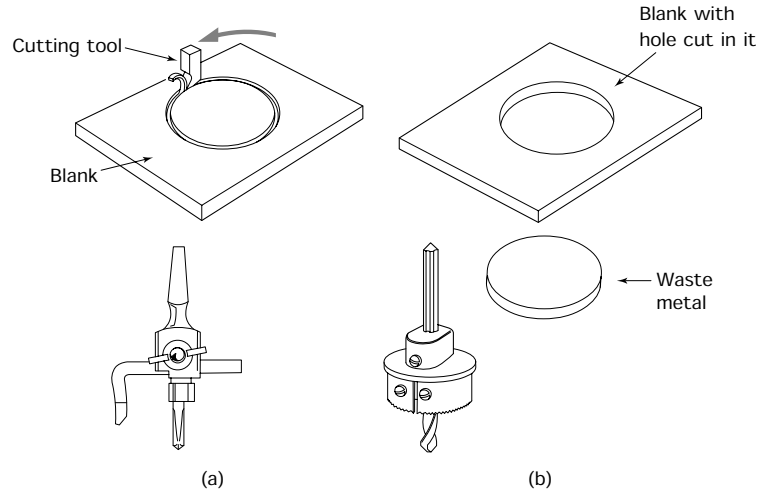


Figure 9.9 Trepanning large holes: (a) tank cutter; (b) hole saw

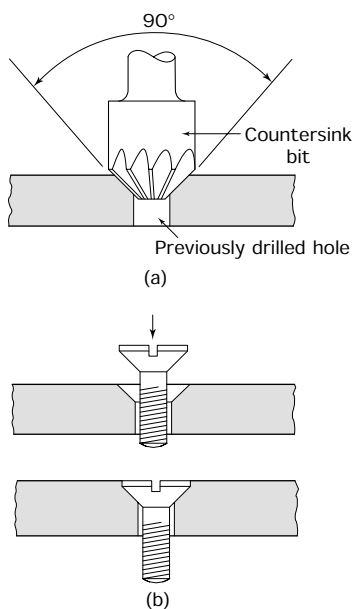


Figure 9.10 Countersinking: (a) cutting a countersink; (b) the countersink allows head of the screw to be recessed

Countersinking is mainly used for providing the recess for counter-sunk screws as shown in Fig. 9.10(b). Less deep countersinking is used to chamfer the sharp edges of previously drilled holes to facilitate the insertion of a bolt, to remove sharp edges and burrs that could lead to cuts, and to reduce the risk of cracking when a component has to be hardened.

9.7.3 Counterboring

Counterboring produces a cylindrical recess for housing the head of a cheese-head screw or a socket-head cap screw flush with the surface of a component. Figure 9.11(a) shows a typical counterbore cutter; Fig. 9.11(b) shows a cap head screw within the recess. The type of cutter used is called a *piloted counterbore* and is similar in appearance to a short, stubby end mill with a pilot. The purpose of the pilot is to ensure that the counterbored hole is concentric with the previously drilled hole. (*Concentric* means that both holes have a *common axis*.)

9.7.4 Spot facing

The purpose of spot facing is to produce a local flat surface as shown in Fig. 9.12(a). This provides a seat for a bolt head or a nut. Bolt heads and nuts must always seat on a surface that is square to the axis of the bolt hole so that the shank of the bolt does not become bent. The type of cutter used is similar to a counterbore cutter but with a larger cutter diameter relative to the diameter of the pilot that fits the previously drilled hole. This is because the spot face has to be slightly larger in diameter than the distance across the corners of the hexagon head of the bolt or nut as shown in Fig. 9.12(b).

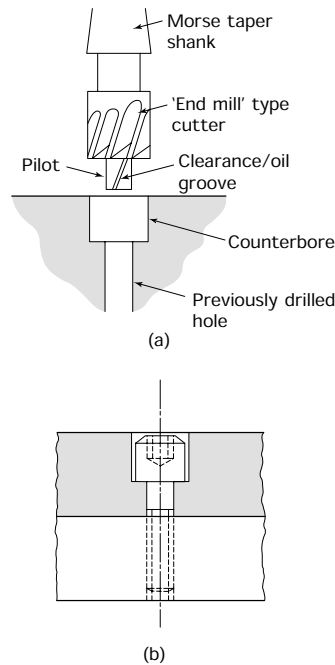


Figure 9.11 Counterboring:
(a) cutting a counterbore;
(b) cap head screw recessed
into a counterbore

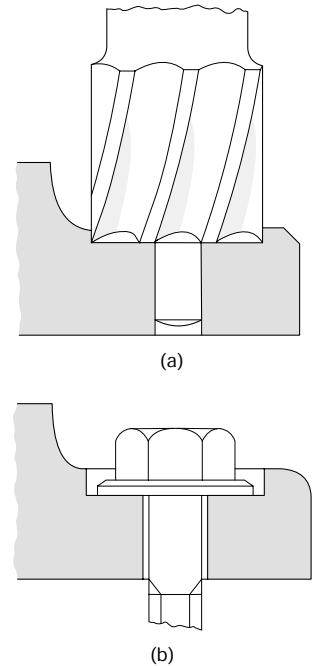


Figure 9.12 Spot facing:
(a) cutting a spot facing on a
casting; (b) spot facing pro-
vides a seating for the bolt
head

9.8 Toolholding

The various cutting tools described previously in this chapter have either a *parallel* (cylindrical) shank or a *taper* shank. Figure 9.13(a) shows a drilling machine spindle suitable for locating and driving taper shank tooling. The tool shanks and the bore of the spindle have matching tapers. These are normally *morse tapers*. The morse taper system provides for tapers that are 'self-securing'. That is, the wedging action of the taper prevents the drill, or other tool, from falling out and it also drives the tool.

Table 9.4 lists the range of drill diameters associated with various morse taper shanks. Figure 9.13(b) shows a typical adapter sleeve for use when the taper of the drill shank is smaller than the taper of the spindle. It also shows an adapter socket for use when the taper shank of the drill is larger than the spindle taper or when converting from one taper system to another. Care must be taken not to overload the machine. The tang on the end of the drill shank is only for removing the drill from the taper in the machine spindle. It is *not* for driving the drill. Figure 9.13(c) shows how a drift is used to remove the drill. *On no account must the drill be overloaded so that it slips in the machine spindle.* This damages the taper shank and the taper bore of the machine spindle. This damage (scoring) would prevent the

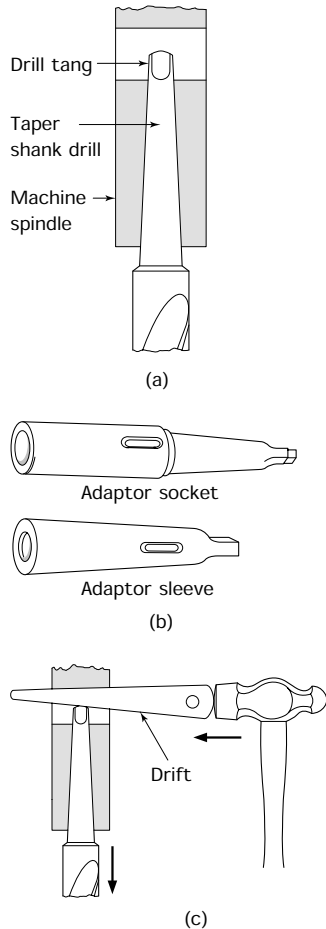


Figure 9.13 Tool holding: taper shank drills

TABLE 9.4 Morse taper shank sizes for twist drills

Morse taper	Drill diameters for normal taper shanks (mm)	Drill diameters for oversize taper shanks (mm)
MT1	3.00–14.00 (inc.)	–
MT2	14.25–22.75 (inc.)	12.00–18.00 (inc.)
MT3	23.00–31.50 (inc.)	18.25–23.00 (inc.)
MT4	32.00–50.50 (inc.)	26.75–31.75 (inc.)
MT5	51.00–76.00 (inc.)	40.50–50.50 (inc.)
MT6	77.00–100.00 (inc.)	64.00–76.00 (inc.)

taper from holding the drill in position and in alignment with the spindle axis. Further, it would no longer be capable of driving the drill.

Figure 9.14(a) shows a drill chuck used for holding and driving tools with a parallel shank together with its chuck key for tightening and loosening the chuck and a chuck arbor. Some small drilling machines have a spindle nose with an external taper to fit directly into the chuck arbor hole. Such machines cannot be used with taper shank drills and tools. For larger drilling machines the chuck arbor is used. It is permanently inserted into the arbor hole of the chuck and is inserted into the spindle of the drilling machine when parallel shank tools are to be used. It can be removed by means of a drift when taper shank tools are to be used.

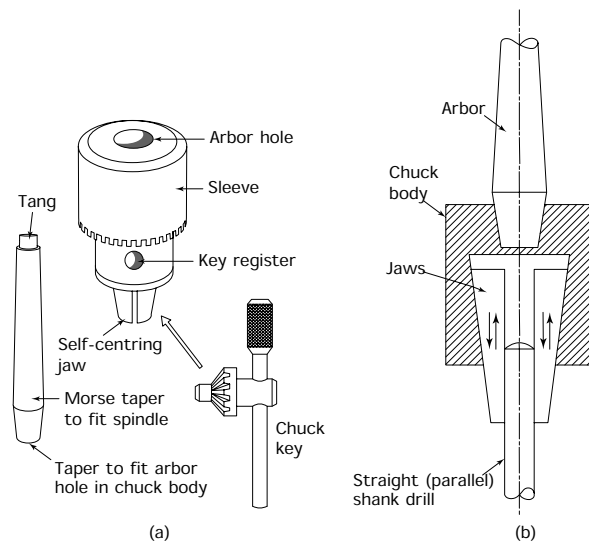


Figure 9.14 The drill chuck: (a) typical drill chuck and accessories; (b) principle of the drill chuck – this drawing shows how a series of concentric tapers are used to maintain axial alignment between the arbor, the chuck and the drill, jaws are shown at 180° for clarity, and the mechanism for moving the jaws is omitted

The chuck itself is self-centring and consists of jaws moving in tapered slots. Therefore, because the system consists of a series of concentric tapers, axial alignment is maintained at all times as shown in Fig. 9.14(b).

9.9 Workholding

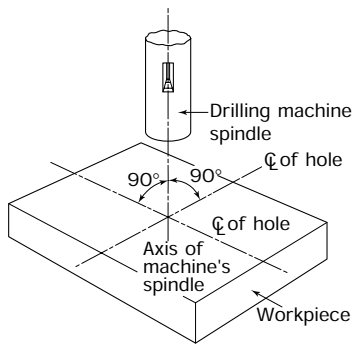


Figure 9.15 Basic drilling alignments

To successfully drill a hole in the correct position four basic conditions must be satisfied.

- The axis of the drill must be concentric with the axis of the drilling machine spindle.
- The drill and spindle must rotate together without slip.
- The workpiece must be located so that the axis of the spindle and drill combination passes through the intersection of the centre lines of the hole to be drilled as shown in Fig. 9.15.
- The workpiece must be restrained so that it is not dragged round by the action of the drill.

9.9.1 Rectangular and similar workpieces

These can be bolted directly to the machine table as shown in Fig. 9.16(a) or they can be held in a vice as shown in Fig. 9.16(b). Note how parallel

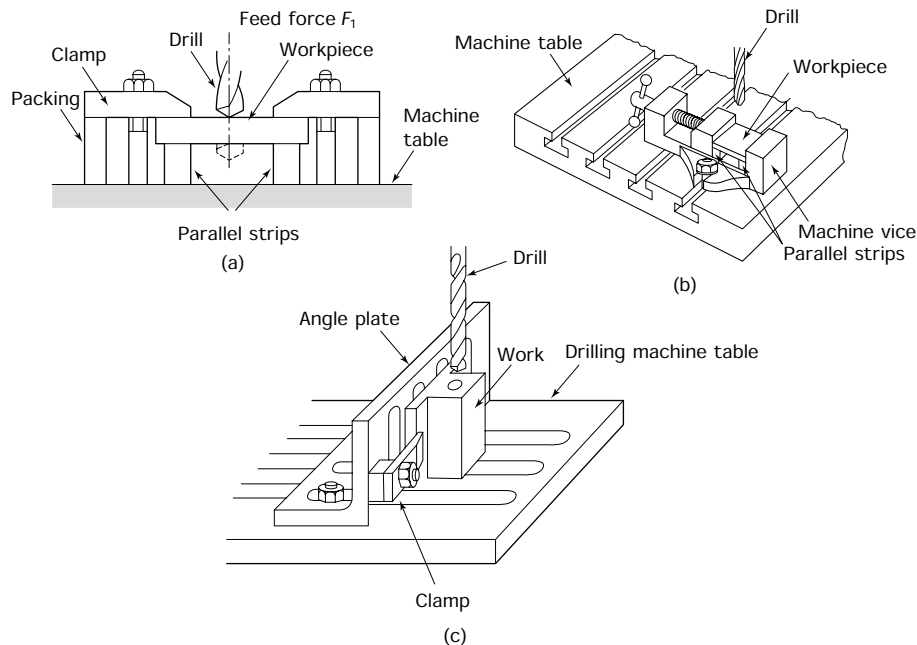


Figure 9.16 Workholding – rectangular workpieces: (a) direct clamping to the machine table; (b) use of a machine vice; (c) use of an angle plate

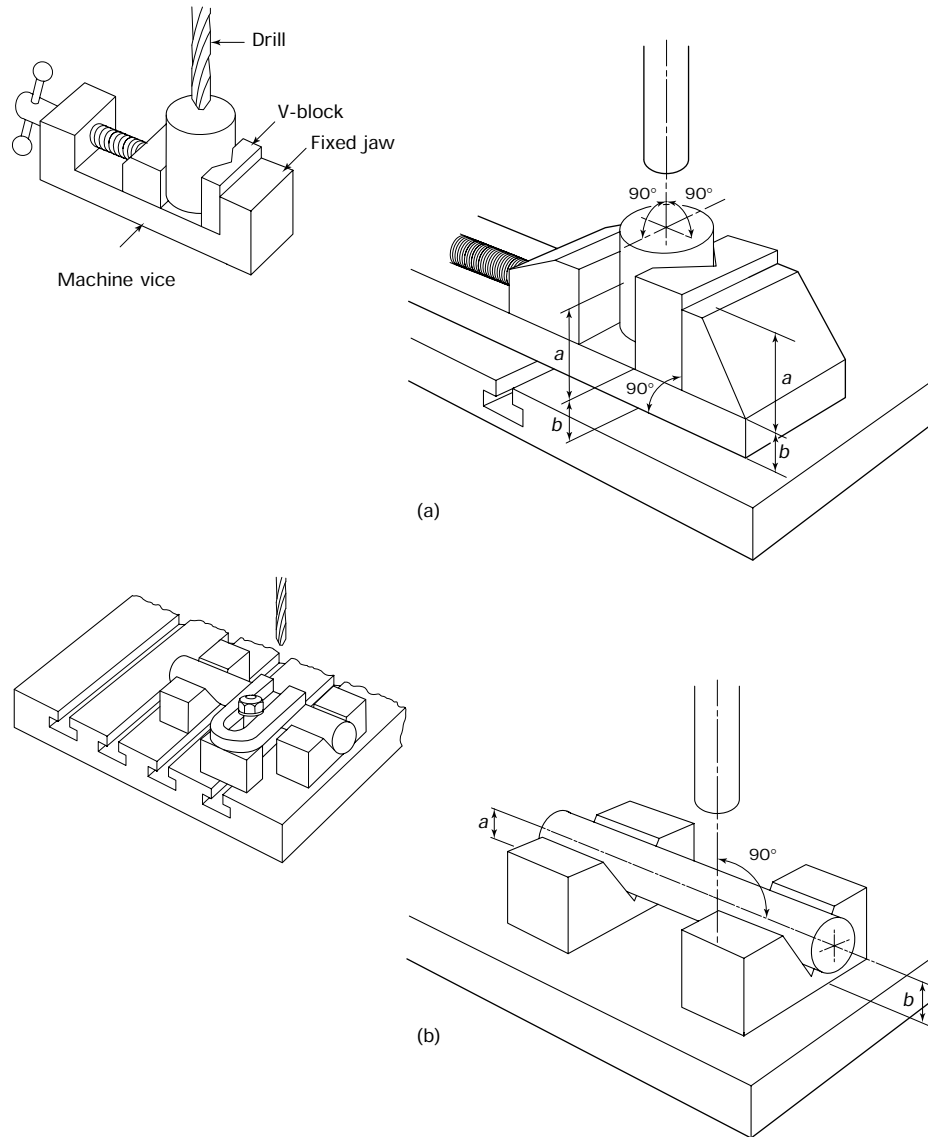


Figure 9.17 Workholding – cylindrical workpieces: (a) holding cylindrical work in a machine vice – to ensure that the spindle axis is parallel to the workpiece axis (i.e. perpendicular to the end face) the following alignments must be checked: **1** – the Vee block must be seated on the vice slide so that its end face is parallel to the slide (a–a); **2** – the vice slide must be parallel to the machine table (b–b); **3** – the fixed jaw must be perpendicular to the machine table; (b) clamping cylindrical work directly to the machine table – to ensure that the axis of the spindle is perpendicular to the axis of the workpiece, the Vee blocks must be a matched pair so that the workpiece axis is parallel to the machine table (a–a)

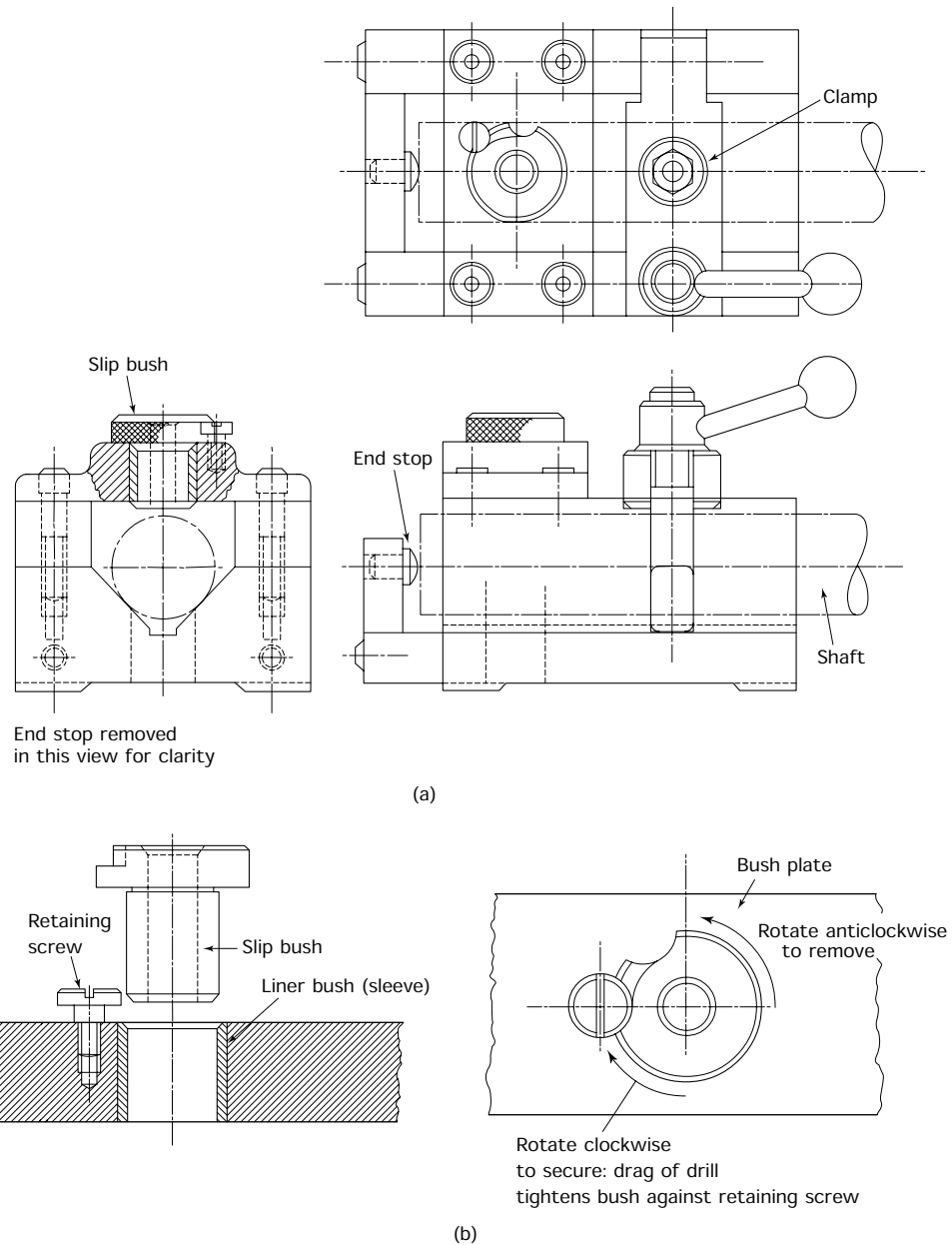


Figure 9.18 Workholding: drilling jig: (a) simple drill for drilling a hole through a shaft at right angles to the axis of the shaft; (b) removable bush and liner sleeve

packing strips are used to support the work so as to prevent the drill from damaging the machine table or the vice as the drill breaks through the underside of the workpiece. Sometimes an angle plate is used when the hole is to be drilled parallel to the datum surface of the work as shown in Fig. 9.16(c).

9.9.2 Cylindrical workpieces

Cylindrical workpieces are more difficult to hold since only a line contact exists between a cylindrical surface and a flat surface. It is advisable to insert a Vee block between a cylindrical component and the fixed jaw of a machine vice to provide a three-point location as shown in Fig. 9.17(a). When the cylindrical component is to be mounted in a horizontal position as shown in Fig. 9.17(b) two vee blocks should be used as shown. Vee blocks are always manufactured in matched pairs for situations such as this and they should always be kept as matched pairs.

9.9.3 Drill jigs

These are used where a number of identical components are to be drilled. The jig is bolted or clamped to the machine table so that it locates and restrains every component that is put into it in exactly the same position relative to the axis of the machine spindle. Thus all the components will have their holes in exactly the same position.

The jig also has a drill bush (or bushes if there is more than one hole) to guide the drill so that it does not wander when the hole is being started. Remember that for this sort of work there is no centre punch mark to guide the drill point. The use of jigs eliminates the expensive process of marking out the components individually. Figure 9.18(a) shows a simple drill jig and names its more important parts. Figure 9.18(b) shows details of the removable bush and its liner sleeve. The bush is inserted in the liner sleeve whilst the hole is drilled in the workpiece. The bush is then removed whilst the hole is reamed at the same setting of the workpiece. This allows the reamer to follow the axis of the previously drilled hole. Also the reamer is larger than the drill and would not pass through the drill bush. Sometimes two different size bushes are used: one for drilling a pilot hole and one for drilling out the hole to the finished size.

9.10 The basic alignments of drilling machines

Let's now refer back to Fig. 9.16, which shows the basic alignments of the spindle axis and the workpiece and see how this is achieved.

- The geometry of a drilling machine must ensure that these basic alignments are achieved.
- The machine must be robust enough to maintain these alignments when subjected to the cutting forces resulting from drilling operations.
- The machine must be robust enough to maintain these alignments when subjected to the load of the workpiece on the machine table.

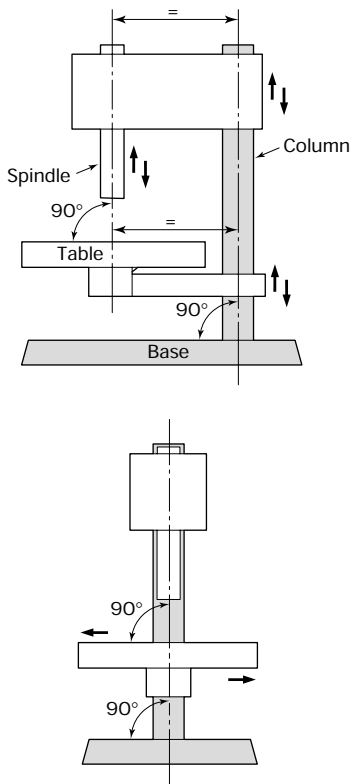


Figure 9.19 The drilling machine: basic alignments

The *spindle* of the drilling machine locates and rotates the drill. It is itself located in precision bearings in a *sleeve* that can move in the body of the drilling machine. The sleeve complete with its spindle is called the *quill*, which can move up or down, without losing its axial alignment. This enables the drill to be fed into the workpiece which is supported on the machine table.

The following basic requirements build up into the skeleton of a drilling machine as shown in Fig. 9.19. This figure also shows the geometrical alignments and movements to be described.

- The spindle axis is perpendicular to the surface of the worktable.
- The worktable is adjustable up and down the column to allow for work of different thicknesses and drills of different lengths. It must also be possible to swing the table from side to side on the column to allow for positioning the work.
- The head of the machine can itself be moved up or down the column to provide further height adjustment.
- After making any of the above movements there must be provision for locking the machine elements in position so that the settings will not move whilst drilling is taking place.
- The column is perpendicular to the base.
- The spindle and sleeve (quill) can move up or down to provide in-feed for the drill when cutting, and allow the drill to be withdrawn from the hole when cutting is finished.
- The axes of the column and the spindle are parallel to each other to maintain the alignments as these movements take place.

9.11 The bench (sensitive) drilling machine

This simplest type of drilling machine is the bench drilling machine as shown in Fig. 9.20(a). It is capable of accepting drills up to 12.5 mm (0.5 inch) diameter. Generally these machines have the chuck mounted directly onto the spindle nose taper. However, some have a spindle with a taper bore to accept either a drill chuck or taper shank tooling in the smaller sizes. Variation in spindle speed is achieved by altering the belt position on the stepped pulleys.

Safety. The machine must be stopped and the electrical supply isolated before removing the guard and changing the belt position.

For normal drilling the spindle axis must be perpendicular to the working surface of the worktable. However, if the hole is to be drilled at an

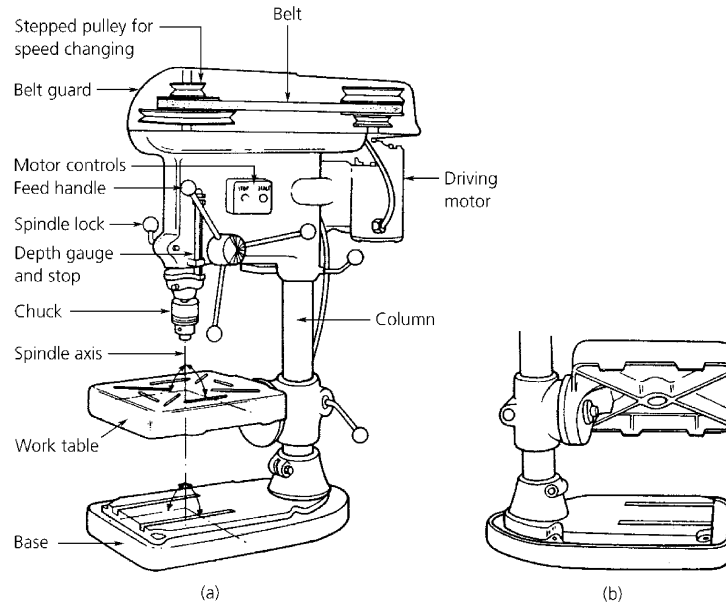


Figure 9.20 (a) Bench drilling machine; (b) table tilted

angle to the workpiece, the table can be tilted as shown in Fig. 9.20(b). Always leave the table horizontal for the next user.

The feed is operated by hand through a rack and pinion mechanism. This type of feed enables the operator to ‘feel’ the progress of the drill through the material being cut so that the operator can adjust the feed rate to suit the cutting conditions. It is from this close control that the operator has over the feed of the drill, that this type of drilling machine gets its name of a *sensitive drilling machine*. Some sensitive drilling machines have an elongated column so that they can be floor standing instead of bench mounted. Otherwise they are essentially the same machine.

9.12 The pillar drilling machine

Figure 9.21(a) shows a typical pillar drilling machine. It can be seen that it is an enlarged and more powerful version of the machine just described. It is floor mounted and much more ruggedly constructed. The spindle is driven by a more powerful motor and speed changing is accomplished through a gearbox instead of belt changing. Sensitive rack and pinion feed is provided for setting up and starting the drill. Power feed is provided for the actual drilling operation. The feed rate can also be changed through an auxiliary gearbox. The spindle is always bored with a morse taper to accept taper shank tooling as well as a drill chuck.

Figure 9.21(b) shows that the circular worktable can be rotated as well as swung about the column of the machine. This allows work clamped to any part of the machine table to be brought under the drill by a combination of swing and rotation. This enables all the holes to be drilled

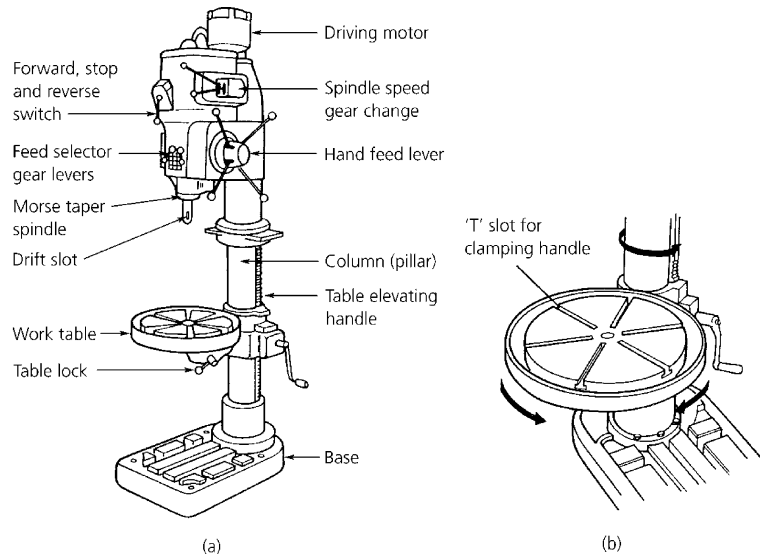


Figure 9.21 (a) Pillar drilling machine; (b) circular worktable

in a component without having to unclamp it and reposition it on the worktable. Holes up to 50 mm diameter can be drilled from the solid on this type of machine.

Exercises 9.1 *Cutting principles and cutting angles as applied to twist drills*

- (a) Indicate whether the following statements are TRUE or FALSE giving the reason for your choice.
- (i) The drilled hole may be larger than the nominal diameter of a twist drill but never smaller.
 - (ii) A twist drill is a single-point cutting tool.
 - (iii) A twist drill provides a hole that is accurate in size and roundness with a good finish.
 - (iv) The web of a twist drill tapers in thickness, increasing towards the shank.
 - (v) The diameter of a twist drill decreases slightly towards the shank.
- (b)
- (i) State the purposes of the flutes of a twist drill.
 - (ii) Sketch a 'D' bit, and briefly describe the advantages and limitations of such a drill and state when it would be used in preference to a twist drill. You will have to research this for yourself.
- (c)
- (i) With the aid of a sketch show how the basic cutting angles of rake, clearance and wedge angle can be applied to a twist drill.
 - (ii) Name a material for which you would require a straight flute drill.

- (iii) Name a material for which you would require a drill whose flutes have a 'slow' helix.
- (iv) Name a material for which you would require a drill whose flutes have a 'quick' helix.
- (d) An 8 mm diameter twist drill is to be used at a cutting speed of 40 m/min and a feed rate of 0.15 mm/rev.
 - (i) Calculate the required spindle speed in rev/min.
 - (ii) Calculate the time taken from the point of contact for the drill to penetrate 12 mm into a component.

9.2 *Twist drill failures and faults*

- (a) When drilling a hole, what is indicated by the swarf only being ejected from one flute? Does this matter?
- (b) With the aid of sketches show the probable point errors that could result in a drill cutting oversize.
- (c) What damage to the drill will result from:
 - (i) too high a cutting speed;
 - (ii) too high a feed rate.
- (d) What are the most likely causes of a rough finish to the hole?
- (e) What are the most likely causes of a drill requiring an excessive downward force to make it penetrate into the work?

9.3 *Reamers and reaming*

- (a) The use of hand reamers was introduced in Chapter 8. With the aid of sketches show the essential differences between:
 - (i) a hand reamer;
 - (ii) a long flute machine reamer;
 - (iii) a chucking reamer.
- (b)
 - (i) In what way do the cutting conditions vary for reaming compared with drilling?
 - (ii) Although most reamers are designed for right-hand (clockwise) cutting, they have straight flutes or left-hand helical flutes. Why is this?

9.4 *Miscellaneous drilling operations*

- (a)
 - (i) With the aid of sketches show the differences between countersinking, counterboring and spot facing.
 - (ii) Explain briefly where the above operations are used and why.
- (b) With the aid of sketches show the difference between trepanning and hole sawing. Under what circumstances is hole sawing preferable to trepanning?

9.5 *Tool holding and workholding*

- (a) Describe, with the aid of sketches, the two most common methods of holding drills in drilling machines.
- (b) Describe, with the aid of sketches:
 - (i) TWO methods of holding rectangular work on a drilling machine;
 - (ii) TWO methods of holding cylindrical work on a drilling machine.
- (c) Large work often has to be clamped directly to the drilling machine table. How can the work be positioned under the drill

when using a pillar drill to drill a number of holes, *without* unclamping and resetting the work on the machine table.

9.6 Drilling machines

- A sensitive drilling machine is often bench mounted and is used for drilling holes of 12 mm diameter or less.
 - Explain why it is called a 'sensitive' drilling machine.
 - Explain why it is suitable for drilling small diameter holes.
- Describe how a pillar type milling machine differs from a sensitive drilling machine.
- With the aid of a sketch show how a DTI can be used to check that the worktable of a drilling machine is perpendicular to the axis of the machine spindle.
- Sketch a suitable guard for a sensitive drilling machine.

9.7 Drilling operations

Draw up an operation schedule for manufacturing the depth gauge component shown in Fig. 9.22 as a single prototype. List the equipment required. Note that the 9 mm radii would be produced by drilling and reaming to 18 mm diameter before cutting out. You may assume that the blank has been squared up and marked out in readiness for manufacture.

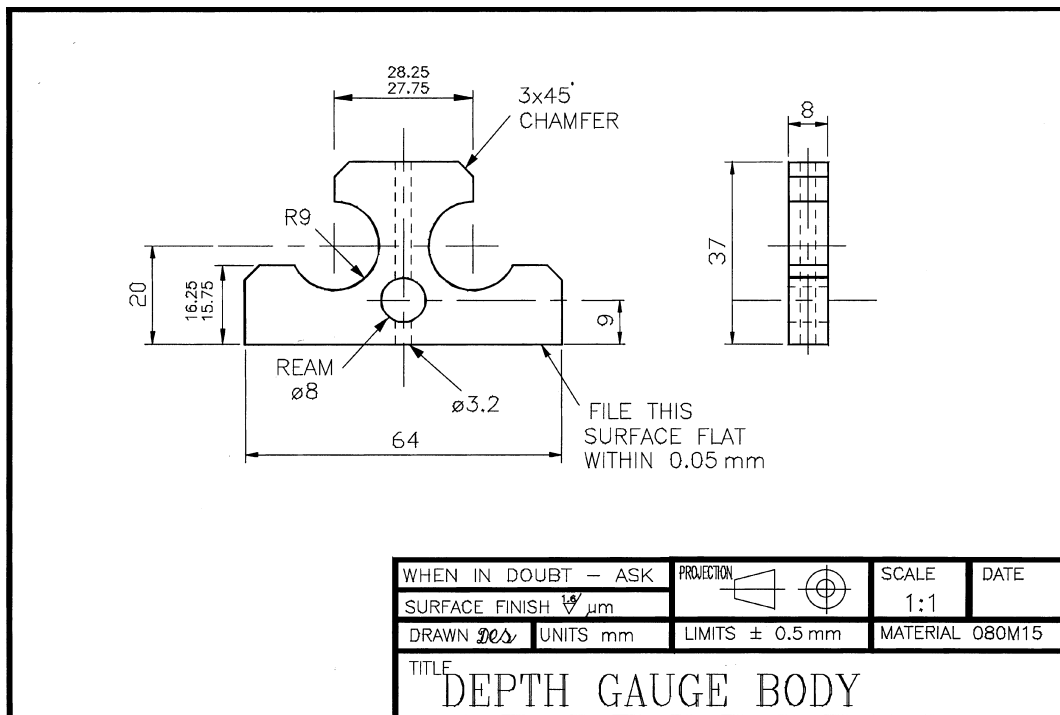


Figure 9.22 Exercise 9.7

10 Centre lathe and turning techniques

When you have read this chapter you should be able to:

- Identify the main features of a centre lathe.
- Identify the main movements and alignments of a centre lathe.
- Identify the surfaces produced by the main movements of a centre lathe.
- Identify the types of spindle nose and chuck mounting for centre lathes and appreciate the advantages and limitations of each system.
- Understand the correct procedures for starting up and closing down the machine.
- Identify and select the type of chucks and chuck mountings normally used.
- Understand and use the methods of setting and holding work in various types of chucks.
- Understand and use the methods of holding work between centres.
- Understand and use the normal methods of tool holding.
- Select cutting tools appropriate to the job in hand.
- Select and use drills and reamers appropriate to the job in hand.
- Calculate the speeds and feeds appropriate to the job in hand and set the machine accordingly.
- Produce screw threads in the centre lathe using taps and dies.
- Produce knurled surfaces.
- Apply the above techniques to typical workpieces.

10.1 The safe use of machine tools

10.1.1 Personal safety

- Do not use a machine unless you have received instruction in its operation.
- Do not use a machine without the permission of your instructor or supervisor.
- Do not lift heavy workpieces or workholding devices onto a machine without assistance or without using the mechanical lifting equipment supplied.

- Do not lean on a machine whilst it is working.
- Do not wear rings on your fingers whilst operating a machine. They may get caught in it.
- Do not place tools and measuring equipment on the headstock of a lathe where they may fall into the revolving chuck.
- Do not attempt to remove swarf with your bare hands – use the rake provided.
- Always wear overalls in good condition and keep them buttoned up so as to prevent any loose clothing becoming caught in any moving machinery. Keep your sleeves rolled up or keep the cuffs closely buttoned at your wrists.
- Always wear safety goggles when cutting is in progress.
- Always wear safety boots or shoes.
- Always adopt a short hairstyle or keep your hair covered in a suitable industrial cap.
- Always use a barrier cream to protect your skin.
- Always report accidents no matter how small.

10.1.2 Machine safety

- Do not attempt to change tools on a lathe whilst the work is revolving.
- Do not remove stops, guards or safety equipment or adjust such devices unless, as part of your training, you do so under the direct supervision of your instructor.
- Do not change the spindle speed whilst the machine is operating as this will cause considerable damage to the gearbox.
- Do not change the direction of rotation of a machine whilst it is running.
- Do not leave your machine unattended whilst it is running.
- Always keep the area around your machine clean and tidy and clear up oil and coolant spills immediately.
- Always clean down your machine when you have finished using it.
- Always make sure you know how to stop a machine.
- Always isolate a machine when changing cutters and workholding devices and loading or unloading work.
- Always stop the machine and isolate it when anything goes wrong.
- Always switch off the machine and isolate it before leaving it at the end of your shift.
- Always check oil levels before starting the machine.
- Always check that workholding devices are correctly mounted and secured before cutting commences.

- Always check that the work is securely restrained in the workholding devices before cutting commences.
- Always make sure the machine is set to rotate in the correct direction before setting it in motion.
- Always make sure any automatic feed facilities are turned off before setting the machine in motion.
- Always clean and return tools and accessories to their storage racks or to the stores immediately after use.
- Always use the correct tools, cutters and workholding devices for the job in hand, never 'make do' with a makeshift set-up.
- Always check that the cutting zone is clear of loose tools, clamps, spanners and measuring equipment before starting the machine.
- Always stop the machine and report any mechanical or electrical defect immediately to your instructor.

Safety is largely a matter of common sense. Never become complacent and take risks to save time. Safety should become a way of life at home and at work. Accidents are always waiting to happen to the inattentive, the careless and the unwary.

This chapter is concerned with centre lathes. There are a number of guards on a lathe; some of these are installed to prevent you coming into contact with the transmission components such as gears and belts. These only have to be removed for maintenance and repairs and, apart from making sure they are in place, you should not have to concern yourself with them. In addition, there are two guards that do concern you.

10.1.3 Chuck guard

This is mounted on the headstock of the lathe and a typical example of a chuck guard is shown in Fig. 10.1. The guard is opened to change the chuck and to load and unload the work. It should be closed before starting the machine and during cutting. Its purposes are as follows:

- To prevent you coming into contact with the rapidly revolving chuck and suffering severe injuries.
- To prevent loose objects placed on the headstock – where they shouldn't be – falling into the revolving chuck and being thrown out with considerable force.
- To prevent the lathe being started up with the chuck key still in place. This used to be a common source of accidents and damage to the machine before chuck guards became commonplace.
- To prevent coolant being thrown out over the floor and the operator when working close to the chuck.

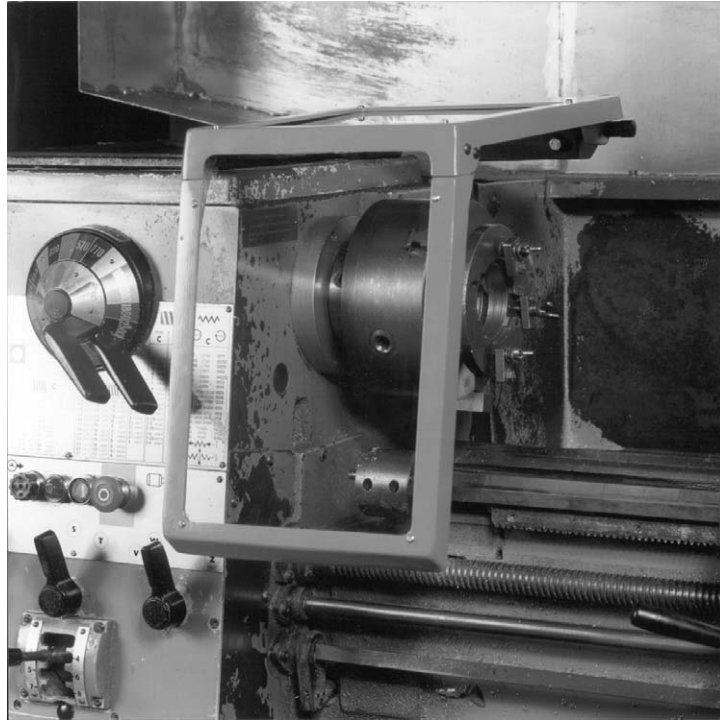


Figure 10.1 *Chuck guard*

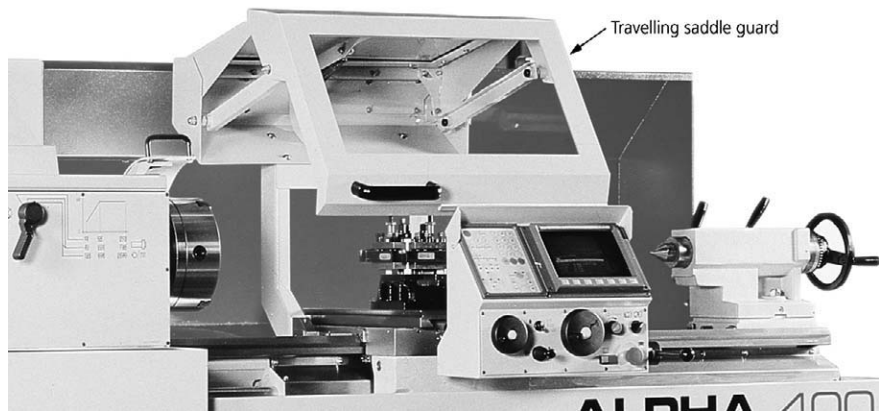


Figure 10.2 *Travelling guard*

10.1.4 Travelling guard

This type of guard is mounted on the saddle as shown in Fig. 10.2. The guard consists of a metal frame fitted with transparent panels so that you can visually monitor the cutting process. The purpose of this guard is to:

- Protect the operator from being sprayed with coolant.
- Protect the operator from chips (swarf) as they fly from the cutting tool. When cutting at high speeds with carbide-tipped tools the chips can be very hot and sharp, particularly if the tool incorporates a chip-breaker.

10.2 Constructional features of the centre lathe

A centre lathe is a machine tool designed and manufactured to produce cylindrical, conical (tapered) and plain (flat) surfaces. It produces these surfaces using a single point tool. It can also be used to cut screw threads. Figure 10.3 shows a typical centre lathe and names the more important features. You can see that it is built up from a number of basic units that have to be accurately aligned during manufacture in order that precision turned components may be produced.

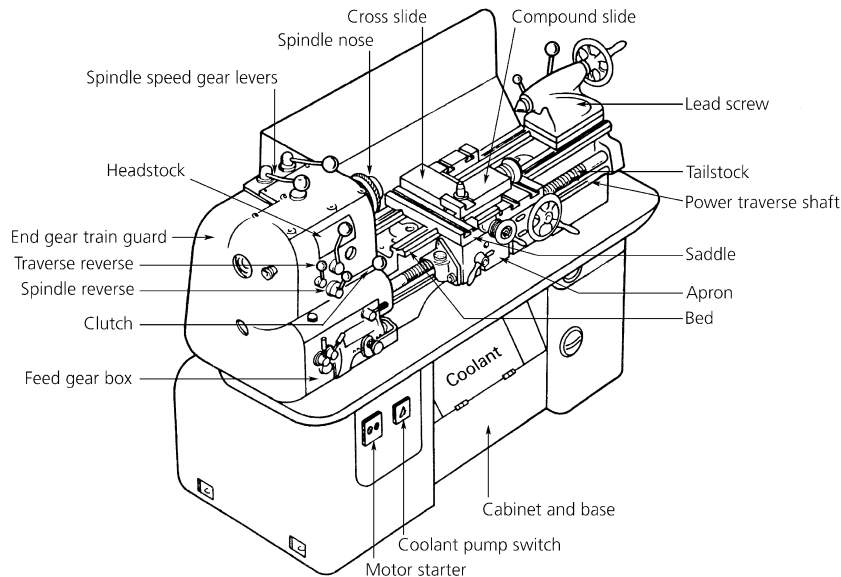


Figure 10.3 Centre lathe

10.2.1 The bed

A typical lathe bed is a strong, bridge-like member, made of high grade cast iron and is heavily ribbed to give it rigidity. Its upper surface carries the main slideways that are sometimes referred to as the 'shears'. Since these slideways locate, directly or indirectly, most of the remaining units, they are responsible for the fundamental alignments of the machine. For this reason the bed slideways must be manufactured to high dimensional and geometrical tolerances. Further, the lathe must be installed with care to avoid distortion of the bed.

10.2.2 The headstock

The headstock, or ‘fast-head’ as it is sometimes called, is a box-like casting supporting the *spindle* and containing a gearbox through which the spindle is driven and its speed adjusted to suit the work being turned.

The spindle is machined from a massive, hollow, alloy-steel forging and its purpose is to carry and drive various workholding devices and the work itself. The spindle is hollow to accept bar stock and its nose is bored internally to a morse taper to accept an adapter sleeve that, in turn, accepts the smaller morse taper of the live centre (turning between centres will be described in Section 10.6). The spindle nose is machined externally to carry various workholding devices such as chucks and faceplates. There are a number of different types of spindle nose in current use and these are described in Section 10.4.

10.2.3 The tailstock

The tailstock, or loose head as it is sometimes called, is located at the opposite end of the bed to the headstock. It can be moved back and forth along its slideways on the bed and can be clamped in any convenient position. It consists of a cast iron body in which is located the *barrel* or *poppet*. The barrel is hollow and is bored with a morse taper. This taper locates the taper shank of the dead centre and it can also locate the taper shanks of tooling such as drill chuck, taper shank drills, die holders, etc. The bore is *coaxial* with the taper bore and nose of the spindle. That is, they have a *common axis* that is parallel to the bed slideways. This is a basic alignment of a lathe. Figure 10.4 shows a section through a typical tailstock. The barrel is given a longitudinal movement within the tailstock body by means of a screw and handwheel. The screw also acts as an ejector for any device inserted in the taper of the barrel. The barrel can be locked in any convenient position within its range of movement. The base of the tailstock has adjusting screws that provide lateral movement. This enables the tailstock to be offset for taper turning (see Section 10.4).

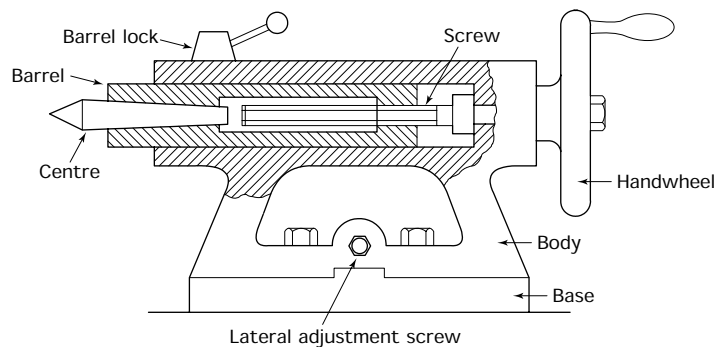


Figure 10.4 *Centre lathe tailstock*

10.2.4 The carriage

A typical lathe carriage is shown in Fig. 10.5. This consists of a *saddle* that lies across the bed of the lathe and an *apron* that hangs down in front of the saddle and carries most of the carriage controls.

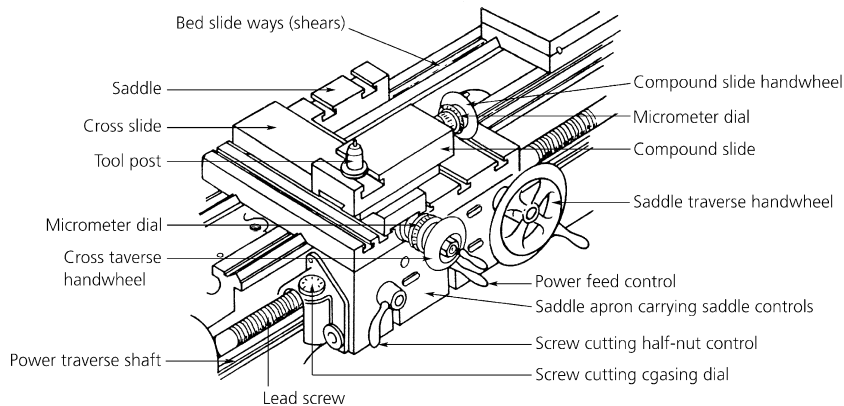


Figure 10.5 Carriage

- The *carriage* moves along the bed of the lathe on the bed slide-ways. Its movement is parallel to the common axis of the headstock spindle and the tailstock barrel. This movement is used when turning cylindrical components.
- The *cross-slide* is situated on top of the saddle and its movement is perpendicular (at right angles) to the common axis of the headstock spindle and tailstock barrel. This movement is used to provide ‘in-feed’ for the cutting tool when turning cylindrical components. It is also used to face across the ends (faces) of components to provide plain (flat) surfaces.
- The *compound slide*, which is also called the *top-slide*, is mounted on top of the cross-slide. It is used to control the ‘in-feed’ of the cutting tool when facing. It also has a swivel base and can be set at an angle when turning short, steep tapers such as chamfers.
- The cross-slide and compound slides are provided with micrometer dials on their screws so that their movements can be accurately controlled (see also Section 10.3).
- The *apron* carries the controls for engaging and disengaging the power traverse for the carriage and the power cross-feed for the cross-slide. It also carries the control for engaging and disengaging the half-nut when screw cutting from the lead screw.

10.2.5 The tool post

The tool post is mounted on top of the compound slide and carries the cutting tool. Figure 10.6 shows the four types most commonly used. The tool post shown in Fig. 10.6(a) is simple and robust but not much used

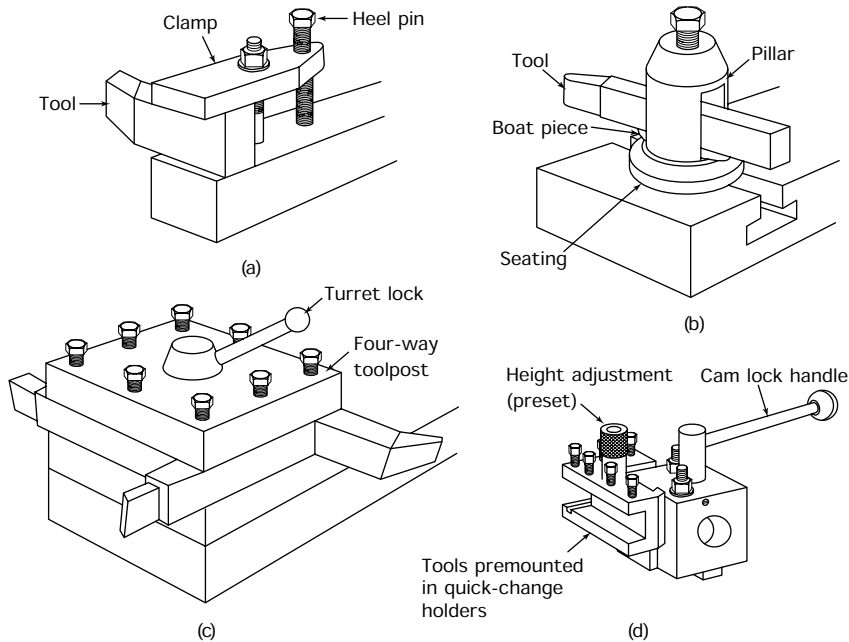


Figure 10.6 Centre lathe toolposts: (a) English (clamp) type toolpost; (b) American (pillar) type toolpost; (c) turret (fourway) type toolpost; (d) quick release type toolpost

nowadays other than on small, low-cost lathes. The height of the tool can be adjusted only by adding or removing packing and shims until the tool is at the correct height. The tool post shown in Fig. 10.6(b) is commonly used on light-duty lathes. The tool height is quickly and easily adjusted by rocking the boat-piece in its spherical seating. Unfortunately this type of tool post lacks rigidity due to the overhang of the tool. Further, tilting the tool to adjust its height alters the effective cutting angles. The four-way turret tool post shown in Fig. 10.6(c) saves time when making a batch of components. All the tools required are mounted in the tool post and each can be swung into position as required by rotating (indexing) the turret. This limits the number of tools that can be used to four. Also the only way to adjust the tool height is by the use of packing. Tools with only relatively small shanks can be held in this type of tool post.

The quick release tool post shown in Fig. 10.6(d) is increasingly used. An unlimited number of tools can be preset in the holders ready for use. Tool height is quickly and easily adjusted by means of a screw. Also the tools can be preset for height in a setting fixture away from the lathe. The tool holder complete with tool is slipped over the dovetail slide of the tool post and locked in position by a lever-operated cam. It is just as easily and quickly removed.

10.2.6 The feed gearbox

It has already been said that the carriage apron has controls for screw cutting from the lead screw and for power traverse for the carriage and

cross-slide. The drive to the lead screw and the traverse shaft is through a variable speed gearbox. This feed gearbox is driven from the spindle of the lathe by an *end-train* of gears as shown in Fig. 10.7. The reason for driving the feed gearbox from the spindle is that once the feed has been set for a particular operation, the tool movement per revolution of the work must remain constant even if the spindle speed is changed. The feed gearbox has three functions.

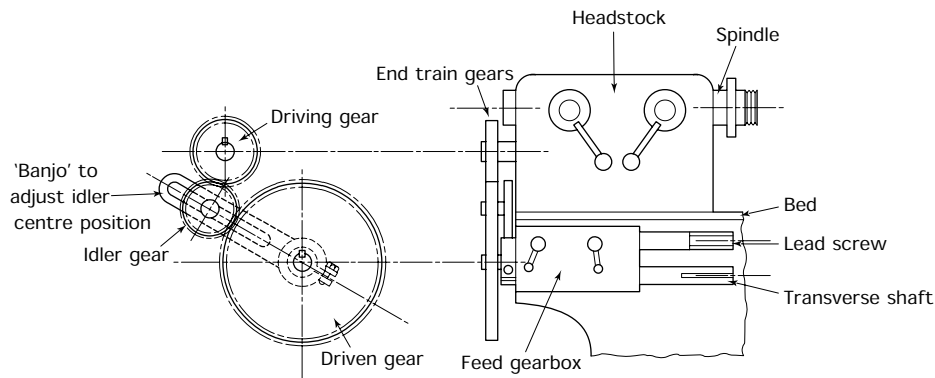


Figure 10.7 Centre lathe end train gears

- To control the speed at which the saddle is driven along the bed of the lathe when cylindrically turning with longitudinal power traverse.
- To control the speed at which the cross-slide moves across the saddle when power cross-traversing (facing).
- To control the speed of the lead screw relative to the rotational speed of the workpiece when screw cutting and thus control the lead of the screw being cut.

10.3 Main movements and alignments

Figure 10.8(a) shows the basic alignment of the headstock, tailstock, spindle and bed slideways. The common spindle and tailstock axis is parallel to the bed slideways in both the vertical and horizontal planes. This is the basic alignment of the lathe and all other alignments are referred to it. The movements of the carriage and the tailstock along the bed and the movement of the tailstock barrel within the tailstock body are parallel to the common axis in both the vertical and horizontal planes. These movements are shown in Fig. 10.8(b). These alignments and movements are fundamental to the accuracy of the machine and must be carefully preserved.

The cross-slide, which is mounted on the carriage, is aligned so that it is perpendicular (90°) to the common spindle and tailstock axis. This is shown in Fig. 10.9(a). The movement of the cross-slide is also at right angles to the common spindle and tailstock axis. Therefore this axis can be used for producing plane surfaces that are perpendicular to the common axis (facing) as shown in Fig. 10.9(b). This slide is also used for

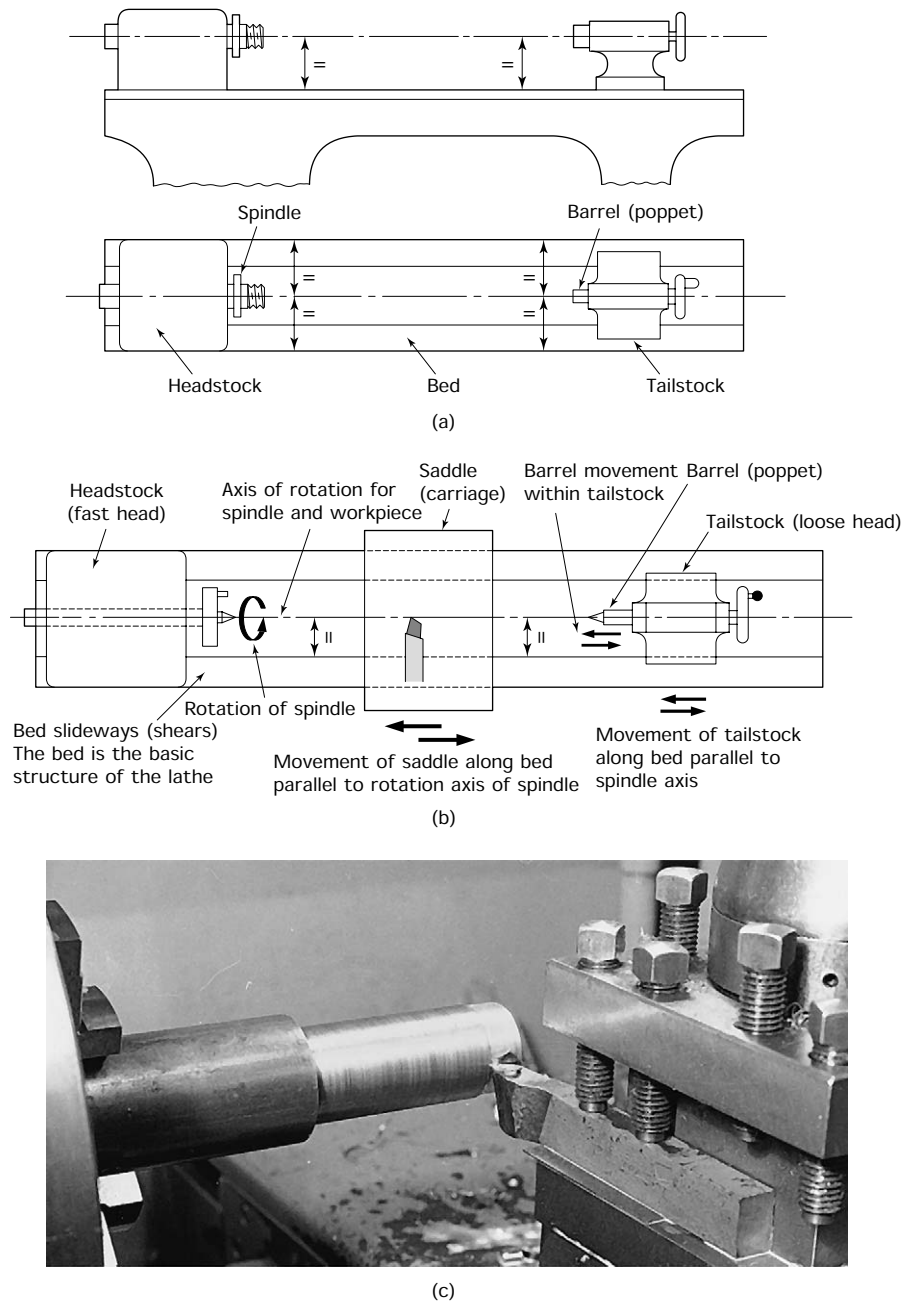


Figure 10.8 Centre lathe: basic alignments: (a) basic alignment; (b) the carriage or saddle provides the basic movement of the cutting tool parallel to the work axis; (c) cylindrical (parallel) turning

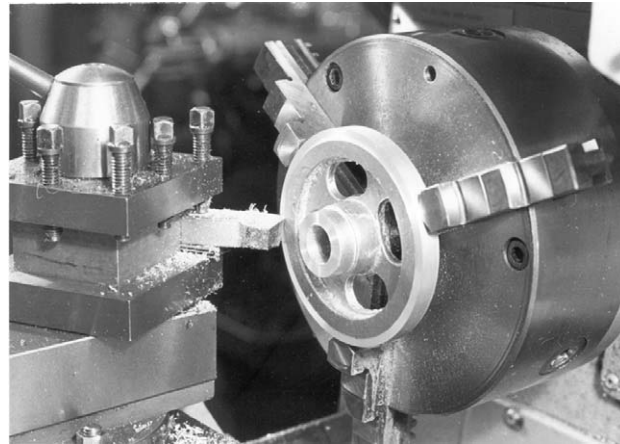
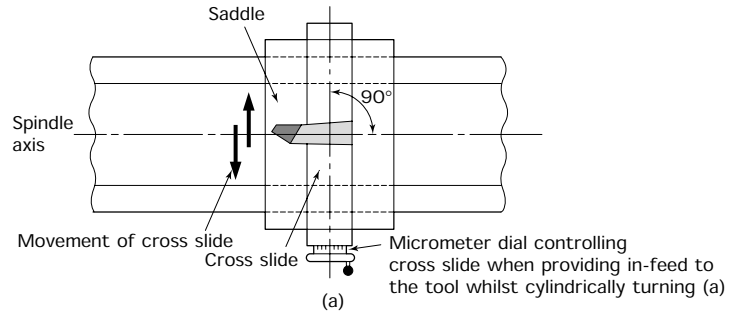


Figure 10.9 *The cross-slide (a), facing (surfacing) (b)*

providing and controlling the in-feed of the cutting tool when turning cylindrical workpieces. For this purpose its traverse screw is fitted with a micrometer dial.

The compound slide (top slide) is located on top of the cross-slide and can be set parallel to the common headstock and tailstock axis. In

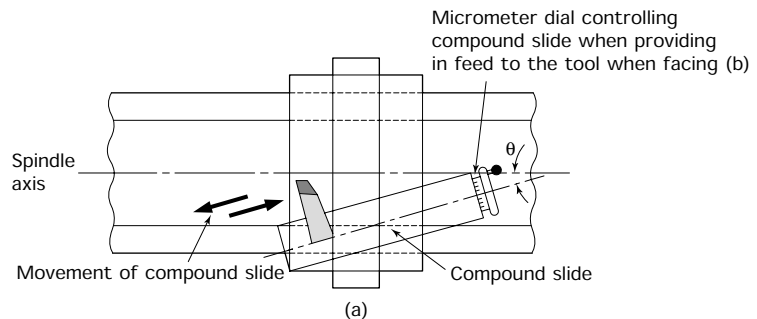
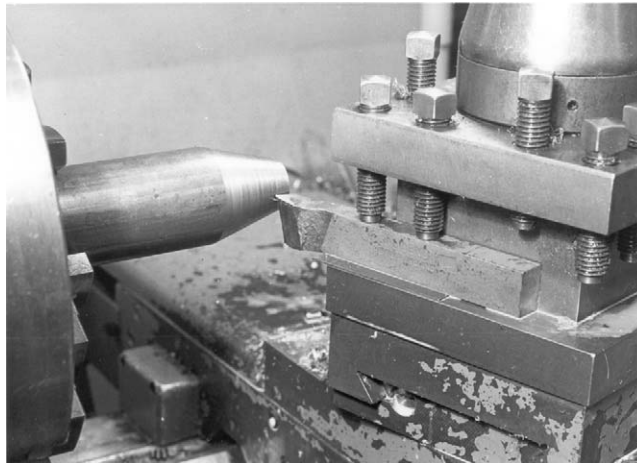


Figure 10.10 *The compound (top) slide (a), taper turning (b)*



(b)

Figure 10.10 (*continued*)

this position it can be used for providing and controlling the in-feed of the cutting tool when facing across plane surfaces. For this purpose its traverse screw is fitted with a micrometer dial.

The compound slide can also be set at an angle to the common axis when short tapers, such as chamfers, are to be produced. The movement of this slide when taper turning is shown in Figs 10.10(a) and 10.10(b).

10.4 Types of spindle nose

Figure 10.11 shows three types of spindle nose in common use. To ensure that the workholding device mounted on the spindle nose runs true, *always* clean the plain or tapered spindle mountings and the corresponding internal registers of the workholding devices carefully before mounting them on the spindle.

10.4.1 Plain nose spindle

The *plain nose spindle*, as shown in Fig. 10.11(a), is the simplest and cheapest to manufacture but is the least effective. There is no way that it can be adjusted to compensate for wear. After heavy cutting the chuck will have tightened on the thread to such an extent as to make removal difficult. Any attempt to stop the lathe quickly using an emergency brake can result in the chuck unscrewing itself and spinning off which is highly dangerous. If the lathe is run in reverse to cut a left-hand thread, again the chuck will tend to unscrew itself. Plain nose spindles are found only on small low-cost lathes nowadays.

10.4.2 The long taper nose spindle

The *long taper nose spindle*, as shown in Fig. 10.11(b), provides a taper location that is much more accurate than the plain nose. Also as wear takes

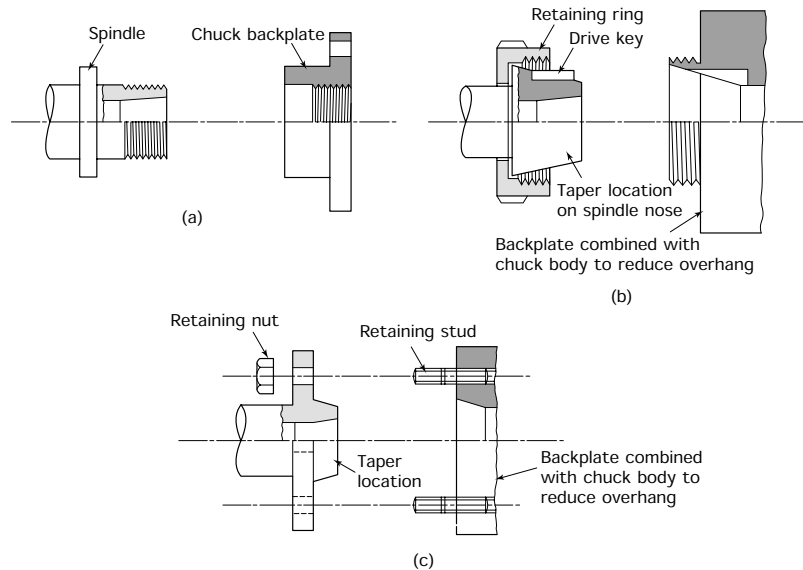


Figure 10.11 Spindle nose mountings: (a) plain nose spindle; (b) long taper nose spindle; (c) short taper nose spindle

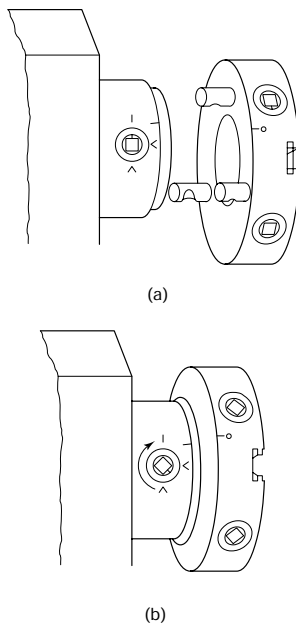


Figure 10.12 Cam lock spindle mounting: (a) locate pegs in holes on spindle nose; (b) turn clockwise to lock chuck

place the chuck or other workholding device simply seats more deeply on the taper and no accuracy of alignment is lost. The drive is positive and via a key and keyway. The chuck or other workholding device is retained on the spindle and pulled tight against the taper nose by a threaded ring. There is no way in which the chuck can spin off the spindle nose or work loose under any cutting conditions.

10.4.3 The short taper nose spindle

The *short taper nose spindle* is used with workholding devices retained by studs and nuts on older machines as shown in Fig. 10.11(c). The short nose taper has the advantage of reducing the overhang of the mounting, resulting in increased rigidity.

10.4.4 The camlock spindle

The *camlock spindle* is shown in Fig. 10.12. It also has a short taper but, in place of the studs and nuts of the previous example, it has a cam locking system that is quicker and easier to use when changing workholding devices. It is the most widely used mounting on modern industrial size lathes. To fit a workholding device to a camlock spindle:

- Clean the tapered spigot and face on the machine spindle.
- Clean the tapered register, face and pins on the back of the chuck.

- Use the square ended key provided to turn the camlock device so that the setting marks line up.
 - Mount the chuck on the spindle, engaging the pins in the holes in the spindle nose flange.
 - Using the key, turn the camlock devices clockwise until they are tight. The setting mark must now be between the two V marks. These are at 90° and 180° to the original setting mark.
 - Repeat for all camlock devices. To remove the workholding device the procedure is reversed.
-

10.5 Starting up and closing down the machine

Before considering the use of the lathe to produce components, it is necessary to understand how to start up and close down the machine in a safe and proper manner.

10.5.1 Starting up

- Check that the isolating switch is in the *off* position.
- Visually inspect to ensure all controls are in the *off* or *neutral* positions, the key has not been left in the chuck, and no tools, measuring instruments, or workpieces have been left lying about on the machine. Check that the machine is clean and free from swarf.
- Fit the appropriate workholding device for the work in hand and ensure it is securely fastened.
- Mount the workpiece in the workholding device securely.
- Select and set an appropriate tool in the tool post and check for centre height.
- With the gearbox in neutral, rotate the work by hand to ensure that it does not foul on the machine or the cutting tool.
- Select the required spindle speed and feed rate.
- Turn on the isolating switch, switch on the coolant pump if it is to be used, switch on the low voltage lighting if it is required. Start the main drive motor.
- Engage the clutch gradually to see that the work rotates safely.
- Commence the cutting operation.

10.5.2 Shutting down

- Stop the machine and turn off the isolating switch.
- Ensure all controls are left in a safe position.
- Remove the work, the cutting tools and the workholding device.

- Return all tools, measuring instruments and other ancillary equipment to the stores or the cabinet at the side of the machine as appropriate.
- Remove swarf from the coolant tray and clean the machine.
- Remove any spilt oil or coolant and swarf from the floor around the machine and leave the floor safe.

Leave the machine as you would wish to find it.

10.6 Workholding devices (centres)

Holding work between centres is the traditional method of workholding from which the centre lathe gets its name. This method of workholding is shown in Fig. 10.13. The *centres* locate the work in line with the common axis, and the work is driven by the *catchplate* on the spindle nose and a *carrier* on the workpiece. The centres are located in morse tapers to ensure concentricity with the bores of the spindle nose and the tailstock barrel.

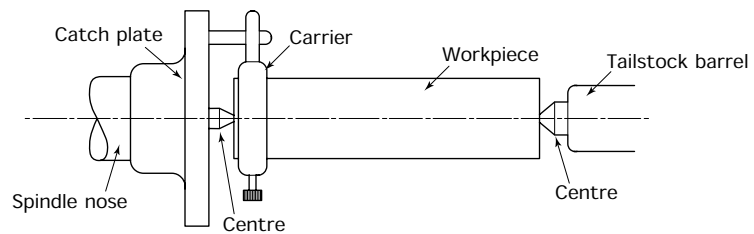


Figure 10.13 *Workholding between centres*

To ensure true running of the workpiece, the centres and the bores must be carefully cleaned before the centres are inserted. The tailstock centre does not rotate so it is made from hardened steel to prevent wear. It must be suitably lubricated. The headstock centre rotates with the spindle so there should be no wear and a hard centre is not necessary. Despite this, a hard centre is usually used in the spindle. It should be checked with a dial gauge (DTI) for true running. If after cleaning it still cannot be made to run true, a soft centre can be used and it is turned to the 60° taper position in the machine spindle to ensure true running.

It is also essential to drill the centre holes in the workpiece correctly. Figure 10.14(a) shows the preparation of a workpiece for holding between centres. The work is held in a three-jaw, self-centring chuck whilst the end of the work is faced off smooth and the centre hole is drilled (chucks will be considered in Sections 10.8 to 10.10 inclusive). The centre drill is held in a drill chuck. The drill chuck has a morse taper mandrel that fits in the barrel of the tailstock. A centre drill is designed and manufactured to produce a pilot hole and the taper location in one operation.

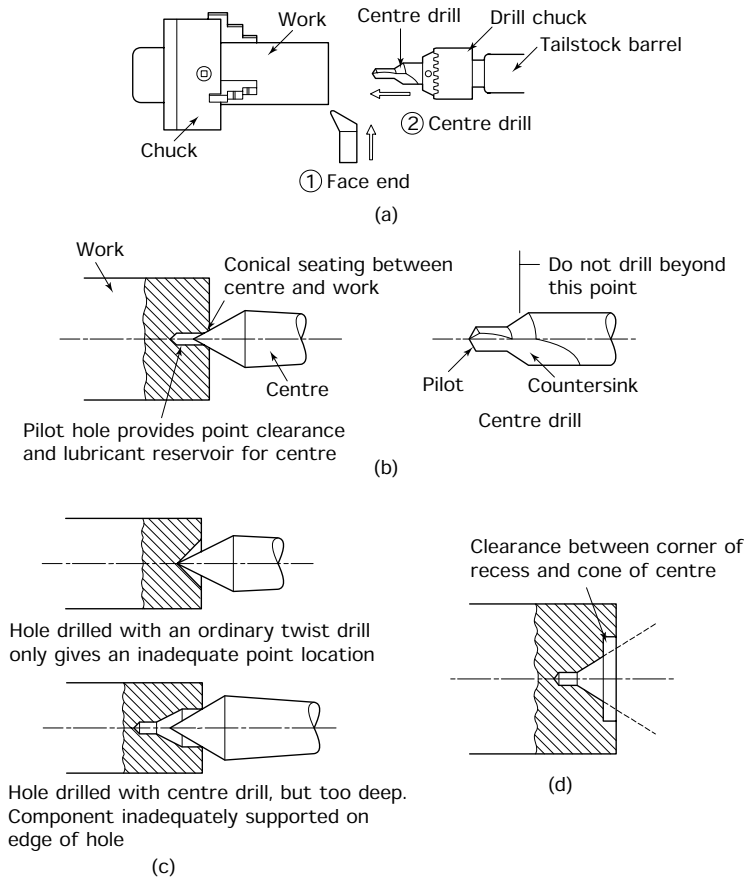


Figure 10.14 *The centre hole: (a) centring workpiece; (b) formation of the centre hole; (c) typical centre hole faults; (d) recessed or protected centre*

Figure 10.14(b) shows a correctly formed centre hole with the centre in position. Location should be on the flanks of the taper and not on the point of the taper. The pilot hole not only provides point clearance, it also provides a reservoir for lubricant. The essential features of a centre drill are also shown. These are usually double ended.

Figure 10.14(c) shows typical centre hole faults. If the centre hole becomes damaged, then the work will not run true. To stop the edges of the centre hole becoming bruised during handling, it can be recessed as shown in Fig. 10.14(d). This is called a *protected centre hole*.

Sometimes a rotating tailstock centre is used; an example is shown in Fig. 10.15. The centre is supported in ball bearings or in roller bearings that are designed to resist the radial and axial forces. Rotating centres are used where high spindle speeds are required, as when carbide-tipped tools are used, and for supporting heavy workpieces.

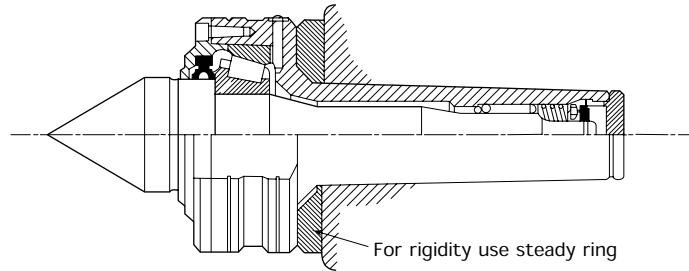


Figure 10.15 *Revolving tailstock centre (reproduced courtesy of Jones and Shipman plc)*

For parallel turning, the common axis of the spindle and the tailstock barrel must be parallel to the main bed slideways. The tailstock is provided with lateral (sideways) adjustment to achieve this end. When turning between centres a trial cut should be taken along the work. The diameter of the work is then checked at each end with a micrometer caliper. If the readings are the same, then the work is a true cylinder and the roughing and finishing cuts can be taken. If the readings are different, then the tailstock needs to be adjusted as shown in Fig. 10.16. Further trial cuts are taken after each adjustment until the diameter is constant along its whole length. The advantages and limitations of workholding between centres are listed in Table 10.1.

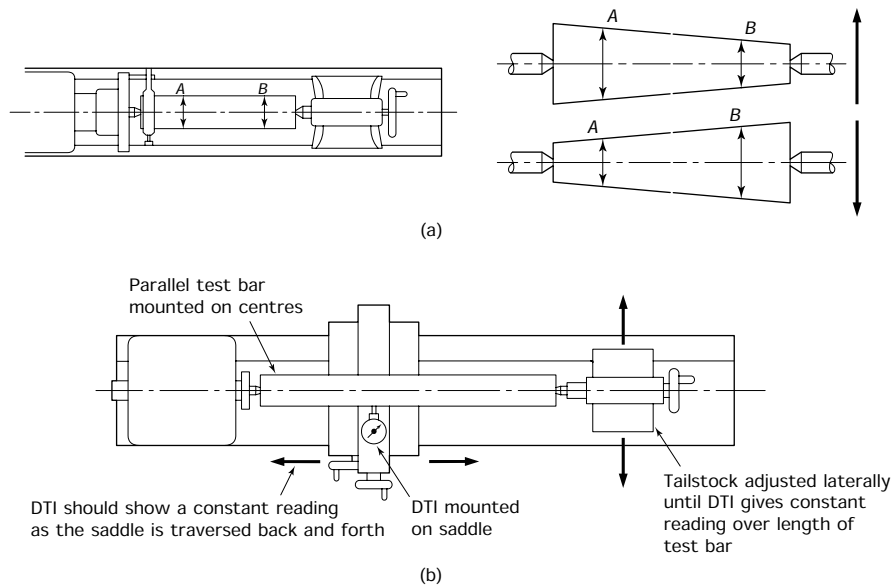


Figure 10.16 *Parallel cylindrical turning: (a) the axis of the headstock spindle must be in alignment with the tailstock barrel axis; if this is so the diameter A will be the same as diameter B; (b) use of test bar*

TABLE 10.1 *Workholding between centres*

<i>Advantages</i>	<i>Limitations</i>
<ol style="list-style-type: none"> 1. Work can be easily reversed without loss of concentricity 2. Work can be taken from the machine for inspection and easily re-set without loss of concentricity 3. Work can be transferred between machines (e.g. lathe and cylindrical grinder) without loss of concentricity 4. Long work (full length of bed) can be accommodated 	<ol style="list-style-type: none"> 1. Centre holes have to be drilled before work can be set up 2. Only limited work can be performed on the end of the bar 3. Boring operations cannot be performed 4. There is lack of rigidity 5. Cutting speeds are limited unless a revolving centre is used. This reduces accuracy and accessibility 6. Skill in setting is required to obtain the correct fit between centres and work

10.7 Workholding devices (taper mandrel)

Taper mandrels enable hollow components to be turned so that the external diameter runs true with the bore (that is, they are concentric) as shown in Fig. 10.17(a). A mandrel press, as shown in Fig. 10.17(b), is used to insert and remove the mandrel.

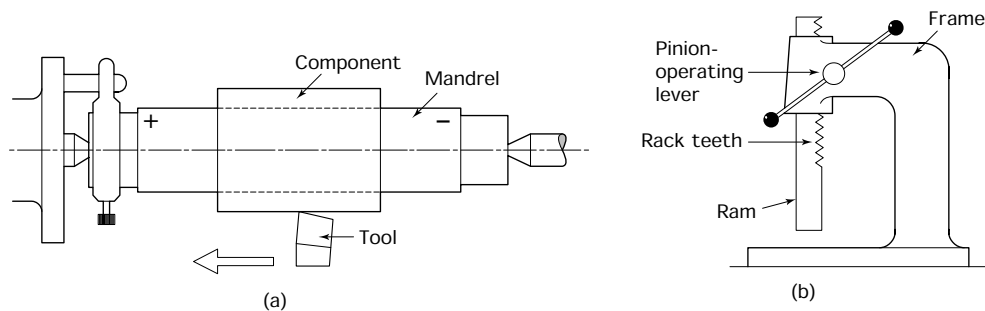


Figure 10.17 *The taper mandrel: (a) turning on the mandrel – the component is rough turned, bored and reamed to size, it is then pressed onto a mandrel set up between centres and the outside diameter is finished turned concentric with the bore, the mandrel is tapered so that the further the component is forced on, the more firmly it is held in place – therefore the direction of cutting should be towards the plus end of the mandrel; (b) the mandrel press*

Let's consider the component shown in Fig. 10.18(a). We could hold the component in a three-jaw chuck and drill it. If we want a hole of accurate size and roundness we could ream it. If the drilled hole 'runs out' we can correct it only by single point boring. However, it would be very difficult to make a boring tool that is sufficiently rigid, yet is long enough and small enough for the hole shown.

The alternative technique is shown in Fig. 10.18(b). Instead of trying to bore the hole true with the outside diameter, we make the hole first and then turn the outside diameter true with the bore as shown.

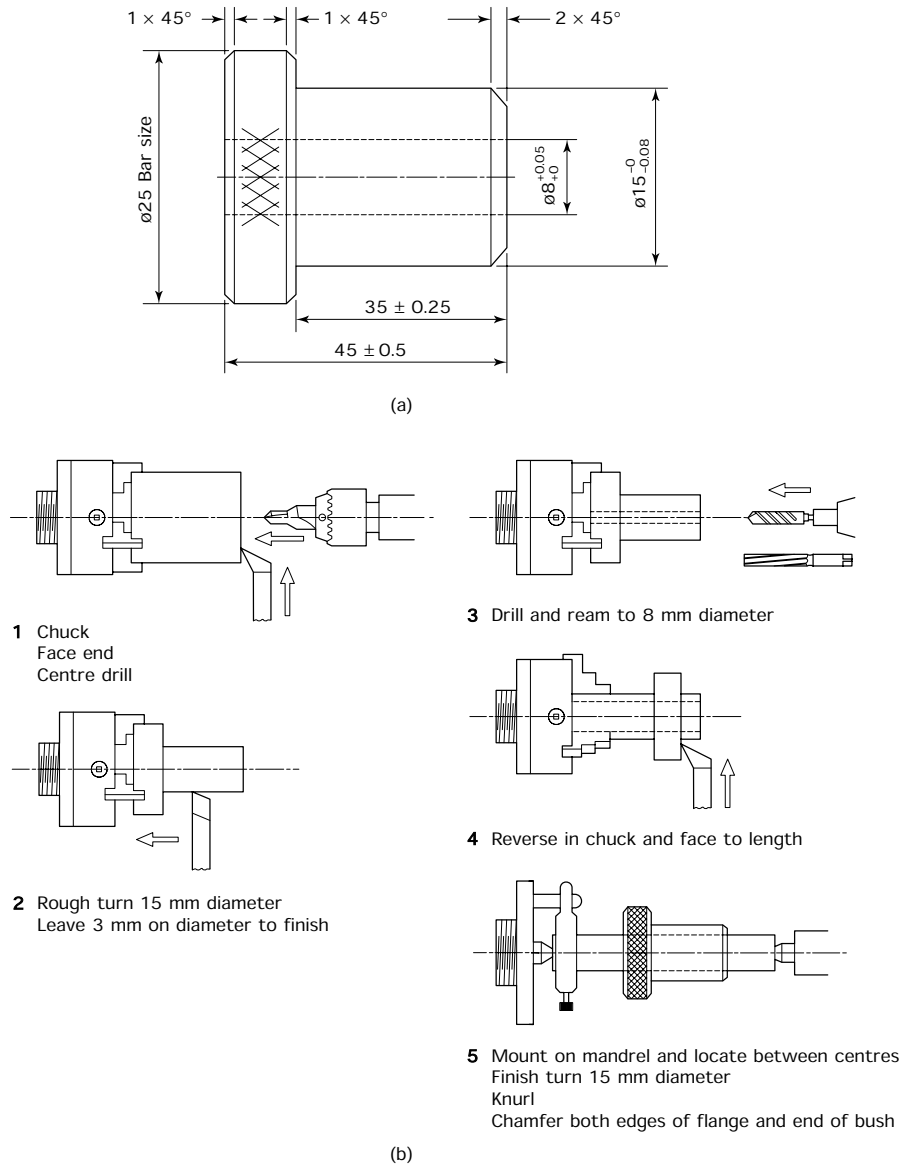


Figure 10.18 Turning a bush: (a) bush with small diameter bore; (b) turning on a mandrel

- First drill and ream the hole.
- Then mount the work on a *taper mandrel*. This is hardened and ground with a slight taper. The work is mounted so that the direction of the cutting forces tends to push the work towards the large end of the mandrel.

- A mandrel press (also called an arbor press) is used to insert the mandrel.
- The mandrel complete with the work is then mounted between centres.
- The outside of the work is then turned to size. It will then be concentric with the bore.
- The mandrel is removed with the mandrel press.

The advantages and limitations of using a mandrel as a workholding device are listed in Table 10.2.

TABLE 10.2 *Turning on a mandrel*

<i>Advantages</i>	<i>Limitations</i>
<ol style="list-style-type: none"> 1. Small-bore components can be turned with the bore and outside diameters concentric 2. Batch production is possible without loss of concentricity or lengthy setup time 3. The advantages of turning between centres also apply (see Table 4.1) 	<ol style="list-style-type: none"> 1. Bore must be a standard size to fit a taper mandrel. Adjustable mandrels are available but these tend to lack rigidity and accuracy 2. Cuts should only be taken towards the 'plus' end of the mandrel 3. Only friction drive available, and this limits size of cut that can be taken 4. Special mandrels can be made but this is not economical for one-off jobs 5. Items 2 to 5 of the limitations in Table 4.1 also apply here

10.8 Workholding devices (self-centring chuck)

Figure 10.19(a) shows the constructional details of a three-jaw, self-centring chuck, used for holding cylindrical and hexagonal workpieces. You can see that the scroll not only clamps the component in place, it also locates the component as well. Unfortunately, if the scroll becomes

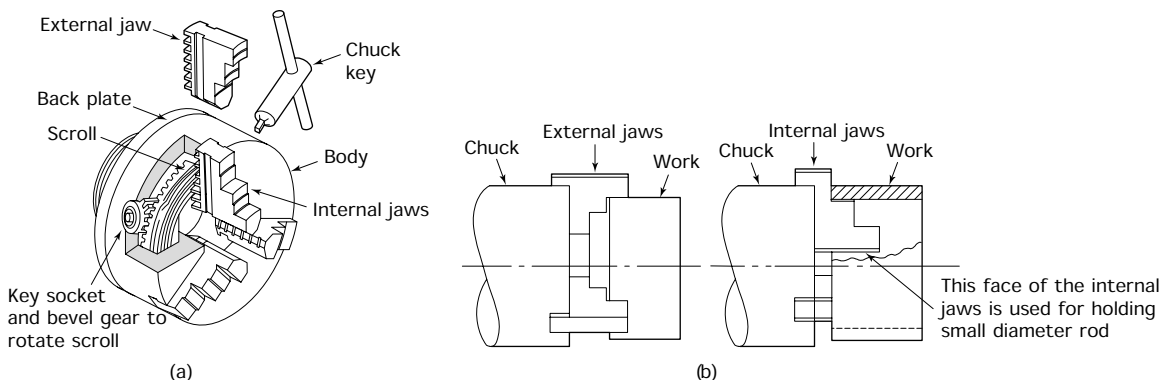


Figure 10.19 *The three-jaw, self-centring chuck: (a) construction; (b) external and internal jaws*

worn or damaged the chuck loses its accuracy. However, modern chucks are very accurate and maintain their accuracy over a long period of time provided they are used correctly and kept clean.

- *Never* try to hammer the work true if it is running out.
- *Never* hold work that is not round, such as hot-rolled (black) bar. Being out of round it will strain the jaws and the highly abrasive scale may also get into the scroll causing early wear.
- *Never* hold work on the tips of the jaws. This not only strains the jaws but the work is not held securely and safely.

The jaws for this type of chuck are *not* reversible. Separate internal and external jaws have to be used as shown in Fig. 10.19(b). When changing jaws the following points must be observed.

- Check that each jaw in the set carries the same serial number as the number on the chuck body.
- Make sure the jaws are numbered 1 to 3.
- Insert the jaws sequentially starting with number 1.

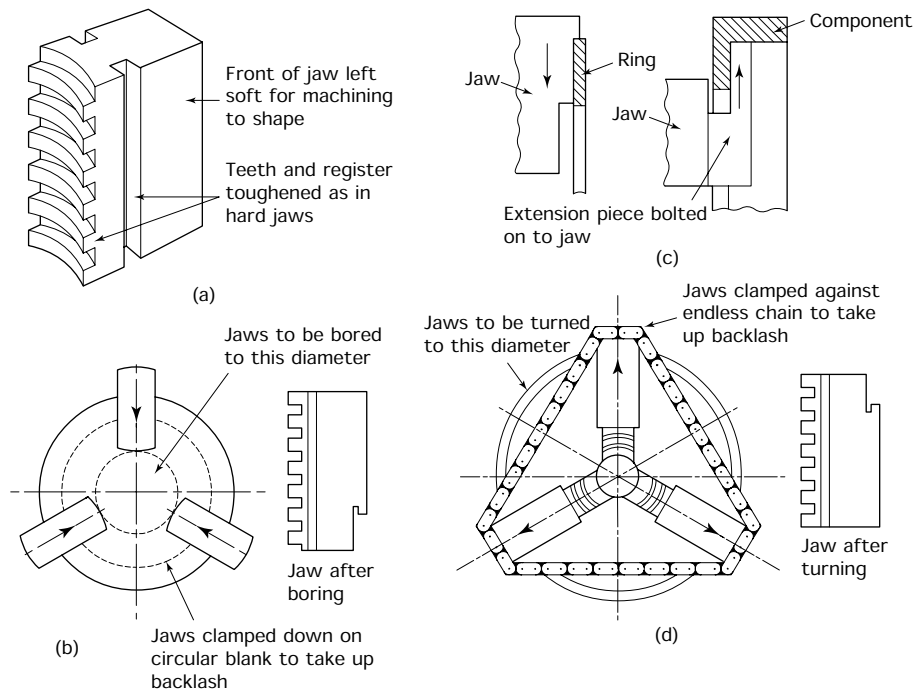


Figure 10.20 Use of soft jaws: (a) soft jaw; (b) boring soft jaws; (c) applications – (left) jaw bored to give maximum support to a thin ring whilst it is being bored and faced, (right) jaw fitted with extension piece to avoid holding onto and damaging the flange; (d) turning soft jaws

10.8.1 Soft jaws

When awkward components – such as thin discs – have to be held, or where greater accuracy is required from a three-jaw chuck, *soft jaws* can be used. These are inserted like any other jaws and the same rules apply. These jaws are not hardened but can be turned to the shape required whilst in position in the chuck. Figure 10.20 shows how they should be machined in order to eliminate backlash errors, and also shows a typical component where soft jaws are an advantage. The advantages and limitations of the self-centring chuck are listed in Table 10.3.

TABLE 10.3 *The self-centring chuck*

<i>Advantages</i>	<i>Limitations</i>
1. Ease of work setting	1. Accuracy decreases as chuck becomes worn
2. A wide range of cylindrical and hexagonal work can be held	2. Accuracy of concentricity is limited when work is reversed in the chuck
3. Internal and external jaws are available	3. 'Run out' cannot be corrected
4. Work can be readily performed on the end face of the job	4. Soft jaws can be turned up for second operation work, but this is seldom economical for one-off jobs
5. The work can be bored	5. Only round and hexagonal components can be held

10.9 Workholding devices (collets)

Collets of the type as shown in Fig. 10.21(a) are located in the taper bore of the spindle nose either directly or in a tapered adapter sleeve. The range of movement is very small and a separate collet is required for each bar size. The collets can be either pushed into the taper by a collar

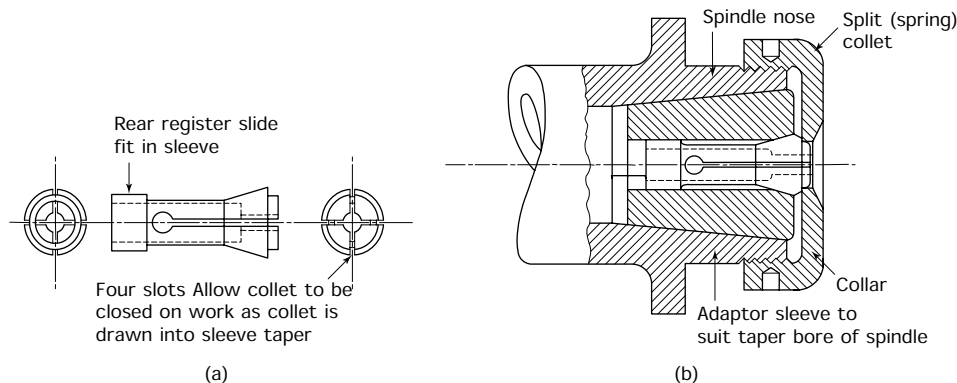


Figure 10.21 *The split-collet chuck: (a) split (spring) collet; (b) collet chuck for a simple plain nose spindle (typical of small instrument lathes) tightening the collar forces the collet back into the taper bore of the sleeve which closes the collet down onto the workpiece; (c) draw-bar collet chuck for taper nose spindles*

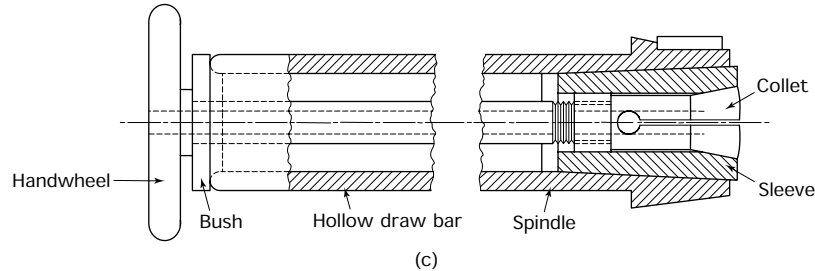


Figure 10.21 (continued)

as shown in Fig. 10.21(b). This system can be used only with plain nose spindles as found on some small bench lathes or alternatively, collets can be drawn into the taper by a hollow draw bar as shown in Fig. 10.21(c). This system can be used with taper nose spindles. The advantages and limitations of split collets mounted directly into the spindle bore are listed in Table 10.4.

TABLE 10.4 *The split-collet chuck*

<i>Advantages</i>	<i>Limitations</i>
<ol style="list-style-type: none"> 1. Very high accuracy of concentricity 2. Accuracy maintained over long periods of use 3. Simple, compact and reliable 4. Very quickly loaded 5. Considerable gripping power 6. Unlikely to mark or damage work 7. Work can be removed and replaced without loss of accuracy 8. Work can be turned externally, internally (bored) and end faced 9. No overhang from spindle nose reduces chatter and geometrical inaccuracy. Very useful where work has to be parted off 	<ol style="list-style-type: none"> 1. Only accurately turned, ground or drawn rod can be held in a collet 2. Separate collets have to be used for each size of rod. Range of adjustment very small 3. Although simple, initial cost is high due to the large number of collets that have to be bought 4. Range of sizes that can be held limited by bore of spindle 5. Work can only be held on external surfaces 6. Only collets with circular or hexagonal jaws are available from stock. Other sections have to be made to special order (costly) 7. Special adaptor sleeve required to suit bore of spindle nose

10.10 Workholding devices (four-jaw, independent chuck)

Figure 10.22 shows the constructional details of this type of chuck. It is more heavily constructed than the self-centring chuck and has much greater holding power. Each jaw is moved independently by a square thread screw and the jaws are reversible. These chucks are used for holding:

- Irregularly shaped work.
- Work that must be set to run concentrically.

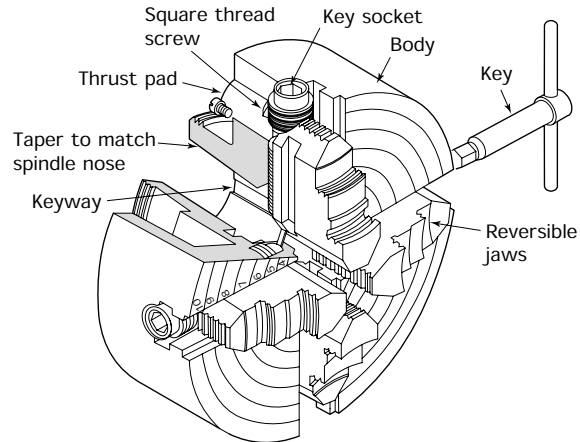


Figure 10.22 *The four-jaw chuck*

- Work that must be deliberately offset to run eccentrically. Eccentrically mounted work must be balanced to prevent vibration.

Since the jaws of a four-jaw chuck *can be reversed*, there is no need for separate internal and external jaws. Since the jaws move independently in this type of chuck, the component has to be set to run concentrically with the spindle axis by the operator. This is done when the work is mounted in the chuck.

- Figure 10.23(a) shows how a floating centre can be used to set the work concentrically with the intersection of previously scribed lines.

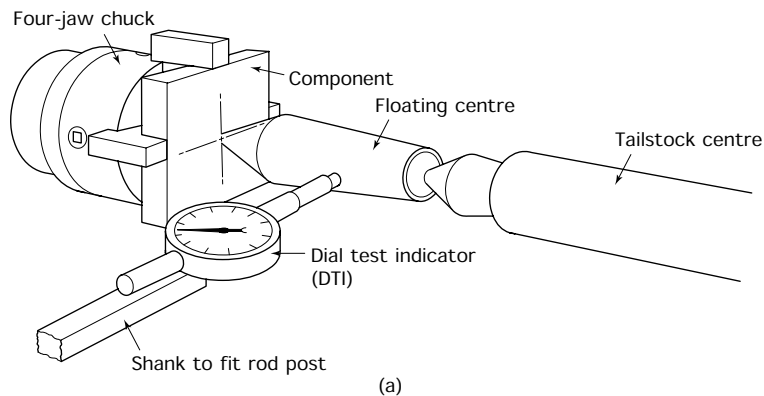


Figure 10.23 *The four-jaw chuck: work setting: (a) the chuck is adjusted until the DTI maintains a constant reading whilst the chuck is revolved; (b) the chuck is adjusted until the scriber point just touches each opposite edge or corner as the chuck is revolved; (c) dial test indicator will show a constant reading when component is set to run true*

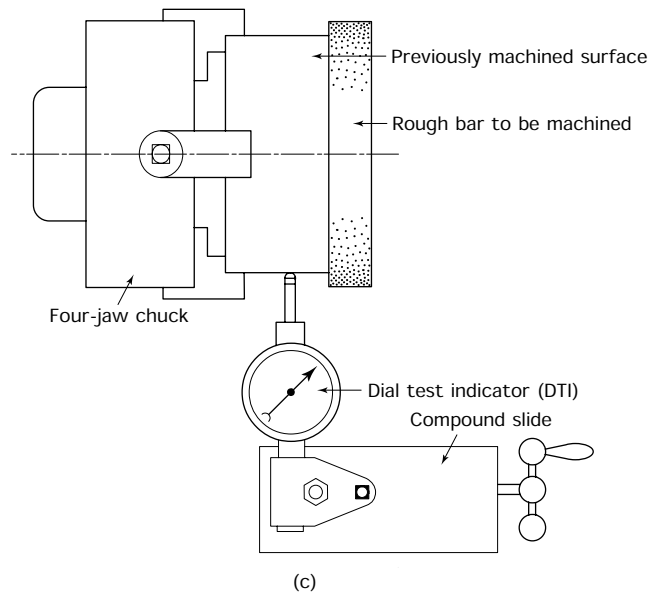
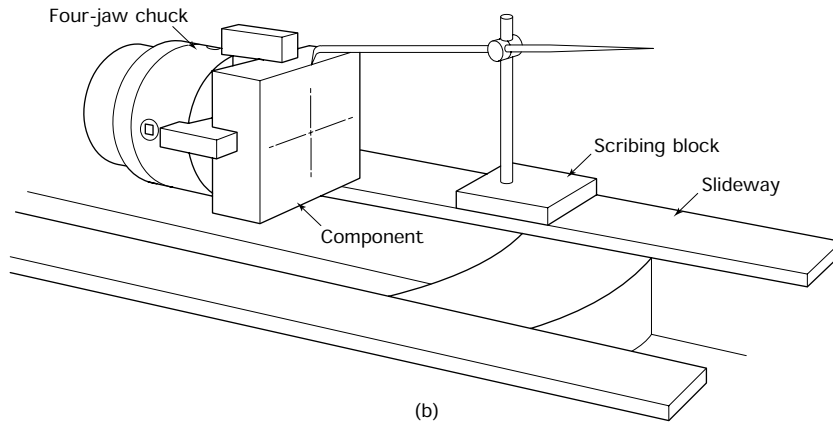


Figure 10.23 (continued)

Note that the setting will only be as accurate as the positioning of the centre punch mark.

- Figure 10.23(b) shows how work of lower accuracy can be set using a scribing block.
- Figure 10.23(c) shows how work may be set using a DTI to register on a previously machined surface. When correctly set the DTI should show a constant reading. All diameters turned at this setting will be concentric with the original diameter used for setting the workpiece.

The advantages and limitations of a four-jaw chuck are listed in Table 10.5.

TABLE 10.5 The four-jaw chuck

<i>Advantages</i>	<i>Limitations</i>
<ol style="list-style-type: none"> 1. A wide range of regular and irregular shapes can be held 2. Work can be set to run concentrically or eccentrically at will 3. Considerable gripping power. Heavy cuts can be taken 4. Jaws are reversible for internal and external work 5. Work can readily be performed on the end face of the job 6. The work can be bored 7. There is no loss of accuracy as the chuck becomes worn 	<ol style="list-style-type: none"> 1. Chuck is heavy to handle on to the lathe 2. Chuck is slow to set up. A dial test indicator (DTI) has to be used for accurate setting 3. Chuck is bulky 4. The gripping power is so great that fine work can be easily damaged during setting

10.11 Workholding devices (faceplate)

The workholding devices previously described are designed so that a diameter may be machined true to another existing diameter. However, the faceplate enables a component to be mounted so that the workpiece can be turned either *parallel* or *perpendicular* to a previously machined flat surface.

- In Fig. 10.24(a) the axis of the bore will be *perpendicular* to the datum surface of the workpiece. That is, to the previously machined flat base of the component which is clamped directly to the faceplate.

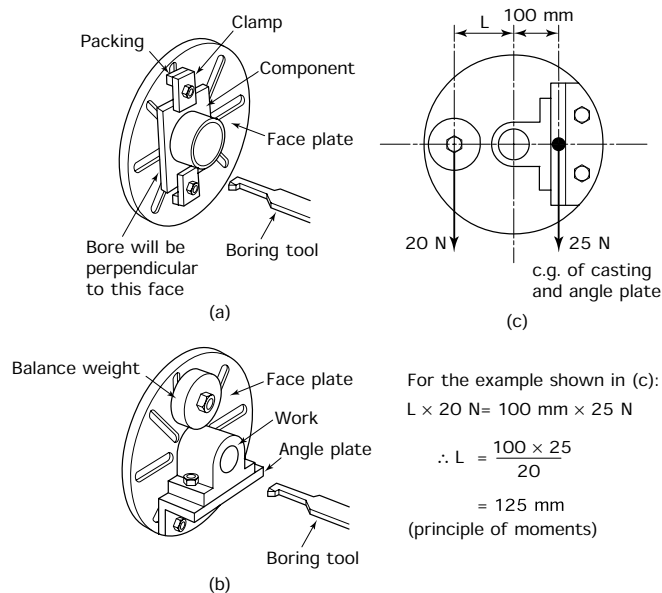


Figure 10.24 The faceplate: (a) balanced work; (b) unbalanced work; (c) positioning the balance weight

- In Fig. 10.24(b) the axis of the bore will be *parallel* to the datum surface. That is, to the previously machined flat base of this component that is mounted on an angle plate bolted to the faceplate.

In the example shown in Fig. 10.24(a), the work is symmetrical about the spindle centre line and no balance weight is required. However, in Fig. 10.24(b), the work is offset and unbalanced so a balance weight has had to be added to ensure the smooth running of the set-up at the machining speed required. This is to prevent out-of-balance forces from causing vibrations that could damage the spindle bearings of the machine or, in extreme cases, cause the machine to rock dangerously on its mountings. Offset components in a four-jaw chuck must also be balanced in a similar manner. Figure 10.24(c) shows how the balance weight is positioned. The advantages and limitations of using a faceplate are listed in Table 10.6.

TABLE 10.6 *The faceplate*

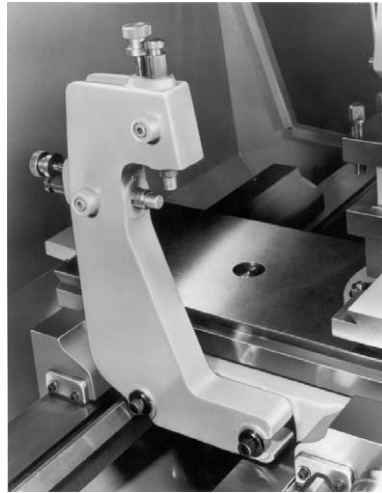
<i>Advantages</i>	<i>Limitations</i>
1. A wide range of regular and irregular shapes can be held	1. The face plate is slow and tedious to set up. Not only must the workpiece be clocked up to run true, clamps must also be set up on the face plate to retain the component
2. Work can be set to a datum surface. If the datum surface is parallel to the workpiece axis, it is set on an angle plate mounted on the face plate. If the datum surface is perpendicular to the workpiece axis, the workpiece is set directly on to the face plate	2. Considerable skill is required to clamp the component so that it is rigid enough to resist both the cutting forces, and those forces that will try to dislodge the work as it spins rapidly round
3. Work on the end face of the job is possible	3. Considerable skill is required to avoid distorting the workpiece by the clamps
4. The work can be bored	4. Irregular jobs have to be carefully balanced to prevent vibration, and the job rolling back on the operator
5. The work can be set to run concentrically or eccentrically at will	5. The clamps can limit the work that can be performed on the end face
6. There are no moving parts to lose their accuracy with wear	
7. The work can be rigidly clamped to resist heavy cuts	

10.12 Use of steadies

The workholding devices discussed so far assume that the workpiece is sufficiently rigid to be self-supporting. However, this is sometimes not the case, and additional support has to be provided. If the workpiece is long and slender it will visibly deflect and either climb over the cutting tool or spring out of the centres, or both, resulting in damage to the workpiece, damage to the cutting tool and, possibly, serious injury to the machine operator.

10.12.1 Travelling steady

To balance the cutting forces and prevent the component from deflecting a *travelling steady* is used. An example of such a steady is shown in Fig. 10.25(a). The steady is mounted on the carriage of the lathe opposite



(a)

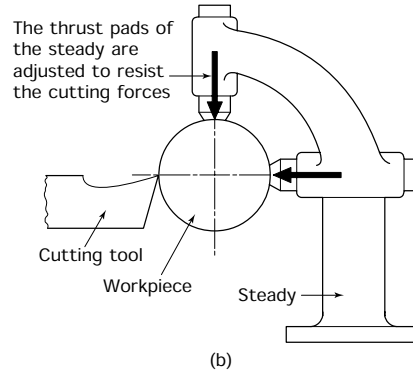


Figure 10.25 *The travelling steady mounted on the saddle (a); the action of the steady (b) (photograph reproduced courtesy of Colchester Lathe Co.)*



Figure 10.26 *The fixed steady (photograph reproduced courtesy of Colchester Lathe Co.)*

the cutting tool. As the saddle traverses along the bed of the lathe the steady moves with it, hence its name. Figure 10.25(b) shows how the adjustable, bronze thrust pads of the steady are positioned so that the work cannot deflect away from the cutting edge of the tool.

10.12.2 Fixed steady

The *fixed steady*, as its name implies, is fixed to the bed of the lathe. A typical fixed steady is shown in Fig. 10.26. It is used for two purposes:

- To support the end of long workpieces that cannot be held on a centre, for example if the end of the component has to be faced and bored.
- As a safety precaution when large and heavy components are supported on a tailstock centre. In this latter case the centre supports and locates the work, and the thrust pads of the steady are set to *just clear* of the work so as not to interfere with the alignment. However, if the centre fails under the load, the work merely drops a fraction of a millimetre and rests in the fixed steady. Otherwise it would break free from the lathe, doing considerable damage to the machine and causing serious injury to the operator.

10.13 Lathe tool profiles

The profile of a lathe tool is the shape of the tool when viewed from above. Figure 10.27 shows a selection of lathe tools and states their typical applications. A lathe tool is selected to suit the job to be done. The rake angle is indicated by the letter R and the direction of the rake is indicated by the associated arrow. Chip formation and the geometry of lathe tools will be considered in Section 10.20.

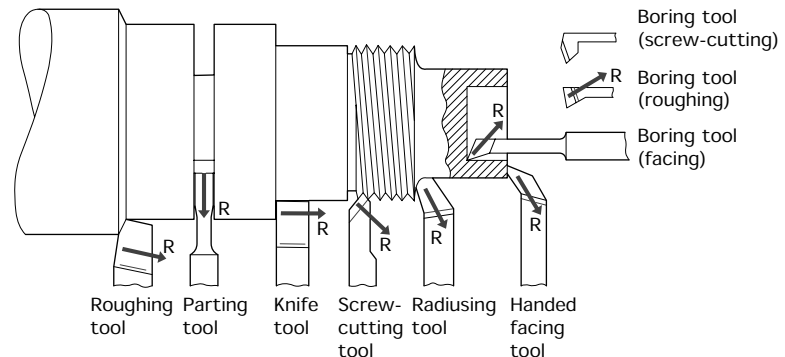


Figure 10.27 Lathe tool profiles: these tools are right handed; left-hand tools cut towards the tailstock; the arrows indicate the rake angle (R) of each tool

10.14 Concentricity

When a component is being turned it is usual to try to keep the various diameters *concentric*. That is, we try to ensure that all the diameters of

a component *have a common axis*. The meanings of concentricity and eccentricity are shown in Fig. 10.28.

In Fig. 10.28(a) the two diameters A and B are *concentric*. They have the same centre of rotation and lie on the same axis. In Fig. 10.28(b) the two diameters A and B are *eccentric*. They have different centres of rotation and do not lie on the same axis. The distance *E* between the two centres of rotation is the amount of 'offset' or eccentricity.

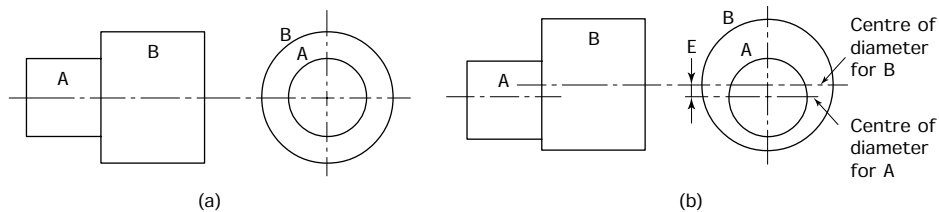


Figure 10.28 *Concentricity and eccentricity: (a) concentric diameters – both have the same centre; (b) eccentric diameters – each diameter has a different centre*

The easiest way to ensure concentricity is to turn as many diameters at the same setting as possible without removing the work from the lathe, as shown in Fig. 10.29. If the work does have to be removed from the lathe in order to turn it round, then it must be mounted in a four-jaw chuck and trued up using a dial test indicator on a previously machined diameter. Work held between centres can be removed and reversed as many times as is necessary without loss of concentricity.

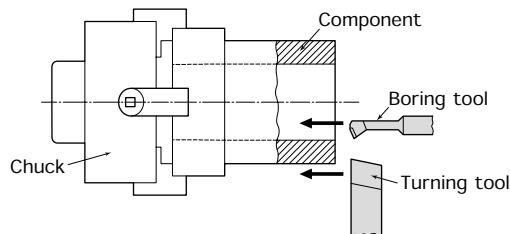


Figure 10.29 *Maintaining concentricity: both the bore and the outside diameter are turned at the same setting*

10.15 Taper turning

Earlier in this chapter we discussed the conditions necessary to produce a cylindrical component. Great emphasis was laid on the importance of maintaining the axial alignment of the headstock spindle and the tailstock barrel, together with the need for the cutting tool to move in a path parallel to this common axis.

Now we are going to consider the conditions for producing tapered (conical) components. Taper turning involves the controlled disturbance of the alignments previously described so that the tool moves in a path that is no longer parallel to the common headstock spindle and tailstock

barrel axis but is inclined to it. This inclination is relative. The same effect is produced no matter whether the tool path is inclined to the axis, or whether the axis is inclined to the tool path. Three methods of taper turning will now be described.

10.15.1 Offset tailstock

Using the lateral adjusting screws, the body of the tailstock and, therefore, the tailstock centre can be offset. This inclines the axis of the workpiece relative to the path of the cutting tool when the workpiece is held between centres as shown in Fig. 10.30(a). The advantages and limitations of this technique are listed in Table 10.7.

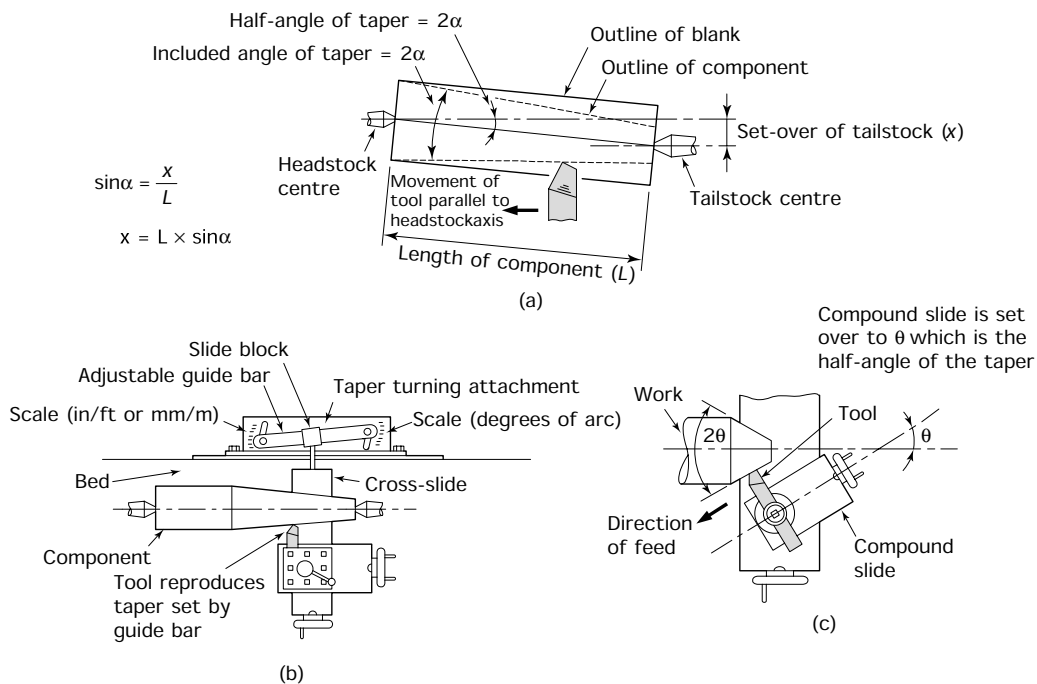


Figure 10.30 Taper turning: (a) set over of centres; (b) the taper turning attachment; (c) compound slide

10.15.2 Taper-turning attachment

Another way in which tapers may be produced is by the use of a taper-turning attachment. This is usually an 'optional extra' that can be purchased separately and bolted to the back of the lathe. Such attachments differ in detail from manufacturer to manufacturer but the principle remains the same. The movement of the cross-slide and, therefore, the tool path is controlled by the guide bar of the attachment as shown in Fig. 10.30(b). This can be set to the desired angle, and clamped in position. As the carriage traverses along the bed, the tool is moved into

the workpiece or away from the workpiece according to the setting of the guide bar. In either case a taper is produced. If the work is supported between centres, then these are aligned as for cylindrical turning. The advantages and limitations of this technique are listed in Table 10.7.

TABLE 10.7 *Comparison of taper turning techniques*

<i>Method</i>	<i>Advantages</i>	<i>Limitations</i>
Set-over (offset) of tailstock	<ol style="list-style-type: none"> 1. Power traverse can be used 2. The full length of the bed used 	<ol style="list-style-type: none"> 1. Only small angles can be accommodated 2. Damage to the centre holes can occur 3. Difficulty in setting up 4. Only applies to work held between centres
Taper turning attachments	<ol style="list-style-type: none"> 1. Power traverse can be used 2. Ease of setting 3. Can be applied to chucking and centre work 	<ol style="list-style-type: none"> 1. Only small angles can be accommodated 2. Only short lengths can be cut (304–457 mm/12–18 in) depending on make
Compound slide	<ol style="list-style-type: none"> 1. Very easy setting over a wide range of angles (Usually used for short, steep tapers and chamfers) 2. Can be applied to chucking, and centre work 	<ol style="list-style-type: none"> 1. Only hand traverse available 2. Only very short lengths can be cut. Varies with m/c but is usually limited to about 76–101 mm (3–4 in)

10.15.3 Compound slide

Setting over the compound slide also inclines the tool path relative to the workpiece axis as shown in Fig. 10.30(c). For ease of setting this slide has a protractor base calibrated in degrees of arc. This is the simplest method of turning tapers but it does have some limitations. The advantages and limitations of this technique are listed in Table 10.7.

10.16 Hole production

Hollow as well as solid components can be produced on a centre lathe. The hole will be concentric with the spindle axis. If the required hole is not in the centre of the job then the job has to be offset relative to the spindle axis. The holes may be produced by:

- Drilling.
- Reaming.
- Boring.
- A combination of the above processes.

10.16.1 Drilling

The drilling of centre holes in the ends of components prior to turning them between centres has already been considered. The drilling of deeper holes or the drilling of holes completely through the component is a similar process. For small diameter holes up to 12.5 mm (1/2 inch) diameter you should adopt the following procedure. The centre drill is held in a drill chuck fitted with a morse taper shank. The shank of the chuck is inserted sharply into the taper bore of the tailstock barrel so that it seats securely. It is important that:

- The shank of the chuck is clean and free from damage.
- The bore of the tailstock barrel is clean.
- The chuck is seated firmly so that it will not rotate and damage the bore of the tailstock barrel. Damage to this bore would destroy the basic accuracy of the machine.

The hole is started with a centre drill. The centre drill is replaced with a drill slightly smaller than the size of the hole required. The hole is drilled to the required depth. This is aided by a rule type scale engraved on the tailstock barrel. Having produced a *pilot hole*, the pilot drill is replaced by a drill of the required size. The hole is now opened up to the drawing size.

Where larger holes are required, the drills may be too large to fit into a drill chuck. In which case, after drilling the pilot hole, the hole is opened up as follows:

- Open up the pilot hole with the largest drill that can be held in the chuck.
- Wind the tailstock barrel (poppet) right back until the chuck is ejected.
- Insert *taper shank drills* directly in the tailstock barrel to enlarge the hole in stages until the required size is reached.
- Take care that the taper bore in the spindle is not damaged by the largest drill when drilling right through the component.

Producing holes with a twist drill is a convenient way of achieving rapid metal removal. However, a drill does not produce a precision hole. The limitations of drilled holes are:

- Poor finish compared with drilling and reaming.
- Lack of dimensional accuracy.
- Lack of 'roundness' or geometrical accuracy.
- Lack of positional accuracy as the drill tends to wander, especially when drilling deep holes in soft material such as brass.

10.16.2 Reaming

The finish and accuracy of a hole are greatly improved if it is drilled slightly undersize and finished with a reamer. Reamers and reaming techniques in drilling machines were discussed in Section 9.6 and the same comments apply to reaming in the centre lathe. The reamer should be held in a 'floating' reamer holder of the type shown in Fig. 10.31. This allows the reamer to follow the previously drilled hole without flexing. The ability of the reamer to float prevents ovality and 'bell-mouthing' in the reamed hole produced. Providing the correct speed has been used (less than for drilling), the reamer is fed into the work slowly, and as a coolant is used, a hole of good finish and roundness should be produced. However, the limitations of reaming are:

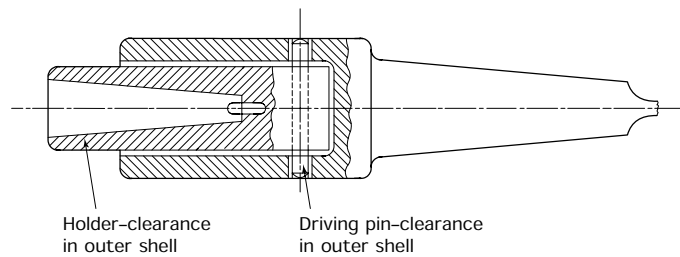


Figure 10.31 *Floating reamer holder*

- Lack of positional accuracy since the reamer follows the axis of the drilled hole and reproduces any 'wander' that may be present.
- Unless the quantities of components being produced warrants the cost of special tooling, only holes whose diameter is the same as standard reamer sizes can be produced.

Where a hole is too small to bore accurately, it is usual to drill and ream the hole to size than mount the component on a mandrel supported between centres. The outside of the component is then turned true with the hole (see Section 10.7). In this case the initial 'wander' of the drilled hole is unimportant.

10.16.3 Boring

Figures 10.32(a) and 10.32(b) show solid boring tools for use with small diameter holes, whilst Figs 10.32(c) and 10.32(d) show boring bars with inserted tool bits for larger diameter holes. Figure 10.32(e) shows the need for *secondary clearance* to prevent the heel of the tool from fouling the wall of small diameter bores. Holes produced by such tools are usually

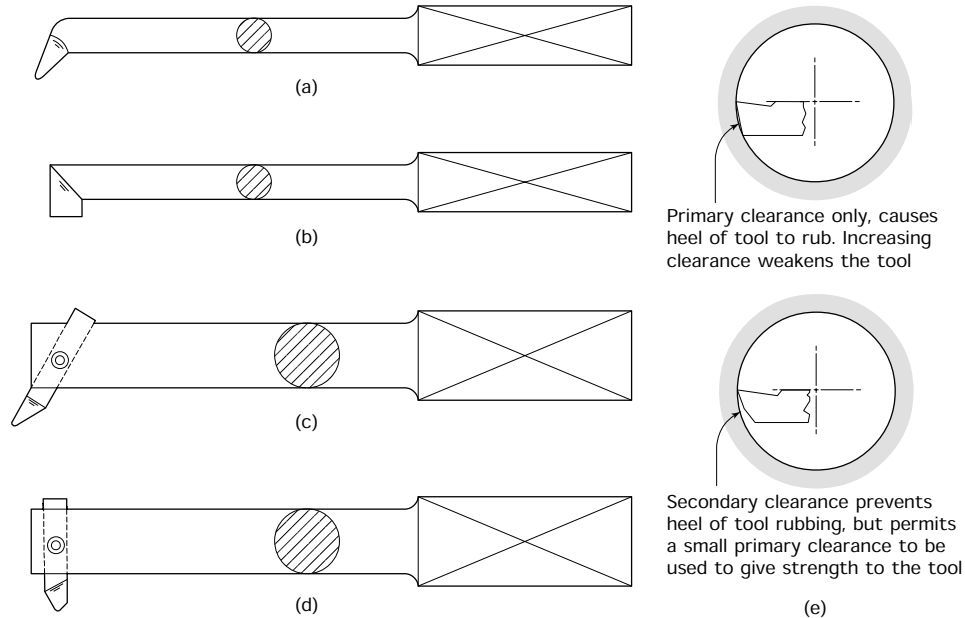


Figure 10.32 Centre lathe boring tools: (a) solid bottoming tool for blind holes; (b) solid roughing tool for a through hole; (c) boring bar with inserted tool for bottoming a blind hole; (d) boring bar with inserted tool for roughing a through hole; (e) need for secondary clearance

referred to as *bores*. Boring is the only way for correcting any axial wander in previously drilled pilot holes.

Because of the relatively slender shank of a boring tool and the long overhang of the tool point from the tool post, where the tool is secured, boring tools are prone to ‘chatter’ and leave a poor finish. Also the cut is liable to run off due to deflection of the tool shank. For this reason boring is a skilled operation compared with external turning. It requires careful grinding of the cutting tool to the correct shape, and careful selection of the speeds and feed rates.

10.17 Parting off

Where a number of small components have to be turned, such as the component shown in Fig. 10.33(a), it is easier to work from the bar than from previously sawn off blanks. The component is turned to shape on the end of the bar whilst being held in a three-jaw chuck. When finished the component is cut from the bar using a parting-off tool as shown in Fig. 10.33(b).

Figure 10.33(c) shows how a parting tool is ground. You can see that in addition to the usual rake and clearance angles, the tool also requires side clearance and plan (horizontal) clearance to prevent it rubbing on the sides of the groove. This is similar in effect to the set of a saw blade.

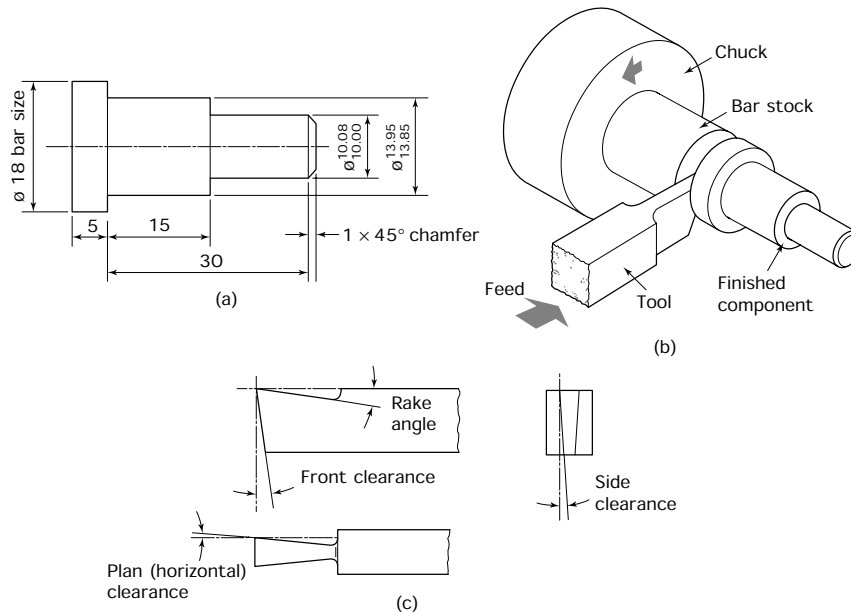


Figure 10.33 *Turning from the bar: (a) component – dimensions in millimetres; (b) parting component from the bar; (c) parting-off tool*

10.18 Cutting screw threads

The cutting of screw threads from the lead screw using single point tools is beyond the scope of this book.

10.18.1 External screw threads

The cutting of screw threads at the bench using a split button die in a diestock (dieholder) has already been considered. A similar technique can be used on a lathe with the added advantage that the thread will be true with the axis of the component.

Figure 10.34 shows a tailstock dieholder. The diestock body slides along a parallel mandrel mounted in the barrel of the tailstock. This ensures that the die is square with the work all the time it is cutting. The dieholder body is kept from rotating by the torque arm. Various diameter dies may be accommodated by changing the dieholder on the front of the body. The securing bolts are in clearance holes and should be only 'finger tight'. This allows the die to align itself axially with the work.

This arrangement is sufficiently rigid to allow threads to be cut with the lathe spindle rotating under power at a low speed. Before starting the machine ensure that the dieholder torque arm is safely engaged with the compound slide of the machine. The taking of roughing and finishing cuts and the use of a screw-cutting compound are as described previously. The lathe motor is switched to reverse for unscrewing the die. Again ensure that the torque arm is engaged with a suitable part of the carriage to

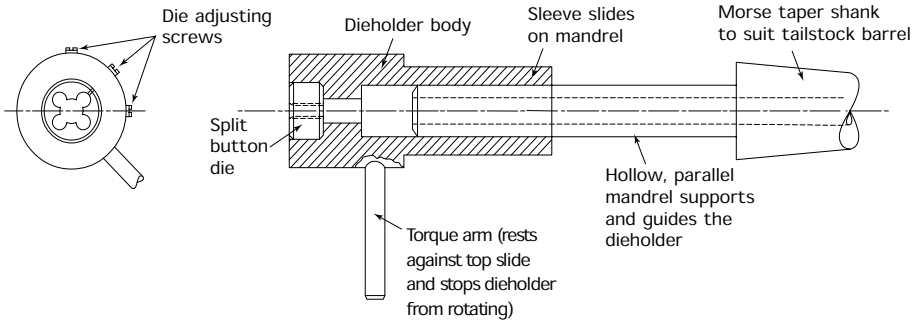


Figure 10.34 Tailstock dieholder

prevent reverse rotation, and is free to move along as the die unscrews, before starting the machine.

10.18.2 Internal screw threads

A tapping attachment similar to the tailstock dieholder previously described is shown in Fig. 10.35. The tap is held in the three-jaw chuck.

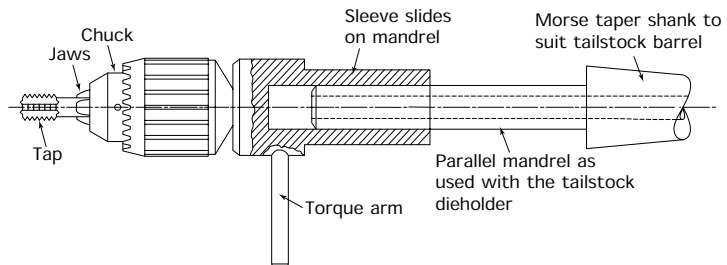


Figure 10.35 Tailstock tapholder

- Make sure the machine is turned off and put the gearbox into a neutral position.
- Hold the chuck from moving with your left hand and rotate the tap with your right hand using the torque arm of the tap holder.
- When you have rotated the tap as far as is convenient (about half a turn), rotate the chuck towards you, hold in position and rotate the tap again with the torque arm.
- Reverse the direction of rotation after every revolution or so to break up the chips and relieve the load on the tap. A screw-cutting compound should be used to lubricate the tap. There is a limit to the size of tap that can be held in the chuck without the tap slipping.

10.19 Knurling

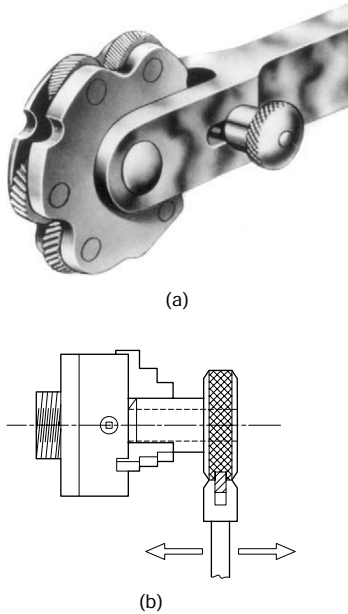


Figure 10.36 *Knurling: (a) knurling tool fitted with three pairs of knurls; coarse, medium and fine – the positive locking device is for use when single knurling only; (b) use of a knurling tool (photograph reproduced courtesy of Jones and Shipman plc)*

This process produces a rough pattern on the turned surface so that it can be held and rotated by hand without slipping. Figure 10.36(a) shows a typical knurling tool. You can see that it consists of three pairs of grooved rollers. One pair produces a coarse knurl, the second pair can be used to produce a medium knurl and the third pair can be used to produce a fine knurl.

- Considerable force is required to make the knurling rollers bite into the metal of the workpiece, so the work should protrude from the chuck only for the minimum possible distance or it will need to be supported with a centre.
- Make sure the knurling tool is clean and free from swarf, select the pair of rolls for the coarseness of knurl required. (Rollers with alternative groove patterns are available for special purposes, but the usual pattern produces a diamond-shaped knurl.)
- Feed the knurling tool against the work gently with your right hand, using the cross-slide handwheel, whilst guiding the knurling head with your left hand until the rollers are firmly in contact with the work.
- Start up the lathe and, using a low spindle speed, traverse the knurling tool from side to side using the carriage traverse handwheel as shown in Fig. 10.36(b). At the same time increase the pressure on the rollers by means of the cross-slide handwheel.
- When the required pattern has been obtained, engage the power traverse (using a coarse rate of feed setting) and knurl along the work for the required distance. Use a flood of coolant not only to lubricate the rollers but also to wash away the swarf which might otherwise clog the rollers and spoil the pattern.
- When the required knurl has been achieved, wind off the cross-slide quickly and stop the traverse.
- Finally chamfer the end of the component to remove the ragged edge at the start of the knurl.

10.20 Chip formation and the geometry of lathe tools

There are three basic types of chip produced when cutting metals:

- Discontinuous chip.
- Continuous chip.
- Continuous chip with a built-up edge.

10.20.1 Chip formation

Discontinuous chip

The cutting action of a normal wedge-shaped cutting tool causes the metal to try to pile up ahead of the tool until the forces involved cause the piled-up metal to shear off from the workpiece along a shear plane as shown

in Fig. 10.37(a). This is a continuous process of piling up and shearing off as shown. If the metal being cut is brittle, for example cast iron or free-cutting brass, the sheared-off pieces of metal will be quite separate and form the flaky or granular type of chip, called a *discontinuous chip*, as shown in Fig. 10.37(b).

Continuous chip

This type of chip is formed when ductile metals such as steel are being cut. Complete separation of the metal along the shear planes does not take place and a continuous ribbon type chip is formed as shown in Fig. 10.37(c). The outer face of the chip rubs against the rake face of the tool and is burnished smooth. The inside of the chip remains rough. Long, ribbon like chips may look spectacular as they coil away from the tool, but their razor sharp, ragged edges are extremely dangerous.

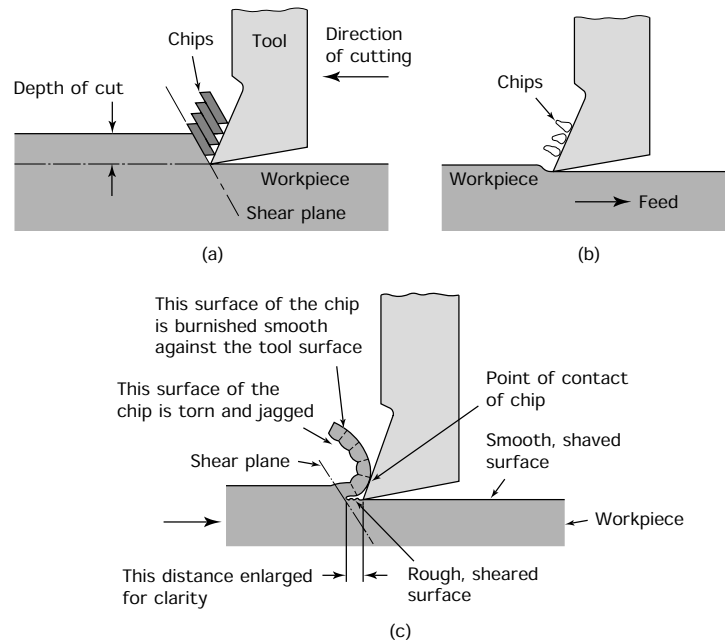


Figure 10.37 Chip formation: (a) chip formation; (b) discontinuous chip; (c) continuous chip for ductile, low-strength metals

Continuous chip with built-up edge

Under some conditions the friction between the chip and the rake face of the tool is very great. The combination of the contact pressure and the heat generated causes particles of metal from the chip to become pressure welded to the rake face of the tool as shown in Fig. 10.38(a). This makes the rake face of the tool rough at the cutting edge and increases the

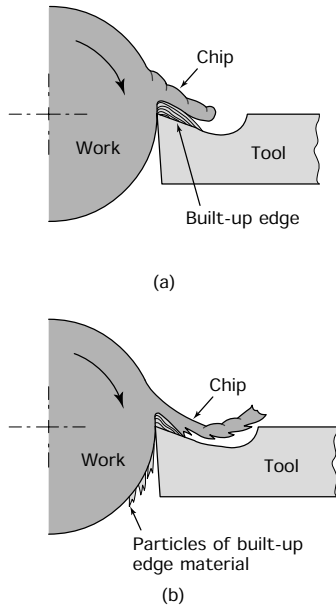


Figure 10.38 Chip welding (built-up edge): (a) layers of chip material form on the rake face of the tool; (b) excessive chip welding produces an unstable built-up edge; particles of built-up edge material flake away and adhere to the workpiece, making it rough and spoiling the surface finish

friction. This causes layer upon layer of metal to become built up, until a *built-up edge* is formed. A built-up edge masks the real cutting edge and the tool behaves as though it was blunt. Overheating occurs and the surface finish of the work is poor.

Eventually the amount of built-up metal increases to such an extent that it tends to become unstable and breaks down. The particles of built-up metal that flake away weld themselves to the chip and to the workpiece as shown in Fig. 10.38(b). This produces a dangerously jagged chip and a rough surface on the workpiece. The formation of a built-up edge is also referred to as *chip welding*.

10.20.2 Prevention of chip welding

Since chip welding has a considerable and adverse effect on tool life, power consumption, and surface finish, every attempt must be made to prevent it occurring. This is largely achieved by reversing the conditions that cause chip welding in the first place.

Reduction of friction

This can be achieved by increasing the rake angle, using a cutting fluid that is an extreme pressure lubricant as well as a coolant, and polishing the rake face.

Reducing the pressure

This can be achieved by increasing the rake angle. Remember this also weakens the tool and there is a limit to how far the rake angle can be increased for any given workpiece material. The pressure can also be reduced by increasing the approach angle of the tool. This reduces the chip thickness without reducing the rate of metal removal (see Section 10.23.1). Reducing the rate of feed and increasing the depth of cut the rate of metal removal whilst reducing the chip pressure on the tool (see Section 10.23.1).

Reducing the temperature

This can also be achieved by any of the above solutions. The temperature can also be achieved by reducing the spindle speed but this reduces the rate of metal removal.

Preventing metal to metal contact

This can be achieved by the use of a lubricant containing an extreme pressure additive. Such additives are usually sulphur or chlorine compounds. These additives tend to build up a non-metallic film on the surfaces of the tool and the chip. Since metal is not then in contact with metal chip welding cannot take place. Unfortunately active sulphur compounds attack copper and its alloys and should not be used on such metals. The use of

non-metallic cutting tools such as tungsten carbide also helps to reduce the opportunity for a built-up edge to form.

10.20.3 Geometry of the lathe tool

The principles of cutting tool angles have already been discussed. These angles are applied to turning tools as shown in Fig. 10.39(a). In addition, we have to consider the *profile* of lathe tools. If the cutting edge is at *right angles* to the direction of feed, the tool is said to be cutting *orthogonally* as shown in Fig. 10.39(b). If the cutting edge is *inclined* so that it trails the direction of feed, it is said to be cutting *obliquely* as shown in Fig. 10.39(c). The purpose of an oblique *plan approach angle* is twofold:

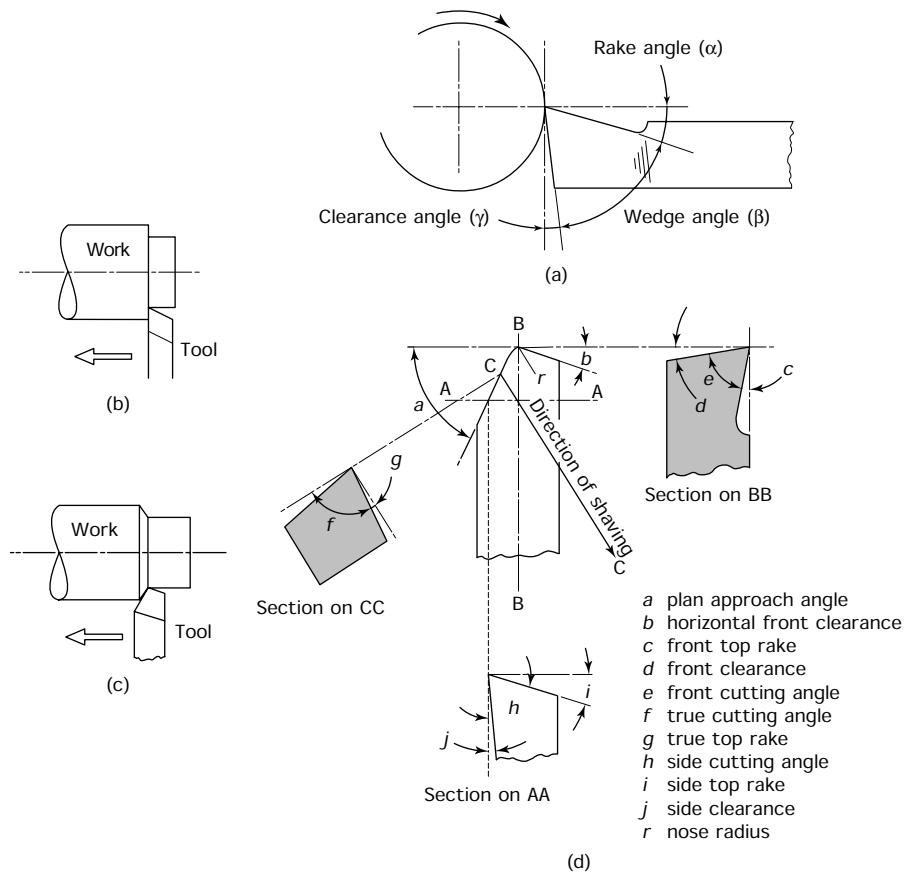


Figure 10.39 Lathe tool angles: (a) cutting applied to an orthogonal turning tool; (b) orthogonal cutting – the cutting edge is perpendicular to the direction of feed, this is useful for producing a square shoulder; (c) oblique cutting – the cutting edge is inclined to the direction of feed, this is the most efficient form for rapid metal removal; (d) cutting angles applied to an oblique turning tool

- To reduce the chip thickness, and therefore the load on the tool, whilst maintaining the same rate of material removal (see Section 10.23.1).
- To produce a back force on the tool. Wear of the cross-slide screw and nut results in 'backlash'. Without a back force on the tool, the forces acting on the rake face of the tool would result in the tool being drawn into the work, gradually increasing the depth of cut.

10.20.4 Chip-breaker

The dangers of continuous chips with their razor sharp jagged edges have already been discussed. Never remove these chips with your bare hands. Always use a chip rake. Stop the machine before removing the swarf. If it catches on the rapidly revolving job it can whip round and cause a serious accident. For the same reason the swarf must not be allowed to build up in the vicinity of the workholding device and the cutting zone. The use of a chip breaker can prevent the formation of dangerously long continuous chips. Figure 10.40(a) shows an inserted tip tool and Fig. 10.40(b) shows the action of the chip-breaker. It curls the chip up so tightly that the chip material becomes work hardened and brittle, resulting in the chip breaking up into small pieces that can be disposed of more easily and safely.

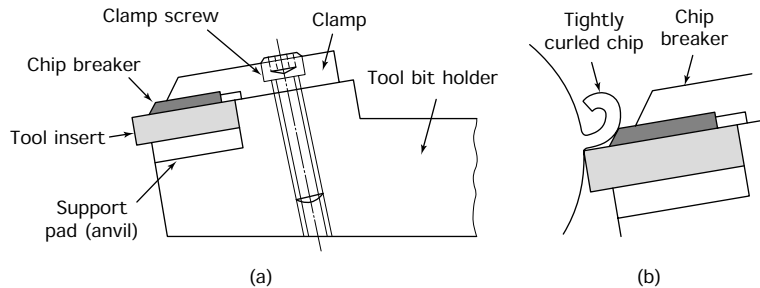


Figure 10.40 *Chip breaker: (a) inserted tip tool with chip breaker; (b) action of chip breaker*

10.21 Cutting lubricants and coolants

Cutting fluids are designed to fulfil one or more of the following functions:

- Cool the tool and the workpiece.
- Lubricate the chip/tool interface and reduce the friction between the chip and the rake face of the tool.
- Prevent chip welding (formation of a built-up edge).
- Improve the surface finish of the workpiece.
- Flush away the chips (swarf).
- Prevent corrosion of the work and the machine.

New compounds and synthetic additives and oils are being developed all the time. It is always best to consult the expert advisory service of the cutting fluid manufacturers. The selection and use of the correct cutting fluid can be the cheapest and most effective way of increasing the productivity of a machine shop. For general purpose machining a soluble oil is usually used.

10.21.1 Soluble oils

When water and oil are added together they refuse to mix but, if an emulsifier in the form of a detergent is added, the oil will break up into droplets and spread throughout the water to form an emulsion. This is what happens when the so-called 'soluble' cutting oils are added to water. The milky appearance of these emulsions is due to the light being refracted by the oil droplets. It is from this milky appearance that the emulsion gets its popular name of 'suds'.

The ratio of oil to water and the procedure for mixing will be recommended by the oil supplier. These conditions must be rigidly observed or

- the emulsion will break down on standing;
- the optimum cooling and lubrication properties of the emulsion will not be achieved.

The dilution of the oil with water greatly reduces the cost, but it also reduces the lubricating properties of the oil. This is why 'suds' are unsuitable for very severe machining operations such as gear cutting and broaching. Further, the high water content tends to cause corrosion of the work and the machine. Therefore, soluble oils should always contain a rust inhibitor.

Note that ordinary mineral oils are unsuitable as metal-cutting lubricants and coolants.

- Their viscosity is too high and their specific heat capacity is too low.
- They cannot withstand the very high pressures that exist between the chip and the tool. They give off noxious fumes when raised to the temperatures that exist in the cutting zone.
- They also represent a fire hazard.

10.22 Tool height

Figure 10.41 shows why it is essential to mount the tool at the centre height of the workpiece.

- Figure 10.41(a) shows the tool correctly set. You can see that the effective cutting angles are the same as those on the tool.
- Figure 10.41(b) shows the tool set below centre. You can see that, although the tool is ground to the same cutting angles, the rake angle

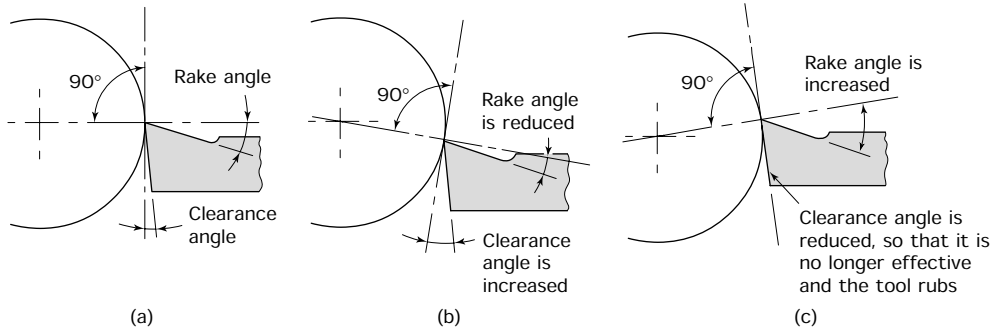


Figure 10.41 Effect of tool height on lathe tool angles: (a) tool set correctly on centre height; (b) tool set below centre height; (c) tool set above centre height

has been effectively reduced and the clearance has been effectively increased.

- Figure 10.41(c) shows the tool set above centre. You can see that once again the tool has been ground to the same cutting angles. This time the setting of the tool causes the rake angle to be effectively increased and the clearance angle to be effectively reduced, causing the tool to rub.

Figure 10.42 shows the effect of tool height on the effective cutting angles of a boring tool. You can see that this time the effects of the tool height on the effective cutting angles are reversed compared with those shown in the previous figure.

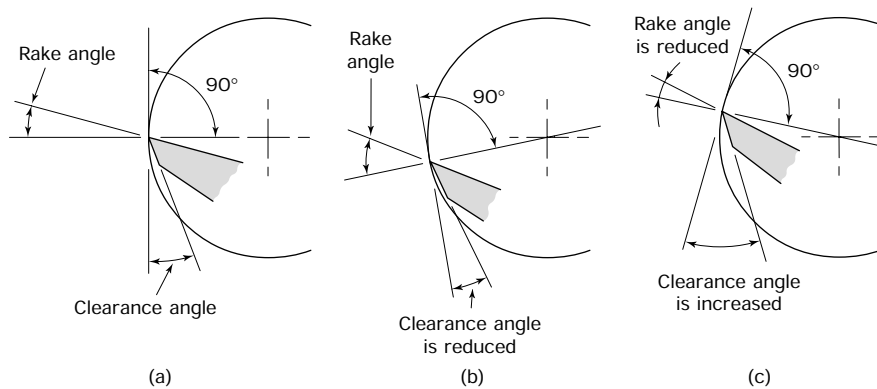


Figure 10.42 Effect of tool height on boring tool angles: (a) tool set correctly on centre height; (b) tool set below centre height; (c) tool set above centre height

The importance of setting a tool to the correct height when facing across the end of a workpiece is shown in Fig. 10.43.

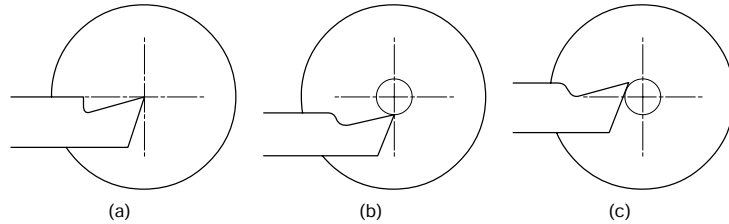


Figure 10.43 *Effect of tool height when facing: (a) tool setting correct – surface will be flat; (b) tool setting low – surface will not be flat; (c) tool setting high – surface will not clean up, and tool will be prevented from reaching centre of bar*

- In Fig. 10.43(a) the tool point is set to the centre height correctly and a smooth surface is produced.
- In Fig. 10.43(b) the tool is set below centre height and this time a ‘pip’ is left at the centre of the work. This is not only unsightly, but would produce difficulties if the end of the work needed to be centre drilled.
- In Fig. 10.43(c) the tool is set above centre height and this time it is impossible to face across the centre of the work.
- The tool can be set to the correct centre height by comparison with the point of the tailstock centre.

10.23 Relationship between depth of cut and feed rates as applied to turning operations

Orthogonal cutting and oblique cutting were introduced earlier in Fig. 10.39. Let’s now investigate these techniques further as applied to parallel and perpendicular turning.

10.23.1 Cylindrical (parallel) turning

Figure 10.44(a) shows a cylindrical turning operation being performed by moving the tool parallel to the axis of the workpiece. Since the cutting edge of the tool is at right angles (perpendicular) to the direction of feed, the tool is said to be cutting orthogonally. The shaded area represents the cross-sectional area (shear area) of the chip. This area is calculated by multiplying the feed per revolution of the workpiece by the depth of cut ($A = f \times d$).

Figure 10.44(b) shows the same turning operation using a tool in which the cutting edge trails the direction of feed. Such a tool is said to be cutting obliquely. The cross-sectional area of the chip produced is the same as when cutting orthogonally since again $A = f \times d$. However, when cutting obliquely, the chip thickness (W) is reduced as shown in Fig. 10.44(c), where it can be seen that:

- The depth of cut d is constant in both examples.
- The feed/rev f is constant in both examples.

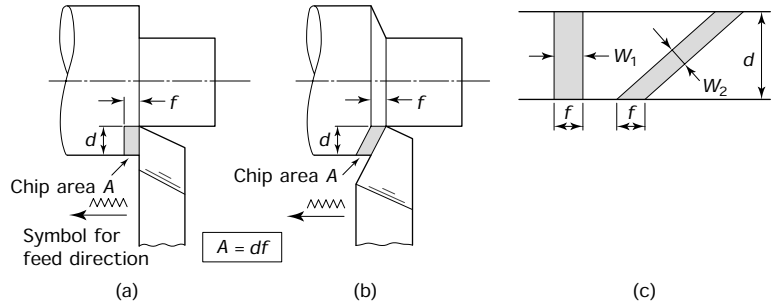


Figure 10.44 Feed and depth of cut for parallel (cylindrical) turning: (a) orthogonal cutting; (b) oblique cutting; (c) chip width – depth of cut d , feed/rev f and chip area A ($A = df$) are constant for both figures; chip thickness W varies – oblique cutting reduces W without reducing A

- The chip area ($A = f \times d$) is constant for both examples (parallelogram theory).
- The chip thickness is less when cutting obliquely because $W_1 > W_2$.

Since the chip is thinner when cutting obliquely the chip is more easily deflected over the rake face of the tool and the force it exerts on the tool is correspondingly less. This reduces wear on the tool and lessens the chance of chip welding without reducing the rate of material removal since the area of the cut is unaltered.

The same area of cut can be achieved using a shallow cut and a high rate of feed or by using a deep cut and a low rate of feed. Figure 10.45(a) shows what happens when a shallow cut at a high rate of feed is chosen. The chip is being bent across its deepest section. This not only requires considerable force, but the high feed rate will lead to a rough finish. In Fig. 10.45(b) a deep cut at a low rate of feed is being used. This time the chip is being bent across its thinnest section.

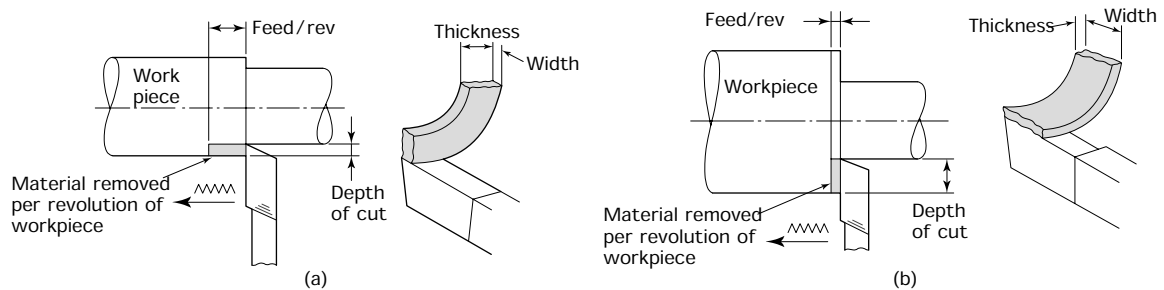


Figure 10.45 Effects of feed rates and depth of cut: (a) coarse feed + shallow cut and effect on chip; (b) fine feed + deep cut and effect on chip

Since the bending force varies as the cube (10^3) of the chip thickness, the force required to bend the chip is greatly reduced. For example,

halving the chip thickness reduces the bending force to one-eighth of its previous value. Unfortunately a deep cut with a shallow feed can lead to chatter and a compromise has to be reached between depth of cut and rate of feed.

10.23.2 Perpendicular turning

Figure 10.46 shows examples of turning when the direction of feed is at right angles (perpendicular) to the axis of the workpiece. A parting-off operation is shown in Fig. 10.46(a), and the tool is cutting orthogonally since the cutting edge of the tool is at right angles to the direction of feed. You may find it strange that the depth of cut is controlled by the width of the tool, but look at it this way – Depth of cut is always at right angles to the direction of feed. Since the feed is perpendicular to the workpiece axis, it follows that the depth of cut must be parallel to the workpiece axis and this is the width of the tool.

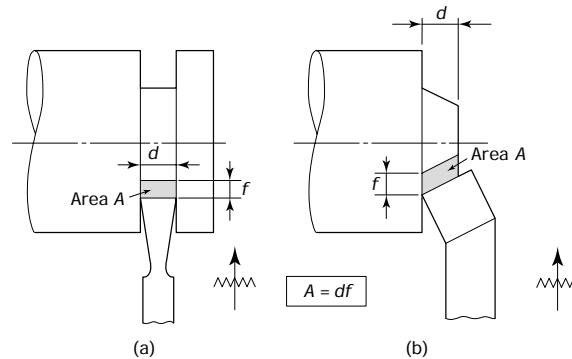


Figure 10.46 Feed and depth of cut for perpendicular turning ($A = df$): (a) orthogonal cutting (grooving and parting off); (b) oblique cutting (surfacing)

A facing operation is shown in Fig. 10.46(b). This time the tool is cutting obliquely since the cutting edge is inclined to the direction of feed. In both examples the area of cut is the depth of cut multiplied by the feed per revolution ($A = d \times f$).

10.23.3 Cutting forces

Figure 10.47(a) shows the main cutting forces acting on a turning tool that is cutting orthogonally. Additional forces are present when the tool is cutting obliquely as shown in Fig. 10.47(b).

- The main cutting force F_c is a reaction force and is equal to but never greater than the downward force of the chip on the tool.
- The feed force F_f is also a reaction force and is caused by the resistance of the material being cut to the penetration of the cutting tool.

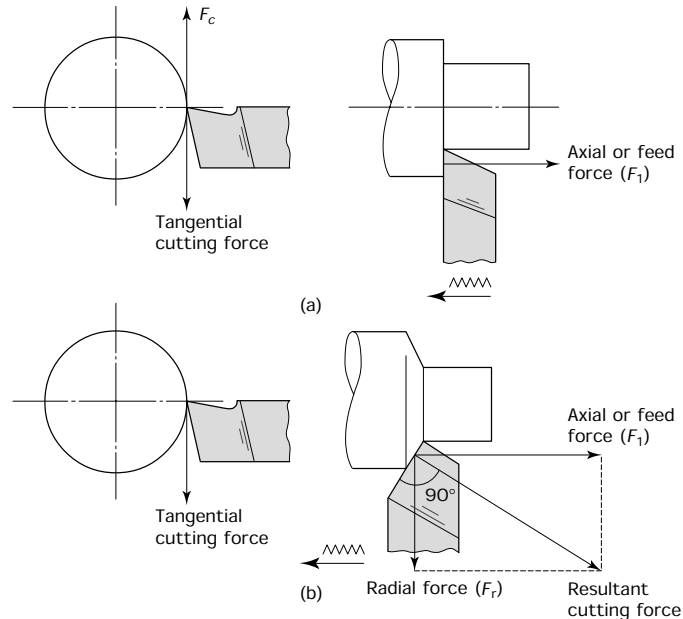


Figure 10.47 Forces acting on turning tools: (a) orthogonal cutting (no radial force on tool); (b) oblique cutting

We call these forces reaction forces because their magnitude depends upon the workpiece material and the cutting conditions. If the lathe is operated without the workpiece in place the tool would not be cutting and there would be no cutting force or feed force acting on the tool and, therefore, no reaction forces would be present. If the workpiece is a relatively weak material such as aluminium then modest cutting and feed forces would be exerted on the cutting tool. If a strong material such as alloy steel is cut with the same depth of cut and rate of feed then the forces acting on the tool would be very much greater. The limiting forces are those which are so great that the tool cannot withstand them and it breaks.

Let's now look at the remaining force. This is the radial force F_r in Fig. 10.47(b). This force exists only when the tool has an oblique cutting action. Figure 10.47(b) shows a roughing tool with a trailing approach angle. The radial force is trying to push the tool away from the work. Therefore, this force keeps the flanks of the cross-slide screw and nut in contact with each other and takes up any backlash due to wear. This prevents the tool being drawn into the work and producing undersize work.

10.24 Cutting speeds as applied to turning operations

To keep the cost of production to a minimum during a machining process, the rate of material removal must be kept as high as possible. It is usual to break down the component by means of a series of roughing cuts,

leaving a small amount of metal on for a finishing cut to produce the finish and dimensional accuracy required. The factors controlling the rate of material removal are:

- Finish required.
- Depth of cut.
- Tool geometry.
- Properties and rigidity of the cutting tool and its mounting.
- Properties and rigidity of the workpiece.
- Rigidity of the work holding device.
- Power and rigidity of the machine tool.

Many of these factors have already been discussed but we still have to consider the cutting speed. Cutting speeds and feed rates depend upon the material being cut, the finish required and the type of tool material being used. Table 10.8 lists some typical values of cutting speeds for high-speed steel tools. These figures are only a guide and they may be

TABLE 10.8 *Cutting speeds and feeds (typical for HSS)*

<i>Material being turned</i>	<i>Feed (mm/rev)</i>	<i>Cutting speed (m/min)</i>
Aluminium	0.2–1.00	70–100
Brass (alpha) (ductile)	0.2–1.00	50–80
Brass (free-cutting)	0.2–1.5	70–100
Bronze (phosphor)	0.2–1.0	35–70
Cast iron (grey)	0.15–0.7	25–40
Copper	0.2–1.00	35–70
Steel (mild)	0.2–1.00	35–50
Steel (medium carbon)	0.15–0.7	30–35
Steel (alloy-high tensile)	0.08–0.3	5–10
Thermosetting plastic*	0.2–1.0	35–50

*Low speed due to abrasive properties.

increased or decreased as experience dictates. Much higher cutting speeds can be used when carbide-tipped tools are employed. When using tipped tools you should consult the manufacturers' literature for information on cutting speeds and feed to ensure that the tools are used efficiently.

Example 10.1 *Calculate the spindle speed, to the nearest rev/min, for turning a 25 mm diameter bar at a cutting speed of 30 m/min (take π as 3.14).*

$$\begin{aligned}
 N &= \frac{1000S}{\pi D} && \text{where: } N = \text{spindle speed} \\
 &= \frac{1000 \times 30}{3.14 \times 25} && S = 30 \text{ m/min} \\
 &= \mathbf{382 \text{ rev/min}} \text{ (to nearest rev/min)} && \pi = 3.14 \\
 &&& D = 25 \text{ mm}
 \end{aligned}$$

Example 10.2 Calculate the time taken to turn a brass component 49 mm diameter by 70 mm long if the cutting speed is 410 m/min and the feed rate is 0.5 mm/rev. Only one cut is taken (take π as 22/7).

$$\begin{aligned}
 N &= \frac{1000S}{\pi D} && \text{where: } N = \text{spindle speed} \\
 &= \frac{1000 \times 44 \times 7}{22 \times 49} && S = 44 \text{ m/min} \\
 &= \mathbf{286 \text{ rev/min}} \text{ (to nearest rev/min)} && \pi = 22/7 \\
 &&& D = 49 \text{ mm}
 \end{aligned}$$

$$\text{Rate of feed (mm/rev)} = 0.5 \text{ mm/rev}$$

$$\begin{aligned}
 \text{Rate of feed (mm/min)} &= 0.5 \text{ mm/rev} \times 286 \text{ rev/min} \\
 &= 143 \text{ mm/min}
 \end{aligned}$$

$$\left. \begin{array}{l} \text{Time in minutes taken} \\ \text{to traverse 70 mm} \end{array} \right\} = \frac{70 \text{ mm}}{143 \text{ mm/min}}$$

$$\left. \begin{array}{l} \text{Time in seconds taken} \\ \text{to traverse 70 mm} \end{array} \right\} = \frac{70 \times 60}{143} = \mathbf{29.37 \text{ seconds}}$$

10.25 The production of some typical turned components

10.25.1 Between centres

It has been stated earlier in this chapter that where two or more diameters are to be strictly concentric they must be turned at the same setting. Figure 10.48 shows a component with a number of concentric diameters. In this example, no matter what method of workholding is employed, it is impossible to turn all the diameters at the same time and at some stage the component has to be turned end for end. Since the component is not hollow it can be held between centres and this will ensure that the diameters turned at the second setting will be concentric with the diameters turned at the first setting.

The sequence of operations for the manufacture of this component is shown in Fig. 10.49. To ensure success it is essential to use a DTI to check that the headstock centre is running true. If it proves impossible to get the centre to run true then a soft centre must be used and turned *in situ*

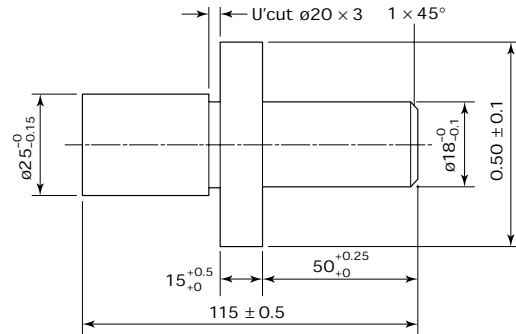


Figure 10.48 Shaft: material free-cutting mild steel $\text{Ø} 50 \times 125$ (dimensions in millimetres)

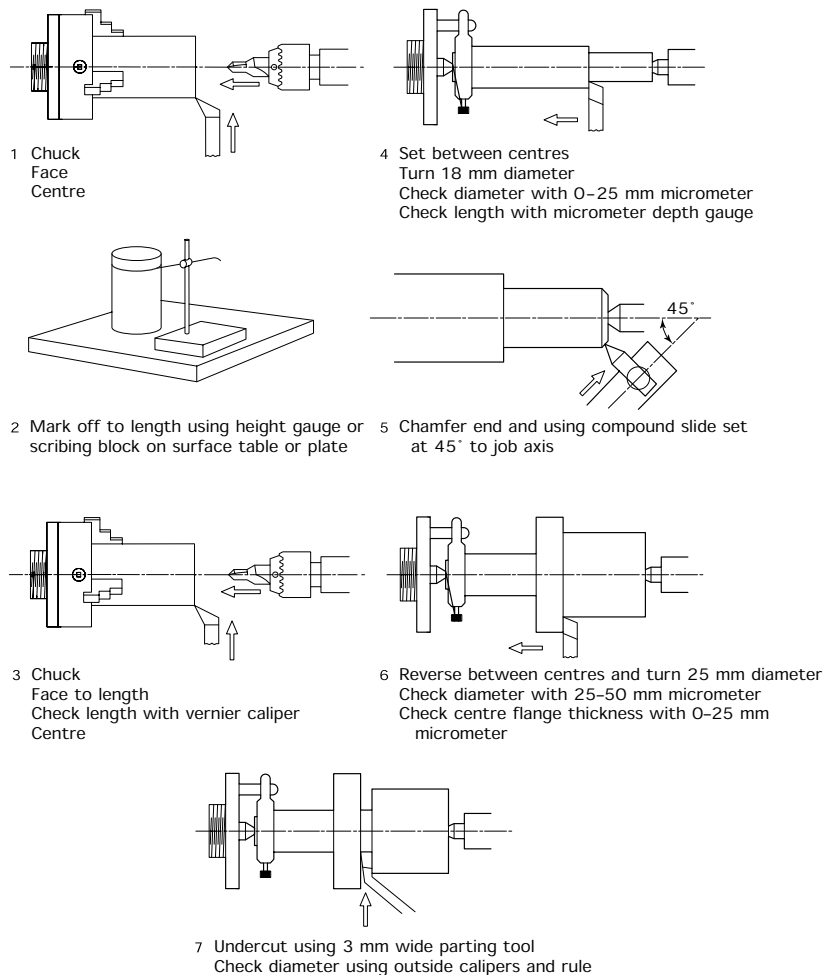


Figure 10.49 Turning shaft between centres

to a conical point of 60° included angle of taper. A trial cut should then be taken along the length of the work to check that the headstock centre and tailstock centre are in alignment and that there is no taper. Any taper should be corrected by lateral adjustment of the tailstock.

10.25.2 Three-jaw, self-centring chuck

The three-jaw, self-centring chuck is the most popular workholding device on the lathe because of its ease and quickness in setting up. However, unless it is used and maintained with care it also gives the *least accurate results*. Figure 10.50 shows a typical component suitable for chuck work.

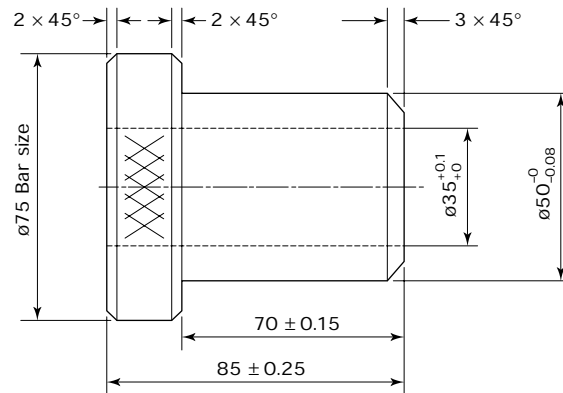


Figure 10.50 *Large bush*

In planning the operations for this component, it should be noted that only the 35 mm diameter and the 50 mm diameter have to be concentric. They must therefore be machined at the same setting. The knurled diameter of the collar does not require a greater degree of concentricity than is readily available with a three-jaw chuck. Therefore only the concentric diameters have to be turned at the same setting. Remember that a drilled hole has only limited accuracy and that it will be necessary to finish the 35 mm diameter by boring to remove any residual errors. Figure 10.51 shows a suitable operation sequence for this component.

10.25.3 Taper mandrel

If the bore of the bush had been too small to bore out with a substantial boring tool or boring bar, then an alternative method of production would be required. For example, after rough turning the external diameter, the hole could be drilled and reamed. The bush could then be pressed onto a taper mandrel and the external diameter finish turned between centres, as discussed earlier in this chapter, to ensure concentricity.

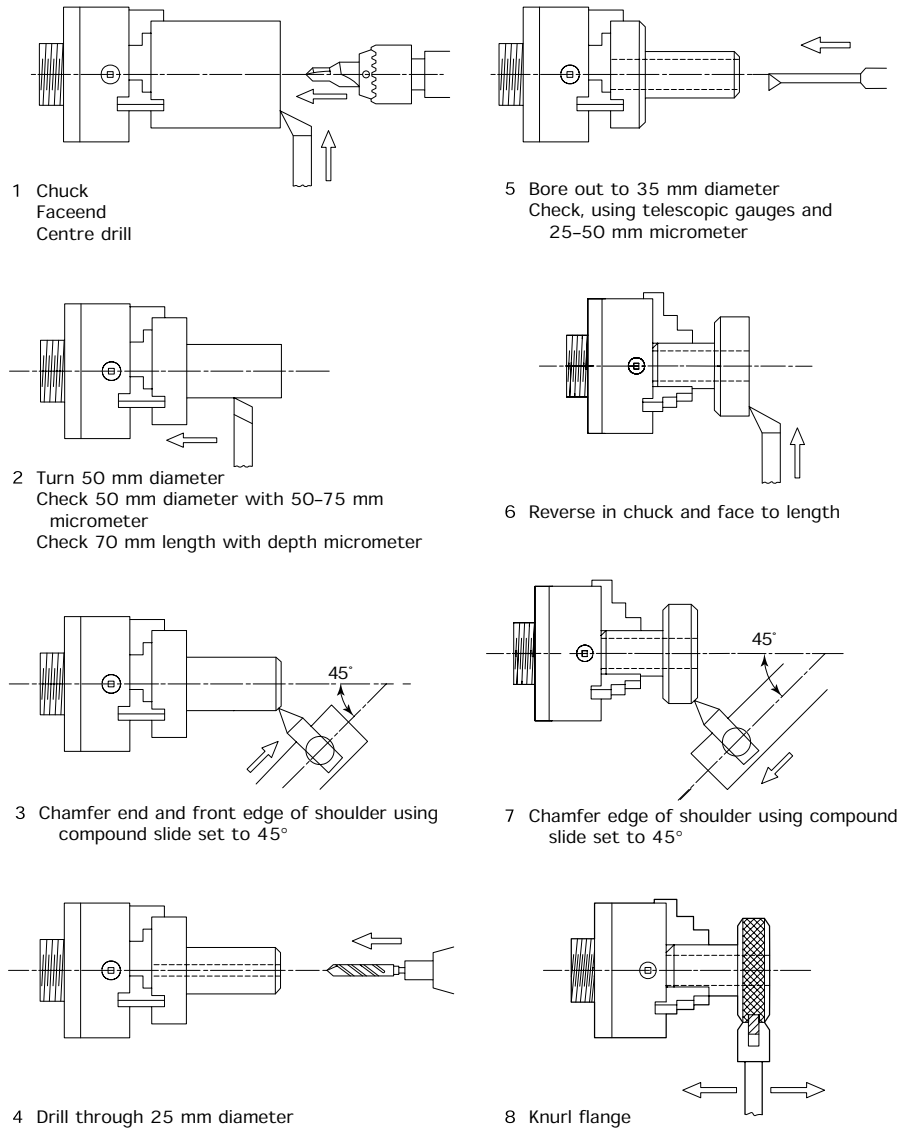


Figure 10.51 *Turning the bush in a self-centring chuck*

10.25.4 Parallel mandrel (snug)

The component shown in Fig. 10.52(a) is too thin to mount on a taper mandrel; however, it can be held on a parallel mandrel or ‘snug’ as shown in Fig. 10.52(b). Should the mandrel have to be reused from time to time, it can be reset in a four-jaw chuck using a DTI as shown in Fig. 10.52(c) to ensure concentricity. This type of mandrel can also be

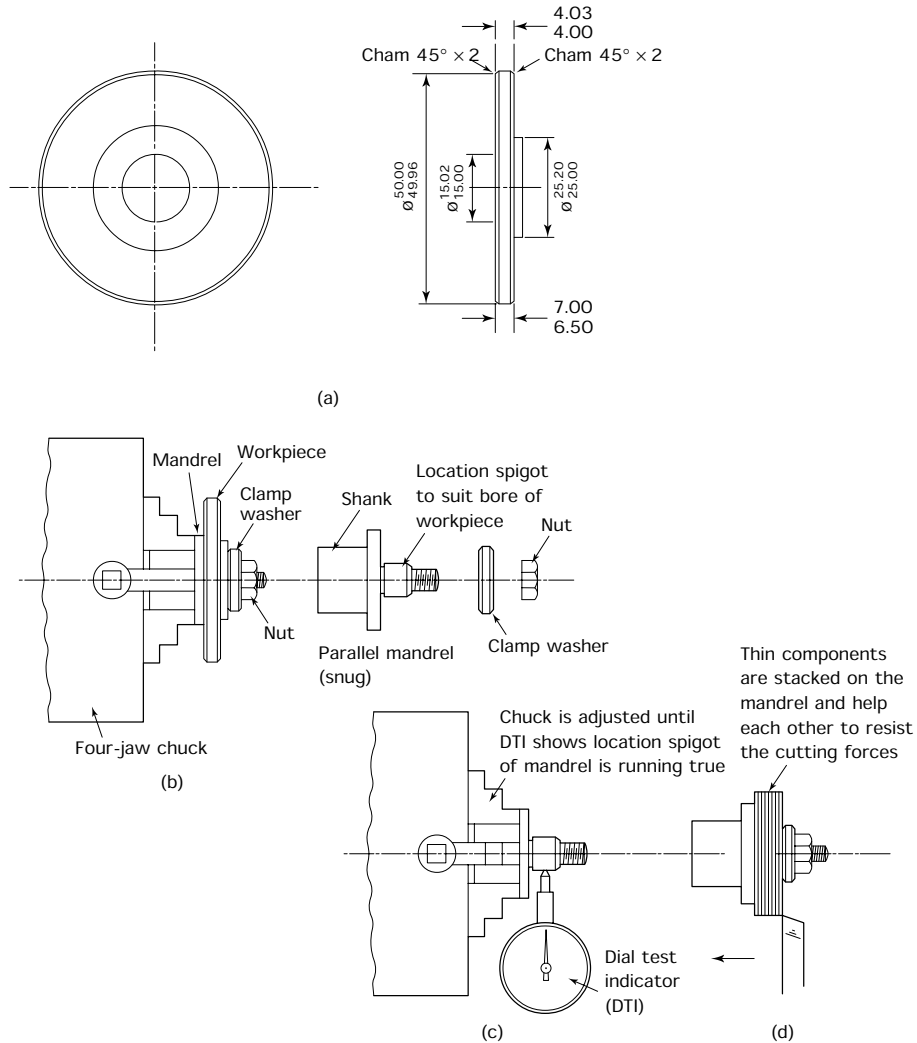


Figure 10.52 Example of parallel mandrel work: (a) 50 mm diameter to be turned concentric with the bore (dimensions in millimetres); (b) use of parallel mandrel; (c) setting the parallel mandrel; (d) use of the parallel mandrel for thin work

used for very thin components. These can be mounted side by side in a batch as shown in Fig. 10.52(d). This not only increases the productivity but the components support each other, so preventing distortion resulting from the cutting forces.

10.25.5 Four-jaw chuck

Figure 10.53(a) shows a component that has to be reversed and reset for the second operations. The initial turning can be done in a three-jaw,

self-centring chuck so that it appears as shown in Fig. 10.53(b). However, when it is reversed for the second operations it has to be held in a four-jaw chuck so that it can be 'clocked up' to run true with a DTI.

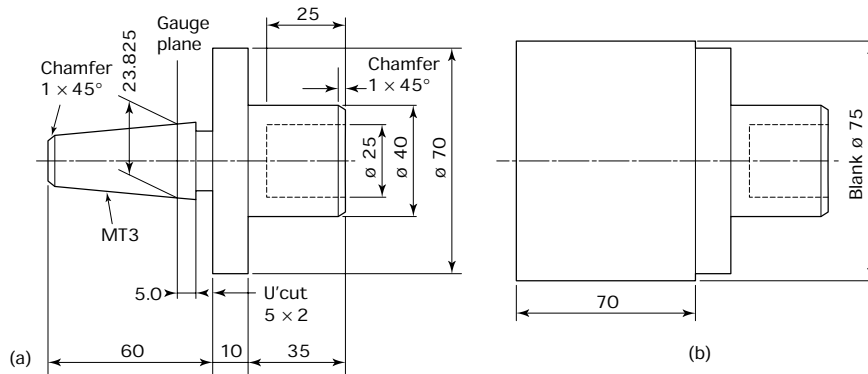


Figure 10.53 Component requiring second operation machining: (a) finished component; (b) component as turned in three-jaw chuck ready for second operation work (dimensions in millimetres)

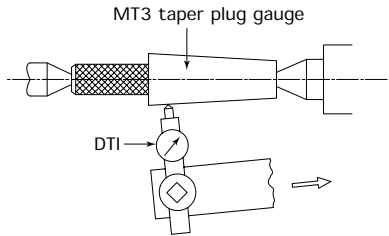
The sequence for the *second operations* to make this component is shown in Fig. 10.54. Had a batch of these components been required, then all the first operations would have been completed in a three-jaw chuck for the entire batch. The three-jaw chuck would then have had its hard jaws replaced by a set of *soft jaws* and these would have been bored out to suit the component as discussed earlier in this chapter. Since the jaws would have been turned to size *in situ*, the work mounted in them would run true without adjustment and without having to 'clock up' each individual component. For a batch of components this saves time over using a four-jaw chuck.

10.25.6 Faceplate

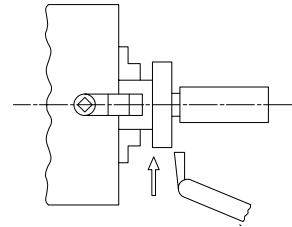
The faceplate is used when the axis of the turned component has to be perpendicular (at right angles) to the datum surface as shown in Fig. 10.55(a). In this example the 50 mm diameter has to be rebored to take a replacement bearing. The new bore has to be concentric with the existing bore and perpendicular to the face AA. The component is lightly clamped to a faceplate and trued up using a DTI as shown in Fig. 10.55(b) by gently tapping the component into position with a soft faced hammer or mallet. It is then clamped tightly to resist the cutting forces and rechecked to ensure it hasn't moved. Finally it is rebored and checked for size.

Exercises 10.1 Safety in the use of machine tools

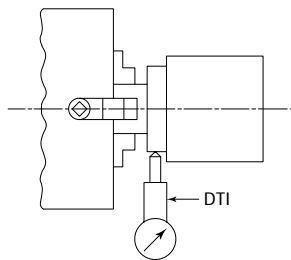
- Describe FIVE important personal safety precautions that should be taken when operating a centre lathe.



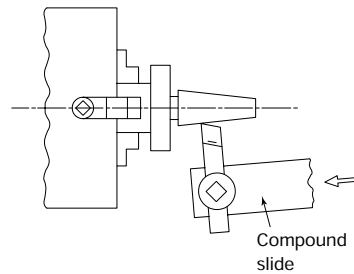
- 1** Set MT3 taper plug gauge between centres
Set over compound slide so that DTI shows a constant reading along the full length of taper
Compound slide is kept at this setting up to and including operation 5



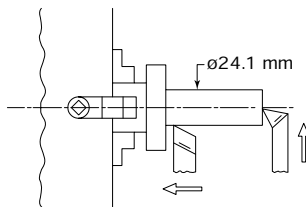
- 4** Undercut using a cranked tool to avoid fouling the flange



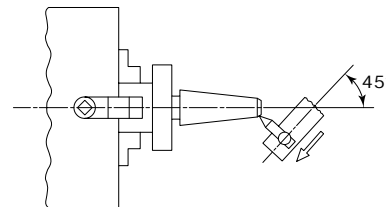
- 2** Remove centres and mount four-jaw chuck
Hold on $\phi 40$ mm in four-jaw chuck
Set to run true using a DTI bearing on the previously turned $\phi 70$ mm



- 5** Turn taper using compound slide.
Remember, this was set to correct angle in operation 1 using a 3MT plug gauge.
Check workpiece taper using a stepped, 3MT ring gauge



- 3** Turn maximum diameter for MT3 taper ($\phi 24.1$ mm) and face to length (60 mm)



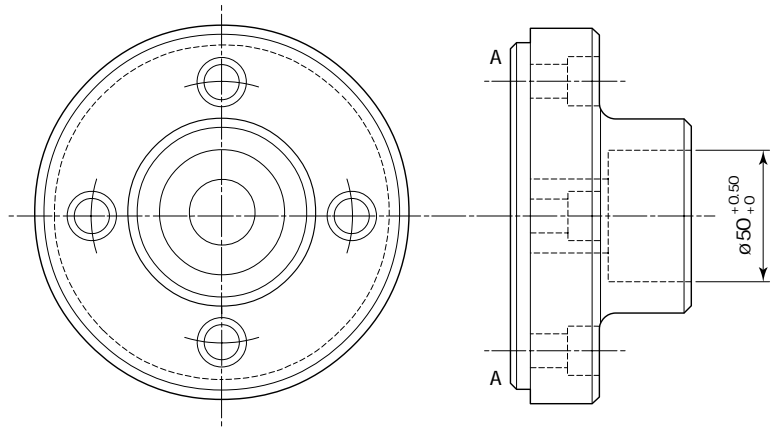
- 6** Reset compound slide to 45° . Chamfer end of taper

Figure 10.54 Operation sequence for component requiring second operation machining

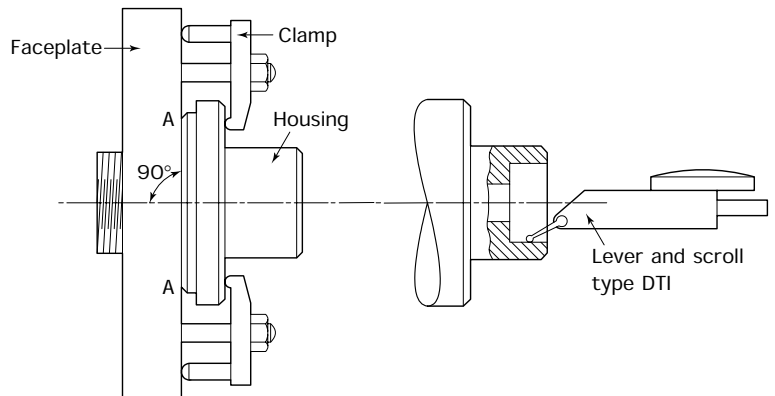
- (b) Name FIVE important safety features that should be provided on all centre lathes.
- (c) Describe five safety rules that should be observed when operating a centre lathe.

10.2 The centre lathe

- (a) Figure 10.56 shows an outline drawing of a centre lathe. Copy the drawing and name the features shown.



(a)



(b)

Figure 10.55 Bearing housing to be rebored (a), method of clamping bearing housing onto a faceplate and setting it to run true (b)

- (b) List the advantages and limitations of a quick change tool post compared with a four-way turret tool post.
- (c) With the aid of sketches, describe how the following surfaces can be generated on a centre lathe.
 - (i) Cylindrical surfaces.
 - (ii) Plane surfaces.
 - (iii) Conical (tapered) surfaces (one method only need be shown).

10.3 Spindle noses

Select and sketch three types of spindle nose and list their relative advantages and limitations. State which one is most likely to be found on a modern industrial lathe.

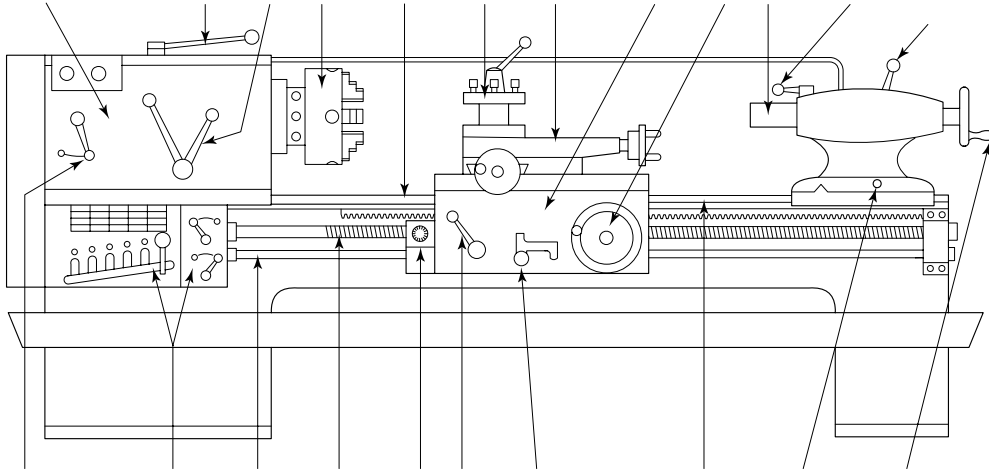


Figure 10.56 *Exercise 10.2(a)*

10.4 Workholding

- (a) When turning between centres, explain why:
 - (i) The headstock centre must be checked for true running.
 - (ii) The tailstock centre must be eased from time to time when using a solid centre.
 - (iii) Work that should be cylindrical may be tapered. Also state how you would check for this inaccuracy and how you would correct it.
 - (iv) Slender work is sometimes the correct size at each end but oversize in the middle (barrel shaped). Explain how you would prevent this happening.
- (b) Work is sometimes held between centres on a taper mandrel. Explain why this is necessary and what precautions you would take to prevent the work becoming loose.
- (c) When holding work in a three-jaw, self-centring chuck:
 - (i) Describe the precautions that should be taken to keep the chuck in good condition and prolong its initial accuracy.
 - (ii) Explain why separate internal and external jaws are required.
 - (iii) Explain why soft jaws may sometimes be used.
- (d) With reference to the four-jaw chuck:
 - (i) List its advantages and limitations compared with a three-jaw, self-centring chuck.
 - (ii) Sketch a component that needs to be made in a four-jaw chuck.

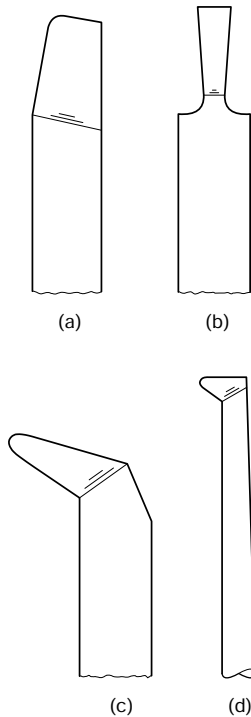


Figure 10.57 Exercise 10.7(a)

- (e) List the advantages and limitations of using collets compared with using a three-jaw chuck.
- (f) Sketch a typical component that needs to be turned on a faceplate rather than in a chuck. Also show how the component would be attached to the faceplate.

10.5 Concentricity and eccentricity

- (a) Explain briefly with the aid of sketches what is meant by the terms:
 - (i) Concentricity.
 - (ii) Eccentricity.
- (b) Explain briefly with the aid of sketches how concentricity between various internal and external diameters can be maintained:
 - (i) When turning from the bar.
 - (ii) When setting for second operation work.

10.6 Miscellaneous operations

- (a) Describe THREE ways of producing holes and bores on a lathe and list the relative advantages and limitations of each of the methods chosen.
- (b)
 - (i) Describe how you would use taps and dies to produce screw threads on a lathe.
 - (ii) Describe the precautions you would take when using taps and dies on a lathe to ensure an accurate thread is produced.
- (c) With the aid of sketches describe ONE method of taper turning and list the advantages and limitations of the method chosen.

10.7 Turning tools and chip formation

- (a) Figure 10.57 shows four typical turning tools. Describe, with the aid of sketches, typical applications for these tools.
- (b) Explain:
 - (i) what is meant by the term continuous chip;
 - (ii) what is meant by the term non-continuous chip;
 - (iii) the conditions under which these different types of chip may be produced;
 - (iv) what a chip-breaker is and why it may be used.
- (c) Explain, with the aid of sketches, how the following tool angles are applied to single point turning tools.
 - (i) Rake angle.
 - (ii) Clearance angle.
 - (iii) Secondary clearance angle (boring tool).
 - (iv) Wedge angle.
 - (v) Plan approach angle.
- (d) Explain, with the aid of sketches:
 - (i) the difference between positive and negative rake cutting as applied to turning tools;

- (ii) the difference between *oblique* and *orthogonal* cutting.
- (e) List the essential requirements of a cutting fluid for general turning operations.
- (f) Describe the precautions that should be taken when mixing and using a soluble cutting fluid.
- (g) List the advantages and disadvantages of using a cutting fluid when turning.
- (h) Calculate the spindle speed, to the nearest rev/min, for turning a 50 mm diameter at a cutting speed of 40 m/min.
- (i) Using the spindle speed calculated in (h) above, calculate the time taken to take a cut 75 mm long at a feed rate of 0.15 mm/rev.

10.8 Turning operations

- (a) Describe with the aid of sketches the production of the component shown in Fig. 10.58. Pay particular attention to the method of workholding. List the tools and equipment used.

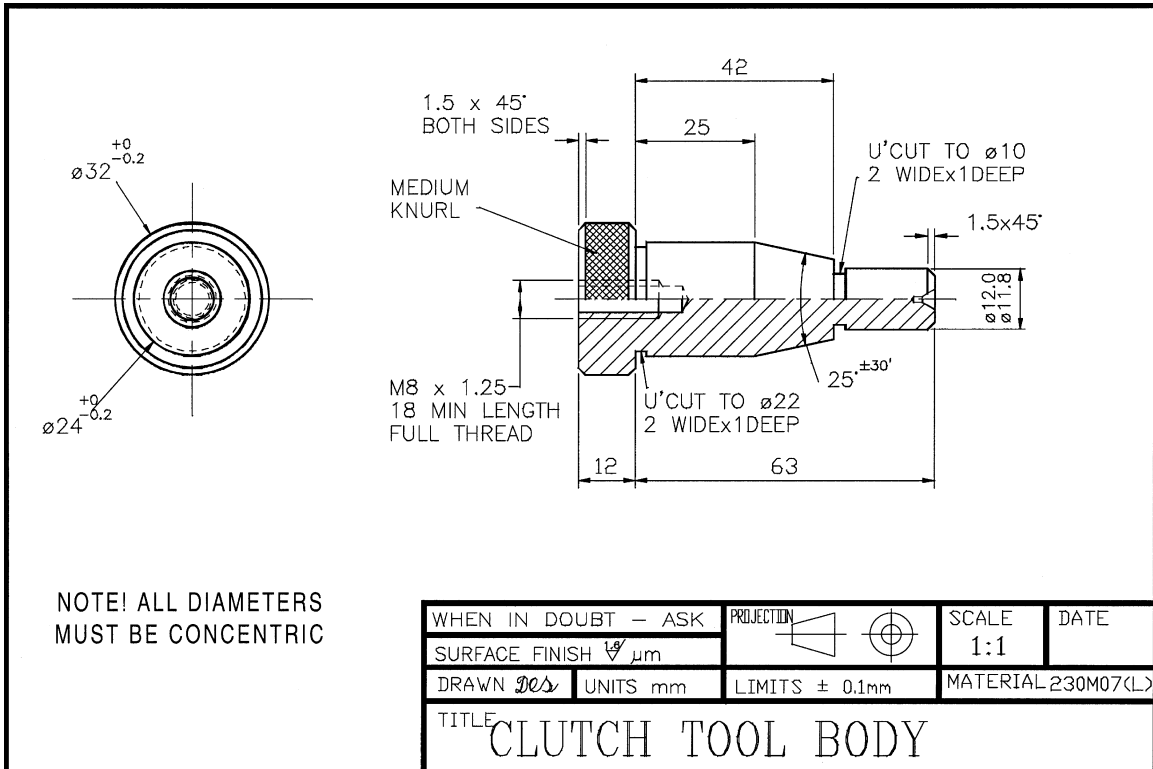


Figure 10.58 Exercise 10.8(a)

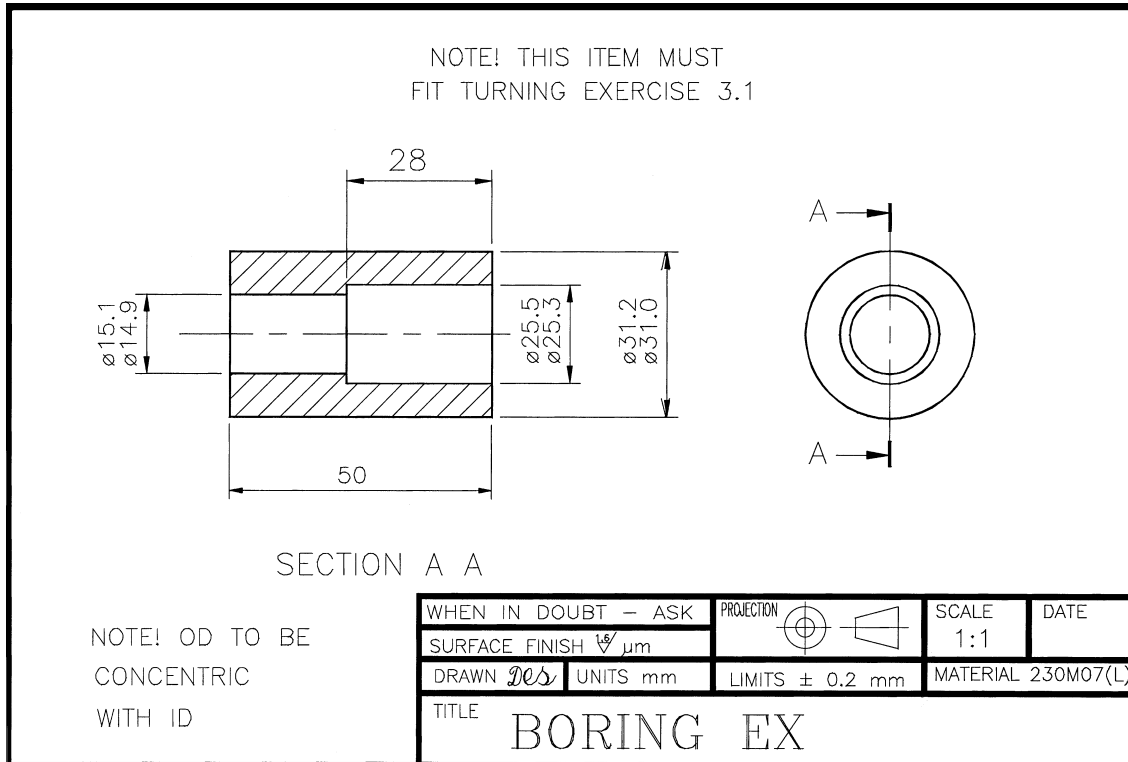


Figure 10.59 Exercise 10.8(b)

- (b) Describe with the aid of sketches the production of the component shown in Fig. 10.59. Pay particular attention to the method of workholding. List the tools and equipment used.

11 Milling machines and milling techniques

When you have read this chapter you should understand:

- How to identify the main features of a typical horizontal milling machine.
- How to identify the main movements of a typical horizontal milling machine.
- How to identify the main features of a typical vertical milling machine.
- How to identify the main movements of a typical vertical milling machine.
- How to select a milling machine appropriate for the work in hand.
- The types of milling cutters that are available and their applications.
- How to select suitable cutters and how to check for defects.
- The correct methods of mounting and holding milling cutters.
- The available methods of workholding and setting.
- How to use milling machines to produce vertical, horizontal and angular faces and slots.

11.1 Safety

Milling machines are classified as *especially dangerous machines*. In addition to the normal requirements of the Health and Safety at Work Act, these machines are also subject to the Horizontal Milling Machine Regulations. Copies of these Regulations are available in the form of a wall chart which is supposed to be hung up near to where such machines are being used.

The main danger associated with milling machines is the cutter. Therefore:

- Make sure the cutter guard is in place before starting the machine.
- Do not remove swarf with a brush whilst the cutter is revolving.
- Do not wipe away coolant from the cutting zone with a rag whilst the cutter is revolving.
- Do not take measurements whilst the cutter is revolving.
- Do not load or unload work whilst the cutter is revolving.

- Do not put your hands anywhere near the cutter whilst it is revolving.

Figure 11.1(a) shows a typical cutter guard as used by skilled operators in toolrooms, prototype workshops and jobbing workshops where the machine is being frequently reset.

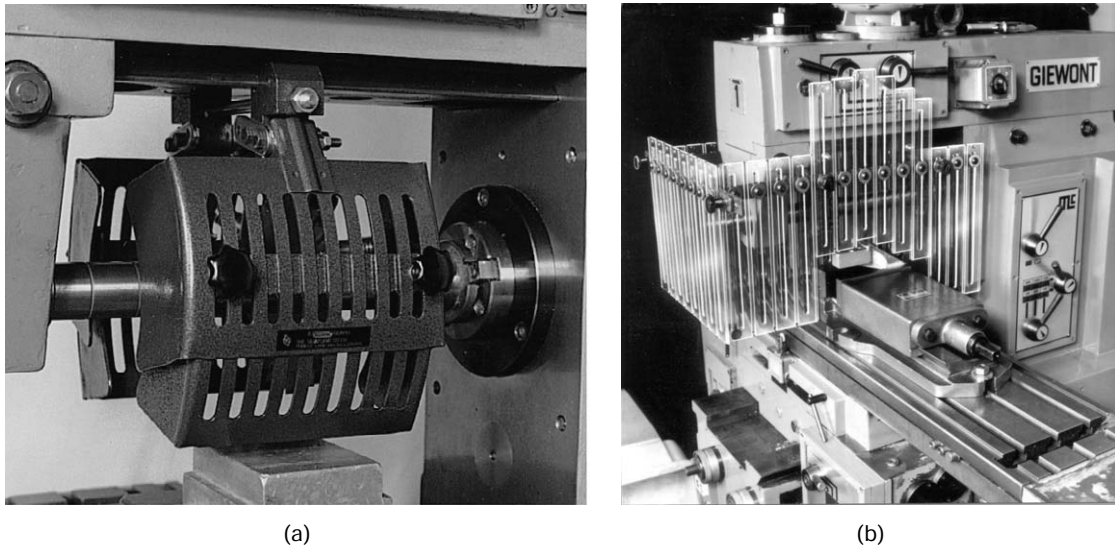


Figure 11.1 *Milling machine guards: (a) toolroom type cutter guard; (b) production type cutter guard*

Figure 11.1(b) shows a production type guard suitable where only semi-skilled labour is employed to operate the machine. The whole of the cutting zone is guarded and loading and unloading of the workholding fixture takes place safely outside the guard.

11.2 The milling process

Milling machines are used to produce parallel, perpendicular and inclined plain surfaces using multi-tooth cutters. These cutters are rotated by the machine spindle, and it is from the plane in which the axis of the spindle lies that determines the name of the machine. The geometry of a single point cutting tool as considered in the previous chapters is shown in Fig. 11.2(a), whilst Fig. 11.2(b) shows how these angles are applied to a milling cutter tooth. The additional secondary clearance angle prevents the heel of the tooth catching on the workpiece as the tool rotates. It also provides chip clearance. Figure 11.2(c) shows an actual milling cutter. Because of the large number of teeth used, the surface produced is virtually a plain surface free from ripples. The surface can be improved even further by cutting the teeth with a helix angle as shown in Fig. 11.2(d)

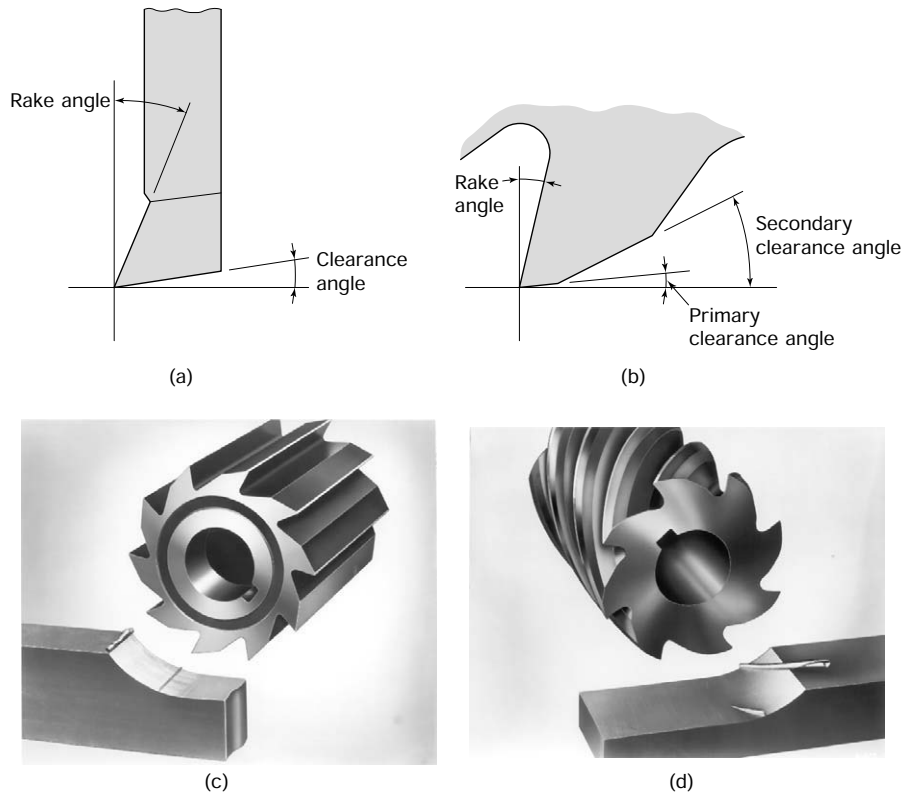


Figure 11.2 Milling cutter tooth angles: comparison of cutter angles for a single point cutting tool (a) and a milling cutter tooth (b); (c) orthogonal cutting (straight tooth) cutter; (d) oblique cutting (30° helical tooth cutter) (photographs reproduced courtesy of Cincinatti Milacron Ltd)

instead of straight across the cutter. This also evens out the forces acting on the machine transmission system since one tooth is starting to cut before the previous tool has finished cutting.

As for turning, modern practice favours the use of carbide-tipped milling cutters for production milling where high rates of material removal are required or when high strength materials are being machined. These can have brazed-on tips as shown in Fig. 11.3(a) or inserted, disposable tips as shown in Fig. 11.3(b). Nowadays, cutters with disposable carbide and coated carbide tips are widely used on production and even for the prototype machining of high strength, hard and abrasive materials.

It would appear from the above comments that the more teeth a cutter has got, the better will be the finish and the faster the cutter will be able to remove metal. This is true only up to a point. For any cutter of a given circumference, increasing the number of teeth reduces the space between the teeth. This makes the teeth smaller and weaker and it also reduces the room for the chips so that the teeth tend to clog easily and break.

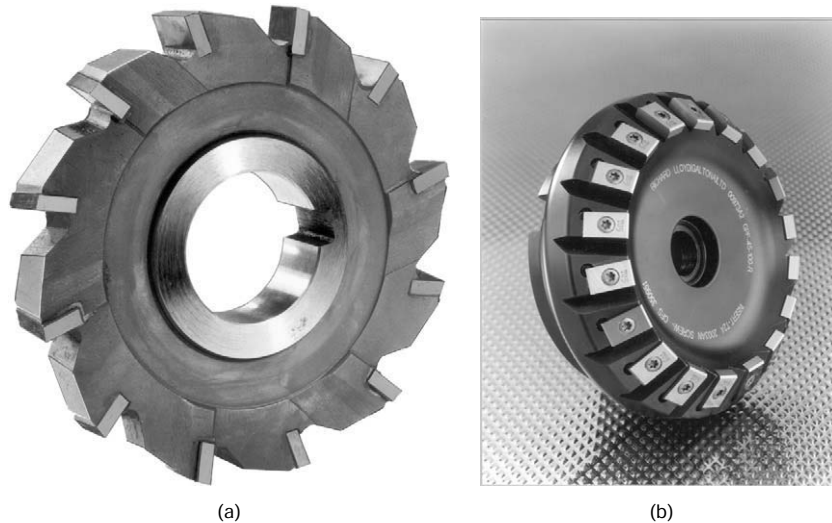


Figure 11.3 Carbide-tipped milling cutters: (a) brazed tip cutter; (b) inserted disposable tip cutter (reproduced courtesy of Richard Lloyd (Galtona) Ltd)

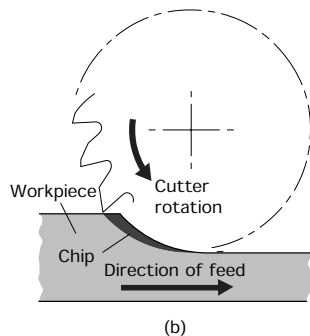
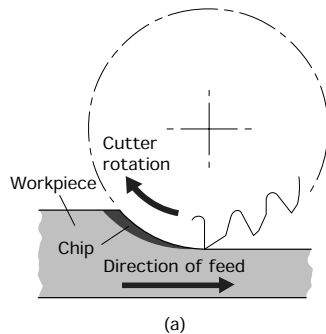


Figure 11.4 Chip formation when milling: (a) up-cut milling; (b) down-cut milling

When choosing a milling cutter for a particular job, the spacing (pitch) of the teeth should be kept as wide as possible for a given class of work in order to provide adequate strength and chip clearance. Thus coarse pitch cutters should be used for roughing out robust work as they have more efficient material removal characteristics and are more economical in the cutting power required. Finer pitch cutters should be used with light cuts where fragile work is involved and a fine finish is required.

11.2.1 Up-cut or conventional milling

This is shown in Fig. 11.4(a). You can see that the work is fed towards the cutter against the direction of rotation.

- This prevents the work being dragged into the cutter if there is any backlash in the feed mechanism.
- Unfortunately this technique causes the cutting edges to rub as each tooth starts to cut and this can lead to chatter and blunting of the cutting edge.
- The cutting action tends to lift the work off the machine table.
- For safety this is the technique you should always adopt unless your instructor advises you to the contrary because he or she knows that your machine is equipped to operate safely using the following technique.

11.2.2 Down-cut or climb milling

This is shown in Fig. 11.4(b). Here you can see that the work is fed into the cutter in the same direction as the cutter is rotating.

Safety: *The climb milling technique can be used only on machines fitted with a 'backlash eliminator' and which are designed for this technique. If it can be used safely this technique has a number of advantages, particularly for heavy cutting operations.*

- The cutter does not rub as each tooth starts to cut. This reduces the risk of chatter and prolongs the cutter life.
- The cutting forces keep the workpiece pressed down against the machine table.
- The action of the cutter helps to feed the work forward and takes most of the load off the feed mechanism.

11.3 The horizontal spindle milling machine

The *horizontal milling machine* gets its name from the fact that the axis of the spindle of the machine, and therefore the axis of the arbor supporting the cutter, lies in a horizontal plane as shown in Fig. 11.5. The more important features and controls are also named in this figure.

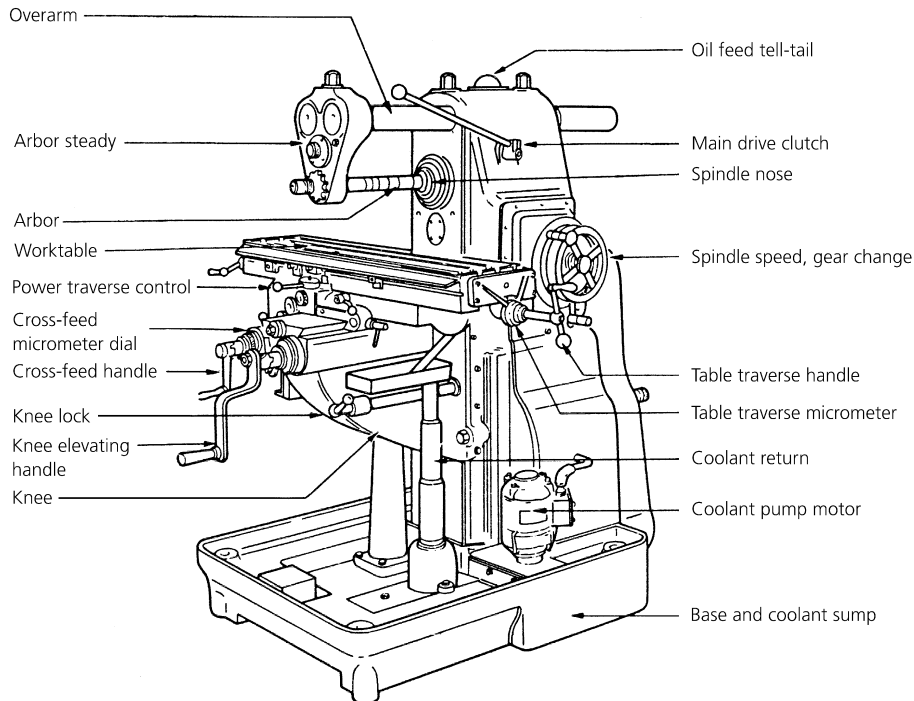


Figure 11.5 *Horizontal spindle milling machine*

11.3.1 Basic movements and alignments of a horizontal spindle milling machine

The basic alignments and movements of a horizontal milling machine are shown in Fig. 11.6. The most important alignment is that the spindle axis, and therefore the arbor axis, is parallel to the surface of the worktable. The depth of cut is controlled by raising the knee and table subassembly. The position of the cut is controlled by the cross-slide and the feed is provided by a lead screw and nut fitted to the table and separately driven to the spindle. Unlike the feed of a lathe which is directly related to the spindle speed and measured in mm/rev, the feed of a milling machine table is independent of the spindle speed and is measured in mm/min.

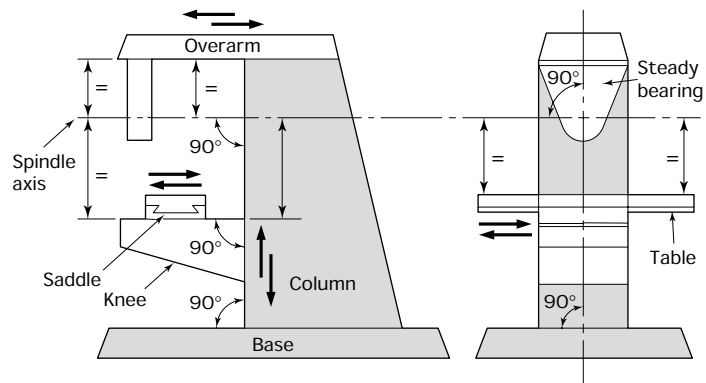


Figure 11.6 Horizontal spindle milling machine: movements and alignments

The horizontal milling machine can produce surfaces that are parallel to the worktable as shown in Fig. 11.7(a). It can also produce surfaces that are perpendicular to the worktable as shown in Fig. 11.7(b). The use of a side and face is shown in Fig. 11.7(c). It can be seen that for this latter cutter the depth of cut is limited by the relative diameters of the cutter and the arbor spacing collars.

11.4 The vertical spindle milling machine

The *vertical milling machine* gets its name from the fact that the axis of the spindle of the machine, and therefore the axis of the cutter being used, lies in the vertical plane as shown in Fig. 11.8. The more important features and controls are also named in this figure.

11.4.1 Basic movements and alignments of a vertical spindle milling machine

The basic alignments and movements of a vertical milling machine are shown in Fig. 11.9. The most important alignment is that the spindle axis, and therefore the cutter axis, is perpendicular to the surface of the

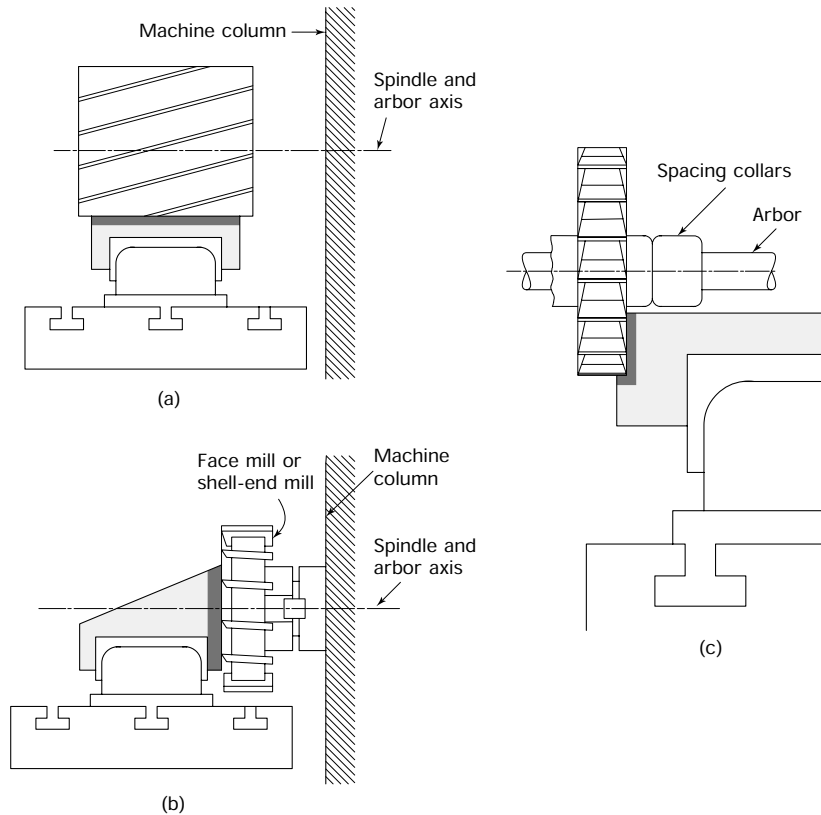


Figure 11.7 Surfaces parallel and perpendicular to the worktable (horizontal milling machine): (a) use of a slab mill to machine a surface parallel to the milling machine table; (b) use of a face mill or a shell-end mill to machine a surface perpendicular to the milling machine table; (c) use of a side and face milling cutter to machine a surface perpendicular to the milling machine table – the depth of the perpendicular surface is limited by the relative diameters of the cutter and spacing collars

worktable. The depth of cut is controlled by raising the knee and table subassembly or, for some operations raising or lowering the spindle. For maximum rigidity, the spindle is normally raised as far as possible. The position of the cut is controlled by the cross-slide and the feed is provided by a lead screw and nut fitted to the table and separately driven to the spindle. As for horizontal milling, the feed of a vertical milling machine table is independent of spindle and is measured in mm/min.

Vertical milling machines produce surfaces parallel to the worktable by means of face milling cutters mounted directly on the spindle end as shown in Fig. 11.10(a). Compared with the rate of metal removal that can be removed with a slab or roller mill on a horizontal machine, larger surfaces can be covered in one pass at greater rates of material removal with a face mill on a vertical spindle machine. Surfaces perpendicular to the worktable are produced by the side of an end milling cutter as shown

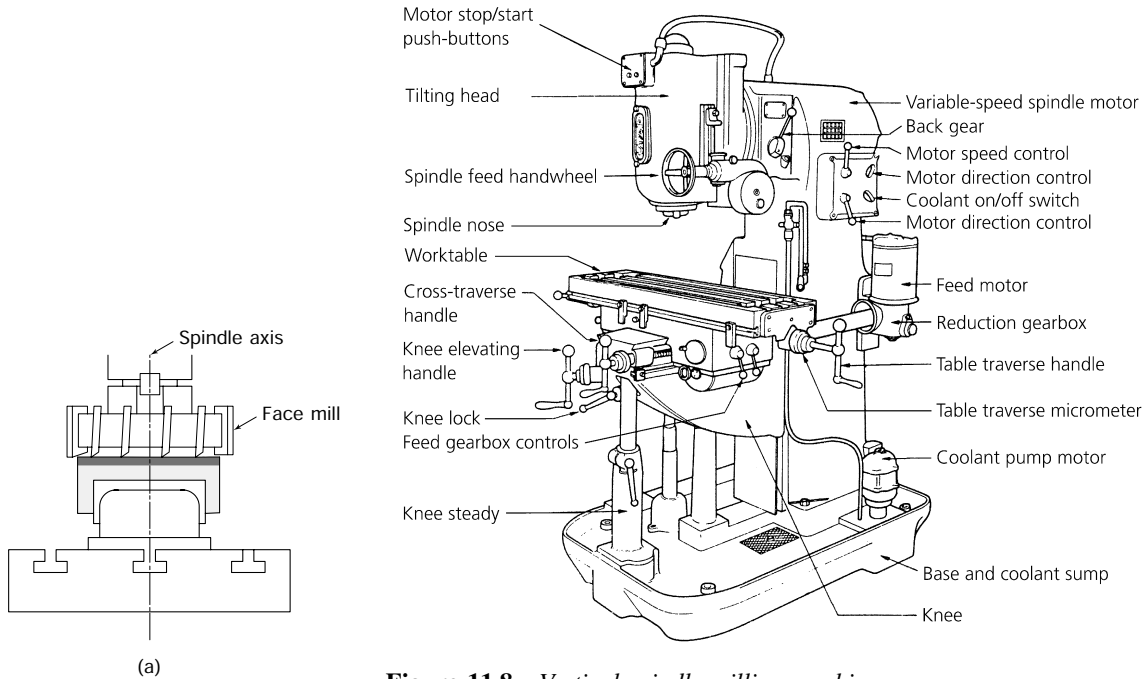


Figure 11.8 Vertical spindle milling machine

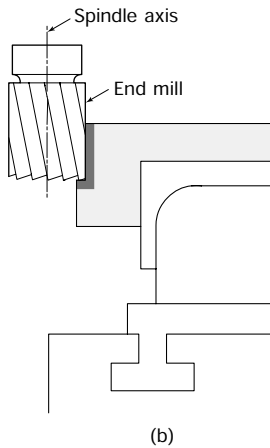


Figure 11.10 Surfaces parallel and perpendicular to the worktable (vertical milling machine): (a) use of a face mill to machine surfaces parallel to the worktable; (b) use of an end mill to machine surfaces perpendicular to the machine table

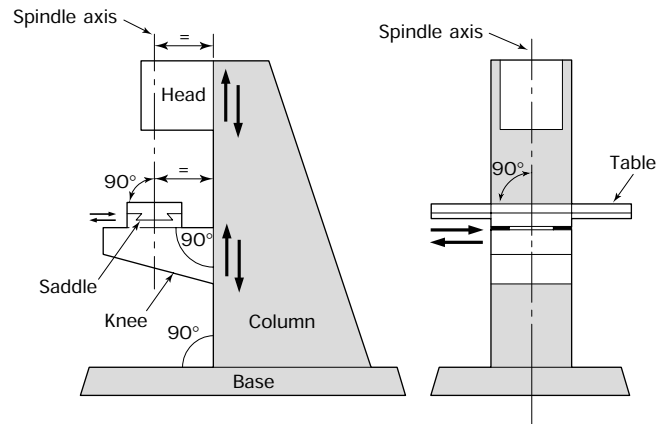


Figure 11.9 Vertical spindle milling machine: movements and alignments

in Fig. 11.10(b). Since the cutter is supported as a cantilever by its shank alone, the load that can be put on it is limited and only relatively low rates of material removal can be removed in this way.

11.5 Types of milling cutters and their applications

Although side and face milling cutters and slab (roller) milling cutters are usually associated with horizontal milling machines, and end mills, slot drills and facing cutters are normally associated with vertical milling machines, any cutter can be used with either machine given a suitable toolholding device. For the time being, however, we will consider the cutters and the surfaces that they produce in conjunction with the machine with which they are most usually associated.

11.5.1 Horizontal milling machine cutters

Figure 11.11 shows some different shapes of milling cutter and the surfaces that they produce. When choosing a milling cutter you will have to specify:

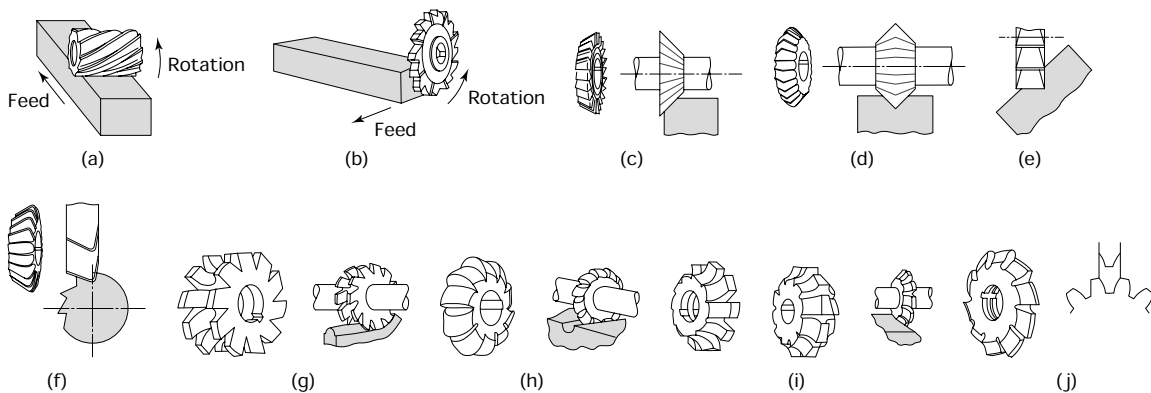


Figure 11.11 Horizontal milling machine cutters and the surfaces they produce: (a) slab milling cutter (cylinder mill); (b) side and face cutter; (c) single-angle cutter; (d) double equal-angle cutter; (e) cutting a V-slot with a side and face mill; (f) double unequal-angle cutter; (g) concave cutter; (h) convex cutter; (i) single and double corner rounding cutters; (j) involute gear tooth cutter

- The bore of this must suit the arbor on which the cutter is to be mounted. In many workshops one size of arbor will be standard on all machines and all the cutters will have the appropriate bores.
- The diameter of the cutter.
- The width of the cutter to suit the work in hand.
- The shape of the cutter.
- The tooth formation.

11.5.2 Vertical milling machine cutters

A selection of milling cutters suitable for a vertical milling machine is shown in Fig. 11.12 and some typical applications are shown in Fig. 11.13. Note that only *slot drills* can be used for making pocket cuts

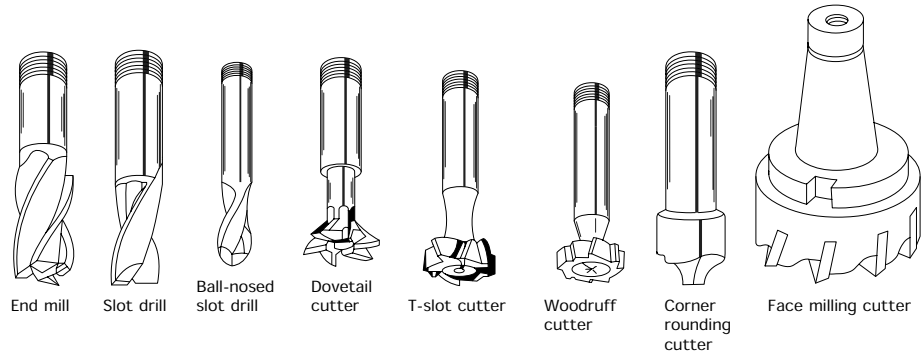


Figure 11.12 Typical milling cutters for vertical spindle milling machines

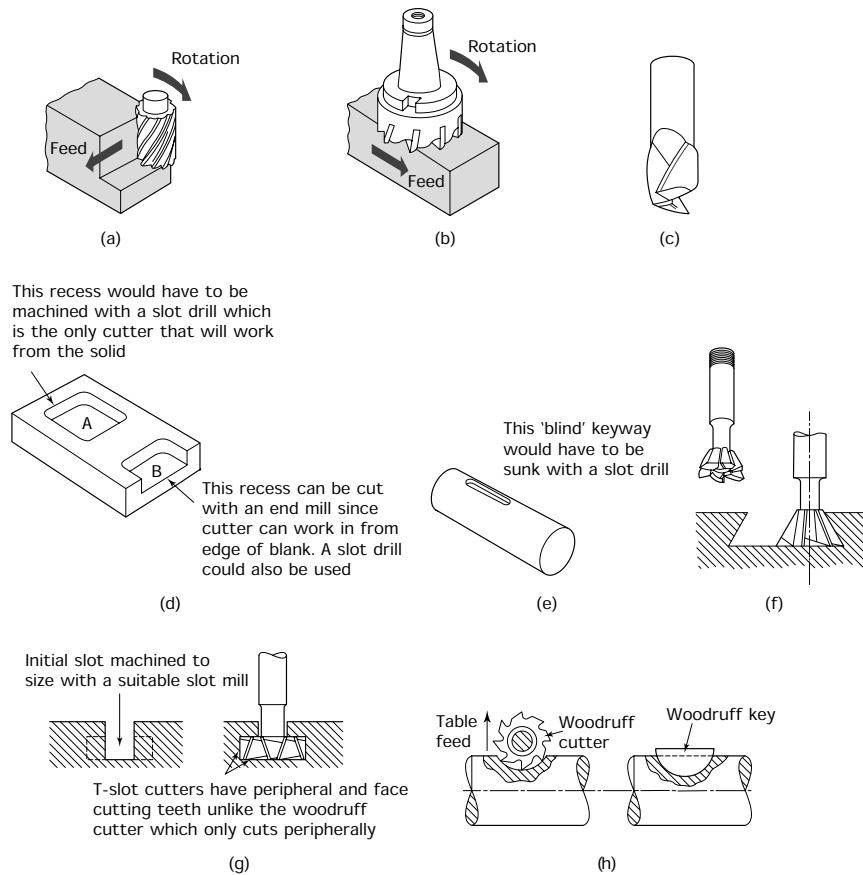


Figure 11.13 Vertical milling machine cutters and the surfaces they produce: (a) end milling cutter; (b) face milling cutter; (c) slot drill; (d) recess A would need to be cut with a slot drill because it is the only cutter that will work from the centre of a solid; recess B could be cut using a slot drill or an end mill because it occurs at the edge of the solid; (e) this blind keyway would have to be sunk with a slot drill; (f) dovetail (angle) cutter; (g) T-slot cutter; (h) Woodruff cutter

from the solid. All the other cutters have to be fed into the workpiece from its side as they cannot be fed vertically downwards into the work.

When choosing a cutter you will need to specify:

- The diameter of the cutter.
- The length of the cutter.
- The type of cutter.
- The type of shank. Some cutters have solid shanks integral with the cutter for holding in a chuck, whilst other cutters are made for mounting on a separate stub arbor. Some large face milling cutters are designed to bolt directly onto the spindle nose of the machine.

11.6 Cutter mounting (horizontal milling machine)

Safety: Make sure the machine is electrically isolated before attempting to remove or mount arbors and cutters.

11.6.1 Long arbor

For most milling operations on horizontal spindle milling machines the cutters are mounted on a long arbor as shown in Fig. 11.14(a). One end of the arbor has a taper for locating in the spindle nose of the milling machine. It also has a slotted flange that registers with the driving dogs on the spindle nose. This arrangement provides a positive drive to the

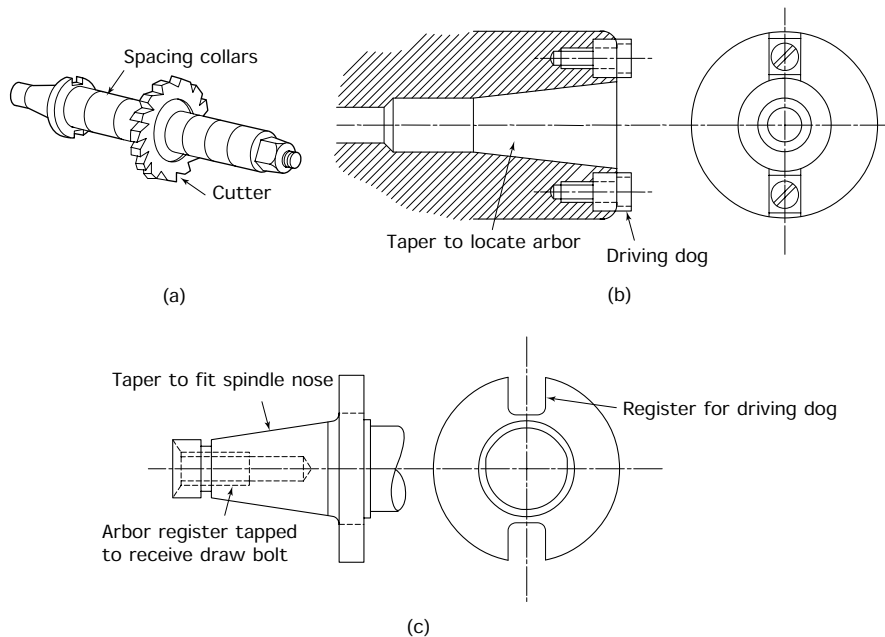


Figure 11.14 Horizontal milling machine arbor: (a) long arbor for horizontal milling machine; (b) milling machine spindle nose; (c) taper register of arbor to fit spindle nose

arbor and no slip is possible. Details of the spindle nose are shown in Fig. 11.14(b) and details of the taper on the arbor end are shown in Fig. 11.14(c). The taper of a milling machine spindle nose is not self-holding like the morse taper of a drill shank. Milling machine arbors have to be held in place by a threaded drawbar that passes through the whole length of the spindle. Tightening the drawbar into the end of the arbor pulls it tightly into the spindle nose.

The outer end of the arbor is supported in a *steady*. The steady itself is supported by the milling machine *overarm* as shown in Fig. 11.15. The forces acting on a milling cutter when it is removing metal rapidly are very great. Therefore the cutter arbor must be adequately supported and the cutter correctly positioned to avoid inaccuracies, chatter and, at worst, a bent arbor. In Fig. 11.15(a) the cutter is incorrectly mounted. There is excessive overhang from the points of support.

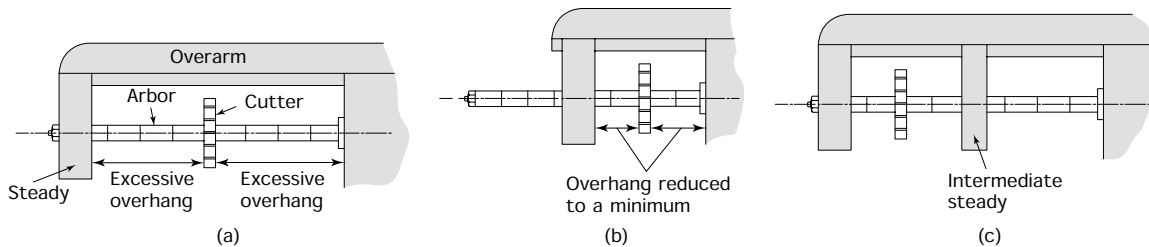


Figure 11.15 Correct use of overarm steady: (a) bad mounting; (b) and (c) good mounting

In Fig. 11.15(b) the overarm and steady bearing have been repositioned to provide support as close to the cutter as possible. Also the cutter itself has been mounted as close to the spindle nose as possible. Thus any overhang has been reduced to a minimum and the cutter is supported with the maximum rigidity.

Sometimes the shape and size of the work prevents the cutter being mounted close to the spindle nose. Figure 11.15(c) shows how an additional, intermediate steady can be positioned on the overarm to support the arbor immediately behind the cutter. This again reduces the overhang to a minimum.

11.6.2 Mounting cutters on a long arbor

The following description assumes that the machine has been left in a clean condition without a cutter on the arbor but with the spacing collars in position on the arbor and the locknut only finger tight to prevent it and the collars from getting lost.

- Remove the locknut from the spindle end and slide the bearing bush and the spacers off the arbor.
- Carefully clean the arbor and check for scoring or other damage. Report any such damage to your instructor/supervisor. In severe cases of damage the arbor may have to be replaced.

- Estimate by eye the position of the cutter from the size and shape of the work and the position of the cut and slide as many collars onto the shaft as are needed to ensure the cutter will be in the correct position.
- Inspect the cutter for blunt cutting edges, chipped teeth and damage to the bore. If these or any other defects are found, return the cutter to the stores to be exchanged for one in good condition.
- Clean the sides of the cutter and its bore and slide this onto the arbor as shown in Fig. 11.16(a). Milling cutter teeth are very sharp, particularly at the corners. Protect your hands by wearing leather gloves or holding the cutter in a thick cloth wiper.

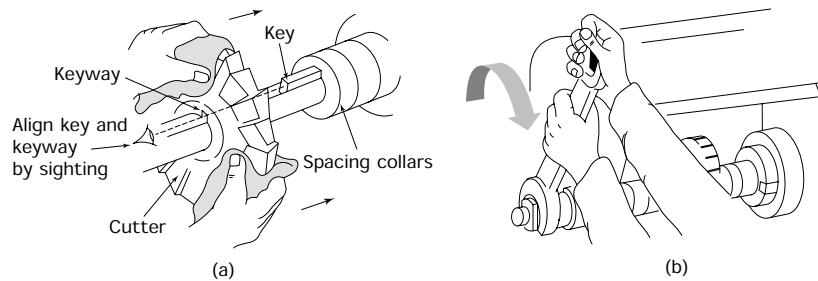


Figure 11.16 *Mounting a cutter on a long arbor: (a) keying the cutter to the arbor – length of key is greater than the width of the cutter, any portion of the key that extends beyond the cutter is ‘lost’ in the spacing collars which also have keyways cut in them; (b) tightening the arbor nut – the steady must be in position when tightening or loosening the arbor nut to prevent bending the arbor*

- Insert a key into the keyway of the arbor to drive the cutter. This prevents the cutter slipping and scoring the arbor. Also, if the cutter stops rotating whilst the table feed is engaged, the arbor will be bent. Although you will see people not bothering with a key, so that they just rely on friction to drive the cutter; this is not good practice for the reasons already mentioned.
- Slide additional spacing collars onto the arbor as required to bring the bearing bush in line with the steady bearing. These spacing collars should be kept to a minimum to avoid excessive overhang and to ensure maximum rigidity as previously mentioned.
- Position the overarm and the steady bearing as shown in Fig. 11.16(b) and tighten their clamping nuts.
- It is now safe to tighten the arbor locknut. This must be tightened or loosened only with the steady in position. This prevents the leverage of the spanner bending the arbor.
- Set the machine to a moderate speed and start it up. Out-of-true running can result from a warped cutter, incorrect grinding and lack of cleanliness in mounting the cutter. If it runs out of true, switch off the machine, remove the cutter, check for cleanliness and remount.
- If the cutter still runs out, seek the assistance of your instructor.

11.6.3 Straddle and gang milling

These techniques are more associated with production milling than with toolroom and prototype work. However, since they are associated with the use of horizontal milling machines they are included here.

Straddle milling

Straddle milling is used to machine two sides of a component at the same time as shown in Fig. 11.17(a). Solid spacing collars are used to take up most of the space between the cutters and an adjustable collar is used for the final adjustment.

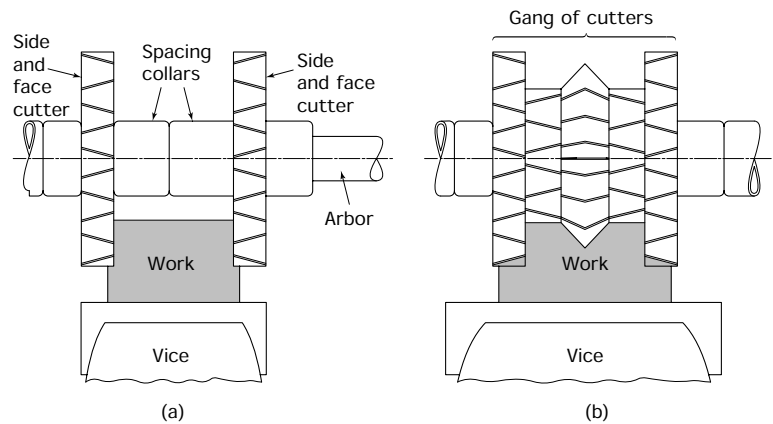


Figure 11.17 Straddle and gang milling: (a) straddle milling; (b) gang milling

Gang milling

Gang milling is even more ambitious and involves milling all the sides and faces of the component at the same time as shown in Fig. 11.17(b). To maintain the correct relationships between the cutters, they are kept together as a set on a spare mandrel and are all reground together when they become blunt.

11.7 Cutter mounting (vertical milling machine)

Safety: Make sure the machine is electrically isolated before attempting to remove or mount arbors and cutters.

11.7.1 Stub arbor

Figure 11.18(a) shows an 'exploded' view of a stub arbor and a shell end milling cutter. The cutter is located on a cylindrical spigot and is driven positively by dogs. It is retained in position by a recessed bolt. To

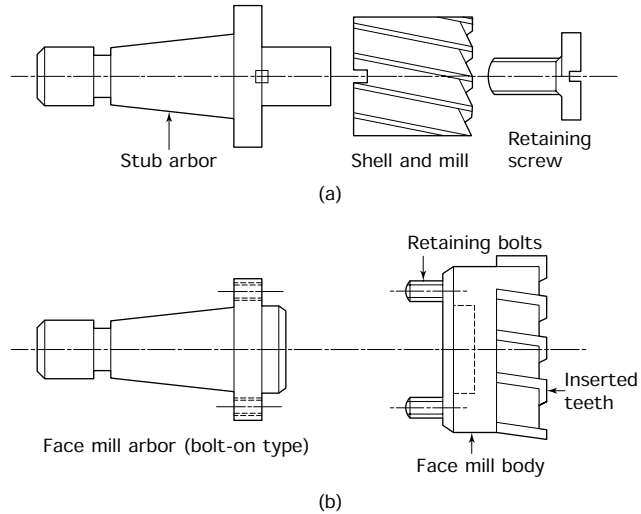


Figure 11.18 Use of stub arbors: (a) shell end mill; (b) face mill

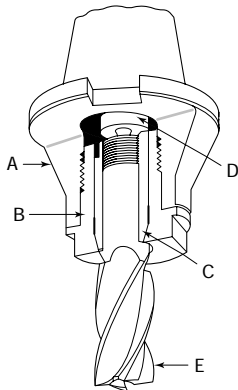


Figure 11.20 Collet chuck for screwed-shank solid end mills: **A** – main body of collet chuck; the locking sleeve **B** positions the collet **C** and mates with the taper nose of the collet to close the collet on the cutter shank; the collet is internally threaded to prevent the cutter **E** being drawn out of the chuck whilst cutting; the male centre **D** anchors the shank end of the cutter and ensures true running

maintain the correct fit, the spigot and register must be kept clean and the cutter must be tightened onto the arbor so that there is no movement between the cutter and the arbor during cutting. Figure 11.18(b) shows a small face mill and its arbor. In both cases the arbor is located in the taper bore of the spindle nose and it is retained in position by the threaded drawbar that passes through the length of the machine spindle. *Note:* Stub arbors and their associated cutters can also be used on horizontal spindle milling machines.

Another type of stub arbor is shown in Fig. 11.19. This allows the cutters normally associated with a horizontal milling machine to be used on a vertical spindle milling machine. Because the stub arbor is supported only at one end, it is not as rigid as the horizontal milling machine arbor and this restricts the size of the cutter that can be used and the rate of metal removal that can be employed.

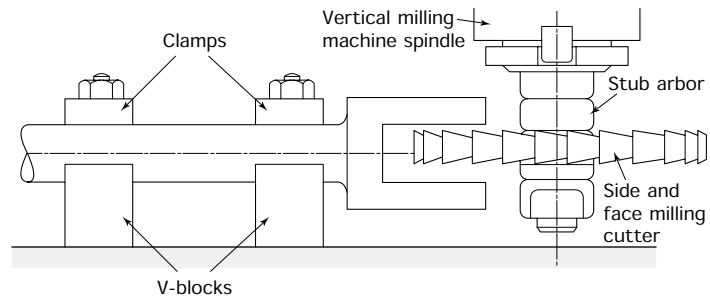


Figure 11.19 Stub arbor for use with cutters normally associated with horizontal milling machines

11.7.2 Collet chuck

Basically a collet is a hardened and tempered steel sleeve with a parallel bore on the inside and a tapered nose on the outside. It is slit at regular intervals around its circumference so that it can close onto the shank of the cutter when the outer sleeve is tightened. Concentric tapers are used to ensure true running and to compensate for wear. Figure 11.20 shows a section through a typical collet chuck.

- The shank of the cutter has a threaded portion at its end that screws into the rear end of the collet. This prevents the forces acting on the flutes of a cutter with positive rake from drawing the cutter out of the collet.
 - The hardened and ground conical centre serves to locate the rear of the cutter and also to act as an end stop and prevents the cutter and the collet being pushed up into the chuck body.
-

11.8 Workholding

The work to be machined on a milling machine may be held:

- In a machine vice.
- Clamped directly onto the machine table.
- Clamped to an angle plate that is itself clamped to the machine table.
- In a milling fixture for production work. To save time pneumatic clamping is often employed.

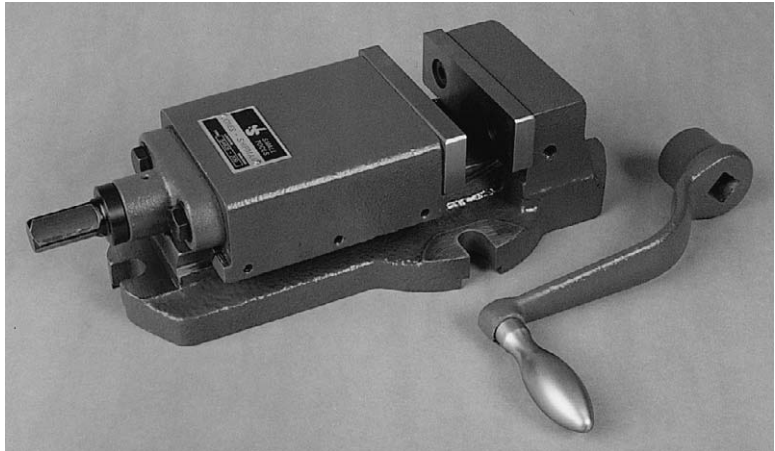
In this chapter only the first two methods will be considered.

11.8.1 Machine vice (plain)

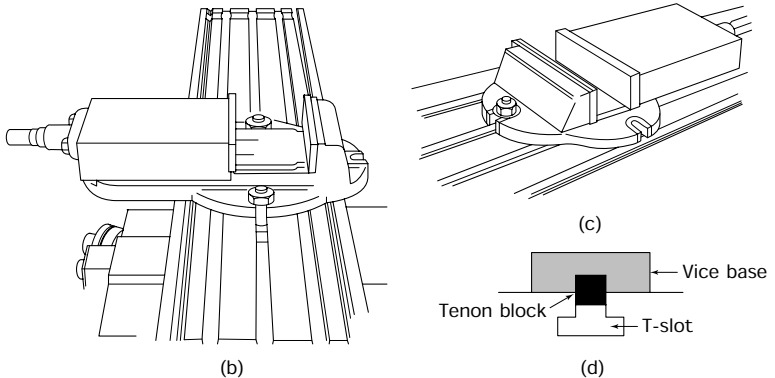
Figure 11.21(a) shows a plain machine vice. It has two sets of fixing holes so that it can be set with its jaws either parallel to the travel of the machine table as shown in Fig. 11.21(b), or it can be set with its jaws perpendicular to the travel of the machine table as shown in Fig. 11.21(c). To facilitate setting, the underside of the vice body has slots machined in it both parallel and perpendicular to the fixed jaw. *Tenon blocks* can be secured into these slots. The tenon blocks stand proud of the slots so that they also locate in the T-slots of the machine table as shown in Fig. 11.21(d).

To maintain positional accuracy of the vice:

- Check the tenons are a close slide fit in the tenon slots in the vice body and also in the T-slots of the machine table.
- Check that the tenons are clean and free from burrs and bruises.
- Clean the tenon slots and insert the tenon blocks, securing them with socket head cap screws.



(a)



(b)

(c)

Vice base
Tenon block
T-slot

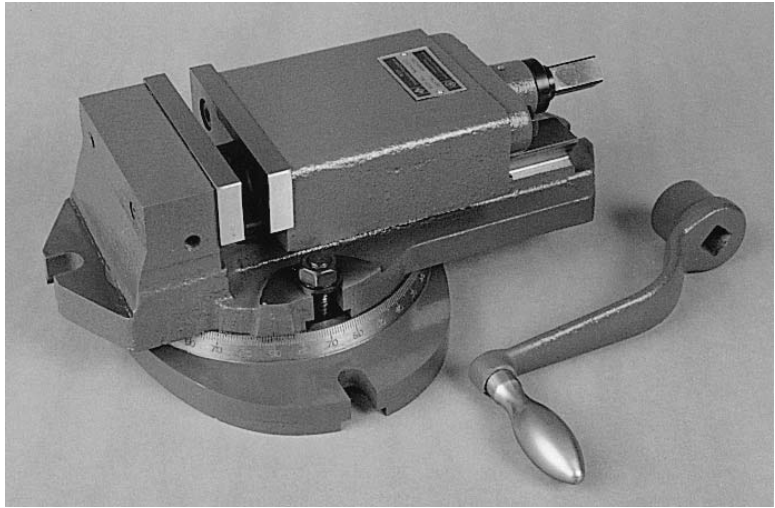
(d)

Figure 11.21 *Mounting and setting a plain machine vice: (a) plain machine vice; (b) vice set with jaws parallel to T-slots; (c) vice set with jaws perpendicular to T-slots; (d) use of tenon block to align vice with the T-slots*

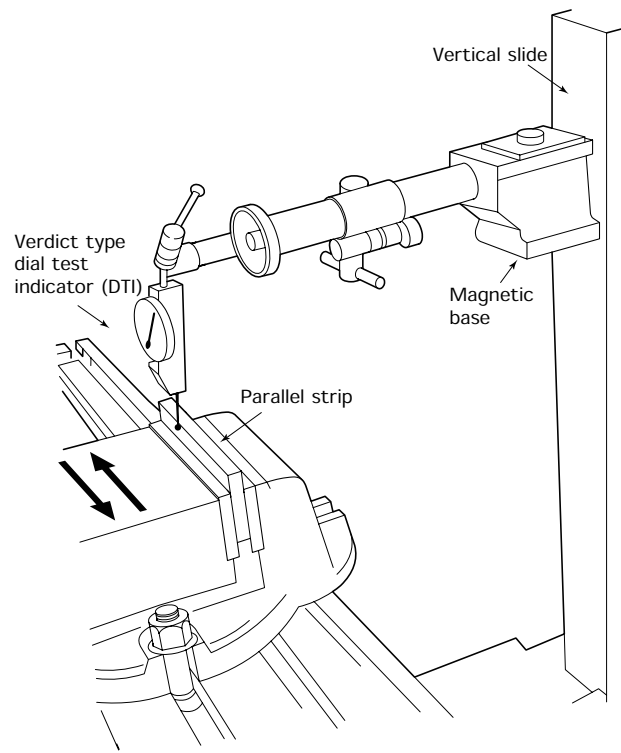
- Check that the T-slots in the machine table are clean and free from burrs and bruises.
- Lower the vice carefully onto the machine table and locate the tenons in the appropriate T-slot.
- Secure the vice to the machine table with suitable T-bolts. Ordinary hexagon bolts should not be used as their heads do not fit properly and they can work loose.
- The vice should now be ready to hold the work.

11.8.2 Machine vice (swivel base)

If the machine vice has a swivel base as shown in Fig. 11.22(a), or it is a plain vice without tenons, then it will have to be set either parallel or



(a)



(b)

Figure 11.22 Setting swivel base machine vices and plain vices without tenons: (a) swivel base machine vice; (b) setting a machine vice

perpendicular to the worktable with the dial test indicator (DTI) as shown in Fig. 11.22(b).

11.8.3 Direct mounting

Work that is too large to hold in a vice or is of inconvenient shape can be clamped directly to the machine table as shown in Figs 11.23(a) and 11.23(b). Sometimes the shape of the casting or forging is such that a jack or wedge is required to level the work ready for cutting. The example shown in Fig. 11.23(c) shows that the opposite end to the clamp is supported on a packing piece. There will, of course, be clamps at both ends of the workpiece. Sometimes castings are slightly warped but not sufficiently to allow the use of jacks and wedges. Thin packing and pieces of shim steel should be inserted under the casting to remove any 'rock' and to provide support under the casting where clamps are to be used. Tightening clamps down onto an unsupported part of the casting could cause it to crack.

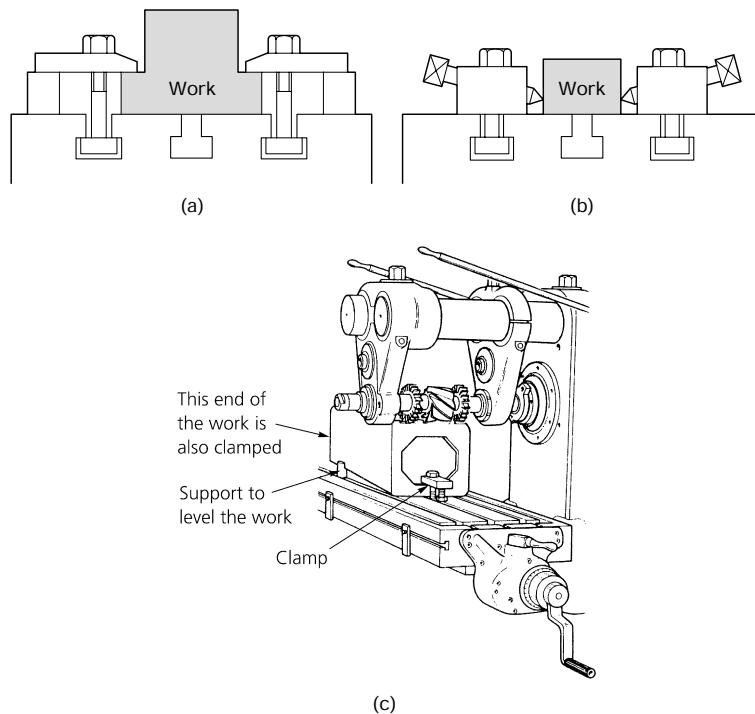


Figure 11.23 Holding larger work: (a) use of clamps; (b) use of table dogs; (c) levelling work

Angle plates as described in Section 7.3.2 can also be used for locating and supporting work on the milling machine table.

11.8.4 Dividing head (simple indexing)

Sometimes you will need to make a series of cuts around the periphery of a component; for example, when cutting splines on a shaft or teeth on a gear wheel. Such an operation requires the work to be rotated through a given angle between each cut. This rotation of the work through given angles between the cuts is called indexing. Figure 11.24 shows a *simple (direct) dividing head*. The index plate locates the spindle of the head directly without any intermediate gearing. In the example shown there are only two rows of holes for clarity. In practice there would be many more rows to give a bigger range of possible spacings.

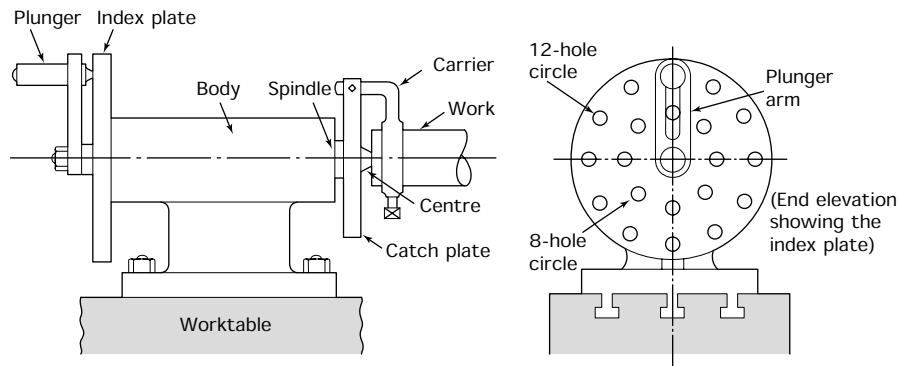


Figure 11.24 *Simple dividing head*

For example, we can index through 120° between the cuts so as to give us three equally spaced slots. We would use the 12 hole circle in the index plate since this is divisible by three, and we would move the plunger arm through a distance of four holes between the cutting of each slot.

If we had wanted four slots we have a choice, we could have rotated the work through three holes in the 12 hole circle between each cut, or we can rotate the work through two holes in the eight hole circle. The result would be the same. Figure 11.25(a) shows a typical component where three equally spaced slots are to be cut.

- The blank would be turned and bored to size ready for milling.
- The blank would then be mounted on a mandrel and supported between the dividing head and its tailstock as shown in Fig. 11.25(b).
- The work is centred under the cutter and cutting takes place.
- For rigidity, cutting should take place towards the diving head and towards the 'plus' end of the mandrel so that the blank cannot work loose.
- You can either complete each slot before indexing to the next one, or you can index from slot to slot for each increase in the depth of cut so that all the slots are finished together.

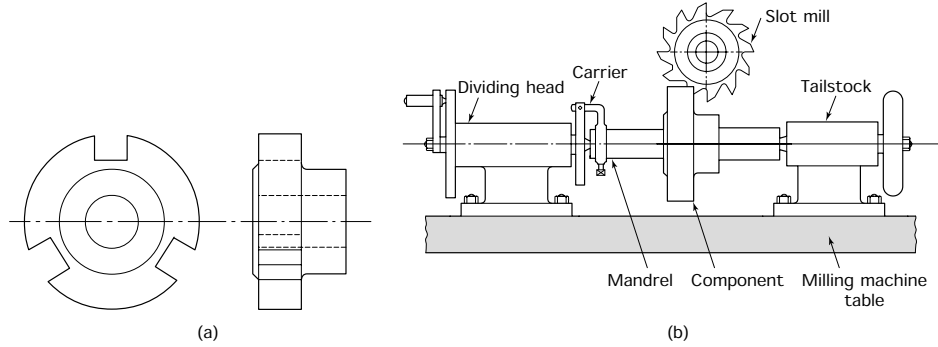


Figure 11.25 Example of simple indexing: (a) component requiring indexing; (b) set-up for simple indexing

- For holding some components a three-jaw or a four-jaw chuck may be mounted on the spindle nose of the dividing head in the same way as on a lathe.

11.9 Cutting speeds and feeds

Table 11.1 lists some typical values for cutting speeds and feed rates for milling operations when using high-speed steel (HSS) milling cutters.

TABLE 11.1 Cutting speeds and feeds for HSS milling cutters

Material being milled	Cutting speed (m/min)	Feed per tooth (chip thickness) (mm)					
		Face mill	Slab mill	Side & face	Slotting cutter	Slitting saw	End mill
Aluminium	70–100	0.2–0.8	0.2–0.6	0.15–0.4	0.1–0.2	0.05–0.1	0.1–0.4
Brass (alpha) (ductile)	35–50	0.15–0.6	0.15–0.5	0.1–0.3	0.07–0.15	0.035–0.075	0.07–0.3
Brass (free-cutting)	50–70	0.2–0.8	0.2–0.6	0.15–0.4	0.1–0.2	0.05–0.1	0.1–0.4
Bronze (phosphor)	20–35	0.07–0.3	0.07–0.25	0.05–0.15	0.04–0.07	0.02–0.04	0.04–0.15
Cast iron (grey)	25–40	0.1–0.4	0.1–0.3	0.07–0.2	0.05–0.1	0.025–0.05	0.05–0.2
Copper	35–45	0.1–0.4	0.1–0.3	0.07–0.2	0.05–0.1	0.025–0.05	0.05–0.2
Steel (mild)	30–40	0.1–0.4	0.1–0.3	0.07–0.2	0.05–0.1	0.025–0.05	0.05–0.2
Steel (medium carbon)	20–30	0.07–0.3	0.07–0.25	0.05–0.15	0.04–0.07	0.02–0.04	0.04–0.15
Steel (alloy – high tensile)	5–8	0.05–0.2	0.05–0.15	0.035–0.1	0.025–0.05	0.015–0.025	0.025–0.1
Thermosetting plastic*	20–30	0.15–0.5	0.15–0.5	0.1–0.3	0.07–0.15	0.035–0.075	0.07–0.3

*Low speed due to abrasive properties.

Notes:

1. The lower speed range is suitable for heavy, roughing cuts.
The higher speed range is suitable for light, finishing cuts.
2. The feed is selected to give the required surface finish and rate of metal removal.

These are only an approximate guide and you should consult the manufacturers' data sheets, manuals or wall charts for more specific information. When using carbide and coated carbide-tipped cutters it is important to use the manufacturers' data sheets for speeds and feeds in order to obtain the maximum benefit from these more expensive cutters.

Cutting speed calculations on milling machines using high-speed steel cutting tools are the same as those we considered for the centre lathe. We still have to calculate the spindle speed in rev/min given the cutting speed for the material of the workpiece but this time we use the diameter of the cutter not the diameter of the workpiece. Again, the machine is set to the nearest spindle speed *below* the calculated value to avoid damage through overheating. This is particularly important for milling cutters as they are expensive and more difficult to regrind than single point lathe tools, to avoid damage to the cutter.

Example 11.1 Calculate the spindle speed in rev/min for a milling cutter 125 mm in diameter, operating at a cutting speed of 30 m/min for low carbon (mild) steel. For this example take $\pi = 3$ since we work only to the nearest speed on the gearbox anyway.

$$\begin{aligned} N &= \frac{1000S}{\pi D} && \text{where: } N = \text{spindle speed} \\ &= \frac{1000 \times 30}{3 \times 125} && S = 30 \text{ m/min} \\ &= \mathbf{80 \text{ rev/min}} \end{aligned}$$

Calculations for the table feed rate for milling are somewhat different to the feed calculations associated with centre lathe turning. In centre lathe turning you calculated the feed rate as the distance moved by the tool per revolution of the work in rev/min. When calculating feed rates for milling machines, this is stated as the distance moved by the machine table per minute based on the rate per tooth of the cutter and the number of teeth. The cutting speeds and feeds given in manufacturers' handbooks and wall charts are a useful guide. However, as in all machining operations, the actual speeds and feeds chosen will depend upon:

- The surface finish required.
- The rate of metal removal required.
- The power of the machine.
- The rigidity of the machine.
- The rigidity of the work.
- The security of the workholding device.
- The material from which the work is made.

- The type of cutter, the material from which it is made, and its tooth form.
 - Whether or not a coolant is used and the flow rate if a coolant is used.
-

Example 11.2 Calculate the table feed rate in mm/min for a 12 tooth cutter revolving at 80 rev/min (see Example 5.3) when the feed per tooth is 0.1 mm.

$$\begin{aligned}\text{Feed/rev} &= \text{feed/tooth} \times \text{number of teeth} \\ &= 0.1 \text{ mm} \times 12 \\ &= \mathbf{1.2 \text{ mm/rev}}\end{aligned}$$

$$\begin{aligned}\text{Table feed} &= \text{feed/rev} \times \text{rev/min for cutter} \\ &= 1.2 \text{ mm/rev} \times 80 \text{ rev/min} \\ &= \mathbf{96 \text{ mm/min}}\end{aligned}$$

So the cutter will rotate at 80 rev/min and the table and workpiece will move past it at a feed rate of 96 mm/min.

We can also use this information to determine the cutting time taken to machine a particular surface, as in the following example.

Example 11.3 Using the following data, calculate the time taken to complete a 270 millimetre long cut using a slab mill (roller mill). Take π as 3.

$$\text{Diameter of cutter} = 125 \text{ mm}$$

$$\text{Number of teeth} = 6$$

$$\text{Feed/tooth} = 0.05 \text{ mm}$$

$$\text{Cutting speed} = 45 \text{ m/min}$$

$$\begin{aligned}N &= \frac{1000S}{\pi D} && \text{where: } N = \text{spindle speed (rev/min)} \\ &= \frac{1000 \times 45}{3 \times 125} && S = 45 \text{ m/min} \\ &= \mathbf{120 \text{ rev/min}} \dots (1) && \pi = 3 \\ &&& D = 125 \text{ mm}\end{aligned}$$

$$\begin{aligned}\text{Feed/rev} &= \text{feed/tooth} \times \text{number of teeth} \\ &= 0.05 \text{ mm/tooth} \times 6 \\ &= \mathbf{0.3 \text{ mm/rev}}\end{aligned}$$

$$\begin{aligned}\text{Table feed} &= \text{feed/rev} \times \text{number of teeth} \\ &= 0.05 \text{ mm/rev} \times 120 \text{ rev/min (from 1)} \\ &= \mathbf{36 \text{ mm/min}} \dots (2)\end{aligned}$$

$$\begin{aligned}
 \text{Time to complete 270 mm cut} &= \frac{\text{length of cut}}{\text{table feed}} \\
 &= \frac{270 \text{ mm}}{36 \text{ mm/min}} \quad (\text{from 2}) \\
 &= \mathbf{7.5 \text{ min}}
 \end{aligned}$$

11.10 Squaring up a blank on a horizontal milling machine

Before finding out how to square up a blank on a milling machine we must consider a problem that can occur when holding work in a machine vice. Like all machine vices we use the fixed jaw as a datum surface perpendicular to the machine worktable and the slideways of the vice as a datum surface parallel to the machine worktable. The moving jaw slides along the slideways machined into the body of the vice. For the jaw to slide there has to be clearance and, in time, wear will also take place. Since the clamping forces are offset they form a *couple* that tends to rotate the moving jaw as shown in Fig. 11.26(a). This tends to lift the work off its seating and tilt it causing loss of parallelism in the workpiece as shown in Fig. 11.26(b). To prevent this happening the vice must be kept in good condition. If there is difficulty in getting the work to seat properly on the parallel strips due to vice wear, a piece of steel rod of circular cross-section can be placed between the moving jaw and the workpiece as shown in Fig. 11.26(c). Any lift in the moving jaw, as

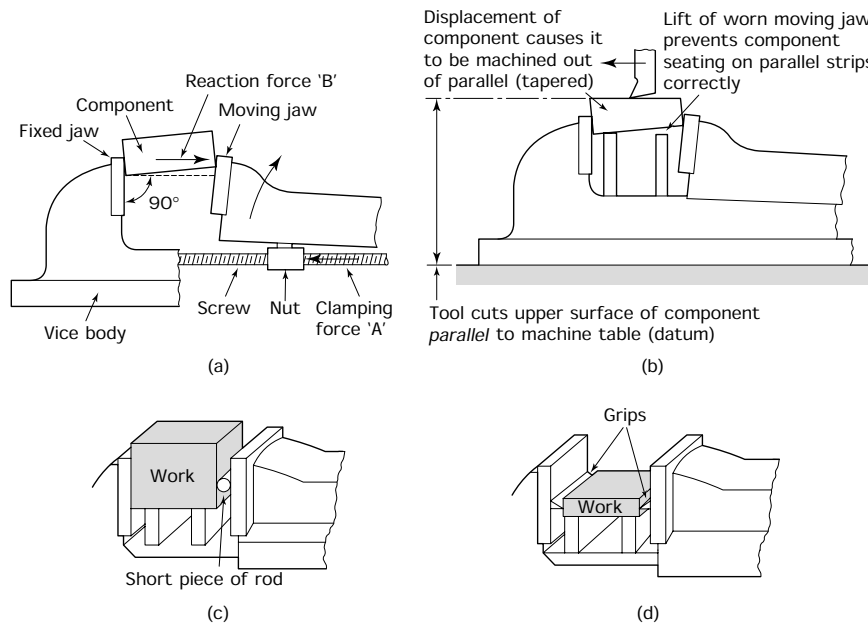


Figure 11.26 Effect of wear in a machine vice: (a) forces A and B form a 'couple' that tries to rotate the moving jaw; if the slides are worn the moving jaw will lift and displace the component being held, as shown; (b) lack of parallelism due to worn vice; (c) use of cylindrical packing; (d) use of grips

the vice is tightened, results in the rod rolling up the side face of the workpiece which remains tightly clamped against the datum surfaces of the vice. Grips as shown in Fig. 11.26(d) may be used where it is more important to pull the work down onto the parallels than to keep it against the fixed jaw. The side and bottom faces of the triangular grips are just over 90° so that as the vice is tightened up the grips pull down on the workpiece and hold it tightly against the parallel strips.

To square up the blank, the vice jaws are set parallel to the worktable with a DTI as shown in Fig. 11.27. The work is held down on the parallel strips using grips as just described and the first face is machined. This

-
- 1 Set vice jaws parallel to table using a DTI
When vice is correctly set the DTI reading should be constant as it travels along the parallel strip
 - 2 Set sawn blank in vice using grips
Mill surface 'A' using a slab (roller) mill
 - 3 Turn job through 90° so that previously machined surface (A) is against fixed jaw of vice; this ensures surface (A) and (B) are perpendicular to each other
Machine surface 'B'
 - 4 Turn job through 90° and machine surface 'C' until 40 mm thick; check thickness at each end of job to ensure parallelism
 - 5 Turn job through 90° again and machine surface 'D' until job is 65 mm wide; check width at each end to ensure parallelism
 - 6 Turn vice through 90° and check with DTI parallel to spindle axis
 - 7 Use side and face milling cutter to machine end square
Wind table across and machine to length; check length with vernier calliper

Figure 11.27 Operation sequence to square up a blank on a horizontal milling machine

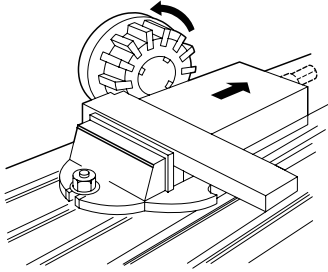


Figure 11.28 Machining the ends of larger blanks

face is then used as a datum surface and is held against the fixed jaw using a piece of round rod to prevent the work lifting as the vice is tightened. The next cut is taken and we now have two surfaces machined at right angles to each other. The remaining faces can be machined to size and the work is square. Finally, the vice is reset with its fixed jaw perpendicular to the machine worktable using a DTI as shown. The ends of the blank are then machined using a side and face milling cutter. For large work a face mill can be mounted directly into the machine spindle as shown in Fig. 11.28.

11.11 Milling a step (horizontal milling machine)

The sequence for milling a step is shown in Fig. 11.29. Let's assume that the blank has already been squared up by one or other of the techniques already described. We will also assume that the position of the step has been marked out and that the marking-out lines have been preserved with dot punch marks. Figure 11.29 shows the work being roughed out using the scribed lines as a guide.

- Do not work right up to the lines but leave some metal for finishing to size.
- Check the depth of the roughed-out slot using a depth micrometer or a vernier depth gauge.

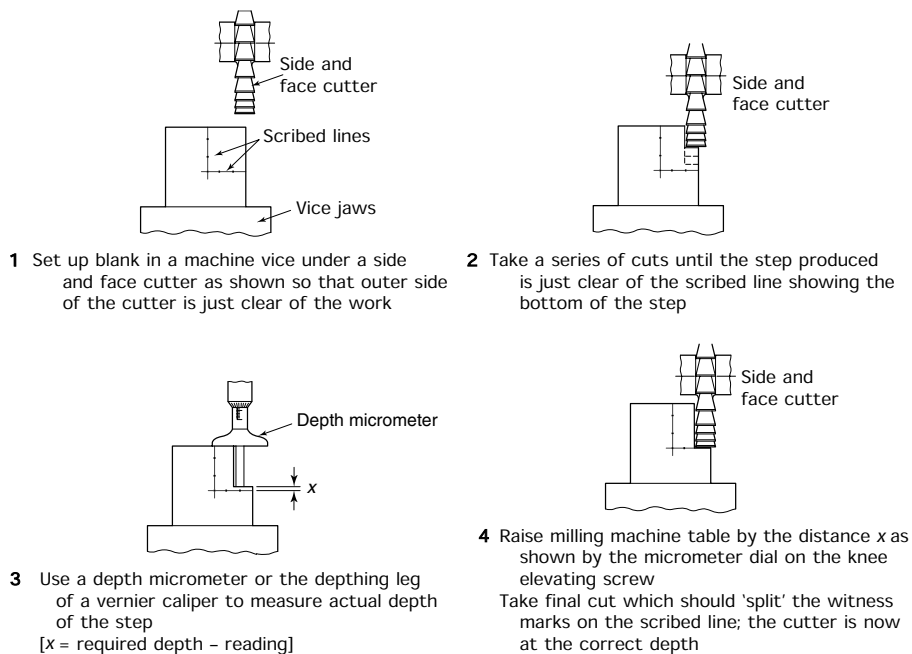
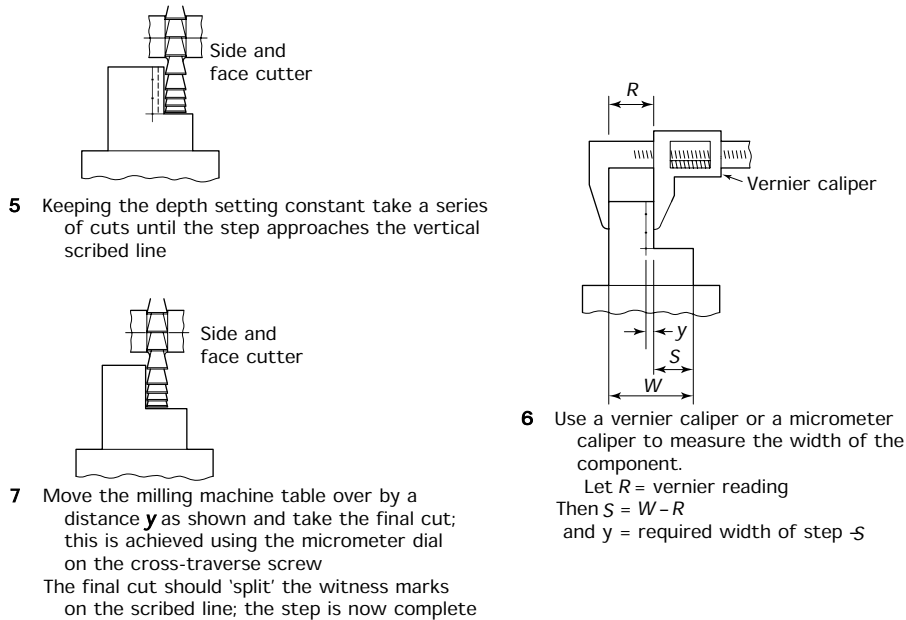


Figure 11.29 Machining a step using a horizontal milling machine

**Figure 11.29** (continued)

- Use the micrometer dials of the machine to increase the depth of cut to within a few 'thou' (inch measurements) or a few hundredths of a millimetre (metric measurement) and check again.
- Use the micrometer dial of the knee elevating screw of the machine to increase the cut to the finished depth.
- Now repeat this procedure to set the width of the step. This time you will use either a micrometer caliper or a vernier caliper to take the measurements. The machine will be set using the micrometer dial of the saddle cross traverse screw.

11.12 Milling a step (vertical milling machine)

The process is the same as just described except that an end mill or a shell end mill will be used. Remember that:

- You will be cutting on the side as well as the end of the end mill so lighter cuts will have to be taken than when using a side and face mill on a horizontal machine. This is particularly true if a 'long reach' end mill is being used for a deep step.
- An end mill cannot be plunged into the work; it has to be fed in from the side of the work.

11.13 Milling a slot (horizontal milling machine)

Sometimes you cannot work steadily up to a scribed line and finish the cut to size using measuring instruments and the micrometer dials of the machine. For example, when cutting a slot with a slitting saw or a slot

mill whose thickness is equal to the width of the slot, you can have only 'one bite at the cherry'. The work has to be positioned under the cutter in the correct position first time. The technique for positioning the cutter is shown in Fig. 11.30. Only light cuts should be taken to avoid overloading the cutter. Also, do not allow the cutter to become clogged with metal swarf. A good flow of coolant will help to wash the swarf away.

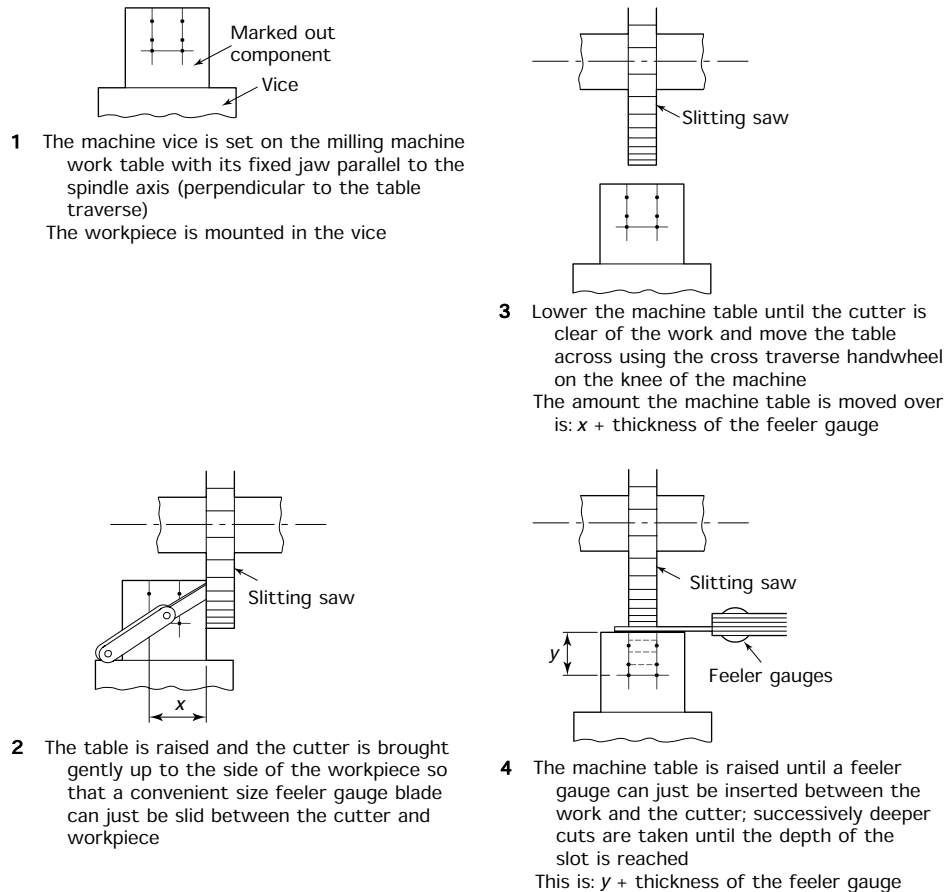


Figure 11.30 Machining a slot on a horizontal milling machine

11.14 Milling an angular surface

First of all the blank is squared up. Then it is marked out and mounted in the machine vice at a suitable angle so that the V-shape is clear of the vice jaws. A series of cuts can then be taken either using a side and face cutter on a horizontal spindle milling machine or a shell end mill on a vertical spindle milling machine.

Figure 11.31 shows how a bevel protractor is used to set the work to the required angle. In this example a side and face milling cutter is being used on a horizontal milling machine. A series of cuts is taken until the

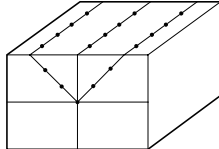
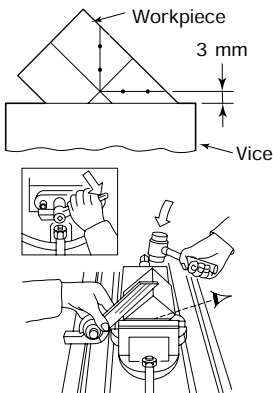
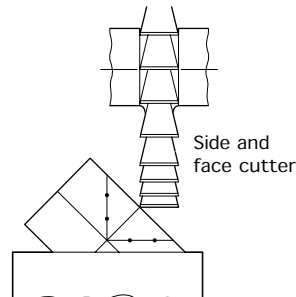
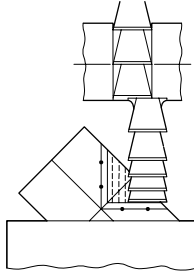
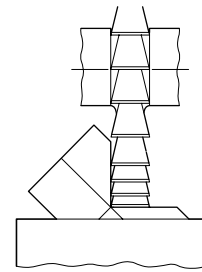
- 
- 1** Mark out position of 'V' on the end and top face of the blank
- 
- 2** Mount the marked out blank in the machine vice as shown with the lines of the 'V' vertical and horizontal; the horizontal line should be 3 mm above the jaws for cutter clearance
The blank setting at 45° can be checked by means of a bevel protractor as shown
- 
- 3** Select a side and face cutter of sufficient diameter that it can cut to the bottom of the 'V' without the arbor collars fouling the workpiece
Position the work using the knee cross-traverse and elevating controls; the corner of the cutter should just touch on the centre marked out line. Zero the micrometer dials
- 
- 4** Remove the surplus material in a series of even cuts until the cutter approaches the scribed lines
Note:
- Since the workpiece is only held by friction only light cuts can be taken or the workpiece may be dislodged
 - Check the angle of the workpiece again with the protractor before taking the finishing cuts and adjust if necessary
- 
- 5** Gently raise the machine table so that the face of the cutter just splits the horizontal marked out line on the workpiece
Remove the metal in even cuts as previously until the side of the cutter splits the vertical marked out line on the workpiece
Note:
- The V-block is now complete and can be removed from the vice
 - Remove all sharp corners and burrs with a fine file

Figure 11.31 Machining angular surfaces on a horizontal milling machine

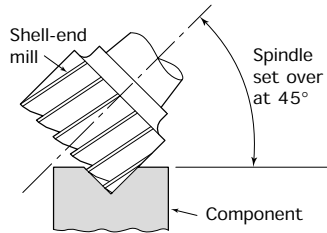


Figure 11.32 Milling a V-slot using a shell end mill on a vertical milling machine

marked-out lines are 'split'. Proof of the lines being split is provided by the dot punch 'witness' marks. Half the dots should remain if the line has been split accurately. The sequence of operations to produce the V-shaped slot is shown in Fig. 11.31.

Figure 11.32 shows an alternative way of producing the 'V' by using a shell end milling cutter in a vertical milling machine with the head and spindle inclined at 45° . This enables the work to be set in the vice in the normal way. Further, because the blank is resting on the bottom of the vice or on parallel packing strips, it is more rigidly supported and is less likely to be disturbed by the action of the cutter.

Exercises

11.1 Safety

- Describe FOUR safety precautions that should be taken when using a milling machine.
- Sketch any horizontal milling machine cutter guard with which you are familiar.

11.2 Milling cutters

- With the aid of a sketch show how the following cutting angles are applied to the tooth of a milling cutter.
 - Rake angle.
 - Clearance angle.
- With the aid of a sketch explain why milling cutter teeth have to have secondary clearance.
- With the aid of sketches show how the teeth of some milling cutters cut orthogonally whilst others can cut obliquely.
- With the aid of sketches explain the essential differences between *up-cut* and *down-cut* (climb) milling techniques. List the advantages and limitations of both techniques.

11.3 Milling machines

- With the aid of sketches, explain the essential differences between horizontal and vertical milling machines.
- With the aid of sketches show how a horizontal milling machine can produce surfaces that are:
 - parallel to the surface of the worktable;
 - perpendicular to the surface of the worktable;
 - perpendicular to the surface of the worktable but using a face milling cutter.
- With the aid of sketches show how a vertical milling machine can produce surfaces that are:
 - parallel to the surface of the worktable;
 - perpendicular to the surface of the worktable;
- Explain how the spindle speeds and feed rates for milling machines are related and how this relationship differs from that for centre lathes.

11.4 Selection of milling machines and milling cutters

- Figure 11.33 shows some simple components that require milling operations during their manufacture. For each

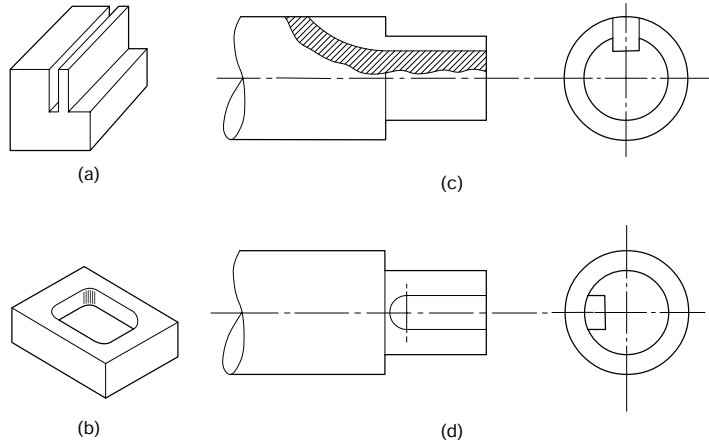


Figure 11.33 Exercise 11.4(a)

example, state the most suitable type of machine that should be used, giving the reasons for your choice.

- (b) Figure 11.34 shows some typical milling cutters. With the aid of sketches indicate a suitable application for each of the cutters.

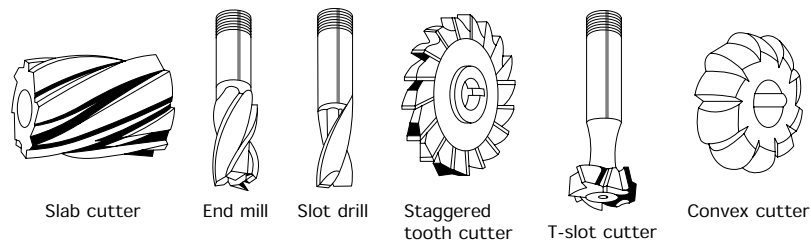


Figure 11.34 Exercise 11.4(b)

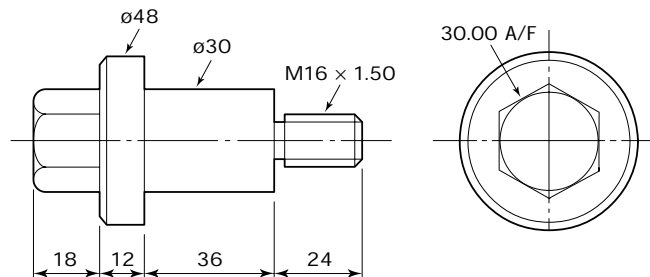
- (c) When ordering a cutter from the stores:
- (i) state FOUR essential factors that must be specified to ensure you get the correct cutter;
 - (ii) state FOUR cutter defects for which you should check for before using the cutter.

11.5 Mounting milling cutters

- (a) Briefly describe:
- (i) the purpose of the overarm steady;
 - (ii) how the overarm steady should be positioned.
- (b) With the aid of sketches briefly describe TWO typical applications of a stub arbor.
- (c) With the aid of sketches briefly explain the difference between *straddle milling* and *gang milling*.

11.6 *Workholding on a milling machine*

- (a) Small components are usually held in machine vices mounted on the worktable of the machine.
 - (i) State which jaw and which horizontal surface of a machine vice form the datum surfaces from which the workpiece is set.
 - (ii) Explain why machine vices are sometimes fitted with tenon blocks to engage the T-slots of the worktable.
 - (iii) Explain how you would set a machine vice NOT fitted with tenon blocks so as to ensure correct alignment.
- (b) When holding rough castings, clamped directly to the worktable of the machine, describe the precautions that should be taken to allow for inaccuracies in the cast surfaces and also to prevent damage to the machine table.
- (c) Sketch the set-up for machining the hexagon on the component shown in Fig. 11.35, using a direct indexing simple dividing head as previously described in this chapter. The component will be supplied turned ready for milling.

**Figure 11.35** *Exercise 11.6(c)***11.7** *Speeds and feeds*

- (a) Calculate the spindle speed in rev/min for a milling cutter 150 mm in diameter operating at a cutting speed of 25 m/min.
- (b) Calculate the table feed rate in mm/min for a 14 tooth cutter revolving at the speed calculated in (a) above when the feed per tooth is 0.1 mm.
- (c) Combining the results from (a) and (b) above, calculate the time taken to take a cut 250 mm long.

11.8 *Milling operations*

- (a) With the aid of sketches describe the manufacture of the component shown in Fig. 11.36, paying particular attention to the selection of the machine and cutter(s) and the method of workholding. List the equipment (other than spanners and keys) that you would require.

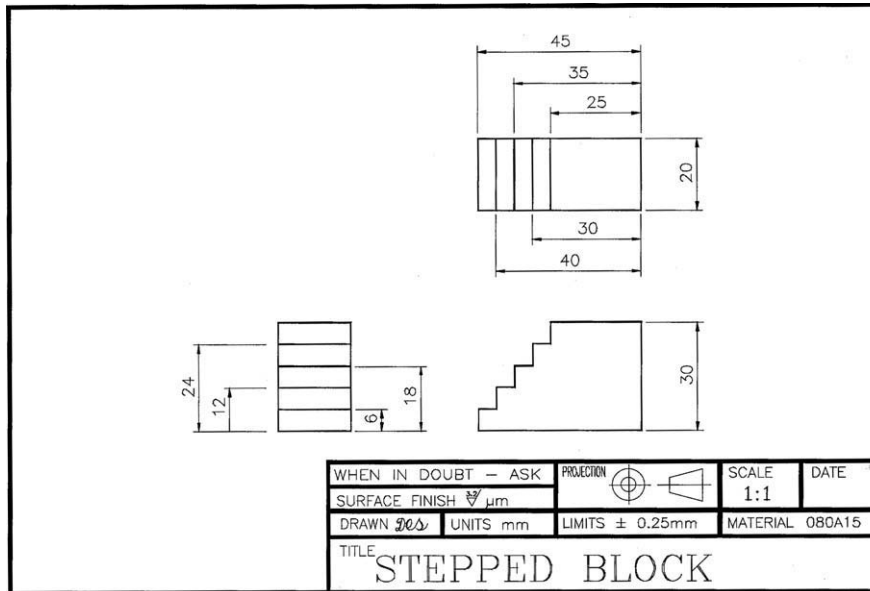


Figure 11.36 Exercise 11.8(a)

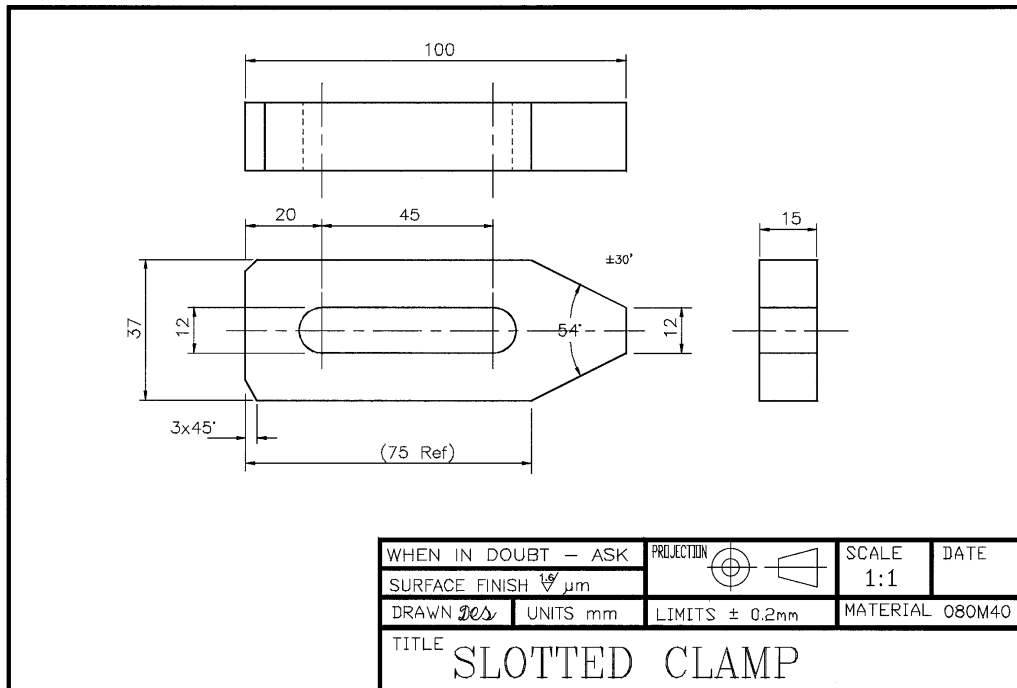


Figure 11.37 Exercise 11.8(b)

- (b) With the aid of sketches describe the manufacture of the component shown in Fig. 11.37, paying particular attention to the selection of the machine and cutter(s) and the method of workholding. List the equipment (other than spanners and keys) that you would require.

12 Grinding machines and processes

When you have read this chapter you should understand:

- The main features of typical surface grinding machines.
- The main movements of typical surface grinding machines.
- How to care for surface grinding machines in order to maintain their accuracy and alignments.
- The selection of a surface grinding machine appropriate to the work in hand.
- The setting and securing of a workpiece on a magnetic chuck.
- The correct setting and operation of a surface grinding machine.

12.1 Safety when grinding

The abrasive wheels used in grinding processes are relatively fragile and can be easily broken. If an abrasive wheel breaks whilst rotating at high speeds it can do considerable damage and cause serious accidents. For this reason great care must be taken in:

- Storing and handling abrasive wheels.
- Mounting and balancing abrasive wheels.
- Guarding abrasive wheels (burst containment).
- Truing and dressing abrasive wheels.
- Using abrasive wheels.

Because of their potential danger there are additional regulations that apply specifically to the use of abrasive wheels and grinding processes. We will now examine some of the more important provisions of the *Abrasive Wheel Regulations*.

12.1.1 Training and appointment of persons to mount wheels

Abrasive Wheel Regulation 9 states that no person shall mount an abrasive wheel unless that person:

- Has been trained in accordance with the training schedule of these regulations.

- Is competent to carry out that duty.
- Has been properly appointed and that the appointment has been confirmed by a signed and dated entry in the appropriate register. This entry must carry particulars of the class or description of the abrasive wheels that person is appointed to mount. Any such appointment can be revoked by the company by a signed and dated entry in the register.
- A copy of that entry or a certificate has been given to the appointed person and this must also indicate the particulars of the class or description of the abrasive wheels that person is appointed to mount.

The above comments do not apply to a person undergoing training in the work of mounting abrasive wheels, providing they are working directly under the supervision of a competent person (instructor) who has himself or herself been trained and appointed under these regulations. A trainee must be certified as soon as the training module has been satisfactorily completed.

12.1.2 Guards

Regulation 10 requires that a guard shall be provided and kept in position at every abrasive wheel unless the nature of the work absolutely precludes its use. An abrasive wheel guard has two main functions.

- To contain the broken pieces of the wheel in the event of it bursting.
- To prevent the operator, as far as possible, from coming into contact with the rapidly rotating wheel.

To achieve these aims, the wheel should be enclosed to the greatest possible extent, the opening being as small as possible consistent with the nature of the work being performed. Apart from certain guards for portable grinding machines, all abrasive wheel guards should be capable of adjustment. This is so that the whole wheel, except for that part necessarily exposed, can be enclosed. As the wheel wears down, the guard should be adjusted from time to time so as to maintain maximum protection.

The guard should be securely bolted or otherwise attached to the frame or body of the machine. On portable machines the guard should be attached by a clamp of unit construction, the clamp to be closed on the machine frame by a single high tensile bolt.

Except for very small machines, cast iron or similar brittle materials should not be used for abrasive wheel guards. Because of the magnitude of the forces involved when a wheel bursts, the sheet metal used for most cutter guards is unsuitable, and abrasive wheel guards should be fabricated by welding from substantial steel plate.

12.1.3 Wheel speeds

The overspeeding of abrasive wheels is a common cause of failure by bursting. For this reason the manufacturer's specified *maximum permissible speed* must never be exceeded. Regulation 6 requires that every

abrasive wheel having a diameter of more than 55 mm shall be marked with the maximum permissible speed at which it can safely be used, the speed, as specified by the manufacturer, to be stated in revs/min. The speed of smaller wheels shall be stated in a notice. In the case of mounted wheels and points, the overhang at the specified speed must also be stated in the notice.

12.1.4 Spindle speeds

Regulation 7 requires that the maximum working speed or speeds of every grinding machine shall be specified in a notice attached to the machine. This enables the person who is mounting an abrasive wheel on the machine to check that the speed of the spindle does not exceed the maximum permissible speed of the wheel.

12.1.5 Selection of wheels

Regulation 13 requires that in selecting a wheel, due account shall be taken of the factors that affect safety. Selecting the correct wheel for the workpiece is equally important for both safety and efficient production. As a general rule, soft wheels are selected for grinding hard workpiece materials. Similarly hard wheels are usually selected for the grinding of soft workpiece materials. The selection of abrasive wheels will be considered more fully in Section 12.4.

12.1.6 Misuse of the abrasive wheel

Wheel breakage can occur if the operator presses the workpiece against the abrasive wheel with excessive pressure. This may occur if the:

- Wheel is running slower than its recommended speed and is not cutting satisfactorily.
- Wrong wheel has been selected for the job in hand.
- Wheel has become loaded or glazed (see below and also Section 12.5).

Particular care must be taken when grinding on the sides of straight sided wheels. Such a technique is dangerous when the wheel is appreciably worn or if a sudden or excessive pressure is applied.

12.1.7 Truing and dressing

The wheel should be dressed when it becomes loaded or glazed. Loading and glazing prevent the wheel from cutting satisfactorily and can cause overheating of the work and also overheating of the abrasive wheel. Overheating of the wheel results in weakening of the bond and failure of the wheel. It also tempts the operator into pressing the work harder onto the wheel which can result in wheel failure (bursting).

Correct dressing of the abrasive wheel keeps the wheel running concentric with the spindle axis. This is essential:

- For maintaining wheel balance and preventing vibration patterns on the surface of the workpiece.

- For preventing vibration damage to the machine bearings.
- For accurate dimensional control.
- When off-hand grinding since it allows the workrest to be kept close to the periphery of the wheel. This prevents the work from being dragged down between the wheel and the workrest.

12.1.8 Eye protection

Persons carrying out dry grinding operations (no cutting fluid being used) and truing or dressing abrasive wheels are required to be provided with and to wear approved eye protectors (goggles) and dust masks.

12.2 Fundamental principles of grinding

Grinding is the name given to those processes which use abrasive particles for material removal. The abrasive particles are made by crushing hard, crystalline solids such as aluminium oxide (emery) and silicon carbide. Grinding wheels consist of large numbers of abrasive particles, called *grains*, held together by a *bond* to form a multi-tooth cutter similar in its action to a milling cutter. Since the grinding wheel has many more 'teeth' than a milling cutter and, because this reduces the 'chip clearance' between the teeth, it produces a vastly improved surface finish at the expense of a slower rate of material removal. The fact that the cutting points are irregularly shaped and randomly distributed over the active face of the tool enhances the surface finish produced by a grinding process. Figure 12.1 shows the dross from a grinding wheel highly magnified. It will be seen that the dross consists of particles of abrasive material stripped from the grinding wheel together with metallic chips that are remarkably similar in appearance to the chips produced by the milling process.

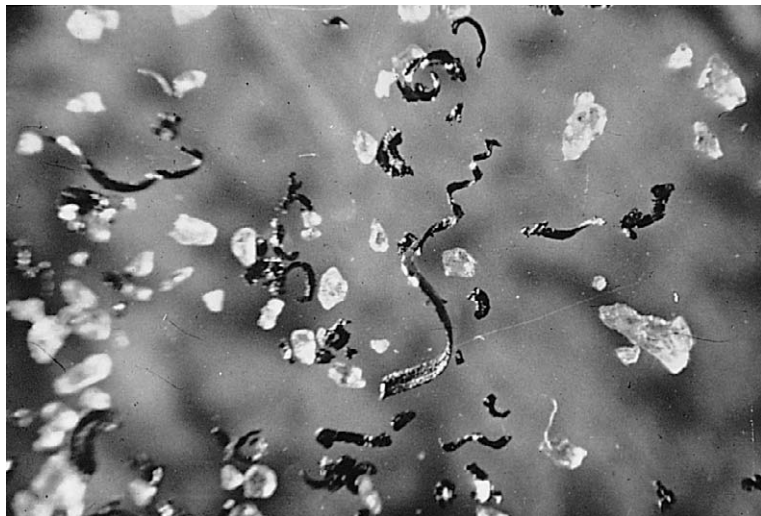


Figure 12.1 Grinding wheel dross

The grains at the surface of the wheel are called *active grains* because they are the ones that actually perform the cutting operation. In peripheral grinding, each active grain removes a short chip of gradually increasing thickness in a similar way to the tooth of a milling cutter as shown in Fig. 12.2. As grinding proceeds, the cutting edges of the grains become dulled and the forces acting on the grains increase until either the dulled grains fracture and expose new cutting surfaces, or the whole of the dulled grains are ripped from the wheel exposing new active grains. Therefore, grinding wheels have self-sharpening characteristics.

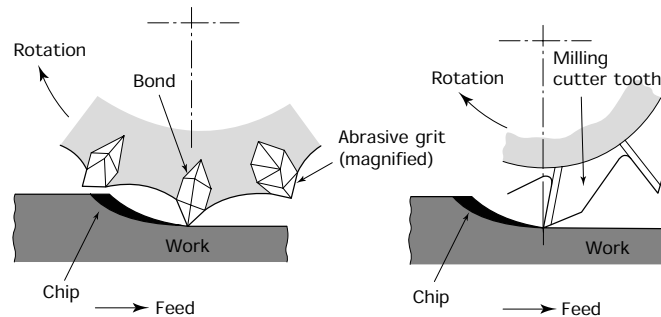


Figure 12.2 Cutting action of abrasive wheel grains

12.3 Grinding wheel specification

A grinding wheel consists of two constituents:

- The *abrasive* grains that do the cutting.
- The *bond* that holds the grains together.

The specification of a grinding wheel indicates its construction and its suitability for a particular operation. For example, let's consider a wheel carrying the marking:

38A60-J5V

This is interpreted as follows:

- 38A is the *abrasive type* (see Table 12.1).
- 60 is the *grit size* (see Table 12.2).
- J is the *grade* (see Table 12.3).
- 5 is the *structure* (see Table 12.4).
- V is the *bond material* (see Table 12.5).

Therefore a wheel carrying the marking 38A60-J5V has an aluminium oxide type abrasive, the abrasive grit has a medium to fine grain size, the grade of the wheel is soft, the structure has a medium spacing, and the grains are held together by a vitrified bond.

12.3.1 Abrasive

This must be chosen to suit the material being cut. As a general classification:

- ‘Brown’ aluminium oxide is used for grinding tough materials.
- ‘White’ aluminium oxide is used for grinding hard die steels and high-speed steel cutting tools.
- Silicon carbide (green grit) is used for very hard materials such as tungsten carbide tool tips.

Table 12.1 indicates how the abrasive type may be coded using the British Standard (BSI) marking system. The British Standard marking system calls only for ‘A’ for aluminium oxide abrasives or ‘C’ for silicon carbide abrasives. However, it does permit the use of a prefix to the A or the C so that specific abrasives can be identified within each broad classification. Table 12.2 compares the British Standard marking system with that of the Norton Abrasive Company.

TABLE 12.1 *British Standard abrasive marking system*

<i>Abrasive</i>			
<i>Aluminium oxide</i>		<i>Silicon carbide</i>	
Aloxite	A	Silicon carbide	C
Alundum	A	Black crystolon	37C
Bauxilite	A	Unirundum	C
Blue aloxite	BA	Green silicon carbide	GC
Mixed bauxilite	MA	Green crystolon No. 39	39C
Pink aloxite	PA		
White aloxite	AA		
White alundum	38A		
White bauxilite	WA		

TABLE 12.2 *Abrasive types (Norton abrasives)*

<i>Manufacturer's type code</i>	<i>BS code</i>	<i>Abrasive</i>	<i>Application</i>
A	A	Aluminium oxide	A high strength abrasive for hard, tough materials
32A	A	Aluminium oxide	Cool; fast cutting, for rapid stock removal
38A	A	Aluminium oxide	Light grinding of very hard steels
19A	A	Aluminium oxide	A milder abrasive than 38A used for cylindrical grinding
37C	C	Silicon carbide	For hard, brittle materials of high density such as cast iron
39C	C (green)	Silicon carbide	For very hard, brittle materials such as tungsten carbide

12.3.2 Grain size (grit size)

The number indicating the grain or grit size represents the number of openings per linear 25 mm in the sieve used to size the grains. The larger the grain size number, the finer the grain. Table 12.3 gives a general classification. The sizes listed as *very fine* are referred to as ‘flours’ and are used for polishing and super-finishing processes.

TABLE 12.3 *Grit size*

<i>Classification</i>	<i>Grit sizes</i>
Coarse	10, 12, 14, 16, 20, 24
Medium	30, 36, 40, 46, 54, 60
Fine	70, 80, 90, 100, 120, 150, 180
Very fine	220, 240, 280, 320, 400, 500, 600

12.3.3 Grade

This indicates the strength of the bond and therefore the ‘hardness’ of the wheel. In a *hard* wheel the bond is strong and securely anchors the grit in place, thus reducing the rate of wear. In a *soft* wheel the bond is weak and the grit is easily detached, resulting in a high rate of wear.

The bond must be carefully related to the use for which the wheel is intended. Too hard a wheel will result in dull, blunt grains being retained in the periphery of the wheel causing the generation of excessive heat at the tool/wheel interface with the resultant softening (blueing) of the tool being ground. Too soft a wheel would be uneconomical due to rapid wear and would also result in lack of control of dimensional accuracy in the workpiece when precision grinding. Table 12.4 gives a general classification of hardness using a letter code.

TABLE 12.4 *Grade*

<i>Classification</i>	<i>Letter codes</i>
Very soft	E, F, G
Soft	H, I, J, K
Medium	L, M, N, O
Hard	P, Q, R, S
Very hard	T, U, W, Z

12.3.4 Structure

This indicates the amount of bond between the grains and the closeness of adjacent grains. In milling cutter parlance it indicates the ‘*chip clearance*’. An open structured wheel cuts freely and tends to generate less heat in the cutting zone. Therefore an open structured wheel has ‘*free-cutting*’ and rapid material removal characteristics. However, it will not produce

such a good finish as a closer structured wheel. Table 12.5 gives a general classification of structure.

TABLE 12.5 *Structure*

<i>Classification</i>	<i>Structure numbers</i>
Close spacing	0, 1, 2, 3
Medium spacing	4, 5, 6
Wide spacing	7, 8, 9, 10, 11, 12

12.3.5 Bond

There is a wide range of bonds available and care must be taken to ensure that the bond is suitable for a given application, as the safe use of the wheel is very largely dependent upon this selection.

- *Vitrified bond.* This is the most widely used bond and is similar to glass in composition. It has a high porosity and strength, producing a wheel suitable for high rates of material removal. It is not adversely affected by water, acid, oils or ordinary temperature conditions.
- *Rubber bond.* This is used where a small amount of flexibility is required in the wheel, such as in thin cutting-off wheels and centreless grinding control wheels.
- *Resinoid (bakelite) bond.* This is used for high-speed wheels where the bursting forces are great. Such wheels are used in foundries for dressing castings. Resinoid bond wheels are also used for the larger sizes of cutting-off wheels. They are strong enough to withstand considerable abuse.
- *Shellac bond.* This is used for heavy duty, large diameter wheels, where a fine finish and cool cutting is required. Such wheels are used for grinding mill rolls.
- *Silicate bond.* This is little used for precision grinding. It is mainly used for finishing cutlery (knives) and edge tools such as carpenters' chisels.

Table 12.6 lists the literal code used to specify the bonding materials discussed above.

TABLE 12.6 *Bond*

<i>Classification</i>	<i>BS code</i>
Vitrified bond	V
Resinoid bond	B
Rubber bond	R
Shellac bond	E
Silicate bond	S

12.4 Grinding wheel selection

The correct selection of a grinding wheel depends upon many factors and in this section of the chapter it is possible to give only general 'guidelines'. Manufacturers' literature should be consulted for more precise information.

12.4.1 Material to be ground

- *Aluminium oxide* abrasives should be used on materials with relatively high tensile strengths.
- *Silicon carbide* abrasives should be used on materials with relatively low tensile strengths.
- A fine grain wheel can be used on hard, brittle materials.
- A coarser grain wheel should be used on soft, ductile materials.
- When considering the *grade*, a general guide is to use a soft grade of wheel for a hard workpiece, and a hard grade of wheel for a soft workpiece.
- When considering the *structure*, it is permissible to use a close structured wheel on hard, brittle materials, but a more open structured wheel should be used for soft, ductile materials.
- The *bond* is seldom influenced by the material being ground. It is usually selected to suit the process.

12.4.2 Rate of stock removal

- A coarse grain wheel should be used for rapid stock removal, but it will give a comparatively rough finish. A fine grain wheel should be used for finishing operations requiring low rates of stock removal.
- The structure of the wheel has a major effect on the rate of stock removal; an open structured wheel with a wide grain spacing being used for maximum stock removal whilst providing cool cutting conditions.
- It should be noted that the performance of a grinding wheel can be appreciably modified by the method of dressing (see Section 12.5) and the operating speed.

12.4.3 Bond

As explained in Section 12.3, the bond is selected for its mechanical properties. It must achieve a balance between:

- sufficient *strength* to resist the rotational, bursting forces and the applied cutting forces; and
- the requirements of cool cutting together with the controlled release of dulled grains and the exposure of fresh cutting edges.

12.4.4 Type of grinding machine

A heavy, rigidly constructed machine can produce accurate work using softer grade wheels. This reduces the possibility of overheating the work-piece and 'drawing' its temper (i.e. reducing its hardness) or, in extreme cases, causing surface cracking of the workpiece. Furthermore, broader wheels can be used and this increases the rate of metal removal without loss of accuracy.

12.4.5 Wheel speed

Variation in the surface speed of a grinding wheel has a profound effect upon its performance. Increasing the speed of the wheel causes it to behave as though it were of a harder grade than that marked upon it. Conversely, reducing the surface speed of a grinding wheel causes it to behave as though it were of a softer grade than that marked upon it.

Care must be taken when selecting a wheel to ensure that the bond has sufficient strength to resist the bursting effect of the rotational forces. Table 12.7 lists the recommended speeds for off-hand, toolroom, and light production grinding. *Never exceed the safe working speed marked on the wheel.*

TABLE 12.7 Recommended wheel speeds

	Wheel speed range (m/s)	Surface coverage range (feet/min)
Cylindrical grinding (vitrified or silicate bond)	33–25	6500–5000
Internal grinding	25–20	5000–4000
Surface grinding	33–20	6500–4000
Tool and cutter grinding	30–23	6000–4500

12.5 Grinding wheel defects

A clear understanding of grinding wheel defects is essential for safe working. A wheel that is loaded or glazed will not cut freely and if excess force is used the wheel may shatter. This is extremely dangerous.

12.5.1 Loading

When a soft material, such as a non-ferrous metal, is ground with an unsuitable wheel, the spaces between the grains become clogged with metal particles. Under such circumstances the particles of metal can often be seen embedded in the wheel. This condition is referred to as loading and is detrimental to the cutting action of the grinding wheel. Loading destroys the clearance between the grains, causing them to rub rather than to cut.

This results in excessive force having to be used to press the work against the wheel in an attempt to make the wheel cut. This in itself

may be sufficient to fracture the wheel. In addition, considerable heat is generated by the wheel rubbing instead of cutting and this may not only adversely affect the hardness of the component, but it may cause the wheel to overheat, the bond to weaken, and the wheel to burst.

12.5.2 Glazing

A wheel consisting of relatively tough grains, strongly bonded together, will exhibit the self-sharpening action (see Section 12.2) only to a small degree and will quickly develop a shiny, or *glazed*, appearance. This is due to the active grains becoming blunt and shiny over a large area. Like any other blunt cutting tool, a glazed wheel will not cut properly and this will lead to overheating of the workpiece and the wheel. Grinding under these conditions is inefficient and the force required to make the wheel cut may be sufficiently excessive to cause the wheel to burst. The only permanent remedy for glazing is the use of a softer grade of wheel.

12.5.3 Damage

If you find the abrasive wheel of a grinding machine you are about to use is damaged or defective in any way *do not attempt to start up the machine*. Report the damage immediately to your instructor or your supervisor. Damage may consist of the wheel being chipped, cracked, worn unevenly or dressed on the side until it is dangerously thin. Vibration caused by lack of balance or worn spindle bearings should also be reported. In addition to wheel faults, report any missing or faulty guards or incorrectly adjusted work rests. These must be corrected or replaced by a qualified person before you use the machine.

12.6 Grinding wheel dressing and truing

To make a 'glazed' or 'loaded' abrasive wheel serviceable or to 'true' the wheel so that its circumference is concentric with the spindle axis, the wheel must be *dressed*. There are various devices used to dress grinding wheels but they all have the same aims. These are:

- To remove blunt grains from the matrix of the bond.
- To fracture the blunt grains so that they exhibit fresh, sharp cutting edges.
- To remove any foreign matter that may be embedded in the wheel.
- To ensure the periphery of the wheel is concentric (running true) with the spindle axis.

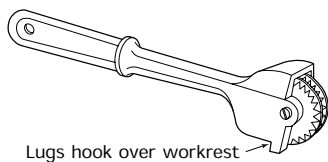


Figure 12.3 *Huntington wheel dresser*

12.6.1 Huntington type wheel dresser

This is shown in Fig. 12.3. The star wheels dig into the wheel and break out the blunt grains and any foreign matter that may be clogging the wheel. Since the star wheels rotate with the grinding wheel little abrasive

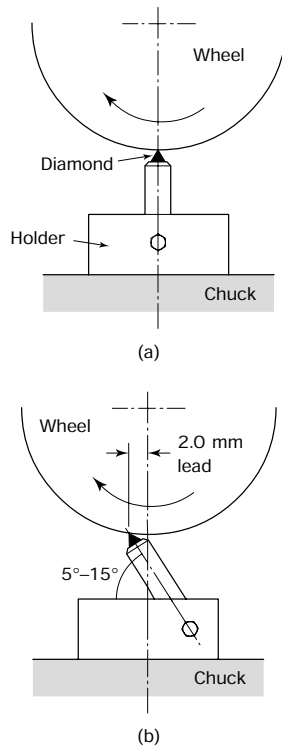


Figure 12.4 *Diamond wheel dresser: (a) incorrect – tip of diamond will wear flat, this will blunt the new abrasive grains as they are exposed; (b) correct – diamond leading wheel centre and trailing direction of rotation, the diamond will keep sharp and dress cleanly*

action takes place and wear of the star wheels is minimal. This type of wheel dressing device is widely used for pedestal type, off-hand grinding machines, but it is not suitable for dressing and truing the wheels of precision grinding machines.

12.6.2 The diamond wheel dresser

This is shown in Fig. 12.4. Generally, Brown Burt stones from Africa are used since these are useless as gem stones and are, therefore, relatively cheap. The diamond cuts the wheel to shape and is used for dressing and truing the wheels on precision grinding machines, such as surface and cylindrical grinding machines. The diamond holder should be rotated from time to time to maintain the shape of the stone and prevent it from becoming blunt.

- Figure 12.4(a) shows the diamond being used incorrectly. Used in this way, the diamond will develop a ‘flat’, and this will blunt the new grains as they are exposed.
- Figure 12.4(b) shows the correct way to use the diamond. It should trail the direction of rotation of the wheel by an angle of 5° to 15°, but lead the centre of rotation slightly. This will maintain the shape of the diamond so that it will keep sharp and dress cleanly.

The effective structure of the wheel can also be controlled to some extent by the way in which the wheel is dressed. Traversing the diamond rapidly across the face of the wheel has the effect of opening the structure, whilst a slow traverse has the effect of making the wheel cut as though it had a close structure.

12.6.3 The dressing stick

This consists of a stick of coarse abrasive crystals bonded together. It is used for removing the sharp corners from grinding wheels and for dressing small, mounted wheels. It is also used for relieving the sides of grinding wheels when working up to a shoulder.

12.7 Grinding wheel balancing

Precision grinding machines make provision for balancing the grinding wheel and its hub. An out-of-balance wheel produces vibration, causing a ‘chessboard’ pattern on the finished surface and, if allowed to continue, causing wear and damage to the spindle bearings. Large and heavy grinding wheels also need to be balanced, since the out-of-balance forces can be very considerable and may cause the wheel to burst.

Unlike pedestal and bench type off-hand grinding machines where the wheel has a lead bush and is mounted directly onto the spindle of the machine, the abrasive wheels of precision grinding machines do not have a lead bush but are mounted directly onto a separate hub. This, in turn, is mounted on the machine spindle. To effectively carry out the balancing of the grinding wheel a balancing stand of the type shown in Fig. 12.5

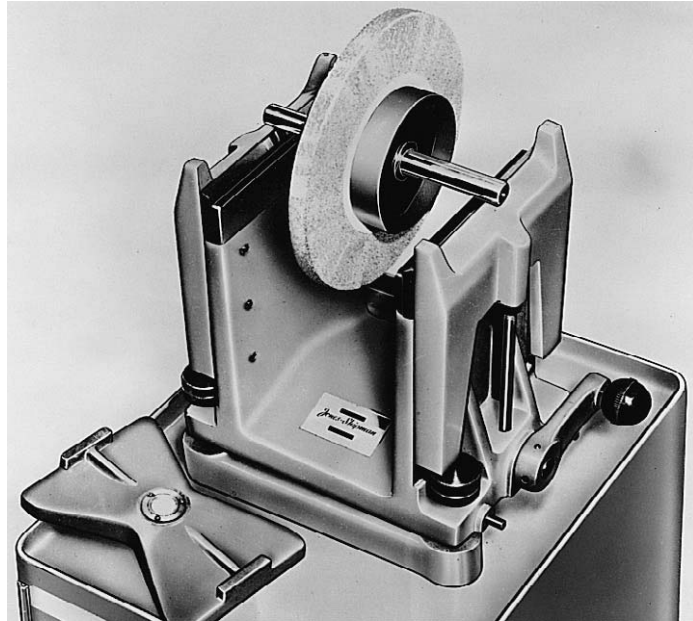


Figure 12.5 *Grinding wheel balancing stand*

should be used. The hardened steel knife edges can be levelled by means of two adjusting screws. A levelling plate with a sensitive bubble level is positioned temporarily across the knife edges and indicates when they are level in all directions.

The hub usually contains adjustable balance weights and the procedure for the static balancing of a grinding wheel and hub assembly is as follows.

- After mounting, the grinding wheel should be trued on the machine before balancing and it may require rebalancing from time to time as it wears down.
- Position the three balance segments (weights) equidistant around the face of the flange as shown in Fig. 12.6(a). Grub screws are provided

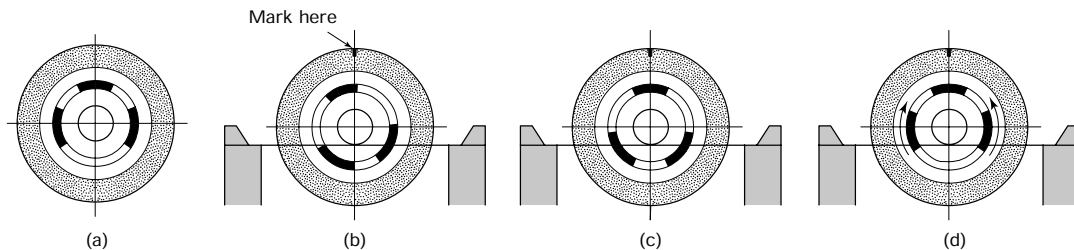


Figure 12.6 *Balancing procedure (reproduced courtesy of Jones and Shipman plc)*

for clamping the balance weight in position when the balance point is reached.

- To balance the wheel and hub they are first mounted on a mandrel which, in turn, is supported on the knife edges of the balancing stand. Allow the wheel and hub to turn freely. The wheel will roll back and forth until it stops with the heaviest part of the assembly at the bottom. When stationary, mark the top centre of the wheel with chalk as shown in Fig. 12.6(b).
- Move the segments equally round the flange until one segment is aligned with the mark as shown in Fig. 12.6(c).
- If movement still occurs, move the other two segments gradually towards the mark, as shown in Fig. 12.6(d) until the wheel and hub remain stationary in any position.

The grinding wheel and hub are removed from the mandrel and are carefully mounted on the grinding machine spindle, where the wheel is retrued ready for use.

12.8 The double-ended off-hand grinding machine

Figure 12.7(a) shows a typical double-ended, off-hand grinding machine widely used in workshops for sharpening single point cutting tools. It uses plain cylindrical grinding wheels of the type shown in Fig. 12.7(b).

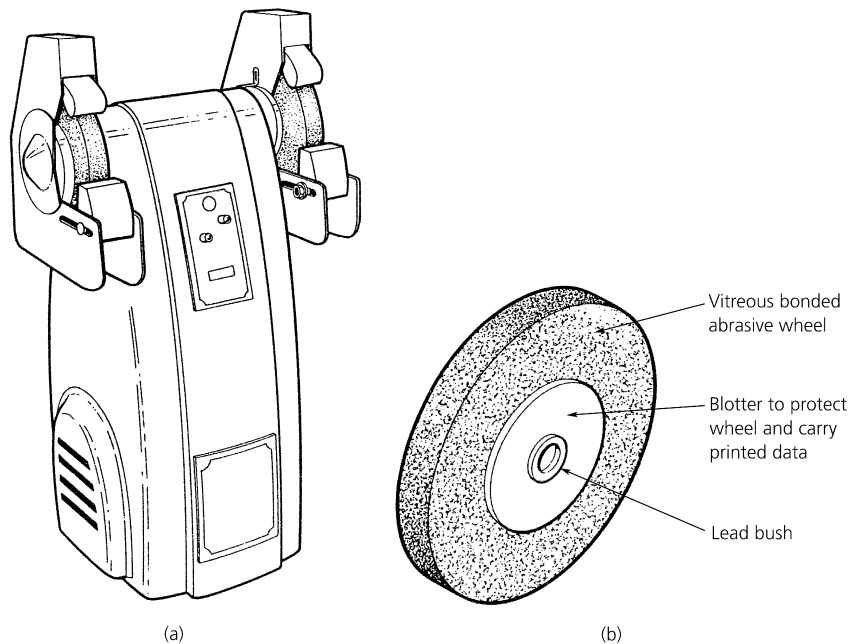


Figure 12.7 Double-ended, off-hand grinding machine

Because of its apparent simplicity, this type of grinding machine comes in for more than its fair share of abuse. For *safe* and *efficient* cutting the grinding wheel must be correctly mounted and correctly used. Let's now consider the correct way to mount a grinding wheel on this type of machine. Remember that under the Abrasive Wheel Regulations already discussed in this chapter, only certificated personnel and trainees under the direct supervision of a certificated person may change a grinding wheel.

For the following notes on mounting a new grinding wheel, refer mainly to Figs 12.8, 12.9 and 12.10.

- For the names of the parts of the wheel mounting assembly see Fig. 12.8(a).

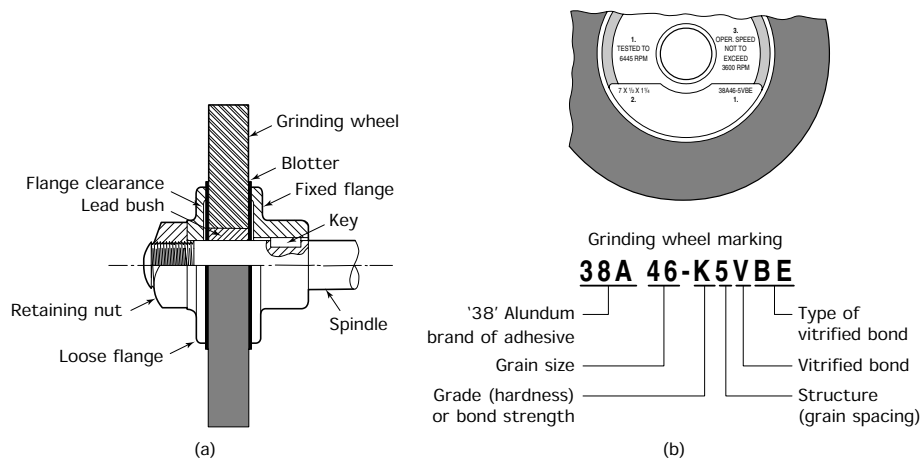


Figure 12.8 *Mounting a grinding wheel (stage 1): (a) the wheel mounting; (b) checking the new wheel (reproduced courtesy of Norton Grinding Wheel Co.)*

- Remove the securing nut. Viewed from the front of the machine, the left-hand wheel nut will have a left-hand thread. The right-hand wheel nut will have a right-hand thread.
- Remove the outer (loose) flange and the wheel that is to be discarded.
- Clean the spindle and wheel flanges to remove any trace of the old wheel and any burrs that may be present.
- Check that the new wheel is of suitable size and type for the machine and the work it is to perform. This information is printed on the 'blotters' on each side of the wheel as shown in Fig. 12.8(b).
- Check particularly that the operating speed is correct. Remember that the spindle speed must be marked on the machine.
- Check that the wheel is not cracked or faulty by 'ringing' it as shown in Fig. 12.9(a). To do this the wheel is freely suspended on stout twine

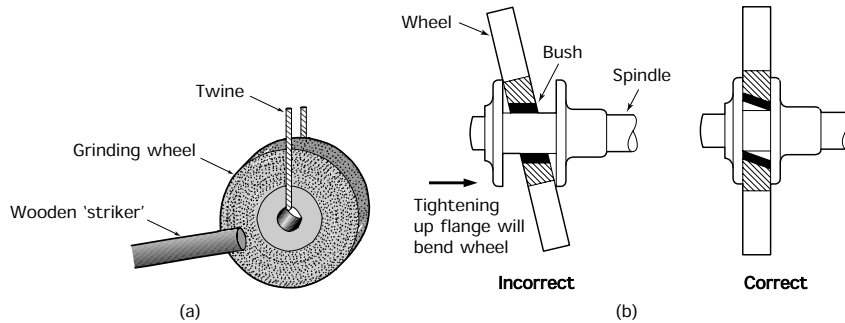


Figure 12.9 Mounting a grinding wheel (stage 2): (a) 'ringing' a grinding wheel; (b) fitting the bush: incorrect – if the lead bush in the centre of the wheel is too tight a fit on the spindle, there is a danger that the wheel will crack as the flanges are tightened up; correct – the bush is eased out with a three-square scraper until the wheel can float on the spindle, it will then pull up square with the fixed flange without cracking. (Note: The misalignment of the bush has been exaggerated for clarity)

and *lightly* tapped with a wooden rod. If the wheel is free from cracks or manufacturing faults, such as voids, it will 'ring' with a clear note.

- Slip the wheel onto the spindle. The lead bush in the centre of the wheel should be an easy fit on the spindle. If it is tight the abrasive wheel may twist and crack as the flanges are tightened up. Tight bushes should be opened up with a three-square scraper so that the wheel can float into position as shown in Fig. 12.9(b). The error in the bush has been exaggerated for clarity.
- Replace the 'loose' flange and check that the 'blotters' on the sides of the abrasive wheel are slightly larger than the flanges. The blotters

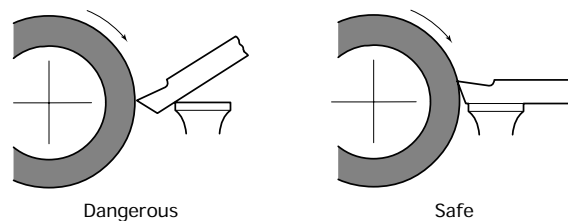
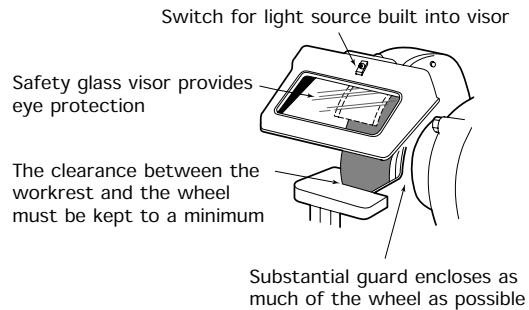


Figure 12.10 Setting the wheel guard and workrest adjustment

prevent the sharp edges of the flanges from biting into the wheel and starting a crack. The diameter of the flanges should be at least half the diameter of the wheel to give it adequate support.

- Replace the securing nut on the spindle and tighten it up. Use only the minimum of force to secure the wheel. Excessive tightening will crush and crack the wheel.
- Replace the wheel guard and adjust the visor and workrest as shown in Fig. 12.10.
- Test the wheel by running it up to speed. *DO NOT stand in front of the wheel whilst testing it in case it shatters.*
- Finally, true the wheel ready for use.

12.9 Resharpener hand tools and single point cutting tools

The off-hand grinding machine just described is used mainly for resharpening workshop hand tools and single point tools such as lathe tools and shaping machine tools. We will now look at some examples of how this should be done.

12.9.1 Chisels

These are ground as shown in Fig. 12.11(a). The cutting edge should be slightly radiused by rocking the chisel from side to side as shown.

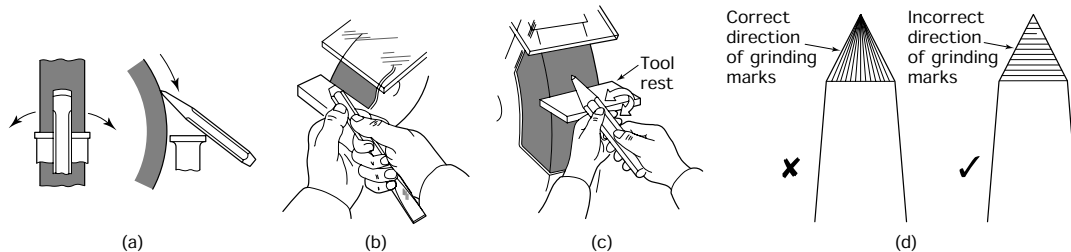


Figure 12.11 Sharpening bench tools: (a) sharpening a cold chisel – the cutting edge should be slightly radiused by rocking the chisel from side to side as indicated; (b) removing a ‘mushroomed’ head; (c) sharpening a centre punch; (d) correct grinding of centre punch point

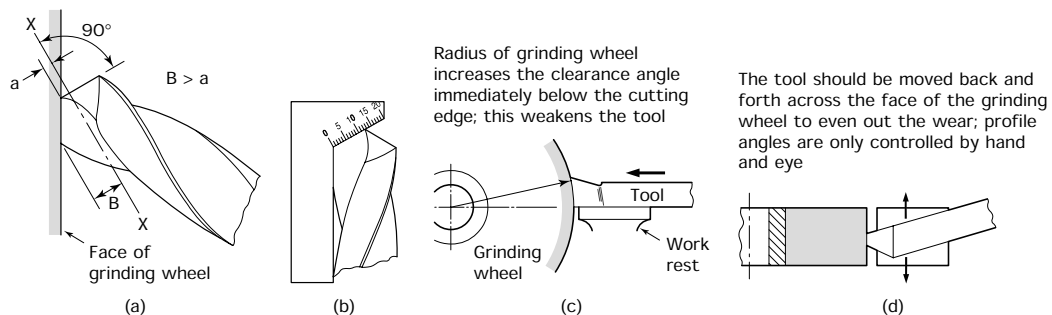


Figure 12.12 Sharpening drills and lathe tools: (a) off-hand grinding a drill point; (b) twist drill point angle and lip length gauge; (c) grinding the clearance angle; (d) grinding the plan profile

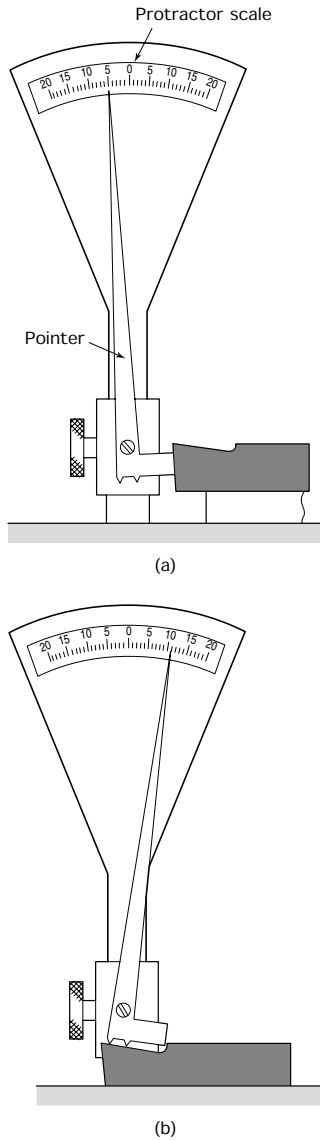


Figure 12.13 Lathe tool protractor: (a) checking the clearance angle; (b) checking the rake angle

12.10 Surface grinding machine

Take care not to overheat the chisel so that the cutting edge becomes discoloured. This will indicate that the chisel edge has become soft and useless. Any ‘mushrooming’ of the chisel head must be removed as shown in Fig. 12.11(b).

12.9.2 Centre punches and dot punches

Centre punches and dot punches are sharpened as shown in Fig. 12.11(c). The punch is held against the grinding wheel at the required angle and rotated between the thumb and forefinger to generate the conical point. Again, care must be taken not to soften the point of the punch by overheating it. The grinding marks must run from the point and not around it. This is shown in Fig. 12.11(d). Incorrect grinding will weaken the point causing it to crumble away.

12.9.3 Twist drills

These are most easily ground against the flat side of the grinding wheel as shown in Fig. 12.12(a). The straight cutting lip of the drill should lie vertically against the side of the wheel, and the drill should be gently rocked against the wheel about the axis XX to produce the point clearance. When the drill has been ground it should be checked on a drill point gauge as shown in Fig. 12.12(b). This ensures that the angles are equal and correct. It also ensures that the lips of the drill are of equal length. This is essential for efficient cutting and the production of accurately sized holes. Again care must be taken not to overheat the tool and soften it.

12.9.4 Single point tools

Lathe and shaping machine tools can also be ground on the off-hand grinding machine. Figure 12.12(c) shows the front clearance angle being ground, and Fig. 12.12(d) shows the plan trailing angle being ground. The tool shown is a straight nosed roughing tool for a lathe. Again care must be taken not to overheat the tool and soften it.

Experienced centre-lathe operators usually judge the cutting angles by ‘eye’ based on years of experience. However, more consistent results can be obtained by using a lathe tool protractor as shown in Fig. 12.13.

Surface grinding machines can be divided into four categories:

- Horizontal spindle – reciprocating table.
- Horizontal spindle – rotary table.

- Vertical spindle – reciprocating table.
- Vertical spindle – rotary table.

12.10.1 Horizontal spindle – reciprocating table

In this book we are concerned only with the horizontal spindle, reciprocating table type of machine as used in toolrooms for precision grinding. A typical example is shown in Fig. 12.14, and names its main features. As well as manual table traverse, it has a powered table traverse that is infinitely variable from zero to 25 m/min. The cross-feed may be adjusted manually or automatically. The automatic cross-feed rate is variable from about 0.2 mm to about 5 mm per pass of the wheel. The vertical in-feed of the wheel is very precisely controlled in increments of 0.005 mm. This type of machine uses grinding wheels that cut mainly on the periphery and, if wheel wear is to be kept to a minimum in the interest of dimensional accuracy, stock removal is rather limited. Precision surface grinding wheels are normally mounted on hubs containing balance weights as described in Section 12.7. Usually the surface grinder operator keeps a number of wheels of different specifications ready mounted on spare hubs so that they can be quickly interchanged as required.

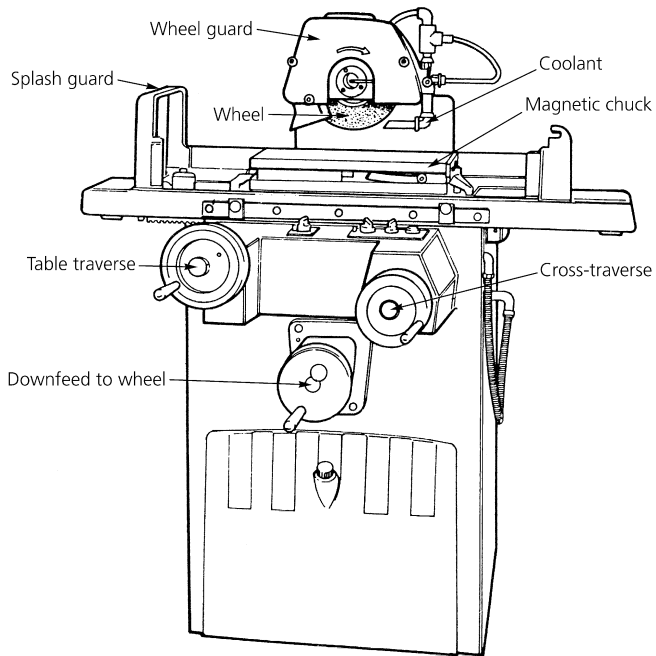


Figure 12.14 *Typical toolroom type surface grinding machine*

Figure 12.15 shows the relative geometrical movements and alignments for a horizontal spindle, reciprocating table grinding machine. You can see

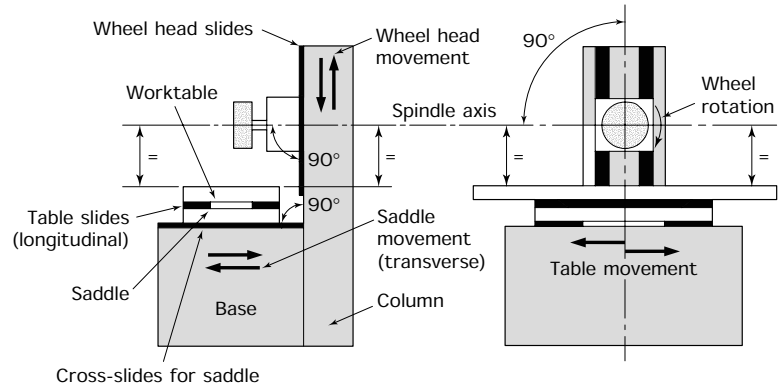


Figure 12.15 *Surface grinding machine: movements and alignments*

that they have a close similarity to those of a horizontal milling machine. This is not surprising since both machines are designed to produce plain surfaces using a cylindrical, rotating cutter whose axis is horizontal. The important difference is that whereas the milling machine is concerned with high rates of material removal, the surface grinding machine is designed to produce a surface of high dimensional accuracy and to a high standard of surface finish but with a low rate of material removal. Surface grinding is essentially a finishing process.

Most cutting takes place on the periphery of the wheel but shallow steps can be ground using the side of the wheel as well. Since the grinding wheel is relatively weak with respect to side forces, great care must be taken when working on the side of the wheel. Special attachments are available for dressing the grinding wheel to different shapes so that it can grind radii or other profiles.

12.11 Workholding

Workholding on surface grinding machines is usually effected by means of a magnetic chuck. However, this is possible only if a workpiece made from a ferromagnetic material such as steel is to be ground. Alternatively any of the techniques associated with the milling machine may be used. For example, direct clamping to the machine table, the use of vices of various types and also grinding fixtures.

12.11.1 Magnetic chucks

Most chucks employ permanent magnets. Figure 12.16(a) shows the construction of a standard chuck, and Fig. 12.16(b) shows the construction of a fine pole chuck for holding thinner components.

Figure 12.17(a) shows a section through a standard chuck in the 'ON' position. It will be seen that the lines of magnetic flux pass through the workpiece which must be made of a magnetic material. The magnets are mounted in a grid which can be offset by the operating handle. When this

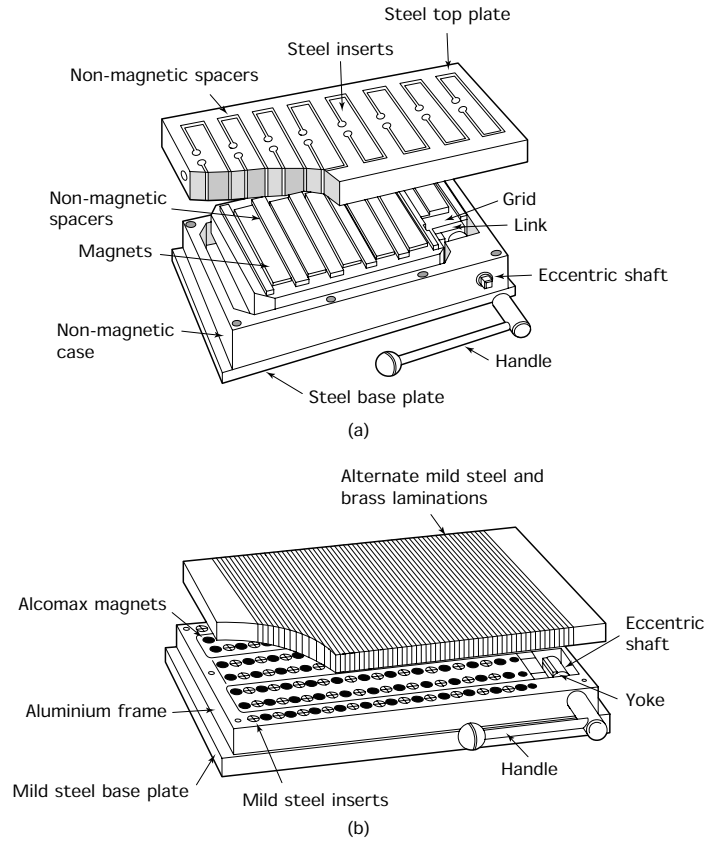


Figure 12.16 The magnetic chuck: (a) standard type chuck; (b) fine pole type chuck (reproduced courtesy of Eclipse Magnetics Ltd)

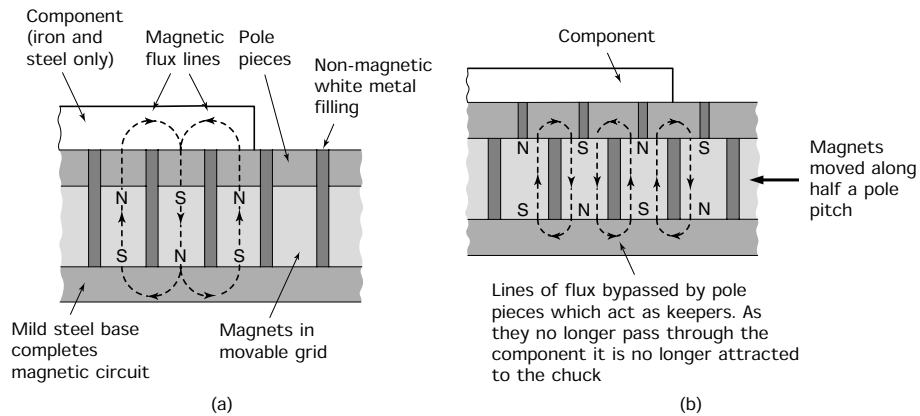


Figure 12.17 The magnetic chuck: principle of operation: (a) chuck 'on' – lines of flux pass through component; (b) chuck 'off' – lines of flux bypassed by pole pieces (reproduced courtesy of Eclipse Magnetics Ltd)



Figure 12.18 Typical demagnetizer (reproduced courtesy of Eclipse Magnetics Ltd)

is moved to the 'OFF' position as shown in Fig. 12.17(b), the magnetic flux field is bypassed through the pole pieces. In this position the pole pieces act as 'keepers' which prevent the magnets from losing their magnetism. In the OFF position no magnetic flux passes through the workpiece and, therefore, the workpiece is no longer attracted to the chuck. The flux field does not hold the component against the cutting forces directly, but provides a friction force between the component and the chuck. It is the friction that prevents the component from moving.

Hard steels tend to become magnetized and to hold their magnetism after they have been removed from the chuck. Demagnetizing is a simple operation. Figure 12.18 shows a typical *demagnetizer*. The top surface of this device consists of the two pole pieces of an electromagnet. The gap between them is filled by a soft, non-magnetic material. With the demagnetizer switched on, the magnetized workpiece is simply 'wiped' across the pole pieces. The alternating flux of the demagnetizer removes any residual magnetism in the workpiece material.

12.11.2 Mechanical clamping

For the general purpose workholding of non-magnetic materials on surface grinding machines and the holding of awkwardly shaped components of any metal, various mechanical workholding techniques can be used similar to the techniques used for milling. These can be:

- Workholding in a plain machine vice which, in turn, is mounted on the magnetic chuck as shown in Fig. 12.19(a).

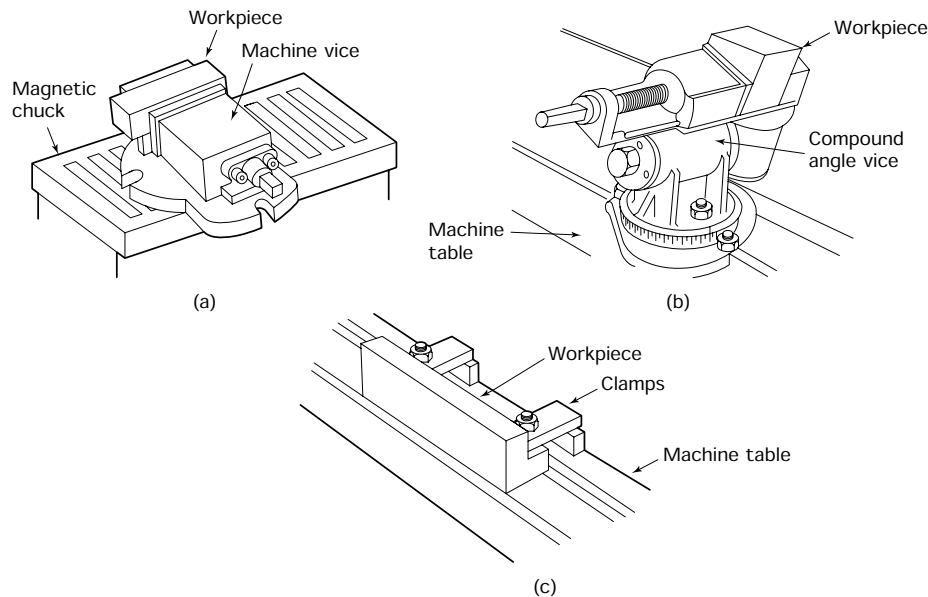


Figure 12.19 Mechanical clamping: (a) use of machine vice on a magnetic chuck; (b) use of a compound angle vice bolted directly to the machine table; (c) work clamped directly to machine table

- Workholding in a swivelling and tilting vice when a surface has to be ground at an angle to the machine table as shown in Fig. 12.19(b). Usually this type of vice is bolted directly to the machine table using the T-slots provided. This not only helps with setting the work but also compensates for the height of the vice. There would not be sufficient 'daylight' for it to pass under the grinding wheel if it was raised by the thickness of a magnetic chuck.
- The workpiece can also be clamped directly to the table of the machine as shown in Fig. 12.19(c).

12.12 Mounting a magnetic chuck on the worktable

Except for production grinding, most of the time the work is held on a permanent magnet chuck of the type described in the previous section, so let's now see how such a chuck is mounted on the machine table and trued up.

- Clean the table of the machine and the base of the chuck. Check for and carefully remove any burrs with a flat smooth oil stone.
- Seat the chuck centrally on the machine table, check that there is no rock. Absolute cleanliness is essential, there must be no oil or solid dirt particles between the table and the chuck.
- Lightly clamp into position as shown in Fig. 12.20(a).

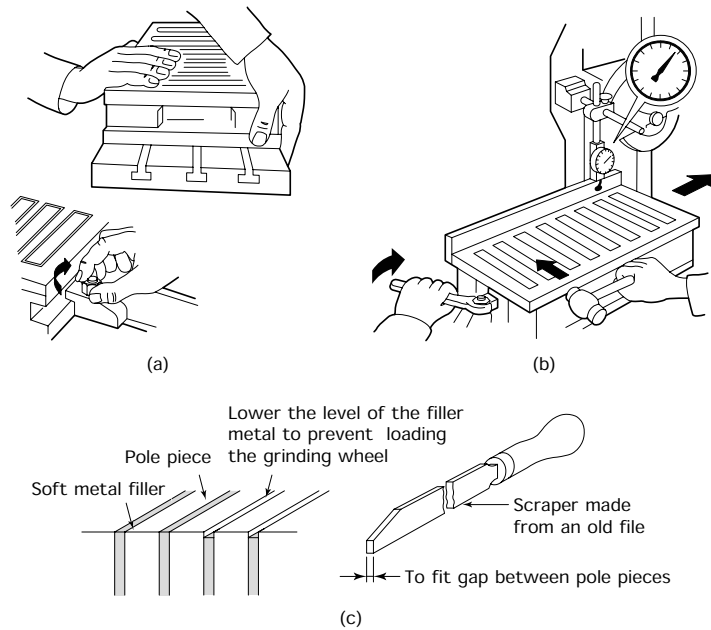


Figure 12.20 *Mounting and setting a magnetic chuck: (a) place the chuck on the machine table and clamp lightly; (b) set parallel to table traverse and tighten clamps; (c) relief of soft filler metal between pole pieces*

- Raise the backplate and, using a DTI as shown in Fig. 12.20(b), set the chuck so that the backplate is parallel to the direction of traverse.
 - Note that the backplate is used as a datum when grinding stepped components.
 - When correctly set the DTI should show a constant reading along the whole length of the backplate.
 - Now tighten the clamps and check again to make sure the chuck hasn't moved.
 - When finally installed the top plate of the chuck should be ground *in situ*. The soft metal filling between the pole pieces will clog the grinding wheel, so remove with a scraper as shown in Fig. 12.20(c). Remove only the minimum amount of filler metal but sufficient so that the level of the filler metal is still *just below* the level of the pole pieces when grinding is complete.
 - Lower or remove the backplate so that the wheel can clear the sides of the chuck whilst initial grinding is taking place.
 - Set the cross-slide and table traverse stops so that the wheel clears each side and end of the chuck. Start up the machine and dress the wheel for rough grinding. That is, traverse the diamond across the face of the wheel rapidly.
 - *Check that the chuck is turned OFF whilst this initial grinding is in progress otherwise grinding dross will accumulate between the pole pieces.*
 - Start the traverse and lower the wheel carefully until it is just touching the high spots on the chuck.
 - Turn on the coolant.
 - Apply a cut of 0.015 mm, engage the cross traverse and grind the top surface of the chuck.
 - Disengage the traverse, stop the machine, turn off the coolant, and examine the chuck. If it is not ground all over, lower the wheel by another 0.015 mm and take another cut. Repeat until the surface of the chuck has been ground all over.
 - Check that the soft filler metal is still below the level of the pole pieces and remove more metal if necessary.
 - Redress the wheel for fine grinding (slow traverse of the diamond across the wheel face). Take a finishing cut of 0.005 mm and check that the whole surface of the chuck is finished ground. Listen to the wheel whilst it is grinding. Any change in, or interruption of, the sound indicates that a further cut may be necessary.
 - Disengage the traverse, stop the machine, and wind the wheel clear of the chuck, remove sharp edges and clean down.
 - The chuck is now ready for use.
-

12.13 Grinding a flat surface

Safety: *Keep your hands and any wipers away from the rapidly revolving wheel at all times.*

12.13.1 Setting up

- Check that the wheel is of a suitable type for the material being cut and the finish required.
- Dress the wheel according to the material being cut and the finish required. Rapid traversing of the diamond produces an 'open' structure for roughing cuts and soft materials. Slow traversing of the diamond produces a 'closed' structure for finishing cuts and hardened materials. It may be necessary to take one or more roughing cuts followed by a finishing cut for final sizing.
- Check the drawing to see which faces are to be ground and the finished size. In this example we are assuming that both faces need to be ground.
- Check the thickness of the work so that you can assess the grinding allowance. Try to arrange the grinding process so that half the allowance is taken from both faces.
- Place the work centrally on the chuck and check for 'rock'.
- If there is any rock due to distortion during hardening or poor initial machining, place non-magnetic shims (paper or thin card) under the work until it seats solidly. Otherwise the chuck may spring the work flat when it is switched on and the work will return to its original shape when the chuck is switched off.
- Make sure that the workpiece covers as many pole pieces as possible and that the chuck is turned ON.
- Set the table and cross-slide traverse stops so that the wheel just clears the work in all directions.

12.13.2 Grinding the first face

- Switch on the machine and start the traverse.
- Hand feed the wheel down carefully until you have visual and audible indications that the wheel is just touching the high spots of the work.
- Turn on the coolant.
- Engage the automatic cross-feed and grind the whole area of the workpiece.
- Stop the traverse, turn off the coolant, and wind the work clear of the grinding wheel using the cross traverse handle.
- Examine the surface of the work. It is unlikely it will have cleaned up all over at this first pass.

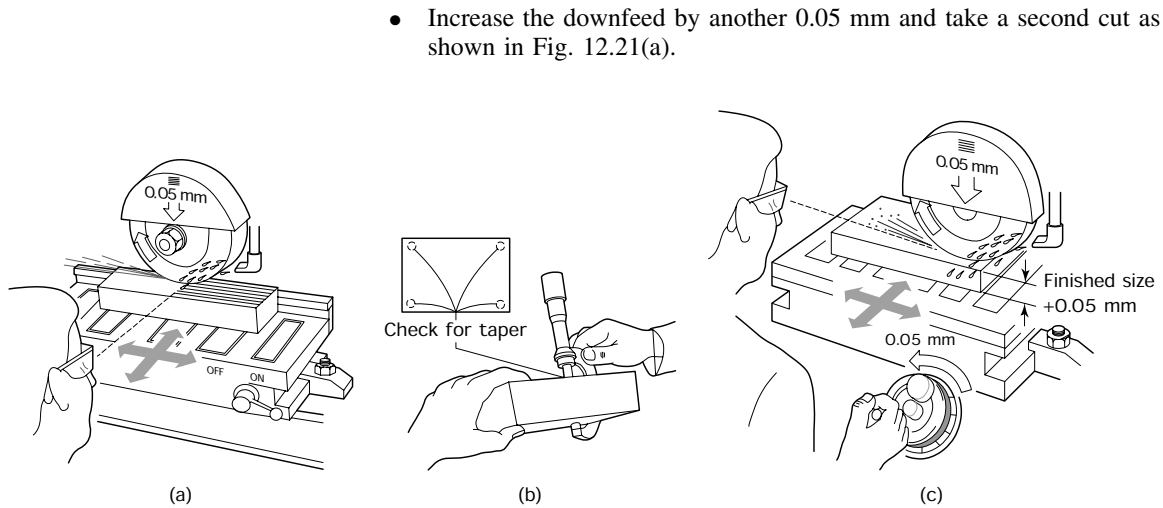


Figure 12.21 Grinding a flat component

- Again wind the work clear of the wheel and examine the surface. When the wheel is cutting all over the surface, stop the machine and prepare to grind the opposite face.
- You should have removed no more than half of the grinding allowance at this stage.

12.13.3 Grinding the second face

- With the machine switched off, turn the chuck off and remove the workpiece and any shims you may have used.
- Clean the workpiece and the surface of the magnetic chuck. Remove any sharp corners.
- Check the thickness of the workpiece so that you can assess the amount of metal that is to be removed as shown in Fig. 12.21(b).
- Replace the work on the chuck. Check for 'rock'. If your first surface is correctly ground there should be no rock unless there is a particle of abrasive between the work and the chuck. Reclean and try again.
- When the work is correctly seated, switch on the chuck and start up the machine.
- Repeat the procedure for the first surface. The second surface should clean up without using up all the grinding allowance. You need some for the finishing cuts (see Fig. 12.21(c)).
- Stop the machine, remove the work and clean the work and the chuck.
- Redress the wheel for finishing using a light cut and traversing the diamond slowly across the wheel.

- Check how much metal is left on the job.
- Replace it on the chuck and take a skim across the first surface.
- Again reverse the work, check the remaining amount of metal to remove.
- Restart the machine and finish to size.
- Switch off the machine, remove and clean the work, remove any sharp corners and clean down the machine.

Safety: *To avoid accidents it has been suggested that you should switch off the machine whilst loading and unloading the work. For trainees this is the safest way to work. However, for some machines this is not possible since they need the wheel spindle to be running continuously to maintain its operating temperature if accurate work is to be produced. In this case the traverse hand wheels must be used to position the work as far from the wheel as possible when loading and unloading the work. Take great care.*

Exercises

12.1 *Safety when using abrasive wheel grinding machines*

- (a) State the requirements of Regulation 9 of the Abrasive Wheel Regulations concerning persons allowed to mount abrasive wheels on grinding machines and the circumstances under which a trainee may change an abrasive wheel.
- (b) Describe the essential differences between an abrasive wheel guard and a milling cutter guard and explain the need for these differences.
- (c) List the defects for which you should check before using an off-hand, double-ended grinding machine to sharpen a chisel or other cutting tool.

12.2 *Abrasive wheels*

- (a) Explain what is meant by the following terms related to abrasive (grinding) wheels:
 - (i) active grains;
 - (ii) grit;
 - (iii) bond;
 - (iv) grade;
 - (v) structure.
- (b) An abrasive wheel carries a British Standard marking of 39C120-K4V. What does this signify? A speed in rev/min should also be marked on the wheel. What does this signify?
- (c) Explain what is meant by the terms *glazing* and *loading* as applied to abrasive wheels. How can these conditions be rectified?
- (d) Explain the essential difference between *dressing* and *truing*. With the aid of sketches describe how these operations may be performed.
- (e) Explain in general terms:

- (i) How the material being ground influences the selection of a suitable grinding wheel.
- (ii) How the rate of stock removal influences the selection of a suitable grinding wheel.
- (f) Precision grinding machines have their abrasive wheels mounted on hubs that contain balance weights.
 - (i) Why do the wheels of precision grinding machines have to be balanced?
 - (ii) Why would a toolroom grinding machine operator keep a variety of wheels available ready mounted and balanced on their hubs.

12.3 Grinding machines

- (a) Sketch a typical pedestal type double-ended, off-hand grinding machine and label its essential features.
- (b) Describe briefly, with the aid of sketches, how a magnetic chuck should be set up on the table of a horizontal spindle, reciprocating table, surface grinding machine and how the chuck should be prepared ready for use.

12.4 Grinding operations

- (a) Describe, with the aid of sketches, how the following jobs should be carried out on a double-ended, off-hand grinding machine.
 - (i) Sharpening a cold chisel and removing any mushrooming from its head.
 - (ii) Regrinding a lathe parting-off tool.
 - (iii) Sharpening a centre punch.
- (b) Describe, with the aid of sketches, how the component shown in Fig. 12.22 can be finished ground all over on a horizontal spindle, reciprocating table, toolroom surface grinding machine.

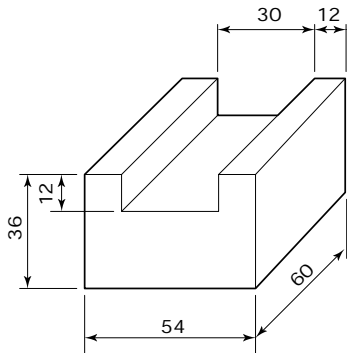


Figure 12.22 Exercise 12.4(b)

This Page Intentionally Left Blank

Index

- Abbreviations, 79
- Accidents, 11
- Accident procedure, 12
- Accuracy, 180
 - effect of force on, 181
 - equipment, accuracy of, 180
 - reading errors, 181
 - temperature, effect of, 180
 - equipment, type of, 181
- Alloy steel, *see* steel
- Aluminium and its alloys, 82
- Angle plates, *see* marking out, tools for providing support
- Angular measurement, *see* measurement
- Annealing, 103
- Appearance, *see* personal protection
- Arbor, *see* milling cutter mounting
- Arsenical tough-pitch copper, 85
- Assembly and dismantling:
 - circlips, 246
 - cotter pins, 246
 - dowels, 245
 - feather key, 246
 - gib-head (tapered) key, 247
 - levers and supports, 247
 - pliers, 244
 - screwdrivers, 243
 - screwed fastenings, 242
 - screwed fastenings, locking devices for, 243
 - spanners and keys, 243
 - taper pins, 245
 - tools used for, 242
 - woodruff key, 247
- Assembly drawing, 143
- Atmosphere control, 118
- Attitude and behaviour, 42

- Bar charts, 53
- Basic relationships, 38
- Behaviour in workshops, 22

- Bench fitting:
 - chipping, 224
 - files, care of, 230
 - files, types of, 227
 - files, use of, 229
 - filing, 227
 - filing, safety when, 231
 - hacksaw, the, 231
 - hacksawing, hints when, 232
 - hammers, 226
- Bevel protractor (plain), *see* measurement
- Bevel protractor (vernier), *see* measurement
- Bowline, 32
- Box square, *see* marking out tools providing guidance
- Boring, 314
- Brass alloys, 85
- British standards for wrought steels, 80
- Brittleness, *see* materials, properties of
- Bronze (tin) alloys, 85
- Bruises, *see* first aid
- Burns and scalds, *see* first aid

- Calipers, *see* measurement
- Calipers (vernier), *see* measurement
- Carriage (saddle), *see* centre lathe
- Case hardening, 105
- Cast iron, 79
- Cathode copper, 82
- Centre punch, *see* marking out equipment
- Centre punch, sharpening, 393
- Ceramics, 89
- Centre lathe:
 - apron, 287
 - bed, 285
 - boring, single-point, 314
 - camlock spindle, 293
 - carriage, 287

- Centre lathe: (*continued*)
 - chuck guard, 283
 - compound-slide, 287
 - concentricity, 309
 - constructional features of the, 285
 - cross-slide, 287
 - drilling on the, 313
 - end-train gears, 289
 - feed gearbox, 288
 - fixed steady, use of a, 309
 - headstock (fixed head), 286
 - hole production, 312
 - knurling, 318
 - main movements and alignments, 289
 - plain nose spindle, 292
 - revolving centre, 297
 - saddle, 287
 - safe use of a, 281
 - shutting down the machine, 294
 - starting up the machine, 294
 - tailstock (loose head), 286
 - taper-nose spindle (long), 292
 - taper-nose spindle (short), 293
 - tool posts, 287
 - tool profiles, 309
 - travelling guard, 284
 - travelling steady, use of a, 307
- Centre lathe operations:
 - centres, work between, 330
 - cutting forces, 327
 - cutting speeds as applied to, 328
 - cylindrical (parallel) turning, 325
 - faceplate, work on a, 335
 - four-jaw chuck, work held in a, 334
 - parallel mandrel (snug), work held on a, 333
 - perpendicular turning, 327
 - parting-off, 315
 - reaming, 314
 - screw thread (external), production of, 316
 - screw thread (internal), production of, 317
 - taper mandrel, work held on a, 332
 - taper turning, 310
 - three-jaw self-centring chuck, work held in a, 332
- Centre lathe work holding devices:
 - centres, 295
 - face plate, 306
 - four-jaw independent chuck, 303
 - parallel mandrel (snug), 333
 - taper mandrel, 298
 - three-jaw self-centring chuck, 300
- Checking the link, 252
- Chipping, *see* bench fitting
- Chisels, sharpening, 392
- Chromium, 76
- Circlips, *see* assembly and dismantling
- Clearance angle, *see* metal cutting wedge
- Climb milling, *see* milling, down-cut,
- Clothing, *see* personal protection
- Clove hitch, 31
- Cobalt, 77
- Cold-working (of metals), 71
- Cold-working processes, 72
- Combination set, *see* marking out, tools providing guidance
- Communications, 44
 - colour coding, 61
 - posters, 62
 - safety and hazard notices, 60
 - safety and hazard signs, 60
- Company policy
 - health, safety and personal hygiene, 43
 - implementation of, 43
- Compound-slide, use of for taper turning, 312
- Compressive strength, *see* properties of materials
- Computer files, 59
- Concentricity, 175
- Conductivity (heat), 69
- Confrontation, 39
- Conventional milling, *see* milling, up-cut,
- Conventions (drawing), 129
- Coolants, 322

- Co-operation, 39
Co-ordinates, 202
Co-ordinates (polar), 203
Co-ordinates (rectangular), 202
Copper and copper alloys, 82
 arsenical tough pitch and phosphorus deoxidised copper, 85
 brass (copper and zinc alloy), 85
 bronze (copper and tin alloy), 85
 cathode copper, 82
 high conductivity copper, 82
 phosphorus deoxidised, non-arsenical copper, 85
 tough pitch copper, 82
Corrosion resistance, *see* properties of materials
Corundum, 88
Cotter pins, *see* assembly and dismantling
Counterboring, *see* drilling processes
Countersinking, *see* drilling processes
Creating effective relationships:
 positive attitudes, 46
 personal property, respect for, 47
 teamwork, 46
Cutter guards, 24
Cutting external screw threads, use of dies, 239
Cutting lubricants, 322
 soluble oils, 323
Cutting tools (lathe) – tool height, 323
Cylinder gauge, *see* measurement

Datum, types of, 201
Deep-case hardening, 107
Depth micrometer, *see* measurement
Detail drawings, 143
Dial test indicator (DTI), *see* measurement
Die nuts, 240
Dividers, *see* marking-out equipment
Dividing head (simple indexing), 361
Dot punch, *see* marking-out equipment
Dot punch – sharpening, 393
Double-ended off-hand grinding machine, 389
Dowels, *see* assembly and dismantling
Drawings and diagrams, 57
Drilling machines:
 basic alignments of, 275
 pillar type, 277
 sensitive bench type, 276
 tool holding, 270
 workholding, 272
 workholding (cylindrical workpieces), 275
 workholding (drilling jigs), 275
 workholding (rectangular workpieces), 272
Drilling processes:
 counterboring, 269
 countersinking, 268
 reamers and reaming, 266
 spot facing, 269
 trepanning, 268
Ductility, *see* properties of materials

Edge datum, *see* datum, types of,
Elasticity, *see* properties of materials
Electrical hazards, *see* health hazards, electrical
Emery, 88
Employers' responsibilities, *see* Health and Safety Executive
Employees' responsibilities, *see* Health and Safety Executive
Engineering drawings:
 abbreviations for written statements, 131
 auxiliary dimensions, 136
 conventions, 129, 132
 detail drawings, 143
 dimensioning (general), 134
 dimensioning (diameters and radii), 135

- Engineering drawings: (*continued*)
 - exploded (assembly) drawings, 143
 - first-angle orthographic, 124
 - general arrangement drawings, 142
 - introduction, 123
 - isometric projection, 145
 - leader lines, 136
 - machining symbols, 140
 - oblique projection, 145
 - pictorial views, 144
 - redundant views, 133
 - sectioning, 138
 - sketching (orthographic), 147
 - sketching (pictorial), 147
 - third-angle orthographic projection, 127
 - toleranced dimensions, 137
 - types of, 141
 - types of line, 129
- Engineering information:
 - evaluation of, 57
 - health and safety, 58
 - legal and financial, 58
 - quality control, 58
 - reading and processing, 58
- Eye, foreign bodies in the, 15
- Eyebolts, 31
- Face plate, *see* centre lathe workholding devices
- Feather key, *see* assembly and dismantling
- Ferrous metals, 73, 76
- Fibre ropes, knots for, 31
- Files, care of, *see* bench fitting
- Files, types of, *see* bench fitting
- Files, use of, *see* bench fitting
- Filing, *see* bench fitting
- Fire extinguishers, 8
 - carbon dioxide (CO₂), 8
 - dry powder, 9
 - foam, 8
 - vaporising liquid, 9
 - water, 8
- Fire fighting, 7
 - general rules governing the use of portable extinguishers, 9
- Fire precautions, 10
- Fire prevention, 10
- First angle orthographic drawing, 124
- First aid, 14
 - bruises, 15
 - in the event of an emergency, 14
 - minor burns and scalds, 15
 - minor wounds, 14
- Fits, classes of, *see* limits and fits
- Fitter's bench, 219
- Fitter's vice, 219
- Flatness, 175
- Foot protection, *see* personal protection, feet,
- Forms of supply (materials), 92
- Four-jaw chuck, *see* centre lathe workholding devices
- Further legislation and regulations concerning safety, 3
- Fusibility, *see* properties of metals
- Gang milling, 355
- Gauging – taper plug and ring gauges, 173
- General arrangement drawings, 142
- Gib-head key, *see* assembly and dismantling
- Glass, 88
- Grinding:
 - abrasive wheels, misuse of, 378
 - eye protection, 379
 - flat surfaces, 400
 - fundamental principles of, 379
 - guards, 377
 - safety, 376
 - selection of wheels, 378
 - spindle speeds, 378
 - truing and dressing, 378
 - wheel speeds, 377
- Grinding machine:
 - double-ended off-hand, 389
 - surface grinding, 393
- Grinding processes – sharpening hand tools and single point cutting tools, 392
- Grinding wheel:
 - abrasive, 381
 - balancing, 387

- bond, 383
- diamond wheel dresser, 387
- dressing and truing, 386
- dressing stick, 387
- grade, 382
- grain size (grit size), 382
- huntington type wheel dresser, 386
- specification, 380
- structure, 382
- Grinding wheel defects:
 - glazing, 386
 - loading, 385
 - damage, 386
- Grinding wheel selection:
 - bond, 384
 - grinding machine, type of, 385
 - material to be ground, 384
 - stock removal, rate of, 386
 - wheel speed, 385
- Guards (cutter), 24
- Gun-metal (bronze alloy), 85
- Hair (long), *see* personal protection
- Half hitch, 31
- Hammers, *see* bench fitting
- Hacksaw, *see* bench fitting
- Hand protection, *see* personal protection
- Hand tools, application of basic cutting angles to,
 - cold chisel, 223
 - files, 223
 - hacksaw blades, 223
- Hand tools:
 - hazards associated with, 22
 - preparation of, 248
 - use of, relative merits and disadvantages, 219
- Hardness, *see* properties of materials
- Hazards:
 - electrical, 6
 - fire, 7
 - hand tools, 22
 - health, 20
 - health (irritant effects), 21
 - health (noise), 20
 - health (systemic effects), 21
 - health (narcotic effects), 20
 - machine tools, 23
- Health and Safety at Work, etc., Act, 1
- Health and Safety Commission, 1
- Health and Safety Executive, 2
 - employers' responsibilities, 3
 - employees' responsibilities, 5
 - improvement notices, 2
 - prohibition notices, 2
 - prosecution, 2
- Head and eye protection, 17
- Heat conductivity, *see* properties of materials
- Heat treatment:
 - atmosphere control, 118
 - definitions, 94
 - furnaces, 110
 - non-ferrous metal and alloys, 109
- Heat treatment of plain carbon steels:
 - annealing (full), 103
 - annealing (stress-relief), 103
 - case hardening, 105
 - case hardening (deep), 107
 - case hardening (localised), 108
 - case hardening (superficial), 106
 - hardening, through (quench), 97
 - normalizing, 104
 - quenching, distortion and cracking when, 99
 - tempering, 102
- Heat treatment processes:
 - fire precautions, 96
 - gloves, 95
 - headwear, goggles and visors, 95
 - introduction, 94
 - protective clothing, 95
 - safety, 94
 - safety notices, 96
 - safety shoes and boots, 95
- Hermaphrodite calipers, *see* marking out equipment
- High carbon steel, *see* steel
- High conductivity copper, *see* copper and copper alloys
- High speed steel, *see* steel

- Histograms, 52
- Horizontal spindle milling
 - machine, 346
- Hot-working (metals), 71
- Hot-working processes, 72
- Hygiene, personal, 22
- Identification of metals, workshop
 - tests for, 87
- Improvement notice, *see* Health and safety Executive
- Indicated size, 183
- Information, interpretation of,
 - bar charts, 53
 - British and European Standards, 54
 - graphical, 51
 - histograms, 52
 - ideographs (pictograms), 53
 - line graphs, 51
 - manufacturers' catalogues, 54
 - pie charts, 54
- Information sources, 50
- Internal micrometer, *see* measurement
- Irritant effects, 21
- Isometric projection, 145
- Knots for fibre ropes, 31
- Knurling, 318
- Lathe tools:
 - chip breaker, 322
 - chip formation, 319
 - chip formation (continuous with built-up edge), 319
 - chip formation (discontinuous), 318
 - chip welding, prevention of, 320
 - geometry of, 321
 - profiles of, 309
- Levers, *see* assembly and dismantling
- Lifting, 27
- Lifting accessories:
 - eye-bolts and shackles, 31
 - rings, 30
- Lifting equipment, 28
 - inspection of, 33
 - mechanical, 27
 - slings, 29
 - use of, 27
- Limits and fits, 177
 - classes of fit, 179
- Line datum, *see* datum,
 - types of,
- Line graphs, 51
- Localised case-hardening, 108
- Long arbor, mounting a milling cutter on a, 353
- Loop, single, 31
- Loose dies, rectangular, 240
- Low-carbon steel, *see* steel
- Lowering a load, 28
- Machine vice (plain), 357
- Machine vice (swivel base), 358
- Machine tool hazards, 23
- Magnetic chuck, 395
- Making a link, 249
- Malleability, *see* properties of materials
- Mandatory signs, 13
- Manganese, 77
- Manual lifting (individual), 25
- Manual lifting (team), 25
- Manufacturer's catalogues, 54
- Marking out:
 - cutting and limit lines, 212
 - faults and inaccuracies, causes of, 211
 - guide lines, 213
 - line enhancement, 214
 - manual, advantages and disadvantages of, 200
 - round holes, size and position, 212
 - witness lines, 214
- Marking out equipment:
 - centre punch, 188
 - condition and care of, 210
 - dividers and trammels, 191
 - dot punch, 188
 - hermaphrodite calipers, 192
 - scriber, 188
 - scribing block (surface gauge), 192
 - vernier height gauge, 193
- Marking out, techniques for:
 - line datum, use of, 204

- mutually perpendicular datum
 - edges, use of, 206
- point datum and tabulated data, use of, 208
- single edge datum, use of, 205
- surface preparation, 203
- Marking out tools for providing guidance:
 - box square, 194
 - combination set, 195
 - rule and straight edge, 194
 - try square, 194
- Marking out tools for providing support:
 - angle plates, 197
 - jacks, wedges and shims, 199
 - parallels, 199
 - surface plates and tables, 197
 - vee blocks, 199
- Materials:
 - classification of, 73
 - forms of supply, 92
- Measurement:
 - angular, 170
 - bevel protractor (plain), 171
 - bevel protractor (vernier), 171
 - calipers and their use, 158
 - depth micrometer, 164
 - dial test indicator (DTI), 166
 - internal micrometer, 162
 - linear, 156
 - line and end, 157
 - micrometer caliper
 - (construction and use of), 162
 - micrometer caliper (care of), 159
 - micrometer cylinder gauge, 162
 - right angles, 170
 - sine-bar, 176
 - slip gauges, 168
 - steel rule (care of), 157
 - steel rule (use of), 156
 - terminology of, 183
 - try square, 170
 - vernier caliper, 164
 - vernier protractor, 171
- Measuring accuracy, 183
- Measuring equipment, correct use of, 182
- Measuring range, 183
- Mechanical lifting equipment, 27
- Medium carbon steels, *see* steel
- Metals, 73
- Metal cutting wedge, 220
 - clearance angle, 221
 - rake angle, 222
 - wedge angle, 221
- Microfilm, 60
- Micrometer, *see* measurement
- Milling cutter mounting:
 - collet chuck, 357
 - long arbor, 352
 - stub arbor, 355
 - vertical machine, 355
- Milling machine cutters
 - (horizontal machine), 350
- Milling machine cutters (vertical machine), 350
- Milling machine
 - cutting speeds and feeds, 362
 - horizontal spindle, 346
 - horizontal spindle, basic
 - movements and alignments, 347
 - safety, 342
 - vertical spindle, 347
 - vertical spindle, basic
 - movements and alignments, 347
 - work holding (direct mounting), 360
 - work holding (dividing head), 361
 - work holding (machine vice, plain), 358
 - work holding (machine vice, swivel base), 357
- Milling processes, 343
 - angular surfaces, 369
 - cutting a slot (horizontal spindle machine), 368
 - cutting a step (horizontal spindle machine), 367
 - cutting a step (vertical spindle machine), 368
 - squaring up a blank (horizontal spindle machine), 365

- Milling techniques
 - down-cut (climb), 346
 - up-cut (conventional), 345
- Molybdenum, 76
- Narcotic (anaesthetic) effects, *see*
 - hazards, health,
- Nickel, 76
- Noise, *see* hazards, health,
- Non-ferrous metals and alloys, 81
 - heat treatment of, annealing, 109
 - heat treatment of, precipitation treatment, 110
 - heat treatment of, solution treatment, 109
- Non-metallic materials, 73
 - natural, 87
 - synthetic, 89
- Normalizing, 104
-
- Oblique projection, 145
-
- Parallelism, 175
- Parallels, *see* marking out tools
 - providing support
- Parting off, 315
- Personal hygiene, 22
- Personal protection:
 - appearance, 16
 - buttons missing and loose cuffs, hazards of, 17
 - clothing, 16
 - feet (footwear), 20
 - hands, 18
 - holes in pockets, 17
 - lightweight shoes, hazards of, 17
 - long hair, hazards of, 16
 - overalls too long, 17
 - sharp tools, 17
- Personal property, respect for, 47
- Phosphor bronze alloys, 85
- Phosphorous deoxidised copper, 85
- Pictograms (ideographs), 53
- Pictorial views, 144
- Pie charts, 54
- Plain carbon steel, *see* steel
- Plain carbon steel, heat treatment
 - of, *see* heat treatment of plain carbon steel
- Plasticity, *see* properties of materials
- Plastics, thermo, 90
- Plastics, thermosetting, 90
- Pliers, *see* assembly and dismantling
- Point datum, *see* datum, types of
- Positive attitude, 46
- Precipitation treatment, 110
- Preserving scribed lines, 212
- Product specification, 55
- Production schedule, 55
- Profiles (radius gauge), 177
- Profiles (template, use of,) 177
- Prohibition notice, *see* Health and Safety Executive
- Prohibition signs, 12
- Properties of materials:
 - brittleness, 67
 - corrosion resistance, 71
 - compressive strength, 67
 - ductility, 69
 - elasticity, 68
 - fusibility, 70
 - hardness, 69
 - heat conductivity, 69
 - malleability, 69
 - plasticity, 68
 - refractoriness, 70
 - rigidity, 68
 - shear strength, 67
 - tensile strength, 66
 - toughness, 67
- Prosecution, *see* Health and Safety Executive
-
- Quenching, 99
-
- Rake angle, *see* metal cutting
 - wedge
- Reading (measurement), 183
- Reading people, 40
- Reading value (measurement), 183
- Reamer (hand), 241
- Reamer (machine), 266
- Reamer (taper pin), 241
- Reaming, 241

- Recording and filing, 43
Record keeping, methods of,
 computer files, 59
 microfiche, 60
 microfilm, 60
 logbooks, 60
 registers, 60
Recrystallisation, 71
Reef knot, 31
Reference tables and charts, 57
Refractoriness, *see* properties of
 materials
Relationships, 38
 attitudes and behaviour, 42
 with instructors, 40
 with managers, 40
 with supervisors, 40
Revolving tailstock, 297
Rigidity, *see* properties of
 materials
Rings, 30
Roundness, 177
Rubber, 88
- Saddle (carriage), *see* centre lathe
Safe condition signs, 14
Safety when filing, 231
Sawing of sheet metal, 233
Screwdrivers, *see* assembly and
 dismantling
Screw threads, applications of,
 233, 235
 elements, 234
 specification of, 234
Screw thread form:
 British Association (BA), 235
 ISO metric, 235
 unified, 235
 Whitworth, 235
Screw thread dies, 239
 hints when using, 240
Screw thread taps, 236
 hints when using, 236
Scriber, *see* marking out
 equipment
Scribing block, *see* marking out
 equipment
Shackles, 31
Sharp tools, *see* personal
 protection
- Shoes, lightweight, *see* personal
 protection
Sine-bar, *see* measurement
Single-point tools, sharpening,
 393
Sketching, 147
Slings, 29
Slip gauges, *see* measurement
Snug (parallel mandrel) use of,
 333
Soluble oils, 323
Solution treatment, 109
Spanners and keys, *see* assembly
 and dismantling
Spindle noses, types of, *see* centre
 lathe
Spot facing, 269
Steadies, *see* centre lathe
Steel:
 alloy, 76
 high carbon, 76
 high-speed, 77
 low carbon, 75
 medium carbon, 75
 plain carbon, 74
 stainless, 77
Steel rule, *see* measurement
Standards, British and European,
 54
States of matter, 65
Straddle milling, 355
Straight edge, *see* marking out
 tools providing guidance
Stub arbor, *see* milling cutter
 mounting
Superficial case-hardening, 106
Surface datum, *see* datum,
 types of,
Surface grinding machine, 393
Surface grinding:
 magnetic chuck – mounting on
 the worktable, 398
 workholding – magnetic chuck,
 395
 workholding – mechanical
 clamping, 397
Surface plates and tables, *see*
 marking out tools providing
 support

- Systemic effects, *see* hazards, health,
- Tailstock offset, 311
- Taper pins, *see* assembly and dismantling
- Taper plug gauges, *see* gauging
- Taper ring gauges, *see* gauging
- Taper turning, *see* centre lathe
- Taper turning attachment, 311
- Tapping holes, hints when, 238
- Teamwork, 46
- Temperature assessment:
 - paints and crayons for, 118
 - ceramic (seger) cones, 118
- Temperature measurement:
 - radiation pyrometer, 117
 - thermocouple pyrometer, 115
- Tempering, 102
- Tensile strength, *see* properties of materials
- Thermoplastics, 90
- Thermosetting plastics, 90
- Third angle orthographic drawing, 127
- Thread cutting devices,
 - miscellaneous, 240
- Three-jaw chuck, *see* centre lathe
- Tin-bronze alloys, 85
- Tolerance, *see* limits and fits
- Toughness, *see* properties of materials
- Tough-pitch copper, 82
- Trammels, *see* marking out equipment
- Transmission guards, 24
- Transporting loads, 32
- Trepanning, 268
- Trucks, 32
- Try square, *see* Marking out tools
 - providing guidance, also *see* measurement
- Tungsten, 77
- Turning operations, *see* centre lathe operations
- Twist drills, 257
 - blind hole drilling, 265
 - cutting angles, 259
 - cutting speeds and feeds, 260
 - failures and faults, 263
 - sharpening, 398
- Vee-blocks, 199, 275
- Vernier calipers, 164
- Vernier height gauge, 193
- Vertical spindle milling machine, 347
- Vice shoes, 220
- Vice, use of, 220
- Warning signs and labels, 12
- Wedge angle, *see* metal cutting wedge
- Witness lines, 214
- Wood, 89
- Workshop tests for the
 - identification of metals, 87
- Wrought steels, British Standards for, 80