

---

# **SIMPLIFIED MECHANICS AND STRENGTH OF MATERIALS**

---

Sixth Edition

**JAMES AMBROSE**

*Formerly Professor of Architecture  
University of Southern California  
Los Angeles, California*

based on the work of

*THE LATE HARRY PARKER  
Formerly Professor of Architectural Construction  
University of Pennsylvania*



**JOHN WILEY & SONS, INC.**

---



**SIMPLIFIED MECHANICS  
AND STRENGTH OF MATERIALS**

Other titles in the  
**PARKER-AMBROSE SERIES OF SIMPLIFIED DESIGN GUIDES**

*Harry Parker, John W. MacGuire and James Ambrose*  
Simplified Site Engineering, 2nd Edition

*James Ambrose*  
Simplified Design of Building Foundations, 2nd Edition

*James Ambrose and Dimitry Vergun*  
Simplified Building Design for Wind and Earthquake Forces, 3rd Edition

*James Ambrose*  
Simplified Design of Masonry Structures

*James Ambrose and Peter D. Brandow*  
Simplified Site Design

*Harry Parker and James Ambrose*  
Simplified Mechanics and Strength of Materials, 5th Edition

*Marc Schiler*  
Simplified Design of Building Lighting

*James Patterson*  
Simplified Design for Building Fire Safety

*William Bobenhausen*  
Simplified Design of HVAC Systems

*James Ambrose*  
Simplified Design of Wood Structures, 5th Edition

*James Ambrose and Jeffrey E. Ollswang*  
Simplified Design for Building Sound Control

*James Ambrose*  
Simplified Design of Building Structures, 3rd Edition

*James Ambrose and Harry Parker*  
Simplified Design of Concrete Structures, 7th Edition

*James Ambrose and Harry Parker*  
Simplified Design for Steel Structures, 7th Edition

*James Ambrose*  
Simplified Engineering for Architects and Builders, 9th Edition

---

# **SIMPLIFIED MECHANICS AND STRENGTH OF MATERIALS**

---

Sixth Edition

**JAMES AMBROSE**

*Formerly Professor of Architecture  
University of Southern California  
Los Angeles, California*

based on the work of

*THE LATE HARRY PARKER  
Formerly Professor of Architectural Construction  
University of Pennsylvania*



**JOHN WILEY & SONS, INC.**

---

Copyright © 2002 by John Wiley & Sons, New York. All rights reserved.

No part of this publication may be reproduced, stored in a retrieval system or transmitted in any form or by any means, electronic, mechanical, photocopying, recording, scanning or otherwise, except as permitted under Sections 107 or 108 of the 1976 United States Copyright Act, without either the prior written permission of the Publisher, or authorization through payment of the appropriate per-copy fee to the Copyright Clearance Center, 222 Rosewood Drive, Danvers, MA 01923, (978) 750-8400, fax (978) 750-4744. Requests to the Publisher for permission should be addressed to the Permissions Department, John Wiley & Sons, inc., 605 Third Avenue, New York, NY 10158-0012, (212) 850-6011, fax (212) 850-6008, E-Mail: PERMREQ @ WILEY.COM.

This publication is designed to provide accurate and authoritative information in regard to the subject matter covered. It is sold with the understanding that the publisher is not engaged in rendering professional services. If professional advice or other expert assistance is required, the services of a competent professional person should be sought.

This title is also available in print as ISBN 0-471-40052-1 [print version ISBN/s--include cloth and paper ISBNs, if both are available]. Some content that appears in the print version of this book may not be available in this electronic edition.

For more information about Wiley products, visit our web site at [www.Wiley.com](http://www.Wiley.com)

---

# CONTENTS

---

<b>Preface to the Sixth Edition</b>	<b>ix</b>
<b>Preface to the First Edition</b>	<b>xiii</b>
<b>Introduction</b>	<b>1</b>
Structural Mechanics / 2	
Units of Measurement / 2	
Accuracy of Computations / 3	
Symbols / 7	
Nomenclature / 7	
<b>1 Structures: Purpose and Function</b>	<b>9</b>
1.1 Loads / 11	
1.2 Special Considerations for Loads / 13	
1.3 Generation of Structures / 21	
1.4 Reactions / 24	
1.5 Internal Forces / 28	
1.6 Functional Requirements of Structures / 30	

1.7	Types of Internal Force / 39	
1.8	Stress and Strain / 46	
1.9	Dynamic Effects / 61	
1.10	Design for Structural Response / 64	
<b>2</b>	<b>Forces and Force Actions</b>	<b>69</b>
2.1	Loads and Resistance / 69	
2.2	Forces and Stresses / 71	
2.3	Types of Forces / 73	
2.4	Vectors / 73	
2.5	Properties of Forces / 74	
2.6	Motion / 76	
2.7	Force Components and Combinations / 78	
2.8	Graphical Analysis of Forces / 83	
2.9	Investigation of Force Actions / 87	
2.10	Friction / 91	
2.11	Moments / 97	
2.12	Forces on a Beam / 102	
<b>3</b>	<b>Analysis of Trusses</b>	<b>111</b>
3.1	Graphical Analysis of Trusses / 111	
3.2	Algebraic Analysis of Trusses / 120	
3.3	The Method of Sections / 127	
<b>4</b>	<b>Analysis of Beams</b>	<b>132</b>
4.1	Types of Beams / 133	
4.2	Loads and Reactions / 134	
4.3	Shear in Beams / 135	
4.4	Bending Moments in Beams / 140	
4.5	Sense of Bending in Beams / 147	
4.6	Cantilever Beams / 151	
4.7	Tabulated Values for Beam Behavior / 155	
<b>5</b>	<b>Continuous and Restrained Beams</b>	<b>160</b>
5.1	Bending Moments for Continuous Beams / 160	
5.2	Restrained Beams / 172	



5.3	Beams with Internal Pins / 176	
5.4	Approximate Analysis of Continuous Beams / 181	
<b>6</b>	<b>Retaining Walls</b>	<b>183</b>
6.1	Horizontal Earth Pressure / 184	
6.2	Stability of Retaining Walls / 186	
6.3	Vertical Soil Pressure / 188	
<b>7</b>	<b>Rigid Frames</b>	<b>192</b>
7.1	Cantilever Frames / 193	
7.2	Single-Span Frames / 199	
<b>8</b>	<b>Noncoplanar Force Systems</b>	<b>202</b>
8.1	Concurrent Systems / 203	
8.2	Parallel Systems / 209	
8.3	General Noncoplanar Systems / 213	
<b>9</b>	<b>Properties of Sections</b>	<b>214</b>
9.1	Centroids / 215	
9.2	Moment of Inertia / 218	
9.3	Transferring Moments of Inertia / 223	
9.4	Miscellaneous Properties / 228	
9.5	Tables of Properties of Sections / 229	
<b>10</b>	<b>Stress and Deformation</b>	<b>239</b>
10.1	Mechanical Properties of Materials / 241	
10.2	Design Use of Direct Stress / 243	
10.3	Deformation and Stress: Relations and Issues / 246	
10.4	Inelastic and Nonlinear Behavior / 251	
<b>11</b>	<b>Stress and Strain in Beams</b>	<b>254</b>
11.1	Development of Bending Resistance / 255	
11.2	Investigation of Beams / 259	
11.3	Computation of Safe Loads / 261	
11.4	Design of Beams for Flexure / 263	
11.5	Shear Stress in Beams / 265	
11.6	Shear in Steel Beams / 270	

11.7	Flitched Beams / 272	
11.8	Deflection of Beams / 275	
11.9	Deflection Computations / 279	
11.10	Plastic Behavior in Steel Beams / 283	
<b>12</b>	<b>Compression Members</b>	<b>293</b>
12.1	Slenderness Effects / 293	
12.2	Wood Columns / 297	
12.3	Steel Columns / 301	
<b>13</b>	<b>Combined Forces and Stresses</b>	<b>309</b>
13.1	Combined Action: Tension Plus Bending / 309	
13.2	Combined Action: Compression Plus Bending / 312	
13.3	Development of Shear Stress / 318	
13.4	Stress on an Oblique Section / 319	
13.5	Combined Direct and Shear Stresses / 321	
<b>14</b>	<b>Connections for Structural Steel</b>	<b>324</b>
14.1	Bolted Connections / 324	
14.2	Design of a Bolted Connection / 337	
14.3	Welded Connections / 343	
<b>15</b>	<b>Reinforced Concrete Beams</b>	<b>353</b>
15.1	General Considerations / 353	
15.2	Flexure: Stress Method / 363	
15.3	General Application of Strength Methods / 375	
15.4	Flexure: Strength Method / 376	
15.5	T-Beams / 382	
15.6	Shear in Concrete Beams / 387	
15.7	Design for Shear in Concrete Beams / 394	
	<b>References</b>	<b>402</b>
	<b>Answers to Selected Exercise Problems</b>	<b>403</b>
	<b>Index</b>	<b>409</b>

---

# PREFACE TO THE SIXTH EDITION

---

Publication of this book presents the opportunity for yet another new generation of readers to pursue a study of the fundamental topics that underlie the work of design of building structures. In particular, the work here is developed in a form to ensure its accessibility to persons with limited backgrounds in engineering. That purpose and the general rationale for the book are well presented in Professor Parker's preface to the first edition, excerpts from which follow.

The fundamental materials presented here derive from two general areas of study. The first area is that of *applied mechanics*, and most principally, applications of the field of *statics*. This study deals primarily with the nature of forces and their effects when applied to objects. The second area of study is that of *strength of materials*, which deals generally with the behavior of particular forms of objects, of specific structural materials, when subjected to actions of forces. Fundamental relationships and evaluations derived from these basic fields provide the tools for investigation of structures relating to their effectiveness and safety for usage in building construction. No structural design work can be satisfactorily achieved without this investigation.

In keeping with the previously stated special purpose of this book, the work here is relatively uncomplicated and uses quite simple mathematics. A first course in algebra plus some very elementary geometry and trigonometry will suffice for the reader to follow any derivations presented here. In fact, the mathematical operations in applications to actual problem solving involve mostly only simple arithmetic and elementary algebra.

More important to the study here than mechanical mathematical operations is the conceptual visualization of the work being performed. To foster this achievement, extensive use is made of graphic images to encourage the reader to literally *see* what is going on. The ultimate extension of this approach is embodied in the first chapter, which presents the entire scope of topics in the book without mathematics. This chapter is new to this edition and is intended both to provide a comprehensive grasp of the book's scope and to condition the reader to emphasize the need for visualization preceding any analytical investigation.

Mastery of the work in this book is essentially preparatory in nature, leading to a next step that develops the topic of structural design. This step may be taken quite effectively through the use of the book that is essentially a companion to this work: *Simplified Engineering for Architects and Builders*. That book picks up the fundamental materials presented here, adds to them various pragmatic considerations for use of specific materials and systems, and engages the work of creating solutions to structural design problems.

For highly motivated readers, this book may function as a self-study reference. Its more practical application, however, is as a text for a course in which case readers will have the advantage of guidance, prodding, and counsel from a teacher. For teachers accepting such a challenge, a *Teacher's Manual* is available from the publisher.

While the work here is mostly quite theoretical in nature, some use of data and criteria derived from sources of real materials and products is necessary. Those sources consist primarily of industry organizations, and I am grateful for the permissions granted for such use. Primary sources used here include the American Concrete Institute, the American Institute for Steel Construction, and the American Forest and Paper Association.

A practical context for this theoretical work is presented through several illustrations taken from books that more thoroughly develop the topic of building construction. I am grateful to John Wiley & Sons for

permission to use these illustrations from several of its publications, both current and vintage works.

Bringing any work to actual publication requires enormous effort and contributions by highly competent and experienced people who can transform the author's raw materials into intelligible and presentable form. Through many engagements, I continue to be amazed at the level of quality and the skill of the editors and production staff at John Wiley & Sons who achieve this effort.

This work is the sixtieth publication that I have brought forth over the past 35 years, all of which were conceived and produced in my home office. None of them—first to last—would have happened there without the support, encouragement, and lately the direct assistance of my wife, Peggy. I am grateful to her for that contribution, and hope she will sustain it through the next work.

JAMES AMBROSE

2002



---

# PREFACE TO THE FIRST EDITION

---

*The following are excerpts from the preface to the first edition of this book, written by Professor Parker at the time of publication in 1951.*

Since engineering design is based on the science of mechanics, it is impossible to overemphasize the importance of a thorough knowledge of this basic subject. Regardless of the particular field of engineering in which a student is interested, it is essential that he understand fully the fundamental principles that deal with the actions of forces on bodies and the resulting stresses.

This is an elementary treatment written for those who have had limited preparation. The best books on the subject of mechanics and strength of materials make use of physics, calculus, and trigonometry. Such books are useless for many ambitious men. Consequently, this book has been prepared for the student who has not obtained a practical appreciation of mechanics or advanced mathematics. A working knowledge of algebra and arithmetic is sufficient to enable him to comprehend the mathematics involved in this volume.

This book has been written for use as a textbook in courses in mechanics and strength of materials and for use by practical men interested in mechanics and construction. Because it is elementary, the material has been arranged so that it may be used for home study. For those who have had previous training it will serve as a refresher course in reviewing the most important of the basic principles of structural design.

One of the most important features of this book is a detailed explanation of numerous illustrative examples. In so far as possible, the examples relate to problems encountered in practice. The explanations are followed by problems to be solved by the student.

This book presents no short-cuts to a knowledge of the fundamental principles of mechanics and strength of materials. There is nothing unique in the presentation, for the discussions follow accepted present-day design procedure. It is the belief of the author, however, that a thorough understanding of the material contained herein will afford a foundation of practical information and serve as a step to further study.

HARRY PARKER

*High Hollow  
Southampton  
Bucks County, Pennsylvania  
May 1951*



---



---

# INTRODUCTION

---

The principal purpose of this book is to develop the topic of *structural investigation*, also sometimes described as *structural analysis*. To the extent possible, the focus of this study is on a consideration of the analytical study as a background for work in structural design. The work of structural investigation consists of the consideration of the tasks required of a structure and the evaluation of the responses of the structure in performing these tasks. Investigation may be performed in various ways, the principal ones being either the use of mathematical modeling or the construction of physical models.

For the designer, a major first step in any investigation is the visualization of the structure and the force actions to which it must respond. In this book, extensive use is made of graphic illustrations in order to encourage the reader to develop the habit of first clearly *seeing* what is happening, before proceeding with the essentially abstract procedures of mathematical investigation. To further emphasize the need for visualization, and the degree to which it can be carried out without any mathematical computations, the first chapter of the book presents the whole range of book topics in this manner. The reader is encouraged to read

Chapter 1 completely, and to study the many graphic illustrations. This initial study should help greatly in giving the reader a grasp for the many concepts to be presented later and for the whole body of the book's topic scope.

## STRUCTURAL MECHANICS

The branch of physics called *mechanics* concerns the actions of forces on physical bodies. Most of engineering design and investigation is based on applications of the science of mechanics. *Statics* is the branch of mechanics that deals with bodies held in a state of unchanging motion by the balanced nature (called *static equilibrium*) of the forces acting on them. *Dynamics* is the branch of mechanics that concerns bodies in motion or in a process of change of shape due to actions of forces. A static condition is essentially unchanging with regard to time; a dynamic condition implies a time-dependent action and response.

When external forces act on a body, two things happen. First, internal forces that resist the actions of the external forces are set up in the body. These internal forces produce *stresses* in the material of the body. Second, the external forces produce *deformations*, or changes in shape, of the body. *Strength of materials*, or mechanics of materials, is the study of the properties of material bodies that enable them to resist the actions of external forces, of the stresses within the bodies, and of the deformations of bodies that result from external forces.

Taken together, the topics of applied mechanics and strength of materials are often given the overall designation of *structural mechanics* or *structural analysis*. This is the fundamental basis for structural investigation, which is essentially an analytical process. On the other hand, *design* is a progressive refining process in which a structure is first generally visualized; then it is investigated for required force responses and its performance is evaluated; finally—possibly after several cycles of investigation and modification—an acceptable form is derived for the structure.

## UNITS OF MEASUREMENT

Early editions of this book have used U.S. units (feet, inches, pounds, etc.) for the basic presentation. In this edition, the basic work is developed with U.S. units with equivalent metric unit values in brackets [thus].

While the building industry in the United States is now in the process of changing over to the use of metric units, our decision for the presentation here is a pragmatic one. Most of the references used for this book are still developed primarily in U.S. units, and most readers educated in the United States will have acquired use of U.S. units as their “first language,” even if they now also use metric units.

Table 1 lists the standard units of measurement in the U.S. system with the abbreviations used in this work and a description of common usage in structural design work. In similar form, Table 2 gives the corresponding units in the metric system (or *Système International*, SI). Conversion factors to be used for shifting from one unit system to the other are given in Table 3. Direct use of the conversion factors will produce what is called a *hard conversion* of a reasonably precise form.

In the work in this book, many of the unit conversions presented are *soft conversions*, meaning one in which the converted value is rounded off to produce an approximate equivalent value of some slightly more relevant numerical significance to the unit system. Thus, a wood  $2 \times 4$  (actually  $1.5 \times 3.5$  inches in the U.S. system) is precisely  $38.1 \times 88.9$  mm in the metric system. However, the metric equivalent of a “2 by 4” is more likely to be made  $40 \times 90$  mm, close enough for most purposes in construction work.

For some of the work in this book, the units of measurement are not significant. What is required in such cases is simply to find a numerical answer. The visualization of the problem, the manipulation of the mathematical processes for the solution, and the quantification of the answer are not related to specific units—only to their relative values. In such situations, the use of dual units in the presentation is omitted in order to reduce the potential for confusion for the reader.

## ACCURACY OF COMPUTATIONS

Structures for buildings are seldom produced with a high degree of dimensional precision. Exact dimensions are difficult to achieve, even for the most diligent of workers and builders. Add this to considerations for the lack of precision in predicting loads for any structure, and the significance of highly precise structural computations becomes moot. This is not to be used as an argument to justify sloppy mathematical work, overly sloppy construction, or use of vague theories of investigation of

**TABLE 1 Units of Measurement: U.S. System**

Name of Unit	Abbreviation	Use in Building Design
<i>Length</i>		
Foot	ft	Large dimensions, building plans, beam spans
Inch	in.	Small dimensions, size of member cross sections
<i>Area</i>		
Square feet	ft <sup>2</sup>	Large areas
Square inches	in. <sup>2</sup>	Small areas, properties of cross sections
<i>Volume</i>		
Cubic yards	yd <sup>3</sup>	Large volumes, of soil or concrete (commonly called simply "yards")
Cubic feet	ft <sup>3</sup>	Quantities of materials
Cubic inches	in. <sup>3</sup>	Small volumes
<i>Force, Mass</i>		
Pound	lb	Specific weight, force, load
Kip	kip, k	1000 pounds
Ton	ton	2000 pounds
Pounds per foot	lb/ft, plf	Linear load (as on a beam)
Kips per foot	kips/ft, klf	Linear load (as on a beam)
Pounds per square foot	lb/ft <sup>2</sup> , psf	Distributed load on a surface, pressure
Kips per square foot	k/ft <sup>2</sup> , ksf	Distributed load on a surface, pressure
Pounds per cubic foot	lb/ft <sup>3</sup>	Relative density, unit weight
<i>Moment</i>		
Foot-pounds	ft-lb	Rotational or bending moment
Inch-pounds	in.-lb	Rotational or bending moment
Kip-feet	kip-ft	Rotational or bending moment
Kip-inches	kip-in.	Rotational or bending moment
<i>Stress</i>		
Pounds per square foot	lb/ft <sup>2</sup> , psf	Soil pressure
Pounds per square inch	lb/in. <sup>2</sup> , psi	Stresses in structures
Kips per square foot	kips/ft <sup>2</sup> , ksf	Soil pressure
Kips per square inch	kips/in. <sup>2</sup> , ksi	Stresses in structures
<i>Temperature</i>		
Degree Fahrenheit	°F	Temperature

**TABLE 2 Units of Measurement: SI System**

Name of Unit	Abbreviation	Use in Building Design
<i>Length</i>		
Meter	m	Large dimensions, building plans, beam spans
Millimeter	mm	Small dimensions, size of member cross sections
<i>Area</i>		
Square meters	m <sup>2</sup>	Large areas
Square millimeters	mm <sup>2</sup>	Small areas, properties of member cross sections
<i>Volume</i>		
Cubic meters	m <sup>3</sup>	Large volumes
Cubic millimeters	mm <sup>3</sup>	Small volumes
<i>Mass</i>		
Kilogram	kg	Mass of material (equivalent to weight in U.S. units)
Kilograms per cubic meter	kg/m <sup>3</sup>	Density (unit weight)
<i>Force, Load</i>		
Newton	N	Force or load on structure
Kilonewton	kN	1000 newtons
<i>Moment</i>		
Newton-meters	N-m	Rotational or bending moment
Kilonewton-meters	kN-m	Rotational or bending moment
<i>Stress</i>		
Pascal	Pa	Stress or pressure (1 pascal = 1 N/m <sup>2</sup> )
Kilopascal	kPa	1000 pascals
Megapascal	MPa	1,000,000 pascals
Gigapascal	GPa	1,000,000,000 pascals
<i>Temperature</i>		
Degree Celsius	°C	Temperature

**TABLE 3 Factors for Conversion of Units**

To convert from U.S. Units to SI Units, Multiply by:	U.S. Unit	SI Unit	To convert from SI Units to U.S. Units, Multiply by:
25.4	in.	mm	0.03937
0.3048	ft	m	3.281
645.2	in. <sup>2</sup>	mm <sup>2</sup>	$1.550 \times 10^{-3}$
$16.39 \times 10^3$	in. <sup>3</sup>	mm <sup>3</sup>	$61.02 \times 10^{-6}$
$416.2 \times 10^3$	in. <sup>4</sup>	mm <sup>4</sup>	$2.403 \times 10^{-6}$
0.09290	ft <sup>2</sup>	m <sup>2</sup>	10.76
0.02832	ft <sup>3</sup>	m <sup>3</sup>	35.31
0.4536	lb (mass)	kg	2.205
4.448	lb (force)	N	0.2248
4.448	kip (force)	kN	0.2248
1.356	ft-lb (moment)	N-m	0.7376
1.356	kip-ft (moment)	kN-m	0.7376
16.0185	lb/ft <sup>3</sup> (density)	kg/m <sup>3</sup>	0.06243
14.59	lb/ft (load)	N/m	0.06853
14.59	kip/ft (load)	kN/m	0.06853
6.895	psi (stress)	kPa	0.1450
6.895	ksi (stress)	MPa	0.1450
0.04788	psf (load or pressure)	kPa	20.93
47.88	ksf (load or pressure)	kPa	0.02093
$0.566 \times (^{\circ}\text{F} - 32)$	$^{\circ}\text{F}$	$^{\circ}\text{C}$	$(1.8 \times ^{\circ}\text{C}) + 32$

Source: Adapted from data in the *Manual of Steel Construction*, 8<sup>th</sup> edition, with permission of the publishers, American Institute of Steel Construction. This table is a sample from an extensive set of tables in the reference document.

behaviors. Nevertheless, it makes a case for not being highly concerned with any numbers beyond about the second digit.

While most professional design work these days is likely to be done with computer support, most of the work illustrated here is quite simple and was actually performed with a hand calculator (the eight-digit, scientific type is adequate). Rounding off of these primitive computations is done with no apologies.

With the use of the computer, accuracy of computational work is a somewhat different matter. Still, it is the designer (a person) who makes judgements based on the computations, and who knows how good the

input to the computer was, and what the real significance of the degree of accuracy of an answer is.

## SYMBOLS

The following shorthand symbols are frequently used.

Symbol	Reading
$>$	is greater than
$<$	is less than
$\geq$	is equal to or greater than
$\leq$	is equal to or less than
6'	6 feet
6"	6 inches
$\Sigma$	the sum of
$\Delta L$	change in $L$

## NOMENCLATURE

Notation used in this book complies generally with that used in the building design field. A general attempt has been made to conform to usage in the 1997 edition of the *Uniform Building Code*, UBC for short (Ref. 1). The following list includes all of the notation used in this book that is general and is related to the topic of the book. Specialized notation is used by various groups, especially as related to individual materials: wood, steel, masonry, concrete, and so on. The reader is referred to basic references for notation in special fields. Some of this notation is explained in later parts of this book.

Building codes, including the UBC, use special notation that is usually carefully defined by the code, and the reader is referred to the source for interpretation of these definitions. When used in demonstrations of computations, such notation is explained in the text of this book.

$A_g$  = gross (total) area of a section, defined by the outer dimensions

$A_n$  = net area

$C$  = compressive force

$E$  = modulus of elasticity (general)

$F$  = (1) force; (2) a specified limit for stress

$I$  = moment of inertia

$L$  = length (usually of a span)

$M$  = bending moment

$P$  = concentrated load

$S$  = section modulus

$T$  = tension force

$W$  = (1) total gravity load; (2) weight, or dead load of an object;  
(3) total wind load force; (4) total of a uniformly distributed load or pressure due to gravity

$a$  = unit area

$e$  = (1) total dimensional change of length of an object, caused by stress or thermal change; (2) eccentricity of a nonaxial load, from point of application of the load to the centroid of the section

$f$  = computed direct stress

$h$  = effective height (usually meaning unbraced height) of a wall or column

$l$  = length, usually of a span

$s$  = spacing, center to center

$v$  = computed shear stress



# 1

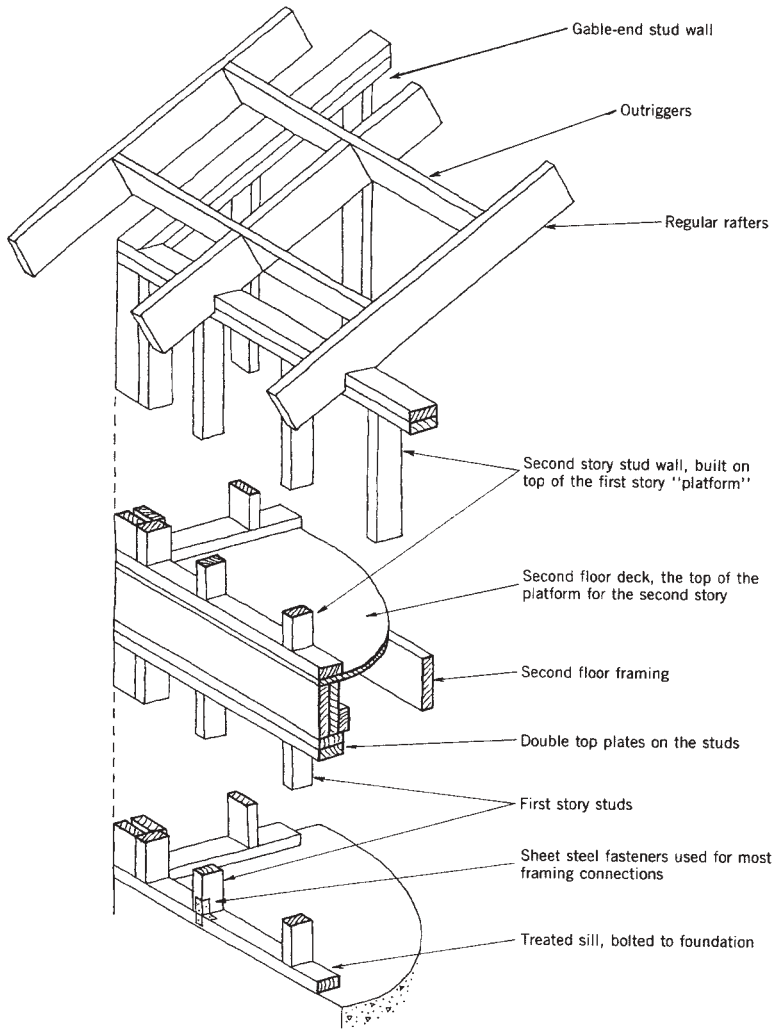
---

## STRUCTURES: PURPOSE AND FUNCTION

---

This book deals with the behavior of structures; in particular, with structures for buildings. The behavior referred to is that which occurs when the structures respond to various force actions produced by natural and usage-generated effects. Investigation of structural behaviors has the direct purpose of supporting an informed design of the structures and an assurance as to the safety of the construction with regard to the building occupants.

Structural behaviors may be simple or complex. This quality may derive from the nature of the loads on the structure—from simple gravity to the dynamic effects of earthquakes. It may also derive from the nature of the structure itself. For example, the simple structure shown in Figure 1.1 has basic elements that yield to quite elementary investigation for behavior. This book provides a starting point for the most elementary investigations of structures. It can be the beginning of a long course of study for persons interested in the investigation and design of highly complex structures.



**Figure 1.1** An All-American classic structure: the light wood frame, achieved almost entirely with "2 x" dimension lumber. Wall studs serve as columns to support horizontal members in the time-honored post and beam system with its roots in antiquity. While systems of much greater sophistication have been developed, this is still the single most widely used structure in the United States today.

Consider the problems of the structure that derive from its performance of various load resisting functions. The basic issues to be dealt with are:

The load sources and their effects.

What the structure accomplishes in terms of its performance as a supporting, spanning, or bracing element.

What happens to the structure internally as it performs its various tasks.

What is involved in determining the necessary structural elements and systems for specific structural tasks.

We begin this study with a consideration of the loads that affect building structures.

## 1.1 LOADS

Used in its general sense, the term *load* refers to any effect that results in a need for some resistive response on the part of the structure. There are many different sources for loads, and many ways in which they can be classified. The principal kinds and sources of loads on building structures are the following.

### Gravity

*Source:* The weight of the structure and of other parts of the construction; the weight of building occupants and contents; the weight of snow, ice, or water on the roof.

*Computation:* By determination of the volume, density, and type of dispersion of items.

*Application:* Vertically downward and constant in magnitude.

### Wind

*Source:* Moving air.

*Computation:* From anticipated wind velocities established by local weather history.

*Application:* As pressure perpendicular to exterior surfaces or as shearing drag parallel to exterior surfaces. Primarily considered as a horizontal force from any compass point, but also with a vertical component on sloping surfaces and vertical uplift on flat roofs.

### **Earthquake (Seismic Shock)**

*Source:* Vibration of the ground as a result of a subterranean shock.

*Computation:* By prediction of the probability of occurrence based on local history of seismic activity.

*Application:* Back-and-forth, up-and-down movement of the ground on which a building sits, resulting in forces induced by the inertial effect of the building's weight.

### **Blast**

*Source:* Explosion of bomb, projectile, or volatile materials.

*Computation:* As pressure, depending on the magnitude of the explosion and its proximity to the structure.

*Application:* Slamming force on surfaces surrounding the explosion.

### **Hydraulic Pressure**

*Source:* Principally from groundwater levels above the bottom of the basement floor.

*Computation:* As fluid pressure proportional to the depth below the water top surface.

*Application:* As horizontal pressure on basement walls and upward pressure on basement floors.

### **Thermal Change**

*Source:* Temperature changes in the building materials caused by fluctuations of outdoor temperature.

*Computation:* From weather histories, coefficient of expansion of materials, and amount of exposure of the individual parts of the construction.

*Application:* Forces exerted when parts are restrained from expanding or contracting; distortions of building if connected parts differ in temperature or have significantly different coefficients of expansion.

## **Shrinkage**

Natural volume reduction occurs in concrete, in the mortar joints of masonry, in green wood, and in wet clay soils. These can induce forces in a manner similar to thermal change.

## **Vibration**

In addition to earthquake effects, vibration of the structure may be caused by heavy machinery, moving vehicles, or high intensity sounds. These may not be a critical force issue, but can be a major concern for sensation by occupants.

## **Internal Actions**

Forces may be generated within a structure by settlement of supports, slippage or loosening of connections, or by shape changes due to sag, warping, shrinkage, and so on.

## **Handling**

Forces may be exerted on elements of the structure during production, transportation, erection, storage, and so on. These may not be evident when considering only the normal use of the building, but must be considered for the life of the structure.

## **1.2 SPECIAL CONSIDERATIONS FOR LOADS**

In addition to identifying load sources, it is necessary to classify loads in various ways. The following are some such classifications.

## Live and Dead Loads

For design, a distinction is made between so-called *live* and *dead* loads. A dead load is essentially a permanent load, such as the weight of the structure itself and the weight of other permanent elements of the building construction supported by the structure. A live load is technically anything that is not permanently applied as a force on the structure. However, the specific term “live load” is typically used in building codes to refer to the assumed design loads in the form of dispersed load on the roof and floor surfaces that derive from the building location and its usage.

## Static versus Dynamic Forces

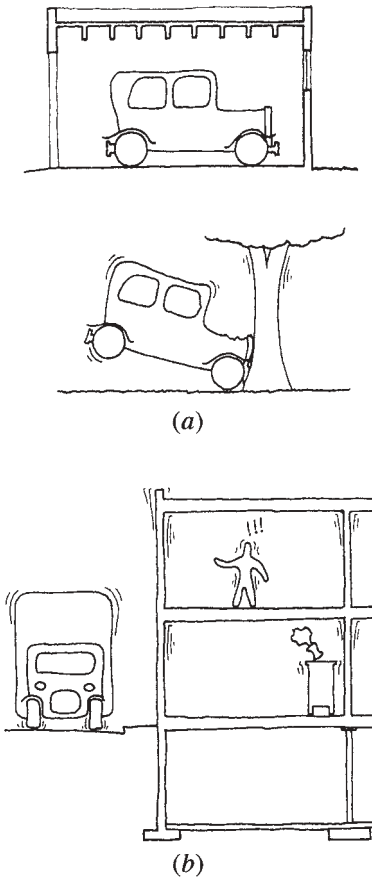
This distinction has to do essentially with the time-dependent character of the force. Thus, the weight of the structure produces a static effect, unless the structure is suddenly moved or stopped from moving, at which time a dynamic effect occurs due to the inertia or momentum of the mass of the structure (see Figure 1.2a). The more sudden the stop or start, the greater the dynamic effect.

Other dynamic effects are caused by ocean waves, earthquakes, blasts, sonic booms, vibration of heavy machinery, and the bouncing effect of people walking or of moving vehicles. Dynamic effects are different in nature from static effects. A light steel-framed building, for instance, may be very strong in resisting static forces, but a dynamic force may cause large distortions or vibrations, resulting in cracking of plaster, breaking of window glass, loosening of structural connections, and so on. A heavy masonry structure, although possibly not as strong as the steel frame for static load, has considerable stiffness and dead weight, and may thus absorb the energy of the dynamic force without perceptible movement.

In the example just cited, the effect of the force on the function of the structure was described. This may be distinct from any potential damaging effect on the structure. The steel frame is flexible and may respond with a degree of movement that is objectionable. However, from a structural point of view it is probably more resistive to dynamic force than the masonry structure. Steel is strong in tension and tends to dissipate some of the dynamic force through movement, similar to a boxer rolling with

a punch. Masonry, in contrast, is brittle and stiff and absorbs the energy almost entirely in the form of shock to the material.

In evaluating dynamic force effects and the response of structures to them, both the effect on the structure and the effect on its performance must be considered (see Figure 1.2*b*). Success for the structure must be measured in both ways.

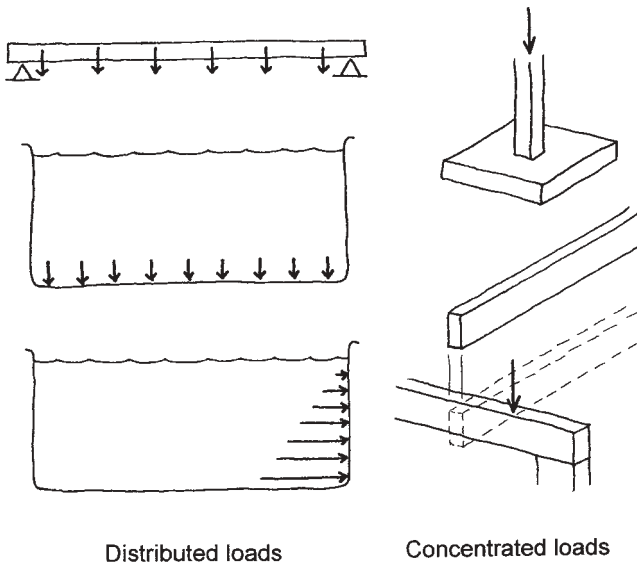


**Figure 1.2** (a) Static versus dynamic force effects. (b) Effects of vibration on occupant's sense of the building's solidity.

## Load Dispersion

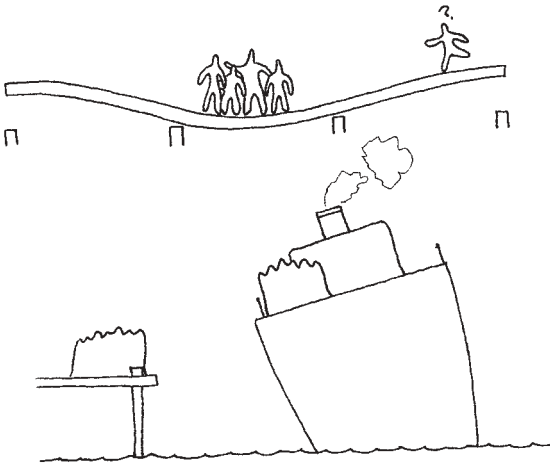
Forces are also distinguished by the manner of their dispersion. Gas under pressure in a container exerts a pressure that is uniformly dispersed in all directions at all points. The dead load of roofing, the weight of snow on a roof, and the weight of water on the bottom of a tank are all loads that are uniformly distributed on a surface. The weight of a beam or a suspended cable is a load that is uniformly distributed in a linear manner. On the other hand, the foot of a column or the end of a beam represent loads that are concentrated at a relatively small location (see Figure 1.3).

Randomly dispersed live loads may result in unbalanced conditions or in reversals of internal forces in the structure (see Figure 1.4). Since live loads are generally variable in occurrence, it may be necessary to consider various arrangements and combinations of them in order to determine the worst effects on the structure.



**Figure 1.3** Dispersion of loads.





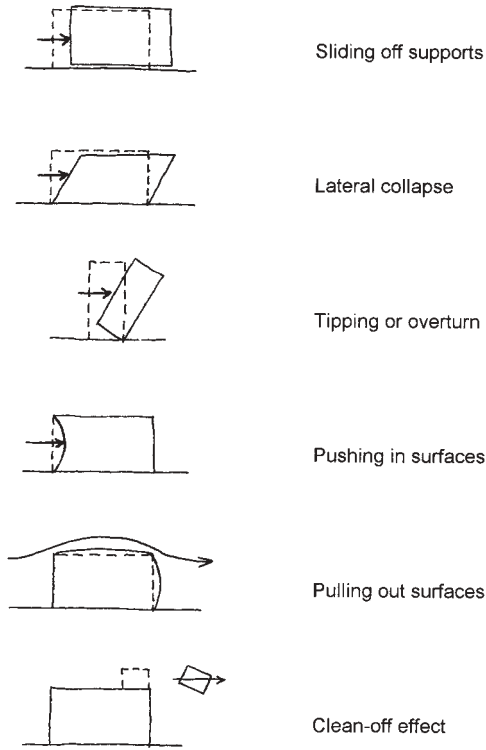
**Figure 1.4** Unbalanced loads.

## Wind

Wind is moving air, and thus, it has an impact on any static object in its path, just as water flowing in a stream has an impact on a large rock or a bridge pier. The fluid flow of the air also produces various other effects, such as those shown in Figure 1.5. The form, surface texture, and size of the building, as well as the sheltering effect of ground forms, large trees, or other nearby buildings, may modify the effects of wind.

While gravity is a constant magnitude, single direction force, wind is variable in both magnitude and direction. Although usually directed parallel to the ground surface, wind can cause aerodynamic effects in other orientations, resulting in both inward and outward pressures on individual surfaces of a building. Violent winds are usually accompanied by gusts, which are brief surges in the wind velocity. Gusts produce impacts on surfaces and may result in jerking or rocking of small buildings.

Wind magnitude is measured in terms of velocity (wind speed). The effect on buildings is translated into force in terms of pressures on the exterior building surfaces, measured in pounds per square foot (psf). From physics, this pressure varies with the square of the velocity. For the case



**Figure 1.5** Wind loads on buildings.

of small to medium size buildings with flat sides, sitting on the ground, an approximation of the total force from these pressures is visualized in the form of a single pressure on the building windward side of

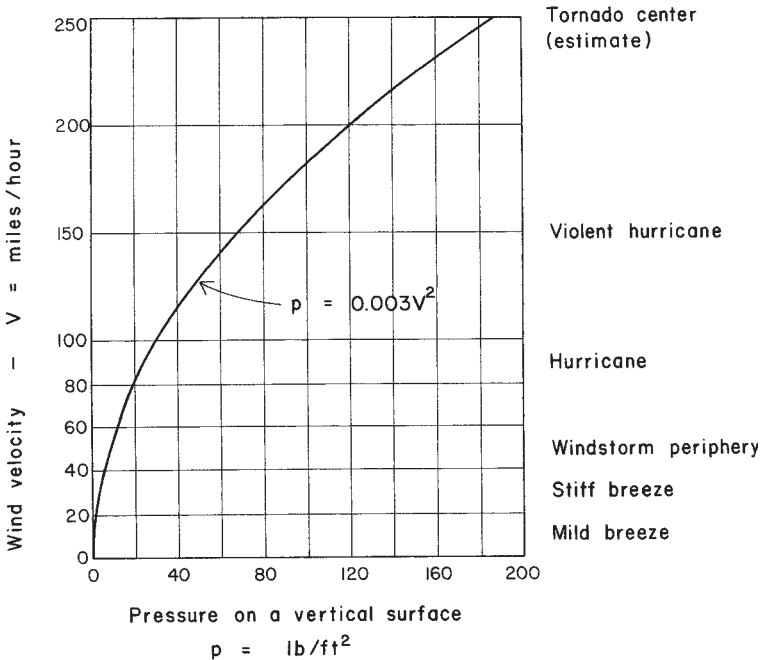
$$p = 0.003V^2$$

in which

$p$  = pressure on the vertical surface, in units of psf

$V$  = wind velocity in units of miles per hour (mph)

A plot of this equation is shown in Figure 1.6. Local weather histories are used to establish the maximum anticipated wind speeds for a given loca-



**Figure 1.6** Relation of wind velocity (speed) to surface pressure on buildings. Reproduced from *Simplified Building Design for Wind and Earthquake Forces*, 3rd edition, by J. Ambrose and D. Vergun, 1995, with permission of the publisher, John Wiley & Sons, New York.

tion, which are then used to establish the code-required design pressures used for design of structures in that region.

### Earthquakes

Earthquakes can have various disastrous effects on buildings. The primary direct effect is the shaking of the ground produced by the shock waves that emanate from the center of the earthquake. The rapidity, duration, and magnitude of this shaking depend on the intensity of the earthquake, on the geological nature of the earth between the earthquake and the building site, and on the dynamic response character of the site itself.

The shaking effect of an earthquake may be a source of serious distress to the building or its occupants. The force effect on the structure is directly related to the weight of the building and is modified by various dynamic properties of the structure. As the base of a building is suddenly moved, the upper part of the building at first resists moving. This results in a distortion of the structure, with the base laterally displaced while the upper part momentarily remains stationary. Then, as the upper part finally moves, the base suddenly reverses direction, which produces a force due to the momentum of the upper part. This action can produce sliding, toppling, or total collapse of the building. Repeated several dozen times during an earthquake, it can also produce progressive failure of the structure and a fun ride for the building occupants.

If a structure is large, tall, and flexible, its relatively slow response can set up whiplashlike effects, as shown in Figure 1.7. If a structure is small, short, and stiff, its motion will be essentially the same as that of the ground. In addition to the direct shaking action, there are other potential destructive effects from earthquakes, including:

- Settling, cracking, or lateral shifting of the ground surface.

- Landslides, avalanches, rock falls, or glacial faults.

- Tidal waves that can travel long distances and cause damage to coastal areas.

- Surging of water in lakes, reservoirs, and large water tanks.

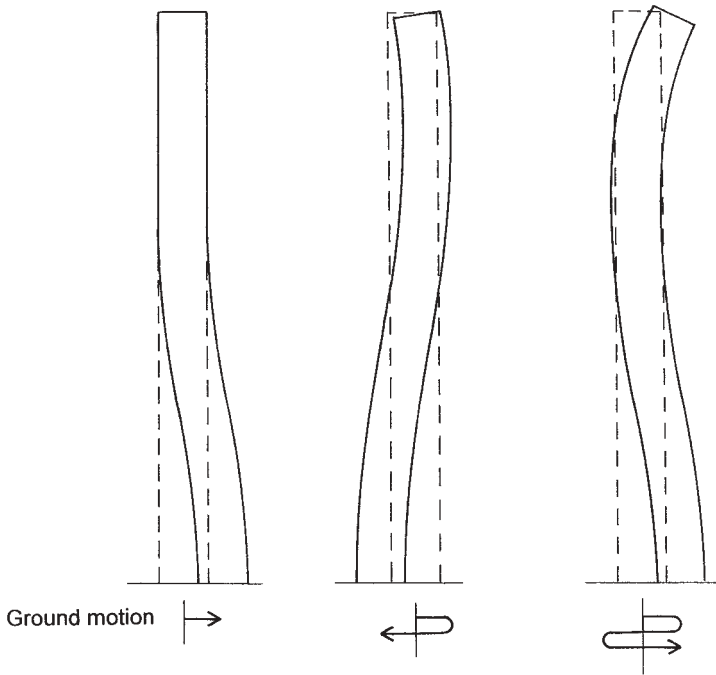
- Explosions and fires resulting from broken gas or oil pipelines.

- Major interruption of community services for power, water supply, or communication, due to damage to buried utilities, to transmission towers, to electrical transformers, and so on.

The potential for disaster is enormous, but the reality is tempered by the infrequent occurrence of major earthquakes, their highly localized nature, and our steady development of more resistive structures. Sadly but beneficially, each major earthquake works to reduce the inventory of vulnerable structures for the next earthquake.

## **Load Combinations**

A difficult judgement for the designer is that of the likelihood of simultaneous occurrence of forces from various sources. Potential combina-



**Figure 1.7** Earthquake effects on tall structures. Reproduced from *Simplified Building Design for Wind and Earthquake Forces*, 3rd edition, by J. Ambrose and D. Vergun, 1995, with permission of the publisher, John Wiley & Sons, New York.

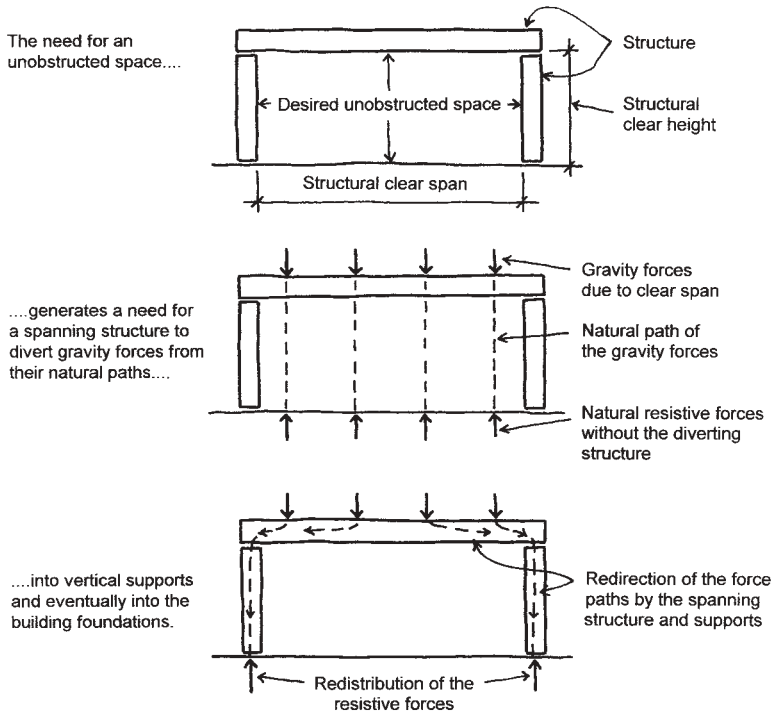
tions must be studied carefully to determine those that cause critical situations and that have some reasonable possibility of actual simultaneous occurrence. For example, it is not reasonable to design for the simultaneous occurrence of a major wind storm and a major earthquake. Nor is it possible for the wind to blow simultaneously from more than one direction.

### 1.3 GENERATION OF STRUCTURES

The making of buildings involves a number of situations that generate a need for structures.

### Need for Unobstructed Interior Space

Housing of activities creates the need for producing unobstructed interior spaces that are free of vertical elements of the building structure. These spaces may be very small (closets and bathrooms) or very large (sports arenas). Generating open, enclosed, interior space involves the basic structural task of spanning, as shown in Figure 1.8. The magnitude of the spanning task is determined by the length of the span and the loads on the spanning structure. As the span increases, the required structural effort increases rapidly, and feasible options for the spanning structure narrow to a few choices.



**Figure 1.8** The structural task of generating unobstructed interior space.

## Architectural Elements

Most buildings consist of combinations of three basic elements: walls, floors, and roofs. These elements are arranged to create both space division and clear-spanned, unobstructed, interior spaces.

**Walls.** Walls are usually vertical and potentially lend themselves to the task of supporting roofs and floors. Even when they do not serve as supports, they often incorporate the columns that do serve this purpose. Thus, the design development of spanning roof and floor systems begins with the planning of the wall systems over which they span. Walls may be classified on the basis of their architectural functions and their structural tasks, and this classification affects judgements about their form in terms of thickness and of stiffness in their own planes, as shown in Figure 1.9.

**Floors.** Floor structures are often dual in function, providing for a floor surface above and a ceiling surface below. The floor function usually dictates the need for a flat, horizontal geometry; thus, most floor structures are of the flat-spanning category (not arches, catenary cables, etc.). Most floor structures are relatively short in span, owing to the high loadings and the inefficiency of the flat-spanning structure.

**Roofs.** Roofs have two primary functions: to act as skin elements for the building and to drain away water from rain and melting snow. Whereas floors must usually be flat, roofs must usually not be, as some sloped form is required for water drainage. Thus, even so-called flat roofs have some minimum slope for draining the roof surface to designated collector elements (gutters, downspouts, gargoyles, etc.). Floors also need some rigidity for a solid feeling when walked on. Because of their freedom from requirements for horizontal flatness and solidity, roofs have a great range of possibilities for geometry and nonflat structure; thus, most really long spans and exotic structural geometries are achieved with roof structures.

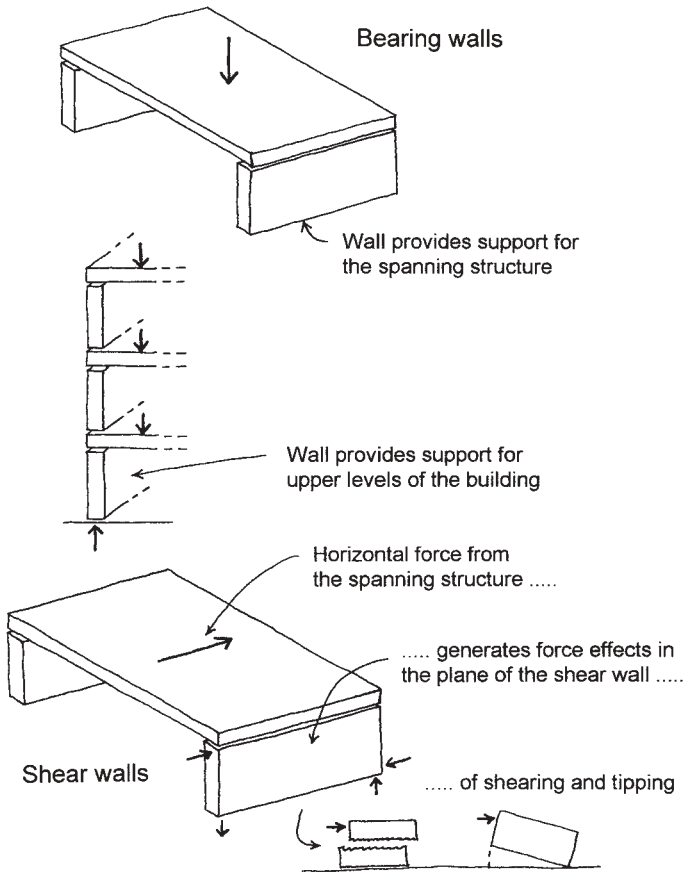
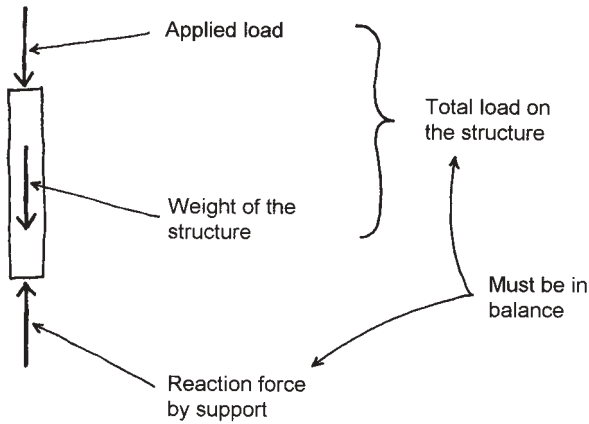


Figure 1.9 Structural functions of walls.

## 1.4 REACTIONS

Successful functioning of the structure in resisting loads involves two fundamental considerations. First, the structure must have sufficient internal strength and stiffness to redirect the loads to its supports without developing undue stress on its materials or an undesirable amount of deformation (sag, etc.). Second, the supports for the structure must keep the





**Figure 1.10** Applied and reactive forces on a column.

structure from collapsing. The required forces developed by the supports are called reactions.

Figure 1.10 shows a column supporting a load that generates a linear compressive effect. The reaction generated by the column's support must be equal in magnitude and opposite in sense (up versus down) to the column load. The balancing of the active force (column load) and reactive force (support reaction) produces the necessary state of static equilibrium; thus, no movement occurs.

Figure 1.11 shows the reaction forces required for various structures. The simple spanning beam requires only two vertical forces for support. However, the gable frame, arch, and draped cable also require horizontal restraint at their supports. Structural behavior of the elements is different in each of the four types of spanning structures shown in Figure 1.11, as is the required effort by the supports. These differences are due to the differing forms of the structures, even though all four basically perform the same spanning task.

There is another type of reaction effort that can be visualized by considering the situation of the cantilever beam, as shown in Figure 1.12. Since there is no support at the free end of the beam, the support at the other end must develop a resistance to rotation of the beam end, as well as resistance to the vertical load. The rotational effect is called moment, and it has a unit that is different from that of direct force. Force is measured

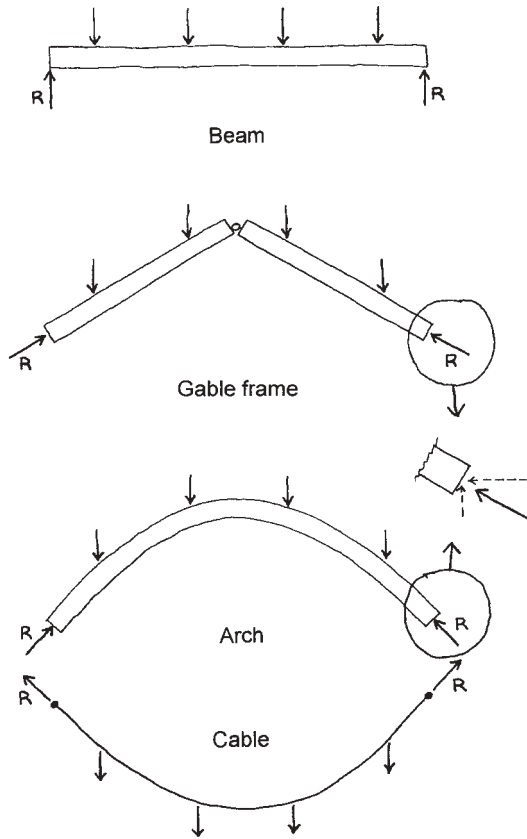


Figure 1.11 Reactions  $R$  for various spanning structures.

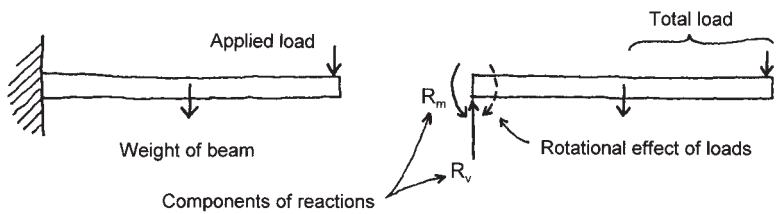


Figure 1.12 Reactions for a cantilever beam.

in weight units: pounds, tons, and so on. Moment is a product of force and distance, resulting in a compound unit of pound-feet, or some other combination of force and length units. The total support reaction for the cantilever therefore consists of a combination of the vertical force ( $R_v$ ) and the resisting moment ( $R_m$ ).

For the rigid frame shown in Figure 1.13, there are three possible components of the reactions. If vertical force alone is resisted at the supports, the bottoms of the columns will move outward and rotate, as

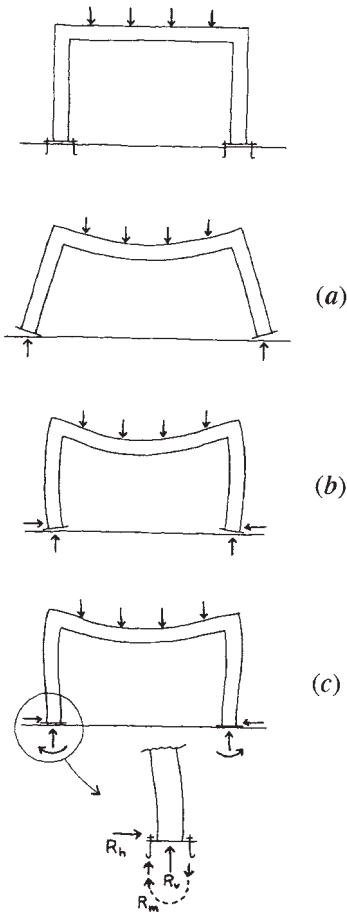


Figure 1.13 Reactions for a rigid frame.

shown in Figure 1.13*a*. If horizontal resistance is developed, as shown for the gable, arch, and cable in Figure 1.11, the column bottoms can be pushed back to their unloaded positions, but they will still rotate, as shown in Figure 1.13*b*. Finally, if a moment resistance is developed by the supports, the column bottoms can be held completely in their original positions, as shown in Figure 1.13*c*.

The combination of loads and support reactions constitutes the total external effort on a structure. This system is in some ways independent of the structure; that is, the external forces must be in equilibrium, regardless of the materials, strength, and so on, of the structure. For example, the task for a beam can be totally defined in terms of effort without reference to what the beam actually consists of.

With its tasks defined, however, it becomes necessary to consider the response developed by the structure. This means moving on to consider what happens inside the structure in terms of internal force effects.

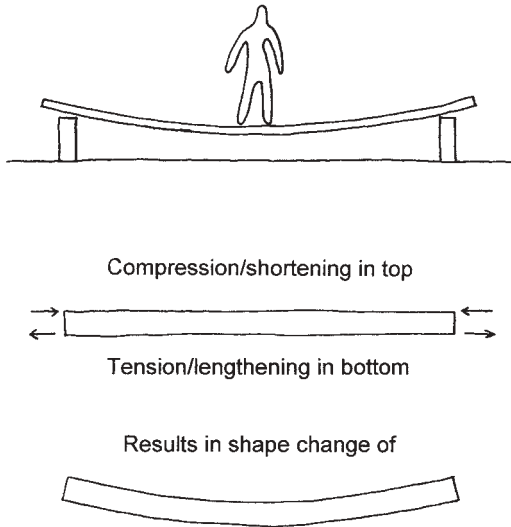
## 1.5 INTERNAL FORCES

In response to the external effects of loads and reactions, internal forces are developed within a structure as the material of the structure strives to resist the deformations caused by the external effects. These internal force effects are generated by stresses in the material of the structure. The stresses are actually incremental forces within the material, and they result in incremental deformations, called strains.

### Cause and Effect: External versus Internal Force

When subjected to external forces, a structure twists, sags, stretches, shortens, and so on. To be more technical, it stresses and strains, thus assuming some new shape as the incremental strains accumulate into overall dimensional changes. While stresses are not visually apparent, their accompanying strains are; thus, it is possible to infer a stress condition from observation of structural deformations.

As shown in Figure 1.14, a person standing on a wooden plank that spans between two supports will cause the plank to sag downward and assume a curved profile. The sag may be visualized as the manifestation of a strain phenomenon accompanied by a stress phenomenon. In this ex-



**Figure 1.14** Internal bending.

ample, the principal cause of the structure's deformation is bending resistance, called internal resistive bending moment.

The stresses associated with the internal force action of bending moment are horizontally directed compression in the upper portion of the plank and horizontally directed tension in the lower portion. Anyone could have predicted that the plank would sag when the person stepped on it. But we can also predict the deformation as an accumulation of strains, resulting in the shortening of the upper portion and the lengthening of the lower portion of the plank. Thus, the stress condition can be inferred from observed deformation, but likewise the deformation can be predicted from known stress conditions.

For the relatively thin wooden plank, the bending action and strain effects are quite apparent. If the plank is replaced by a thick wooden beam, the sag will not be visually apparent with a light load and a short span. However, the internal bending still occurs and the sag—however slight—does exist. For the investigation of structural behaviors, visualization of internal forces is aided by considering an exaggerated deformation of the structure, assuming it to be much more flexible than it really is.

## 1.6 FUNCTIONAL REQUIREMENTS OF STRUCTURES

Any structure subjected to loads must have certain characteristics in order to function. For purposes of structural resistance, it must be inherently stable, must have adequate strength for an acceptable margin of safety, and must have a reasonable stiffness for resistance to deformation. These three basic characteristics—stability, strength, and stiffness—are the principal functional requirements of structures.

### Stability

Stability has both simple and complex connotations. In the case of the wooden plank, it is essential that there be two supports and that the person stand between the supports. As shown in Figure 1.15, if the plank extends over one support, and a person stands on the extended end, disaster will certainly occur unless a counterweight is placed on the plank or the plank is anchored to the opposite support. In this case, either the counterweight or the anchorage is necessary for the stability of the structure—unrelated to the strength or stiffness of the plank.

A slightly different problem of stability is illustrated by another example. Suppose you have a sore foot and want to use a walking stick to assist your travel. You are offered a  $\frac{3}{4}$ -in. round wooden stick and a  $\frac{1}{4}$ -in. round steel rod, each 3 ft long. After handling both, you would probably choose the wooden stick, since the steel rod would buckle under your weight. This buckling action can be visualized, demonstrated, and measured. The essential property of a structure that determines its buckling potential is its slenderness.

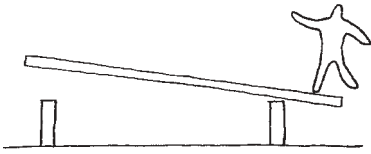
In engineering analysis, the geometric property of slenderness used to establish the likelihood of buckling is the slenderness ratio, also called the relative slenderness, expressed as

$$L/r$$

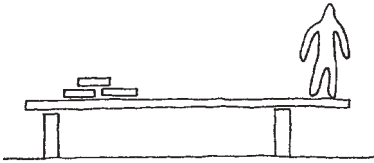
in which

$L$  = length of the compression member over which there is no lateral bracing to prevent buckling

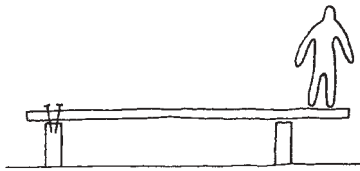
$r$  = a geometric property of the member cross section called the radius of gyration



Unstable



Stabilized with counterweight



Stabilized with anchorage

Figure 1.15 Developing stability.

The geometric property  $r$  can be expressed as

$$r = \left( \frac{I}{A} \right)^{1/2}$$

In this formula,

$A$  = the member cross-sectional area

$I$  = a property called the second moment of the area or the moment of inertia

While  $A$  is a direct measure of the amount of material in the member,  $I$  is a measure of the member's stiffness in resisting bending—which is what buckling becomes once it is initiated.

In the example of the walking stick, the  $\frac{3}{4}$ -in. diameter wooden stick has an  $L/r$  of 192, while the  $\frac{1}{4}$ -in. steel rod has an  $L/r$  of 576. If we take the steel and flatten it out and roll it up to produce a cylinder with a  $\frac{3}{4}$  in. diameter, the area remains the same, but the  $I$  value is significantly increased. Furthermore, the  $r$  value is thus also increased, so that the  $L/r$  now becomes 136. As long as the cylinder wall is not made too thin, the pipe-shaped stick represents a major improvement in buckling resistance. Figure 1.16 shows the three cross sections and the corresponding  $L/r$  values.

Bending and buckling stiffness are also affected by the stiffness of the material. Thus, a  $\frac{1}{4}$  in. rod of wood would be even less stiff than the one of steel, since wood is considerably less stiff than steel. For a single, very slender, compression member, the compression force required to produce buckling is expressed by the Euler formula, shown in the plot of compression failure versus length in Figure 1.17. As the member is shortened, buckling becomes less critical, and the limiting effect becomes simple compressive crushing of the material. At very short lengths, therefore, the compression limit is determined by the stress resistance of the

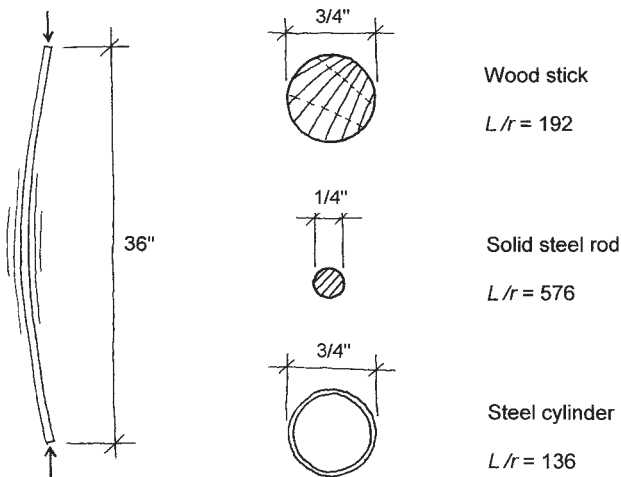
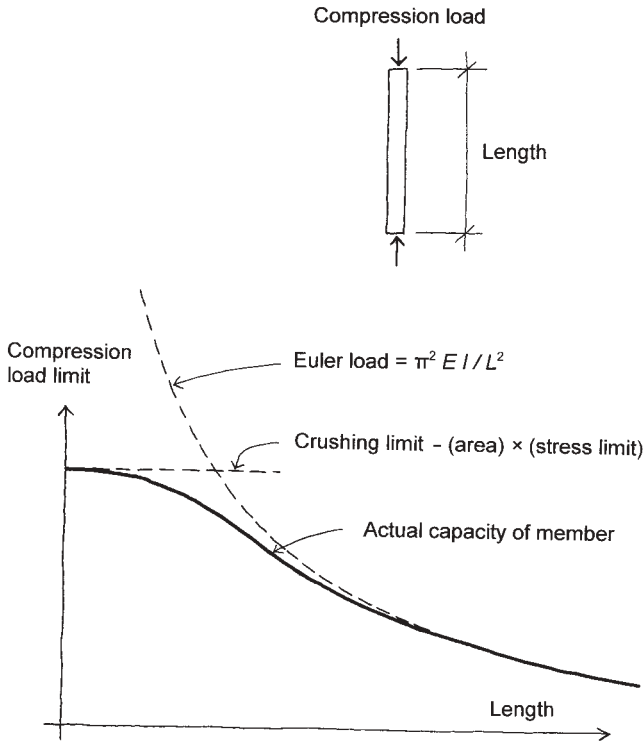


Figure 1.16 Relative  $L/r$  values.

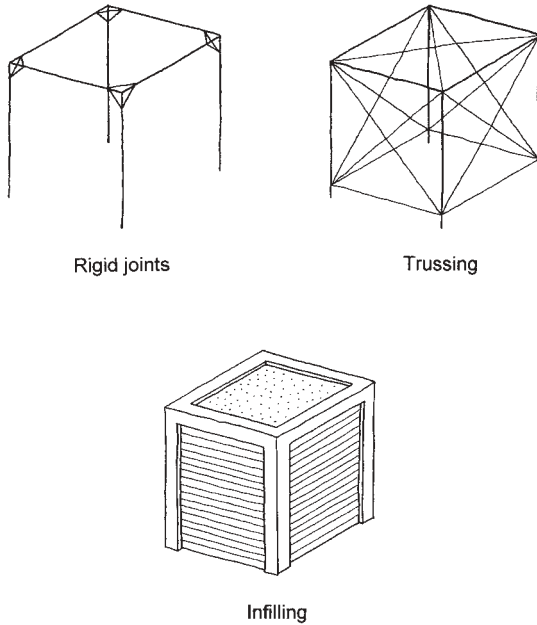




**Figure 1.17** Compression load limit versus member slenderness.  $E$  is a factor that indicates the stiffness of the material.

material. At the other end of the graph, the curve becomes that of the Euler formula, in which the index of the member resistance is stiffness—of both the member cross section ( $I$ ) and the material ( $E$ , which is the stiffness modulus of the material). Between the limits, the curve slowly changes from one form to the other, and the buckling phenomenon contains some aspect of both types of failure.

Stability can be a problem for a single structural member, such as a single column, or it can be a problem for a whole structural assemblage. The eight-element framework shown in Figure 1.18 may be stable in resisting vertical gravity loads, but it must be braced in some manner against any horizontal forces, such as those caused by wind or earthquakes. The illustrations in Figure 1.18 show the three principal means



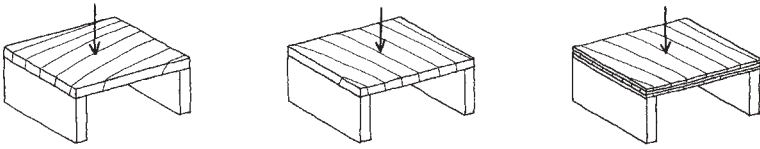
**Figure 1.18** Means of stabilizing a frame structure.

for achieving this stability: by using rigid joints between members, by using truss bracing in the wall planes, or by using rigid panels in the wall planes, called infilling.

## Strength

Strength is probably the most obvious requirement for a structure. Even though it is stable, the plank in Figure 1.14 is not strong enough to hold the weight of ten people. This has to do partly with the material—if the plank were made of steel, it might do the job. It also has to do with the form and orientation of the plank cross section—if the wood plank were turned on its edge, like a floor joist, it would probably also support ten people.

Material strength often depends on the type of stress that the material must sustain. Steel is adaptable and capable of major resistance to tension, compression, shearing, twisting, and bending with equal dexterity. Wood, however, has different strengths depending on the direction of the stress with reference to the wood grain. As shown in Figure 1.19, the develop-



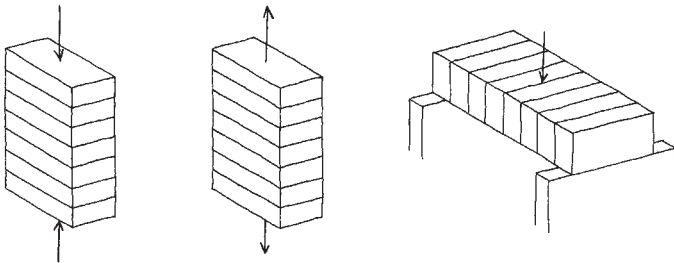
**Figure 1.19** Effect of orientation to load.

ment of major stresses perpendicular to the wood grain direction can cause the wood to fail easily. Reforming the wood, either by glue lamination or by pulverising the wood and using the wood fiber to produce compressed fiber panels, is a way of overcoming the grain limitation.

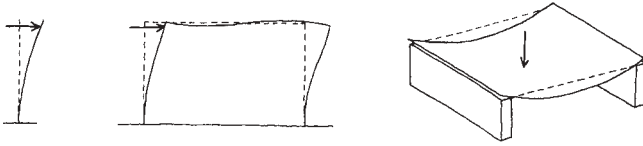
Stone, concrete, and fired clay are examples of materials that have varying strengths for different stresses. All are relatively strong in resisting compression, but are much less strong in resisting tension or shear. This requires caution in their use in structures to avoid these stresses or to compensate for them—such as by using steel reinforcement in concrete structures.

Attention must be given both to the form and nature of elements and to their uses. A cable assembled from thin steel wires has little resistance to compression or bending or to anything but the single task for which it is formed—resisting tension. This is so despite the fact that the steel, as a material, has other stress potentials.

A stack of bricks with no bonding in the joints has the capability of supporting a compressive load applied directly downward on the top of the stack. Picking the unbonded stack up by lifting the top brick or turning the stack sideways to create a spanning structure, as shown in Figure 1.20, is obviously not possible. Thus, joint formation of elements in an assembled structure is also a concern for strength.



**Figure 1.20** Effect of orientation to load.



**Figure 1.21** Deformation of structures under load.

## Stiffness

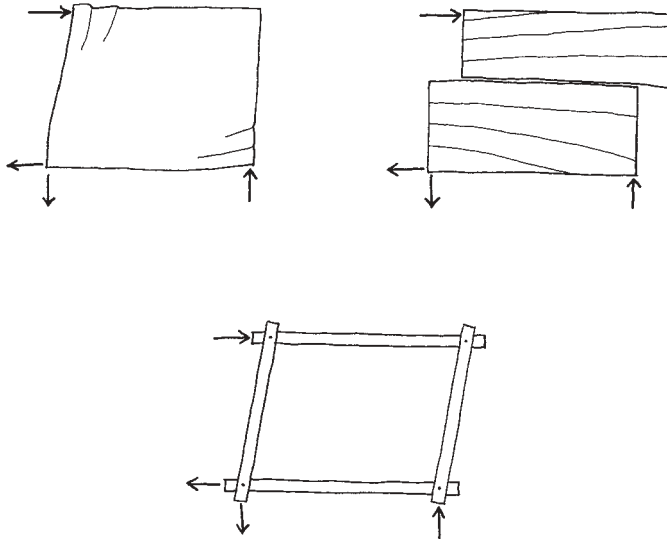
All structures change shape and move when subjected to forces (see Figure 1.21). The relative magnitude of these changes determines a quality of the structure called rigidity or stiffness. The degree of stiffness depends on the material of the structure, on the configuration of its parts, and—for assemblages—on the arrangement of the assembled members. It may also depend on the connections between parts and on the type of restraint offered by supports. The presence or absence of bracing may also be a factor.

Although stiffness is usually not as critical to the safety of a structure as strength and stability, it is frequently important for use of the structure. If a slammed door rocks the whole building, or if floors bounce when walked on, the users of the building will probably not be satisfied with the structure.

## Equilibrium of Structures

Most structures act as transfer elements, receiving certain forces and transferring them to other points. This transfer capability is dependent on the internal strength and stability of the structure. As shown in Figure 1.22, a thin sheet of aluminum may be easily buckled, a block of wood may be easily split along its grain, and a rectangular framework with loose, single-pin joints may be easily collapsed sideways. All of these structures fail because of an inability to maintain internal equilibrium through lack of strength, or because of the lack of some inherent stability, or for both reasons.

The complete static equilibrium of a structure requires two separate balances: that of the external forces and that of the internal forces. Externally sufficient reaction components must be developed by the supports. Internally, there must be an inherent capability for stability and



**Figure 1.22** Lack of internal resistance.

sufficient strength to do the work of transferring the applied loads to the supports.

As shown in Figure 1.23, there are three possible conditions for external stability. If support conditions are insufficient in type or number, the structure is externally unstable. If support conditions are just adequate, the structure is stable. If the supports provide an excess of the necessary conditions, the structure is probably stable, but may be indeterminate—not necessarily a bad quality, just a problem for achieving a simple investigation of structural behavior.

For internal stability, the structure must be formed, arranged, and fastened together to develop the necessary resistance. In the examples shown in Figure 1.22, the aluminum sheet was too thin for its size, the wood block had weak shear planes, and the frame lacked the necessary arrangement of members or type of joints. All three could be altered to make them more functional. As shown in Figure 1.24, the aluminum sheet can be braced with stiffening ribs, the solid-sawn wood block can be replaced with a laminated piece with alternate plies having their grain

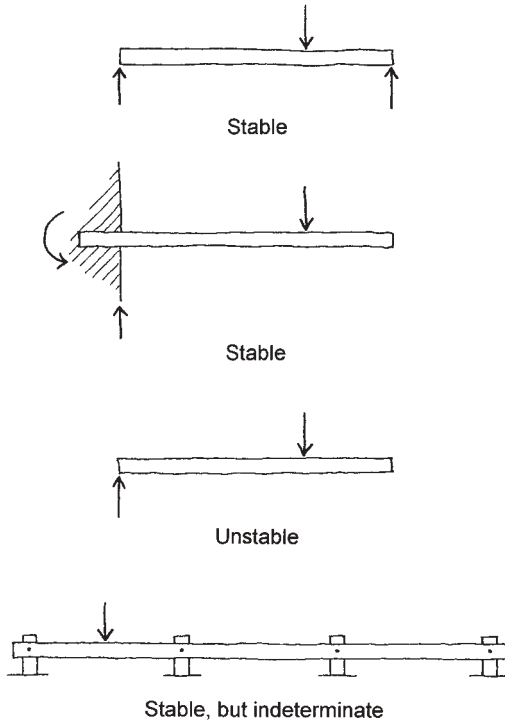


Figure 1.23 Stability analysis.

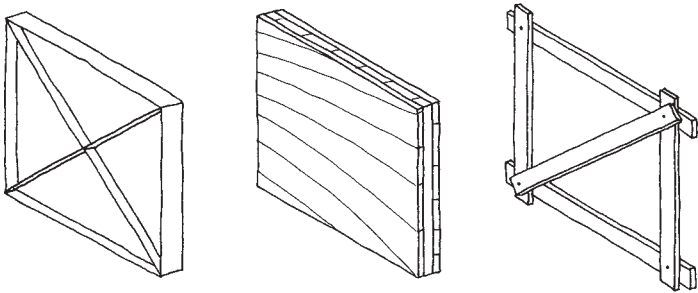


Figure 1.24 Alteration of internal conditions to improve structural resistance.

directions perpendicular to each other, and the frame can be stabilized by adding a diagonal member.

### 1.7 TYPES OF INTERNAL FORCE

Complex actions and effects consist of combinations of the following basic types of internal force. The simplest types to visualize are tension and compression, both of which produce simple stress and strain conditions, as shown in Figure 1.25.

#### Tension

The ability to withstand tension requires certain materials; stone, concrete, sandy soil, and wood perpendicular to its grain all have low resistance to tension. Stresses can become critical at abrupt changes in the cross section of a member, such as at a hole or a notch. Tension may serve to straighten members or to align connected members. Connections for transfer of tension are often more difficult to achieve than those for compression, requiring not simply contact (as with the stack of bricks), but some form of engagement or anchorage (see Figure 1.26).

#### Compression

Compression usually causes one of two types of failure: crushing or buckling. As discussed previously, buckling has to do with the relative stiffness of elements, while crushing is essentially a simple stress resistance

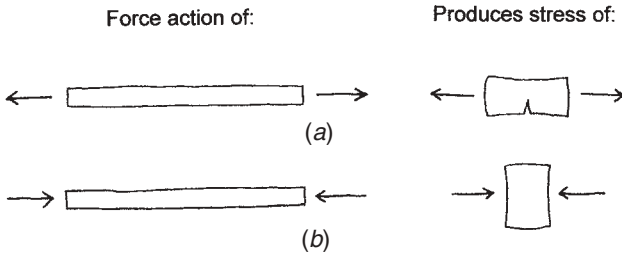
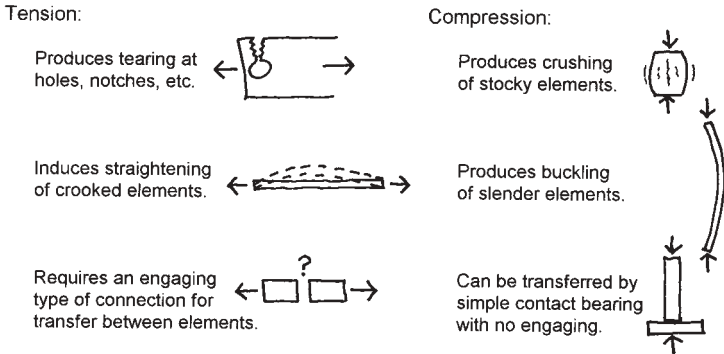


Figure 1.25 (a) Effects of tension. (b) Effects of compression.



**Figure 1.26** Considerations of tension and compression actions.

by the material. Actually, however, most building compression elements fall between a very slender (pure buckling) form and a very squat (pure crushing) form, and their behavior thus has some aspects of both forms of response. (See Figure 1.17 and consider the middle portion of the graph.) Compression can be transferred between elements by simple contact, as in the case of a footing resting on soil (see Figure 1.26). However, if the contact surface is not perpendicular to the compressive force, a side-slip failure might occur. Some form of engagement or restraint is thus usually desirable.

### Shear

In its simplest form, shear is the tendency for slipping of adjacent objects. This may occur at the joint between elements or within a material, such as a grain split in wood (see Figure 1.27). If two wooden boards in a floor are connected at their edges by a tongue-and-groove joint, shear stress is developed at the root of the tongue when one board is stepped on and the other is not. This type of shear also develops in bolts and hinge pins.

A more complex form of shear is that developed in beams. This can be visualized by considering the beam to consist of a stack of loose boards. The horizontal slipping that would occur between the boards in such a structure is similar to the internal shear that occurs in a solid beam. If the boards are glued together to form a solid beam, the horizontal slipping effect—beam shear—is what must be resisted at the glue joints.



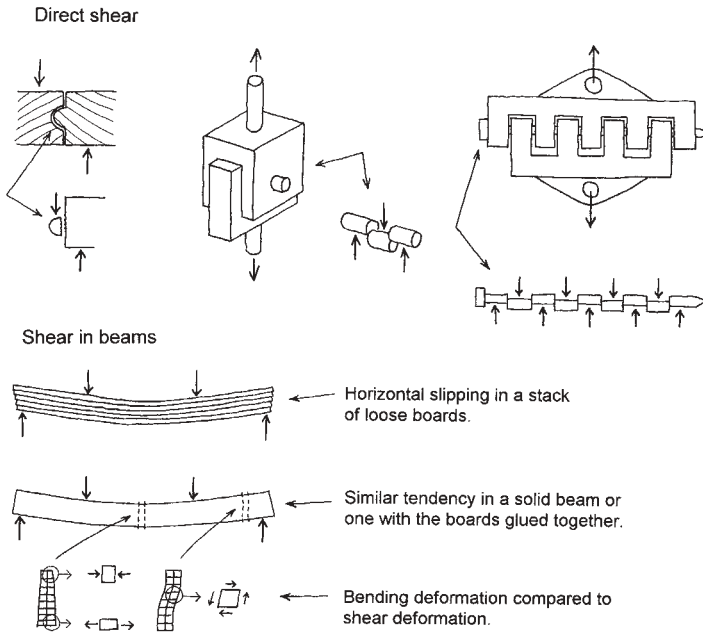


Figure 1.27 Effects of shear.

### Bending

Tension, compression, and shear are all produced by some direct force effect. Actions that cause rotation or curvature are of a different sort. If the action tends to cause straight elements to curve, it is called bending. If it tends to twist elements, it is called torsion (see Figure 1.28). When a

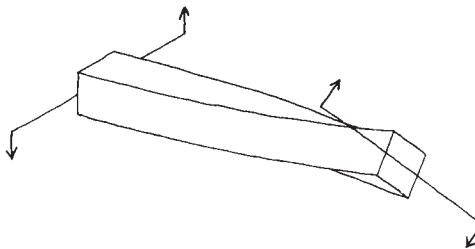
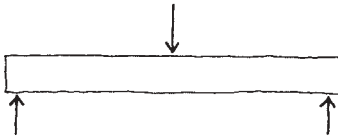


Figure 1.28 Effect of torsion.

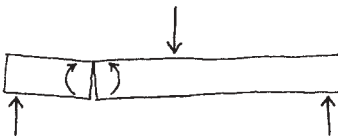
wrench is used to turn a bolt, bending is developed in the handle of the wrench, and torsion is developed in the bolt shaft.

Bending can be produced in a number of ways. A common situation occurs when a flat spanning structure is subjected to loads that act perpendicular to it. This is the basic condition of an ordinary beam. As shown in Figure 1.29, the internal force acting in the beam is a combination of bending and shear. Both of these internal stress effects produce lateral deformation of the straight, unloaded beam, called sag or deflection.

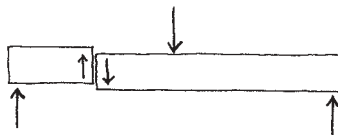
Bending involves a combination of force and distance, most simply visualized in terms of a single force and an operating moment arm (see Figure 1.30). It may also be developed by a pair of opposed forces, such as two hands on a steering wheel. The latter effect is similar to how a beam develops an internal bending resistance—by the opposing of compressive stresses in the top part of the beam to tension stresses in the bottom part.



Transverse load on a flat-spanning element ...

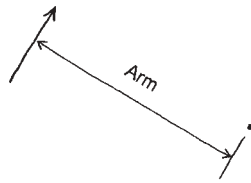


... produces internal turning action called bending ...

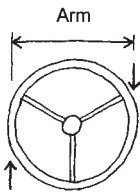


... and internal slicing action called shear.

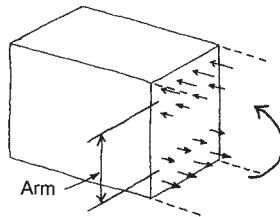
**Figure 1.29** Internal effects in beams.



Single force and a pivot



Opposed forces



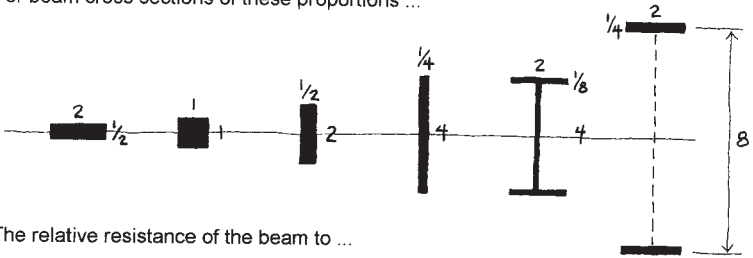
Opposed stresses in a beam

**Figure 1.30** Development of moments.

Since the development of moment is a product of force times distance, a given magnitude of force can produce more moment if the moment arm is increased. The larger the diameter of a steering wheel, the less force required to turn it—or, with a given limited force, the more moment it can develop. This is why a plank can resist more bending if it is turned on its edge as a joist. Figure 1.31 shows the effect of form change on a constant amount of material used for the cross section of a beam. For each shape, the numbers indicate the relative resistance to bending in terms of strength (as a stress limit) and stiffness (as a strain limit producing deflection).

In addition to the bending created when flat spanning members are transversely loaded, there are other situations in buildings that can produce bending effects. Two of these are shown in Figure 1.32. In the upper figures, bending is produced by a compression load not in line with the axis of the member or by a combination of compressive and lateral loading. In the lower figure, bending is transmitted to the columns through the rigid joints of the frame.

For beam cross sections of these proportions ...



The relative resistance of the beam to ...

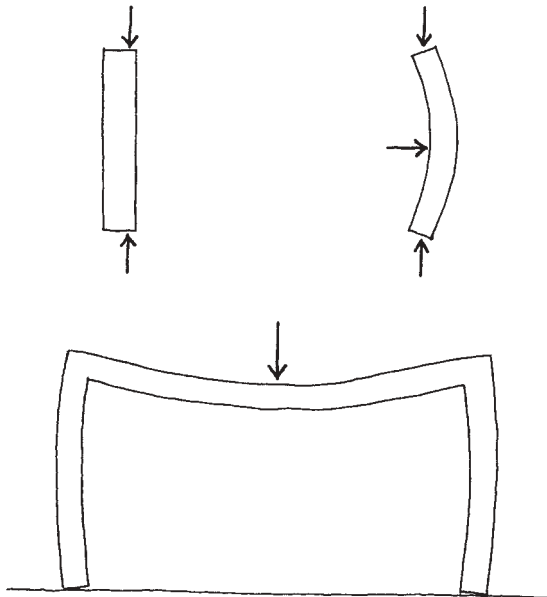
bending moment is

1            2            4            8            24            192

and to deflection is

1            4            16            64            192            3072

**Figure 1.31** Relation of cross-sectional geometry to bending resistance.



**Figure 1.32** Conditions resulting in internal bending.

For a cross section with a constant area, change in the shape of the cross section will affect torsional resistance as follows:



**Figure 1.33** Relation of cross-sectional geometry to torsional resistance.

### Torsion

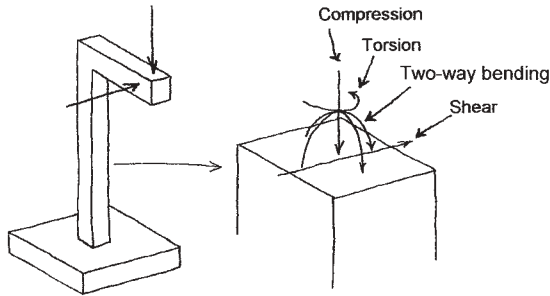
Torsion is similar to bending in that it is a product of force and distance. As with bending, the form of the cross section of the member resisting the torsion is a critical factor in establishing its strength and stiffness. A round hollow cylinder (pipe shape) is one of the most efficient forms for resistance to torsion. However, if the cylinder wall is slit lengthwise, its resistance is drastically reduced, being approximately the same as that for a flat plate made by flattening out the slit cylinder. Figure 1.33 shows the effect on torsional resistance of variations in the cross-sectional shape of a linear member with the same amount of material (area) in the cross section.

Often in designing structures, it is a wiser choice to develop resistance to torsion by bracing members against the twisting effect. Thus, the torsion is absorbed by the bracing, rather than by stresses in the member.

### Combinations of Internal Forces

The individual actions of tension, compression, shear, bending, and torsion can occur in various combinations and in several directions at a single point in a structure. For example, as illustrated previously, beams ordinarily sustain a combination of bending and shear. In the columns of the frame shown in the lower part of Figure 1.32, the loading on the beam will produce a combination of compression, bending, and shear. In the example shown in Figure 1.34, the loading will produce a combination of internal compression, shear, torsion, and bending in two directions.

Structures must be analyzed carefully for the various internal force combinations that can occur and for the critical situations that may



**Figure 1.34** Combined internal force effects.

produce maximum stress conditions and maximum deformations. In addition, the external loads often occur in different combinations, with each combination producing different internal force effects. This frequently makes the analysis of structural behaviors for design a quite laborious process, making us now very grateful for the ability to utilize computer-aided procedures in design work.

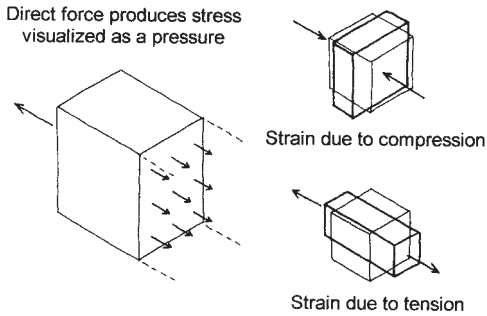
## 1.8 STRESS AND STRAIN

Internal force actions are resisted by stresses in the material of the structure. There are three basic types of stress: tension, compression, and shear. Tension and compression are similar in nature, although opposite in sign or sense. Both tension and compression produce a linear type of strain (shape change) and can be visualized as pressure effects perpendicular to the surface of a stressed cross section, as shown in Figure 1.35. Because of these similarities, both tension and compression are referred to as direct stresses, one considered positive and the other negative.

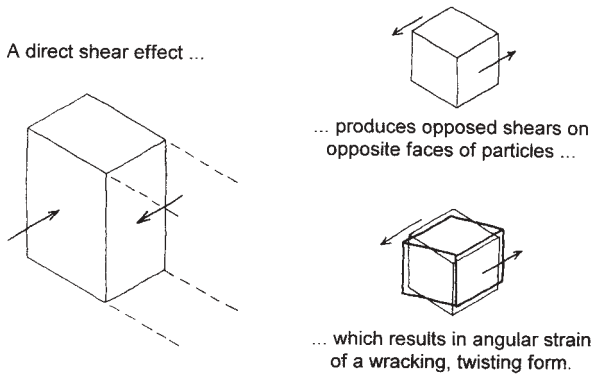
Shear stress occurs in the plane of a cross section and is similar to a sliding friction effect. As shown in Figure 1.36, strain due to shear stress is of a different form from that due to direct stress; it consists of an angular change rather than a linear shortening or lengthening.

### Stress-Strain Relations

Stress and strain are related not only in the basic forms they take, but in their actual magnitudes. Figure 1.37 shows the relation between stress and



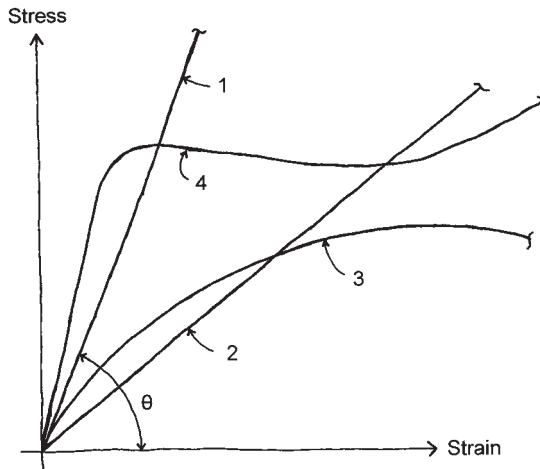
**Figure 1.35** Direct stress and strain.



**Figure 1.36** Shear stress and strain.

strain for a number of different materials. The form of such a graph illustrates various aspects of the nature of structural behavior of the materials.

Curves 1 and 2 represent materials with a constant proportionality of the stress and strain magnitudes. For these materials, a quantified relationship between stress and strain can be described simply in terms of the slope or angle of the straight line graph. This relationship is commonly expressed as the tangent of the angle of the graph and is called the *modulus of elasticity* of the material. The higher the value of this modulus—that is, the steeper the slope of the graph—the stiffer the material. Thus, the material represented by curve 1 in the illustration is stiffer than the material represented by curve 2.



**Figure 1.37** Stress and strain relationships.

For direct stress of tension or compression, the strain is measured as a linear change, and the modulus is called the direct stress modulus of elasticity. For shear stress, the strain is measured as an angular change, and the resulting modulus is called the shear modulus of elasticity.

Some materials, such as glass and very high-strength steel, have a constant modulus of elasticity for just about the full range of stress up to failure of the material. Other materials, such as wood, concrete, and plastic, have a curved form for the stress-strain graph (curve 3 in Figure 1.37). The curved graph indicates that the value for the modulus of elasticity varies continuously for the full range of stress.

The complex shape of curve 4 in Figure 1.37 is the characteristic form for a so-called *ductile* material, such as low-grade steel of the type ordinarily used for beams and columns in buildings. This material responds elastically at a low level of stress, but suddenly deforms excessively at a level of stress described as its yield point. However, fracture does not usually occur at this level of stress, but rather at a higher level after the material reaches a certain limiting magnitude of yielding strain. This predictable yield phenomenon and the secondary reserve strength are used to predict ultimate load capacities for steel frames, as well as for concrete structures that are reinforced with ductile steel rods.

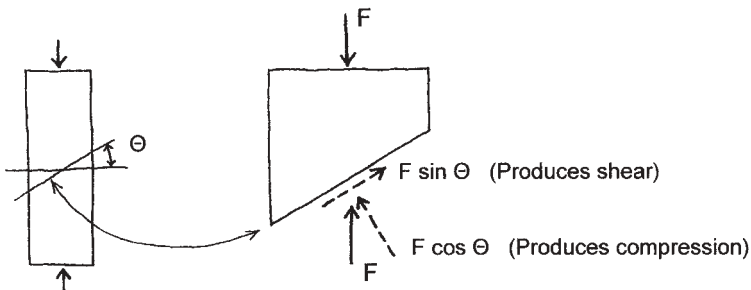


## Stress Combinations

Stress and strain are three-dimensional phenomena, but for simplicity, they are often visualized in linear or planar form. As shown in Figure 1.35, direct stress of compression in a single direction results in strain of shortening of the material in that direction. However, if the volume of the material remains essentially unchanged—which it usually does—there will be a resulting effect of lengthening (or pushing out) at right angles to the compression stress. This implies the development of a tension effect at right angles to the compression, which in some materials may be the real source of failure, as is the case for tension-weak concrete and plaster. Thus, a common form of failure for concrete in compression is by lateral bursting at right angles to the compression load.

If direct stress is developed in a linear member, as shown in Figure 1.38, the pure direct stress occurs only on sections at right angles to the direct force loading, called cross sections. If stress is considered on a section at some other angle (called an oblique section), there will be a component of shear on the section. If the material is weak in shear (such as wood parallel to its grain), this angular shear stress effect may be more critical than the direct stress effect.

Although simple linear tension and compression forces produce direct, linear stresses, shear stress is essentially two-dimensional, as shown in Figure 1.39. The direct effect of a shear force is to produce shear stresses that are parallel to the force (on faces *a* and *b* in Figure 1.39*a*). These opposed stresses in the material produce a rotational effect, which must be balanced by other opposed stresses (at faces *c* and *d* in Figure 1.39*b*). Thus, whenever shear stress exists within a structure, there is always an equal magnitude of shear stress at right angles to it. An example



**Figure 1.38** Stress on a cross section not at right angles to the active force.

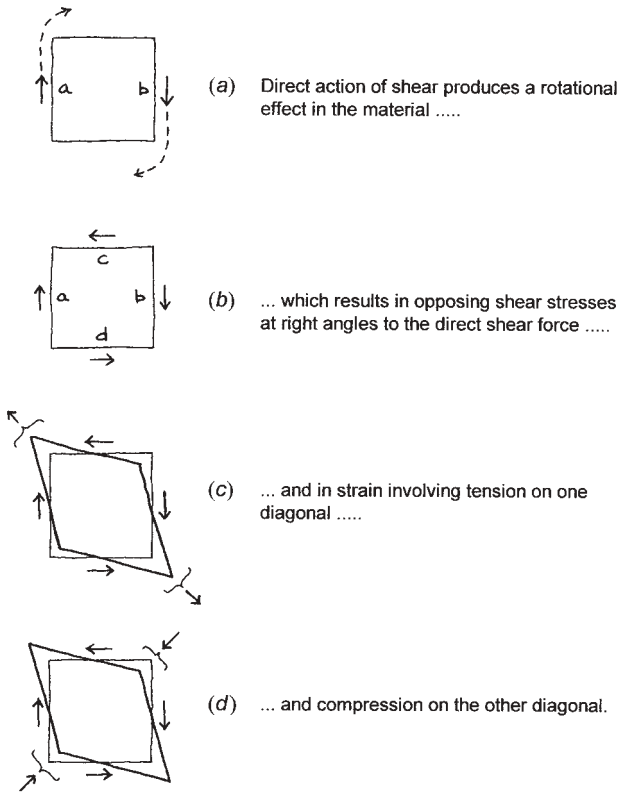


Figure 1.39 Effects of shear.

of this is the stack of loose boards used as a beam, as shown in Figure 1.27. The shear failure in this case is a horizontal slipping between the boards, even though the shear force is induced by vertical loading.

As shown in Figures 1.39c and d, the combination of the mutually perpendicular shear stresses produces a lengthening of the material on one diagonal and a shortening on the other diagonal. This implies the development of tension on one diagonal and compression on the other diagonal, at right angles to the tension. In some cases, these diagonal stresses may be more critical than the shear stresses that produce them. In concrete, for example, failure due to shear stress is usually actually a diagonal tension stress failure, as this is the weakest property of the material.

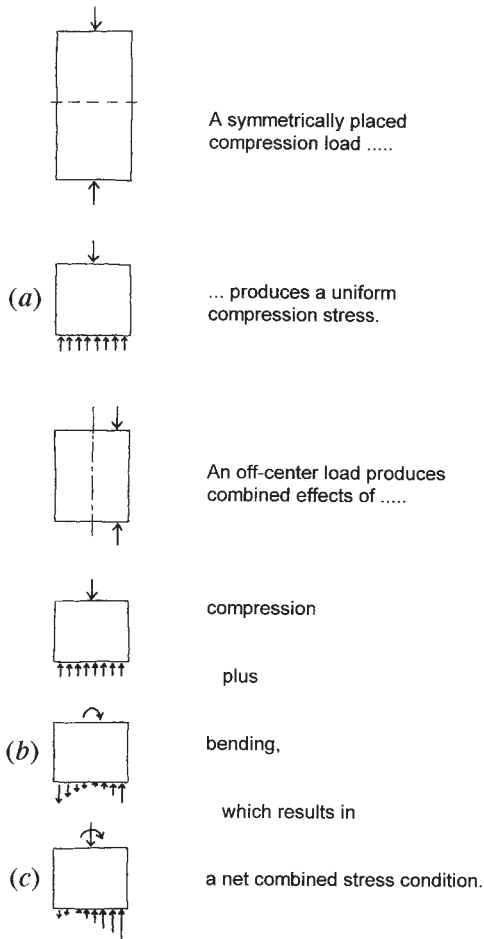
On the other hand, high shear in the web of a steel beam may result in diagonal compression buckling of the thin web.

Separately produced direct stresses in a single direction may be summed algebraically at a given point in a structure. In the case of the column shown in Figure 1.40, the compression load produces a direct compression stress on a cross section, as shown at Figure 1.40*a*, if the load is placed so as not to produce bending. If the load is off-center on the column, the stress conditions will be modified by the addition of bending stresses on the cross section, as shown in Figure 1.40*b*. The true net stress condition at any point on the cross section will thus be the simple addition of the two stress effects, with a combined stress distribution possible as shown in Figure 1.40*c*.

A more complex situation is the combination of direct stresses and shear stresses. Figure 1.41*a* shows the general condition at a point in the cross section of a beam where the net stress consists of a combination of the direct stress due to bending (tension or compression) and shear stress. These stresses cannot simply be added as they were for the column. What can be combined are the direct stress due to bending and the direct diagonal stress due to shear, as shown in Figure 1.41*b*. Actually, because there are two diagonal stress conditions, there will be two combinations—one producing a maximum effect and the other a minimum effect, as shown in Figure 1.41*c*. These two stress limits will occur in mutually perpendicular directions.

There is also a net combined shear stress, as shown in Figure 1.41*d*. This is the combination of the direct shear stress and the diagonal shear stress due to the direct stress. Since the direct shear stress is at right angles (vertically and horizontally) and the shear stress due to direct stress is on a  $45^\circ$  plane, the net maximum shear will be at some angle between these two. This angle will be closer to a right angle when the direct shear is larger and closer to a  $45^\circ$  position when the direct stress is larger.

Another stress combination is that produced by triaxial stress conditions. An example of this is a confined material subjected to compression, such as air or liquid in a piston chamber, as shown in Figure 1.42. In addition to being compressed by the active compressing force (the piston), the material is squeezed laterally by the other material around it. The net effect on the confined material is a three-way push, or triaxial compression. For materials with little or no tension resistance, such as air, water, or dry sand, this is the only situation in which they can resist compression. Thus, a sandy soil beneath a footing can develop resistance in the form of vertical soil pressure because of the confinement of the soil around it and above it.



**Figure 1.40** Combined direct stresses.

For visualization purposes, it is common to reduce complex structural actions to their component effects. These simpler individual effects can thus be analyzed more clearly and simply, and the results combined with the effects of the other components. In the end, however, care must be taken to include all the components for a given situation.

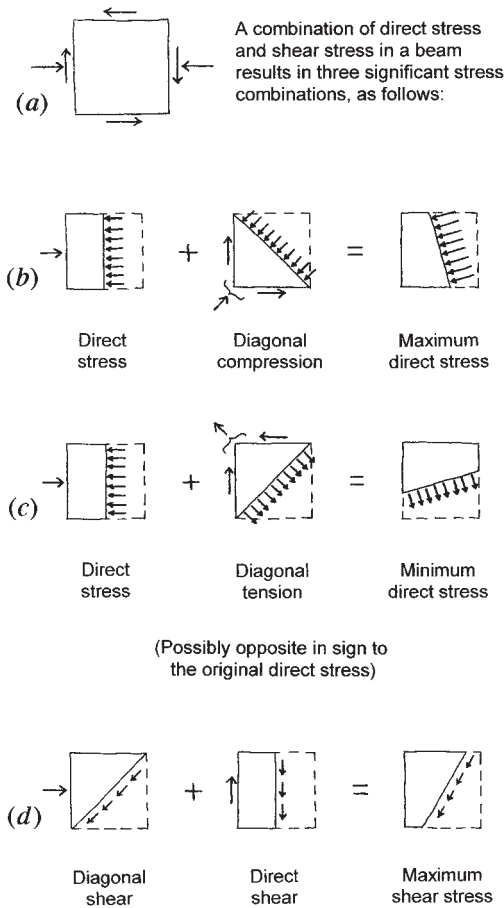
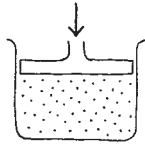


Figure 1.41 Combined shear stress and direct stress.

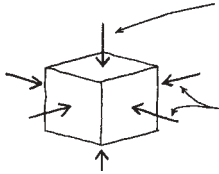
### Thermal Stress

The volumes of materials change with temperature variation, increasing as temperatures rise and decreasing when they fall. This phenomenon creates a number of problems that must be dealt with in building design.

The form of objects determines the basic nature of significant dimensional changes. As shown in Figure 1.43, the critical directions of



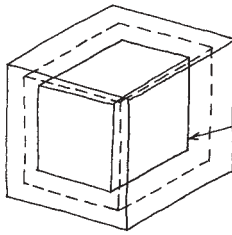
When compressed, a confined material develops reactive stresses resulting in a multiaxial stress condition.



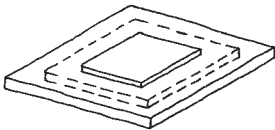
Active stress developed by the compressing force (piston).

Reactive stresses resulting from the push against the confinement.

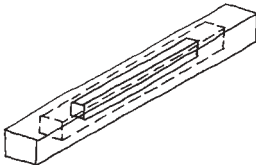
**Figure 1.42** Development of stress in a confined material.



Thermal change causes change in the volume of solids, manifested as contraction or expansion.



For planar elements, the significant dimensional changes are two-dimensional.



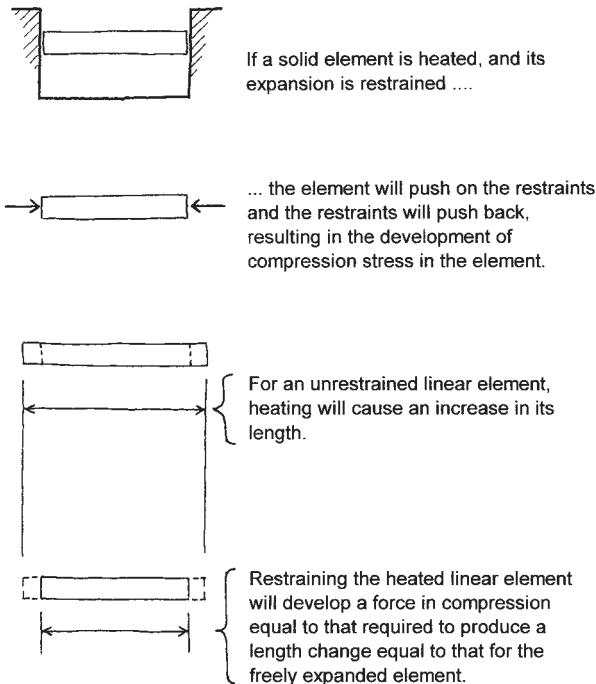
For linear elements, the significant dimensional changes are linear, or simply change in length.

**Figure 1.43** Effects of thermal change on solid objects.

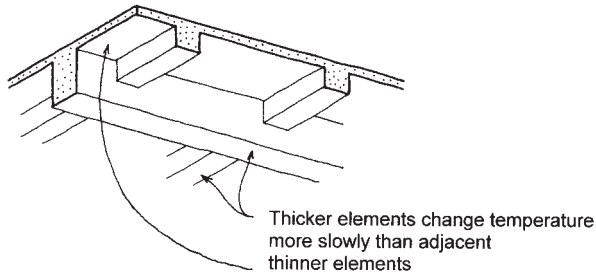
movement depend on whether the object is essentially linear, planar (two-dimensional), or three-dimensional. For a linear object (beam, column, etc.), the significant change is in its length; significant concerns are those for very long objects, especially in climates with a considerable temperature range.

Planar objects, such as wall panels and large sheets of glass, expand in a two-dimensional manner. Attachments and constraints by other construction must allow for thermal movements. Three-dimensional movements are mostly dealt with by providing for component movements of a linear or two-dimensional nature.

If thermal expansion or contraction is resisted, stresses are produced. Figure 1.44 shows a linear structural member in which length change is



**Figure 1.44** Effect of thermal change on a constrained element.



**Figure 1.45** Critical stress effects resulting from differential thermal movements.

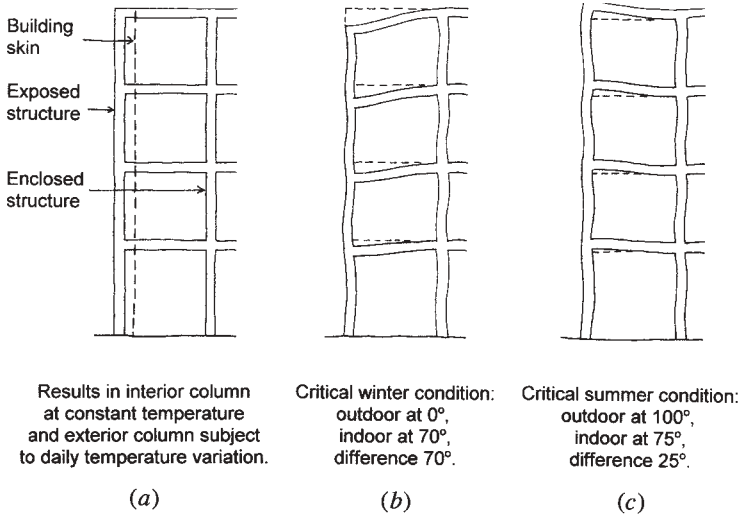
constrained. If the temperature is raised, the member will push outward against the restraints, developing internal compression as the constraints push back. This results in an external compression force on the member, in the same manner as a load applied to a column. With quantified values known for the thermal expansion coefficient and the stress-strain relationship for the material, the compressive stress developed in the member can be determined.

Another type of thermal problem is that involving differential movement of attached parts of the construction. Figure 1.45 shows a common situation in which a cast concrete structure consists of elements of different mass or thickness. If exposed to temperature change, the thinner parts will cool down or warm up more quickly than the thicker parts to which they are attached by the continuous casting process. The result is that the thinner parts are restrained in their movements by the thicker parts, which induces stresses in all the parts. These stresses are most critical for the thinner parts and at the joints between the parts.

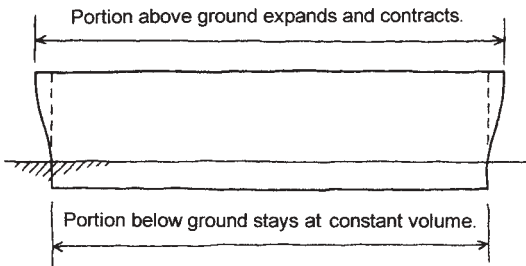
Another problem of differential thermal movements occurs between the exterior surface and the interior mass of a building. As shown in Figure 1.46, the exposed skin—as well as any exposed structural members—will tend to move in response to the changes in outdoor temperatures, while the interior elements of the construction tend to remain at a relatively constant, comfort-level temperature. For a multistory building, this effect accumulates toward the top of the building and can result in considerable distortions in the upper levels of the structure.

A similar problem occurs with long buildings in which the part above ground is exposed to the weather, while that buried in the ground remains at a relatively constant temperature throughout the year (see Figure 1.47).





**Figure 1.46** Effect of exposure conditions of the structure on development of thermally induced stress and strain. (a) Conditions resulting in major exposure of the exterior wall structure, but enclosure of the interior structure. (b) In the winter (outside at 0°F, interior at 70°F, differential of 70°F), the exterior columns become shorter than the interior, resulting in the deformations shown. (c) In the summer (outside at 100°F, inside at 75°F, differential of 25°F), the exterior columns become longer than the interior, resulting in the deformations shown.



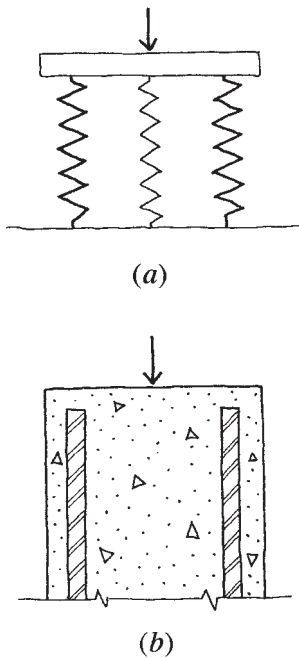
**Figure 1.47** Thermal effects in partly underground buildings.

The simple solution here is to provide construction joints periodically in the building length that literally create separated masses of the building, each of a controlled, shorter length.

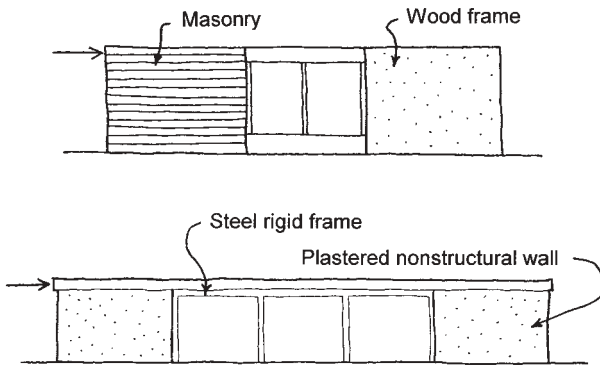
### Composite Structures

When structural elements of different stiffness share a load, they develop resistance in proportion to their individual stiffnesses. As shown in Figure 1.48*a*, if a group of springs share a load that shortens all of the springs the same amount, the portion of the load resisted by the stiffer springs will be greater, since it takes a greater effort to shorten them.

Another common type of composite structure occurs when concrete is reinforced with steel rods, as shown in Figure 1.48*b*. When a load is applied to such an element (called a composite structure), the stiffer material (steel in this case) will carry a higher portion of the load. In this



**Figure 1.48** Load sharing in composite structures. (a) A group of springs of varying stiffness. (b) Steel-reinforced concrete.



**Figure 1.49** Load sharing by elements of different construction.

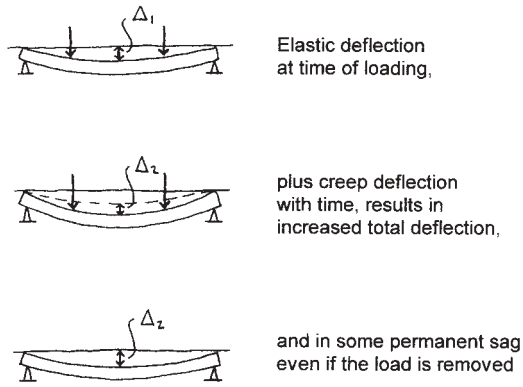
manner, a relatively small percentage of steel in a reinforced concrete member can be made to carry a major part of the load, since steel has on average around 10 times the stiffness of structural grade concrete.

A situation somewhat similar to this occurs when the building as a whole is distorted by loads, such as the horizontal effects of wind and earthquakes. Figure 1.49 shows two examples of this, the first being a building with solid walls of masonry and wood frame construction in the same exterior surface. As a bracing wall for horizontal loads, the much stiffer masonry will tend to take most of the load. In this case, the wood framed wall may be virtually ignored for its structural resistance, although any effects of the lateral distortion must be considered.

The second example in Figure 1.49 involves a steel frame in the same plane as relatively stiff walls. Even though the framed walls may be less strong than the steel frame, they will likely be much stiffer; thus, they will tend to absorb a major portion of the lateral load. The solution in this case is to either make the walls strong enough for the bracing work, or to make the steel frame stiff enough to protect the walls and actually do the bracing work.

## Time-Related Stress and Strain

Some stress and strain phenomena are time related. Concrete is subject to an effect called creep (see Figure 1.50), in which the material sustains a progressive deformation when held at a constant stress over a long time. These deformations are added to those produced normally by the initial



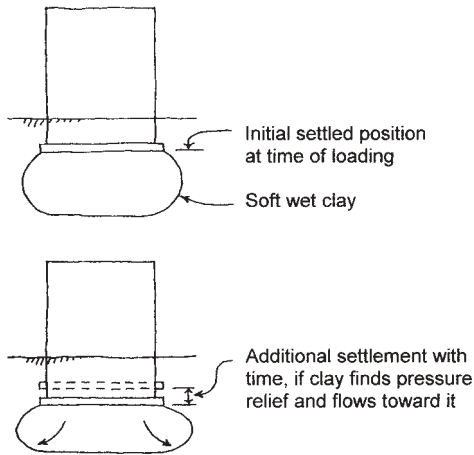
**Figure 1.50** Effect of creep.

loading. Additionally, unlike the initial deformations, they remain permanent, similar to the long-term sag of wood beams.

Creep does not affect the stress resistance of concrete, but does result in some redistribution of stresses between the concrete and its steel reinforcing. Since the steel does not creep, it effectively becomes increasingly stiffer in relation to the progressively softening concrete. This makes the steel even greater in its capability of carrying a major part of the load in the composite structure.

Soft, wet clay soils are subject to a time-related flow effect, similar to the slow oozing of toothpaste from a tube as it is squeezed. If the soil mass is well constrained (similar to putting the cap back on the toothpaste tube), this effect can be arrested. However, as long as there is somewhere for the clay to ooze toward, and the pressure on it is maintained, the flow will continue. Instances of buildings that continue to settle over many years have occurred with this soil condition (see Figure 1.51).

Another time-related stress problem occurs when structures are repeatedly loaded and unloaded. The effect of people walking, of wind and earthquakes, and of machinery rocking on its supports are cases of this loading condition in buildings. Some materials may fail from the fatigue effects of such loadings. However, a more common problem is that of loosening of connections or the progressive development of cracks that were initially created by other effects.



**Figure 1.51** Time-related settlement.

## 1.9 DYNAMIC EFFECTS

Vibrations, moving loads, and sudden changes in the state of motion, such as the jolt of rapid braking or acceleration, cause forces that result in stresses and strains in structures. The study of dynamic forces and their effects is very complex, although a few of the basic concepts can be illustrated simply.

For structural investigation and design, a significant distinction between static and dynamic effects has to do with the response of the structure to the loading. If the principal response of the structure can be effectively evaluated in static terms (force, stress, linear deformation, etc.), the effect on the structure is essentially static, even though the load may be time-dependent in nature. If, however, the structure's response can be effectively evaluated only in terms of energy capacity, work done, or cyclic movement, the effect of the load is truly dynamic in character.

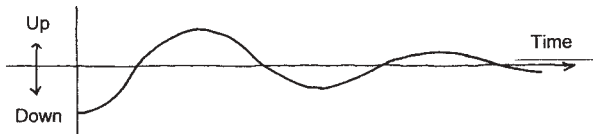
A critical factor in the evaluation of dynamic response is the fundamental period of the structure. This is the time required for one full cycle of motion in the form of a bounce or a continuing vibration. The relation of this time to the time of buildup of the load is a major factor in determining that a structure experiences a true dynamic response. The time of

the period of a structure may vary from a small fraction of a second to several seconds, depending on the structure's size, mass (weight), and stiffness, as well as on support constraints and the presence of damping effects.

In the example in Figure 1.52, a single blow from the hammer causes the board to bounce in a vibratory manner described by the time-motion graph. The elapsed time for one full cycle of this motion is the fundamental period of the board. If a 100-lb load is applied to the end of the board by slowly stacking bricks on it, the load effect on the board is static. However, if a 100-lb boy jumps on the end of the board, he will cause both an increase in deflection and a continued bouncing of the board, both of which are dynamic effects. If the boy bounces on the end of the board with a particular rhythm, he can cause an extreme up and down motion of the board. He can easily find the rate of bouncing



A single hammer blow to the board causes it to vibrate as shown in the graph below.

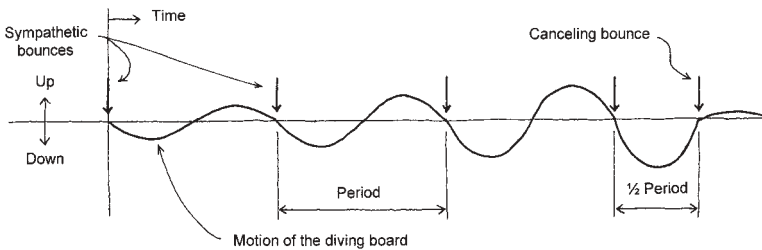


A slowly applied static load does not cause the board to vibrate.



But the same amount of load, suddenly applied, causes an increased deflection as well as continued vibration.

**Figure 1.52** Dynamic effects on elastic structures.



**Figure 1.53** Motion of the diving board.

required to do this by experimenting with different rhythms. He may also find the exact variation in his bouncing that will result in an almost complete, instantaneous stop of the board's motion. As shown in the graph in Figure 1.53, the reinforcing bouncing that generates increasing motion of the board corresponds to the fundamental period of the board. To stop the board, the boy merely cuts the time of his bounce in half, thus meeting the board on its way up.

If the boy bounces on the board once and then jumps off, the board will continue to bounce in ever-decreasing magnitudes of displacement until it finally comes to rest. The cause of this deterioration of the board's motion is called damping. It occurs because of energy dissipated in the board's spring mounting and in air friction, as well as because of any general inefficiencies in the movement of the board. If no damping were present, the boy's sympathetic bouncing could eventually cause damage to the board.

Dynamic forces on structures result from a variety of sources and can create problems in terms of the total energy delivered to the structure or in the form of the movements of the structure. Excessive energy loading can cause structural damage or total collapse. Movements may result in loosening of connections, toppling of vertical elements, or simply in highly undesirable experiences for building occupants.

Design for dynamic response usually begins with an evaluation of potential dynamic load sources and their ability to generate true dynamic effects on the structure. Once the full nature of the dynamic behavior is understood, measures can be taken to manipulate the structure's dynamic character or to find ways to reduce the actual effects of the dynamic loading itself. Thus, it may be possible to brace a structure more securely against movements due to an earthquake, but it may also be possible to

dissipate some of the actual movement by placing a motion-absorbing separator between the building and the ground.

### **1.10 DESIGN FOR STRUCTURAL RESPONSE**

In the practice of structural design, the investigation of structural response to loads is an important part of the design process. To incorporate this investigation into the design work, the designer needs to develop a number of capabilities, including the following:

1. The ability to visualize and evaluate the sources that produce loads on structures.
2. The ability to quantify the loads and the effects they have on structures.
3. The ability to analyze a structure's response to the loads in terms of internal forces and stresses and strains.
4. The ability to evaluate the structure's safe limits for load-carrying capacity.
5. The ability to manipulate the variables of material, form, dimensions, and construction details for the structure in order to maximize its structural response.

For any structure, it is necessary to perform some computations in order to demonstrate the existence of an adequate margin of safety for a given loading. However, the complete design of a structure must also incorporate many other considerations in addition to structural performance. A successful structure must be structurally adequate, but it must also be economical, feasible for construction, and must generally facilitate the overall task it serves as part of the building construction. It must also be fire-resistant, time-enduring, maybe weather-resistant, and whatever else it takes to be a working part of the building throughout the life of the building.

#### **Aspects of Structural Investigation**

The professional designer or investigator uses all the practical means available for accomplishment of the work. In this age, mathematical



modeling is greatly aided by the use of computers. However, routine problems (that is, 98% of all problems) are still often treated by use of simple hand computations or by reference to data in handbook tables or graphs.

The purpose of this book is essentially educational, so the emphasis here is on visualization and understanding, not necessarily on efficiency of computational means. Major use is made of graphical visualization, and readers are strongly encouraged to develop the habit of using such visualization. The use of sketches as learning and problem-solving aids cannot be overemphasized. Four types of graphical devices are especially useful: the free-body diagram, the cut section, the exaggerated profile of the load-deformed structure, and the graphical plot of critical equations.

A free-body diagram consists of a picture of any isolated physical element that shows the full set of external forces that operate on that element. The isolated element may be a whole structure or any fractional part of it. Consider the structure shown in Figure 1.54. Figure 1.54*a* shows the entire structure, consisting of attached horizontal and vertical elements (beams and columns) that produce a planar rigid frame bent. This may be one of a set of such frames comprising a building structure. The free-body diagram in Figure 1.54*a* represents the entire structure, with forces external to it represented by arrows. The arrows indicate the location, sense, and direction of each external force. At some stage of investigation, numbers may be added indicating the magnitude of these forces. The forces shown include the weight of the structure, the horizontal force of wind, and the net forces acting at the points of support for the frame.

Shown in Figure 1.54*b* is a free-body diagram of a single beam from the framed bent. Operating externally on the beam are its own weight plus the effects of interaction between the beam and the columns to which it is attached. These interactions are not visible in the free-body diagram of the full frame, so one purpose for the diagram of the single beam is simply the visualization of the nature of these interactions. It may now be observed that the columns transmit to the ends of the beams a combination of vertical and horizontal forces plus rotational bending actions. The observation of the form of these interactions is a necessary first step in a full investigation of this beam.

Figure 1.54*c* shows an isolated portion of the beam length, produced by slicing vertical planes a short distance apart and removing the portion

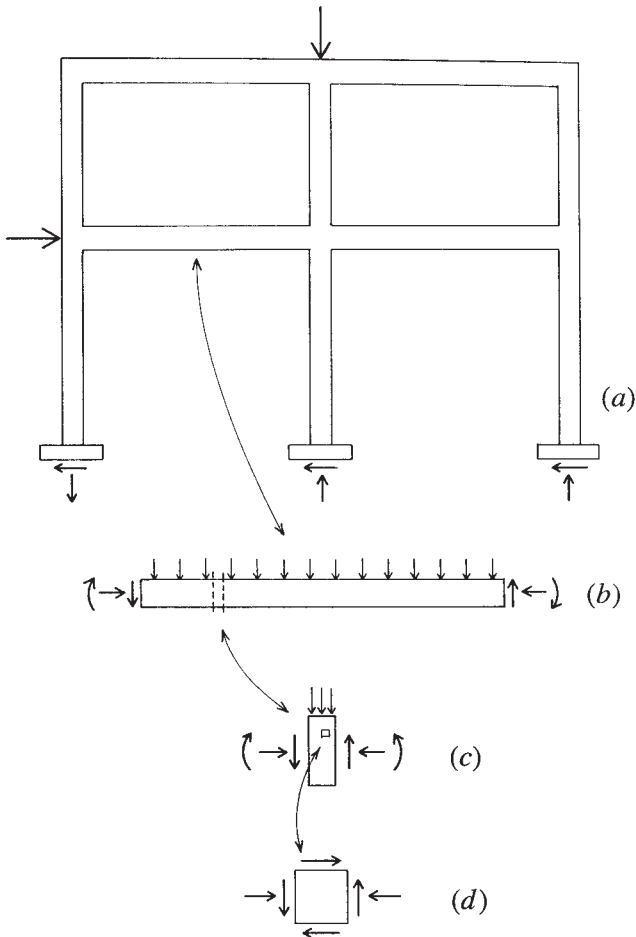
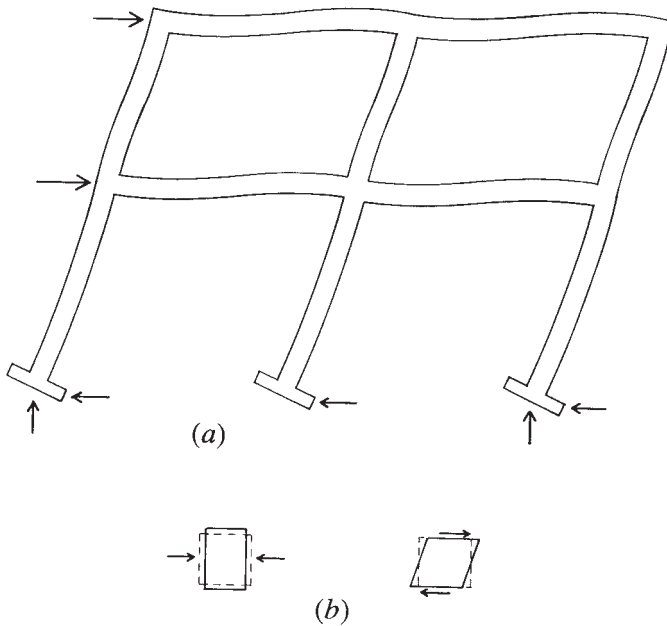


Figure 1.54 Free-body diagrams.

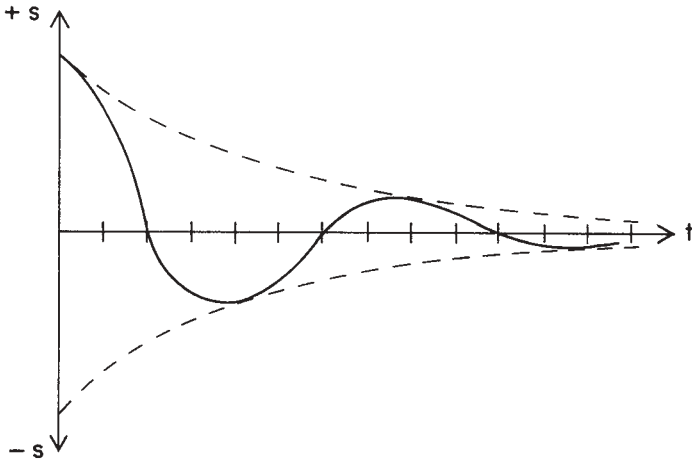
between them. Operating on this free body are its own weight and the actions of the of the beam segments on the opposite sides of the slicing planes; that is, the effects that hold this segment in place in the uncut beam. This slicing device, called a cut section, is used to visualize the internal force actions in the beam and is a first step in the investigation of the stresses that relate to the internal forces.



**Figure 1.55** Visualization of structural deformations.

Finally, in Figure 1.54*d* is shown a tiny particle of the material of the beam, on which the external effects are those of the adjacent particles. This is the basic device for visualization of stress. In the example, the particle is seen to be operated on by a combination of vertical shear (and its horizontal complement) and horizontally directed compression.

Figure 1.55*a* shows the exaggerated deformed profile of the same bent under wind loading. The overall form of lateral deflection of the bent and the character of bending in each member can be visualized from this figure. As shown in Figure 1.55*b*, the character of deformation of segments and particles can also be visualized. These diagrams are very helpful in establishing the qualitative nature of the relationships between force actions and overall shape changes or between stresses and strains. Quantitative computations often become considerably abstract in their operation, but these diagrams are real exercises in direct visualization of behavior.



**Figure 1.56** Displacement versus elapsed time plot of a cyclic (harmonic) motion.

For both visualization and quantification, considerable use is made of graphical plots of mathematical expressions in this book. Figure 1.56 shows the form of damped vibration of an elastic spring. The graph consists of a plot of the variation of displacement (+ or - $s$ ) of the spring from its neutral position as a function of elapsed time  $t$ . This is a plot of the equation

$$s = \left( \frac{1}{e^t} \right) [P \sin(Qt + R)]$$

which describes the function mathematically but not visually. The graph helps us to literally *see* the rate of decline of the vibration (damping effect) and the specific location of the spring at any given point in time. Only mathematicians can see these things from an equation; for the rest of us, the graph is a big help.

# 2

---

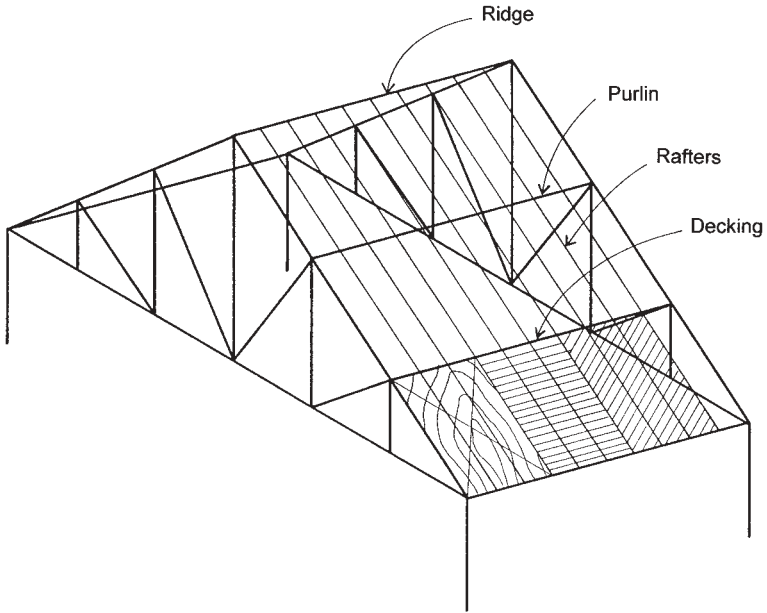
## FORCES AND FORCE ACTIONS

---

The preceding chapter provided an overview of the world of structural analysis as an activity for the support of design of building structures. This chapter begins a more deliberate study of the basic applications of physics and mathematics to the real work of structural analysis. This study begins with a consideration of forces and their actions.

### **2.1 LOADS AND RESISTANCE**

Loads deriving from the tasks of a structure produce forces. The tasks of the structure involve the transmission of the load forces to the supports for the structure. Applied to the structure, these external load and support forces produce a resistance from the structure in terms of internal forces that resist changes in the shape of the structure. In building structural systems, such as that shown in Figure 2.1, load forces are passed from element to element, here from deck to rafter to purlin to truss to column to column support.



**Figure 2.1** Developed system for generation of a roof structure. Columns support spanning trusses that in turn support a combination of purlins, rafters, and decking to define the roof surface. Forces flow through the system, passing from the deck to the columns.

A first task for investigation of structural behavior is the consideration of the nature of individual forces, of the combinations they occur in, and of the equilibrium (balance) of all the forces that affect an individual structure. Equilibrium is an assumed condition based on not wanting the structure go anywhere. That is, it may deform slightly, but it is supposed to stay in place. Thus, when we add up all the operating forces on a structure, we should get a net total of zero force.

The field of mechanics in the basic science of physics provides the fundamental relationships for dealing with forces and their actions. Using those relationships to solve practical problems involves some applications of mathematics—from simple addition to advanced calculus, depending on the complexity of the problems. Here we assume the reader has some familiarity with basic physics and a reasonable understanding

of arithmetic, geometry, elementary algebra, and the first week or so of a trigonometry course. Having more background in mathematics will be useful for advanced study beyond this book, but will not really help much here.

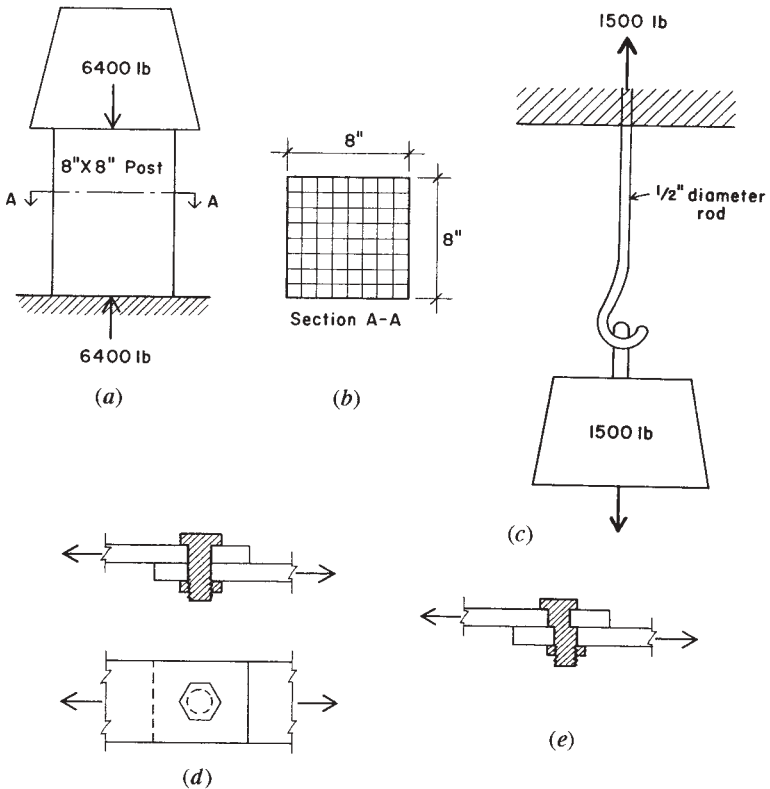
As the reader has already noticed, we use illustrations considerably in this book. In the work that follows, these are also used as part of the illumination of the ideas and the steps for analysis procedures. There are thus three components of study: literal (text description), visual (the book's or the reader's sketches), and mathematical (demonstrations of computations). It will work best for the reader to be fluent in all three components of the study, but some shortcomings in the mathematical area may be compensated for if the words and pictures are fully understood first.

## 2.2 FORCES AND STRESSES

The idea of force is one of the fundamental concepts of mechanics and does not yield to simple, precise definition. An accepted definition of force is that which produces, or tends to produce, motion or a change in the state of motion of objects. A type of force is the effect of gravity, by which all objects are attracted toward the center of the earth.

What causes the force of gravity on an object is the mass of the object, and in U.S. units, this force is quantified as the weight of the body. Gravity forces are thus measured in pounds (lb), or in some other unit such as tons (T) or kips (one kilopound, or 1000 pounds). In the metric (or SI) system, force is measured in a more purely scientific manner as directly related to the mass of objects; the mass of an object is a constant, whereas weight is proportional to the precise value of the acceleration of gravity, which varies from place to place. Force in metric units is measured in newtons (N), kilonewtons (kN), or Meganewtons (mN), whereas weight is measured in grams (g) or kilograms (kg).

Figure 2.2a represents a block of metal weighing 6400 lb supported on a wooden post having an  $8 \times 8$  in. cross section. The wooden post is, in turn, supported on a base of masonry. The gravity force of the metal block exerted on the wood is 6400 lb, or 6.4 kips. Ignoring its own weight, the wooden post in turn transmits a force of equal magnitude to the masonry base. If there is no motion (a state described as equilibrium), there must be



**Figure 2.2** Direct force action and stress.

an equal upward force developed by the supporting masonry. Thus, the wooden post is acted on by a set of balanced forces consisting of the applied (or active) downward load of 6400 lb and the resisting (called reactive) upward force of 6400 lb.

To resist being crushed, the wooden post develops an internal force of compression through stress in the material, stress being defined as internal force per unit area of the post's cross section. For the situation shown, each square inch of the post's cross section must develop a stress equal to  $6400/64 = 100$  lb/sq. in. (psi). See Figure 2.2*b*.



## 2.3 TYPES OF FORCES

External forces may result from a number of sources, as described in Section 1.1. For the moment, we are treating only static forces, and thus, only static force effects on responding objects. Direct action of static forces produces internal force responses of compression, tension, or shear. The metal weight in Figure 2.2 represents a compressive force, and the resulting stresses in the wooden post are compressive stresses.

Figure 2.2*c* represents a 0.5-in. diameter steel rod suspended from an overhead support. A weight of 1500 lb is attached to the lower end of the rod, exerting an external tensile force on the rod. The cross-sectional area of the rod is  $\pi R^2 = 0.31416(0.25)^2 = 0.196 \text{ in.}^2$ , where  $R$  is the radius. Hence, the tensile stress in the rod is  $1500/0.196 = 7653 \text{ psi}$ .

Now consider the two steel bars held together by a 0.75-in. diameter bolt, as shown in Figure 2.2*d*, and subjected to a tension force of 5000 lb. The tension force in the bars becomes a shear force on the bolt, described as a direct shear force. There are many results created by the force in Figure 2.2*d*, including tensile stress in the bars and bearing on the sides of the hole by the bolt. For now, we are concerned with the slicing action on the bolt (Figure 2.2*e*), described as direct shear stress. The bolt cross section has an area of  $3.1416(0.375)^2 = 0.4418 \text{ in.}^2$ , and the shear stress in the bolt is thus equal to  $5000/0.4418 = 11,317 \text{ psi}$ . Note that this type of stress is visualized as acting in the plane of the bolt cross section, as a slicing or sliding effect, while both compressive and tensile stresses are visualized as acting perpendicular to a stressed cross section.

## 2.4 VECTORS

A quantity that involves magnitude, direction (vertical, e.g.), and sense (up, down, etc.) is a vector quantity, whereas a scalar quantity involves only magnitude and sense. Force, velocity, and acceleration are vector quantities, while energy, time, and temperature are scalar quantities. A vector can be represented by a straight line, leading to the possibility of constructed graphical solutions in some cases; a situation that will be demonstrated later. Mathematically, a scalar quantity can be represented completely as +50 or -50; while a vector must somehow have its direction represented as well (50 vertical, horizontal, etc.).

## 2.5 PROPERTIES OF FORCES

As stated previously, in order to completely identify a force it is necessary to establish the following:

*Magnitude of the Force:* This is the amount of the force, which is measured in weight units such as pounds or tons.

*Direction of the Force:* This refers to the orientation of its path, called its line of action. Direction is usually described by the angle that the line of action makes with some reference, such as the horizontal.

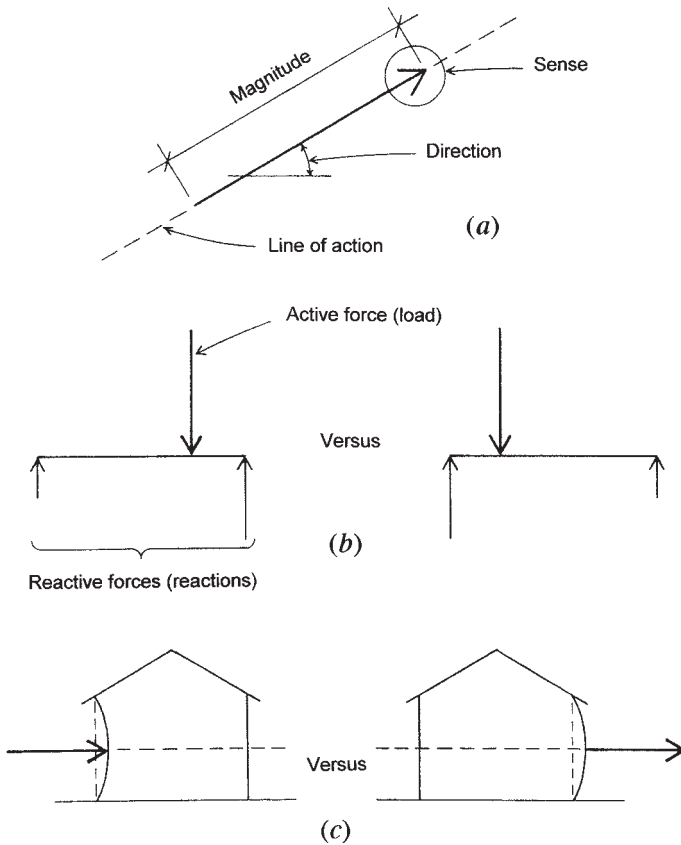
*Sense of the Force:* This refers to the manner in which the force acts along its line of action (up or down, right or left, etc.). Sense is usually expressed algebraically in terms of the sign of the force, either plus or minus.

Forces can be represented graphically in terms of these three properties by the use of an arrow, as shown in Figure 2.3a. Drawn to some scale, the length of the arrow represents the magnitude of the force. The angle of inclination of the arrow represents the direction of the force. The location of the arrowhead represents the sense of the force. This form of representation can be more than merely symbolic, since actual mathematical manipulations may be performed using the vector representation that the force arrows constitute. In the work in this book, arrows are used in a symbolic way for visual reference when performing algebraic computations, and in a truly representative way when performing graphical analyses.

In addition to the basic properties of magnitude, direction, and sense, some other concerns that may be significant for certain investigations are:

*Position of the Line of Action of the Force:* This is considered with respect to the lines of action of other forces or to some object on which the force operates, as shown in Figure 2.3b. For the beam, shifting of the location of the load (active force) effects changes in the forces at the supports (reactions).

*Point of Application of the Force:* Exactly where along its line of action the force is applied may be of concern in analyzing for the specific effect of the force on an object, as shown in Figure 2.3c.



**Figure 2.3** Properties of forces. (a) Graphical representation of a force. (b) Reactive forces. (c) Effect of point of application of a force.

When forces are not resisted, they tend to produce motion. An inherent aspect of static forces is that they exist in a state of *static equilibrium*, that is, with no motion occurring. In order for static equilibrium to exist, it is necessary to have a balanced system of forces. An important consideration in the analysis of static forces is the nature of the geometric arrangement of forces in a given set of forces that constitute a single system. The usual technique for classifying force systems involves consideration of whether the forces in the system are:

**TABLE 2.1 Classification of Force Systems<sup>a</sup>**

System Variation	Qualifications		
	Coplanar	Parallel	Concurrent
1	Yes	Yes	Yes
2	Yes	Yes	No
3	Yes	No	Yes
4	Yes	No	No
5	No <sup>b</sup>	Yes	Yes
6	No	Yes	No
7	No	No	Yes
8	No	No	No

<sup>a</sup>See Figure 2.4.

<sup>b</sup>Not possible—parallel, concurrent forces are automatically coplanar.

*Coplanar:* All acting in a single plane, such as the plane of a vertical wall.

*Parallel:* All having the same direction.

*Concurrent:* All having their lines of action intersect at a common point.

Using these three considerations, the possible variations are given in Table 2.1 and illustrated in Figure 2.4. Note that variation 5 in the table is really not possible, since a set of coaxing forces that is parallel and concurrent cannot be noncoplanar; in fact, the forces all fall on a single line of action and are called collinear.

It is necessary to qualify a set of forces in the manner just illustrated before proceeding with any analysis, whether it is to be performed algebraically or graphically.

## 2.6 MOTION

A force was defined earlier as that which produces or tends to produce motion or a change of motion of bodies. Motion is a change of position with respect to some object regarded as having a fixed position. When the path of a moving point is a straight line, the point has motion of translation. When the path of a point is curved, the point has curvilinear

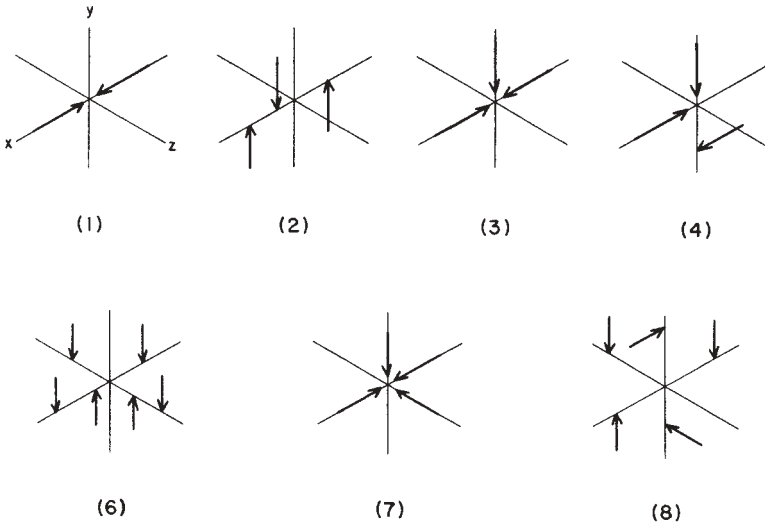


Figure 2.4 Types of force systems.

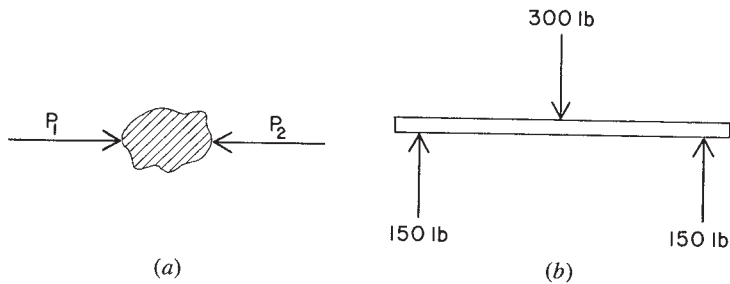
motion or motion of rotation. When the path of a point lies in a plane, the point has plane motion. Other motions are space motions.

Mostly, in the design of structures, a basic goal is to prevent motion. However, for visualization of potential force actions and the actual deformation of force resisting structures, it is very useful to both graphically and mathematically identify the nature of motion implied by the active forces. Ultimately, of course, the desired state for the structure is a final condition described as one of *static equilibrium*, with the external forces balanced by the internal forces, and with no movement, except for small deformations.

## Static Equilibrium

As stated previously, an object is in *equilibrium* when it is either at rest or has uniform motion. When a system of forces acting on an object produces no motion, the system of forces is said to be in *static equilibrium*.

A simple example of equilibrium is illustrated in Figure 2.5a. Two equal, opposite, and parallel forces,  $P_1$  and  $P_2$ , have the same line of action, and act on a body. If the two forces balance each other, the body



**Figure 2.5** Equilibrium of forces.

does not move and the system of forces is in equilibrium. These two forces are *concurrent*. If the lines of action of a system of forces have a point in common, the forces are concurrent.

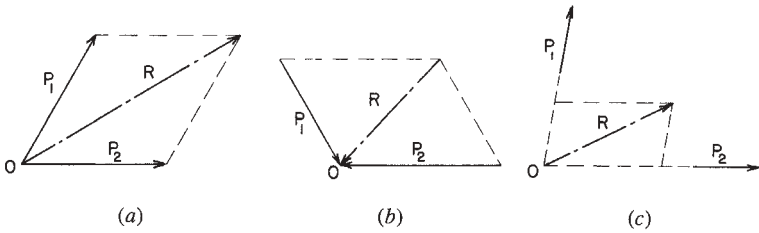
Another example of forces in equilibrium is illustrated in Figure 2.5*b*. A vertical downward force of 300 lb acts at the midpoint in the length of a beam. The two upward vertical forces of 150 lb each (the reactions) act at the ends of the beam. The system of three forces is in equilibrium. The forces are parallel and, not having a point in common, are *nonconcurrent*.

## 2.7 FORCE COMPONENTS AND COMBINATIONS

Individual forces may interact and be combined with other forces in various situations. The net effect of such action produces a singular action that is sometimes required to be observed. Conversely, a single force may have more than one effect on an object, such as a vertical action and a horizontal action simultaneously. This section considers both of these issues: the adding up of single forces (combination) and breaking down of single forces (resolution).

### Resultant of Forces

The *resultant* of a system of forces is the simplest system (usually a single force) that has the same effect as the various forces in the system acting simultaneously. The lines of action of any system of two nonparallel forces must have a point in common, and the resultant of the two forces will pass through this common point. The resultant of two coplanar,



**Figure 2.6** Parallelogram of forces.

nonparallel forces may be found graphically by constructing a *parallelogram of forces*.

This graphical construction is based on the *parallelogram law*, which may be stated thus: two nonparallel forces are laid off at any scale (of so many pounds to the inch) with both forces pointing toward, or both forces pointing away, from the point of intersection of their lines of action. A parallelogram is then constructed with the two forces as adjacent sides. The diagonal of the parallelogram passing through the common point is the resultant in magnitude, direction, and line of action, the direction of the resultant being similar to that of the given forces, toward or away from the point in common. In Figure 2.6a,  $P_1$  and  $P_2$  represent two nonparallel forces whose lines of action intersect at point  $O$ . The parallelogram is drawn, and the diagonal  $R$  is the resultant of the given system. In this illustration, note that the two forces point *away* from the point in common; hence, the resultant also has its direction away from point  $O$ . It is a force upward to the right. Notice that the resultant of forces  $P_1$  and  $P_2$  shown in Figure 2.6b is  $R$ ; its direction is toward the point in common.

Forces may be considered to act at any points on their lines of action. In Figure 2.6c, the lines of action of the two forces  $P_1$  and  $P_2$  are extended until they meet at point  $O$ . At this point, the parallelogram of forces is constructed, and  $R$ , the diagonal, is the resultant of forces  $P_1$  and  $P_2$ . In determining the magnitude of the resultant, the scale used is, of course, the same scale used in laying off the given system of forces.

**Example 1.** A vertical force of 50 lb and a horizontal force of 100 lb, as shown in Figure 2.7a, have an angle of  $90^\circ$  between their lines of action. Determine the resultant.

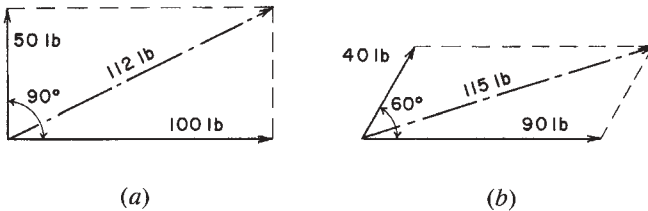


Figure 2.7 Examples 1 and 2.

*Solution:* The two forces are laid off from their point of intersection at a scale of 1 in. = 80 lb. The parallelogram is drawn, and the diagonal is the resultant. Its magnitude scales approximately 112 lb, its direction is upward to the right, and its line of action passes through the point of intersection of the lines of action of the two given forces. By use of a protractor it is found that the angle between the resultant and the force of 100 lb is approximately  $26.5^\circ$ .

**Example 2.** The angle between two forces of 40 and 90 lb, as shown in Figure 2.7*b*, is  $60^\circ$ . Determine the resultant.

*Solution:* The forces are laid off from their point of intersection at a scale of 1 in. = 80 lb. The parallelogram of forces is constructed, and the resultant is found to be a force of approximately 115 lb, its direction is upward to the right, and its line of action passes through the common point of the two given forces. The angle between the resultant and the force of 90 lb is approximately  $17.5^\circ$ .

Attention is called to the fact that these two problems have been solved graphically by the construction of diagrams. Mathematics might have been employed. For many practical problems, graphical solutions give sufficiently accurate answers and frequently require far less time. Do not make diagrams too small. Remember that greater accuracy is obtained by using larger parallelograms of forces.

### Problems 2.7.A–F

By constructing the parallelogram of forces, determine the resultants for the pairs of forces shown in Figures 2.8*a–f*.



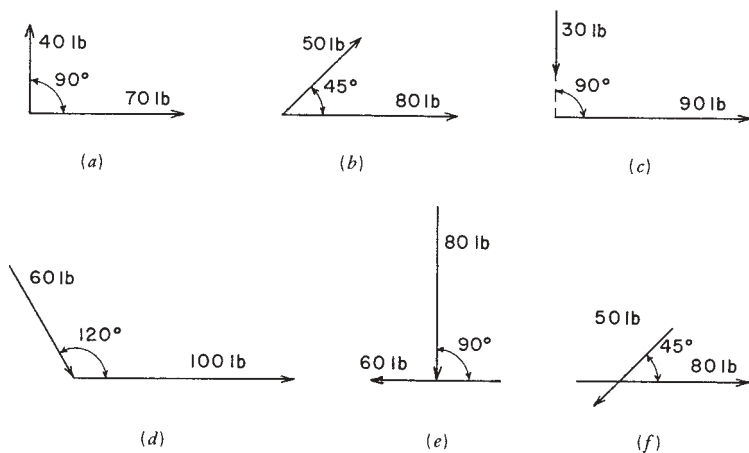


Figure 2.8 Problems 2.8.A–F.

## Components of a Force

In addition to combining forces to obtain their resultant, it is often necessary to replace a single force by its *components*. The components of a force are the two or more forces that, acting together, have the same effect as the given force. In Figure 2.7a, if we are *given* the force of 112 lb, its vertical component is 50 lb and its horizontal component is 100 lb. That is, the 112-lb force has been *resolved* into its vertical and horizontal components. Any force may be considered as the resultant of its components.

## Combined Resultants

The resultant of more than two nonparallel forces may be obtained by finding the resultants of pairs of forces and finally the resultant of the resultants.

**Example 3.** Let it be required to find the resultant of the concurrent forces  $P_1$ ,  $P_2$ ,  $P_3$ , and  $P_4$ , shown in Figure 2.9.

**Solution:** By constructing a parallelogram of forces, the resultant of  $P_1$  and  $P_2$  is found to be  $R_1$ . Similarly, the resultant of  $P_3$  and  $P_4$  is  $R_2$ . Finally, the resultant of  $R_1$  and  $R_2$  is  $R$ , the resultant of the four given forces.

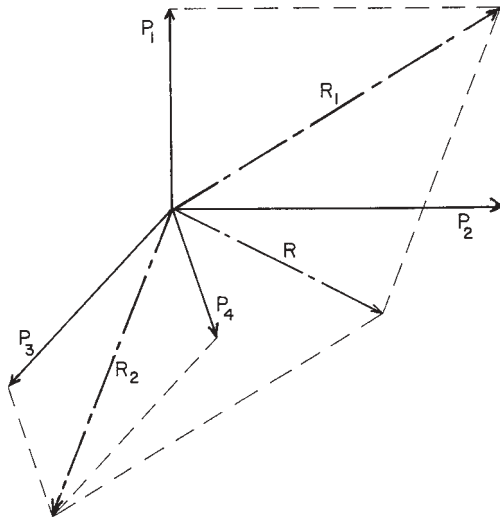


Figure 2.9 Finding a resultant by pairs.

**Problems 2.7.G–I**

Using graphical methods, find the resultants of the systems of concurrent forces shown in Figures 2.10(g)–(i).

**Equilibrant**

The force required to maintain a system of forces in equilibrium is called the *equilibrant* of the system. Suppose that we are required to investigate

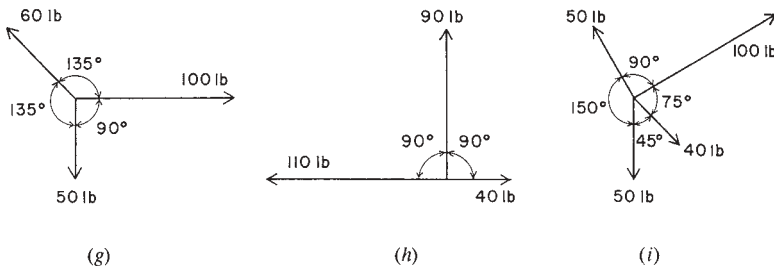
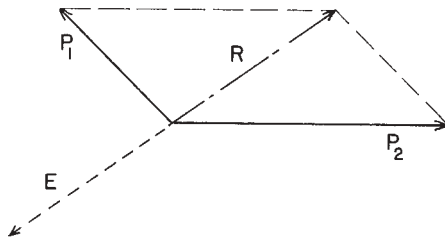


Figure 2.10 Problems 2.7.G–I.



**Figure 2.11** Resultant and equilibrant.

the system of two forces,  $P_1$  and  $P_2$ , as shown in Figure 2.11. The parallelogram of forces is constructed, and the resultant is found to be  $R$ . The system is not in equilibrium. The force required to maintain equilibrium is force  $E$ , shown by the dotted line.  $E$ , the equilibrant, is the same as the resultant in magnitude and direction, but is opposite in sense. The three forces,  $P_1$ ,  $P_2$ , and  $E$ , constitute a system in equilibrium.

If two forces are in equilibrium, they must be equal in magnitude, opposite in sense, and have the same direction and line of action. Either of the two forces may be said to be the equilibrant of the other. The resultant of a system of forces in equilibrium is zero.

## 2.8 GRAPHICAL ANALYSIS OF FORCES

### Force Polygon

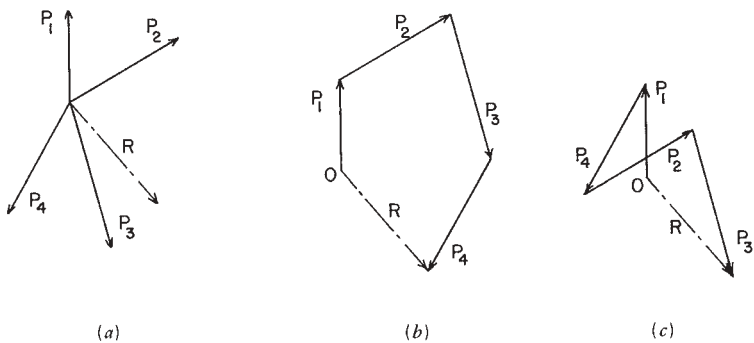
The resultant of a system of concurrent forces may be found by constructing a *force polygon*. To draw the force polygon, begin with a point and lay off, at a convenient scale, a line parallel to one of the forces, with its length equal to the force in magnitude, and having the same sense. From the termination of this line, draw similarly another line corresponding to one of the remaining forces and continue in the same manner until all the forces in the given system are accounted for. If the polygon does not close, the system of forces is not in equilibrium, and the line required to close the polygon *drawn from the starting point* is the resultant in magnitude and direction. If the forces in the given system are concurrent, the line of action of the resultant passes through the point they have in common.

If the force polygon for a system of concurrent forces closes, the system is in equilibrium, and the resultant is zero.

**Example 4.** Let it be required to find the resultant of the four concurrent forces  $P_1$ ,  $P_2$ ,  $P_3$ , and  $P_4$  shown in Figure 2.12a. This diagram is called the *space diagram*; it shows the relative positions of the forces in a given system.

**Solution:** Beginning with some point such as  $O$ , shown in Figure 2.12b, draw the upward force  $P_1$ . At the upper extremity of the line representing  $P_1$ , draw  $P_2$ , continuing in a like manner with  $P_3$  and  $P_4$ . The polygon does not close; therefore the system is not in equilibrium. The resultant  $R$ , shown by the dot-and-dash line, is the resultant of the given system. Note that its direction is *from* the starting point  $O$ , downward to the right. The line of action of the resultant of the given system shown in Figure 2.12a has its line of action passing through the point they have in common, its magnitude and direction having been found in the force polygon.

In drawing the force polygon, the forces may be taken in any sequence. In Figure 2.12c, a different sequence is taken, but the resultant  $R$  is found to have the same magnitude and direction as previously found in Figure 2.12b.



**Figure 2.12** Force polygon for a set of concurrent forces.

### Bow's Notation

Thus far, forces have been identified by the symbols  $P_1, P_2,$  and so on. A system of identifying forces, known as Bow's notation, affords many advantages. In this system, letters are placed in the space diagram on each side of a force, and a force is identified by two letters. The sequence in which the letters are read is important. Figure 2.13a shows the space diagram of five concurrent forces. Reading about the point in common *in a clockwise manner*, the forces are  $AB, BC, CD, DE,$  and  $EA$ . When a force in the force polygon is represented by a line, a letter is placed at each end of the line. As an example, the vertical upward force in Figure 2.13a is read  $AB$  (note that this is read clockwise about the common point); in the force polygon (Figure 2.13b), the letter  $a$  is placed at the bottom of the line representing the force  $AB$  and the letter  $b$  is at the top. Use capital letters to identify the forces in the space diagrams and lowercase letters in the force polygon. From point  $b$  in the force polygon, draw force  $bc$ , then  $cd$ , and continue with  $de$  and  $ea$ . Since the force polygon closes, the five concurrent forces are in equilibrium.

In reading forces, a clockwise manner is used in all the following discussions. It is important that this method of identifying forces be thoroughly understood. To make this clear, suppose that a force polygon is drawn for the five forces shown in Figure 2.13a, reading the forces in sequence in a counterclockwise manner. This will produce the force polygon shown in Figure 2.13c. Either method may be used, but for consistency the method of reading clockwise is used here.

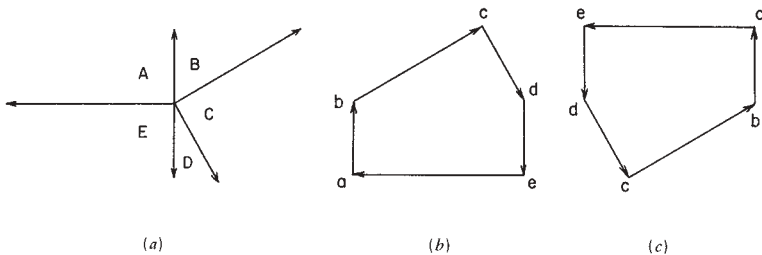


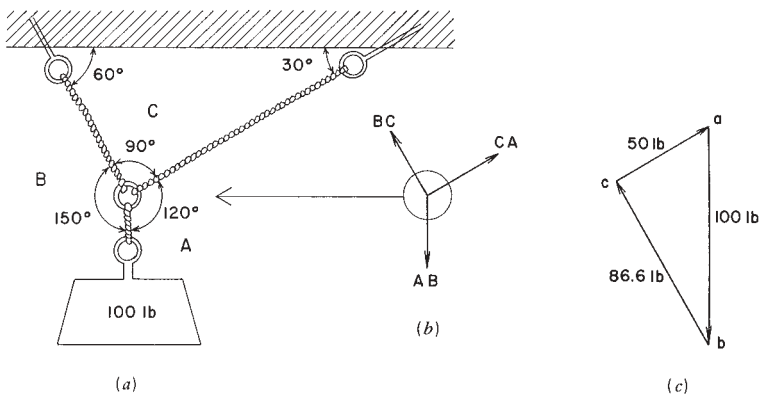
Figure 2.13 Use of Bow's notation.

### Use of the Force Polygon

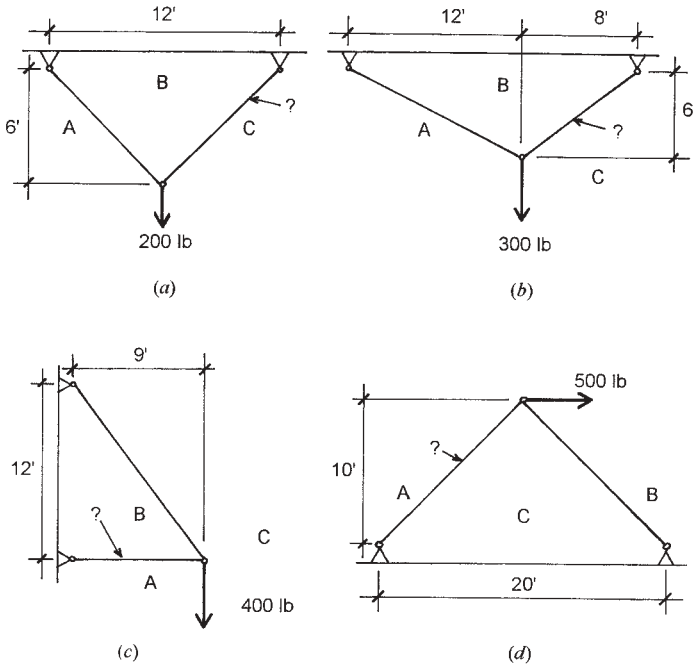
Two ropes are attached to a ceiling and their lower ends are connected to a ring, making the arrangement shown in Figure 2.14*a*. A weight of 100 lb is suspended from the ring. Obviously, the force in the rope *AB* is 100 lb, but the magnitudes of the forces in ropes *BC* and *CA* are unknown.

The forces in the ropes *AB*, *BC*, and *CA* constitute a concurrent force system in equilibrium. The magnitude of only one of the forces is known—it is 100 lb in rope *AB*. Since the three concurrent forces are in equilibrium, their force polygon must close, and this fact makes it possible to find the magnitudes of the *BC* and *CA*. Now, at a convenient scale, draw the line *ab* (Figure 2.14*c*) representing the downward force *AB*, 100 lb. The line *ab* is one side of the force polygon. From point *b*, draw a line parallel to rope *BC*; point *c* will be at some location on this line. Next, draw a line through point *a* parallel to rope *CA*; point *c* will be at some position on this line. Since point *c* is also on the line through *b* parallel to *BC*, the intersection of the two lines determines point *c*. The force polygon for the three forces is now completed; it is *abc*, and the lengths of the sides of the polygon represent the magnitudes of the forces in ropes *BC* and *CA*, 86.6 lb and 50 lb, respectively.

Particular attention is called to the fact that the lengths of the ropes in Figure 2.14*a* are not an indication of magnitude of the forces within the ropes; the magnitudes are determined by the lengths of the correspond-



**Figure 2.14** Solution of a problem with concurrent forces.



**Figure 2.15** Problems 2.8.A–D.

ing sides of the force polygon (Figure 2.14c). Figure 2.14a merely determines the geometric layout for the structure.

**Problems 2.8.A–D**

Find the sense (tension or compression) and magnitude of the internal forces in the members indicated by question marks in Figures 2.15a–d, using graphical methods.

**2.9 INVESTIGATION OF FORCE ACTIONS**

A convenient way to determine the unknown forces acting on a body, or the unknown internal forces in a structure, is to construct a free-body diagram. This may be for a whole structure or a part of a structure. The

usual procedure is to imagine the defined element (body) to be cut away from adjoining parts and moved to a free position in space. See the discussion in Section 1.10.

### Graphical Solution of Forces

Consider Figure 2.16*a*, which represents two members framing into a wall, the upper member being horizontal and the angle between the members being  $30^\circ$ . A weight of 200 lb is placed at the point where the members meet. Figure 2.16*b* is a diagram showing the block as a free body with the forces acting on it consisting of its own weight and the two unknown internal forces in the members. This concurrent force system is represented in Figure 2.16*c*, with letters placed on the figure to utilize Bow's notation. Thus, the forces acting on the body are *AB* (the force due to gravity), and the unknowns *BC* and *CA*. The arrows placed on the unknown forces, indicating their sense, would seem to be evident, although they have not actually been determined at this point.

To determine the unknown internal forces in the frame members, a force polygon of this concurrent set of forces may be constructed. Start by drawing the vector *ab* downward to a convenient scale measured at 200, as shown in Figure 2.16*d*. On this diagram, through point *a*, draw a

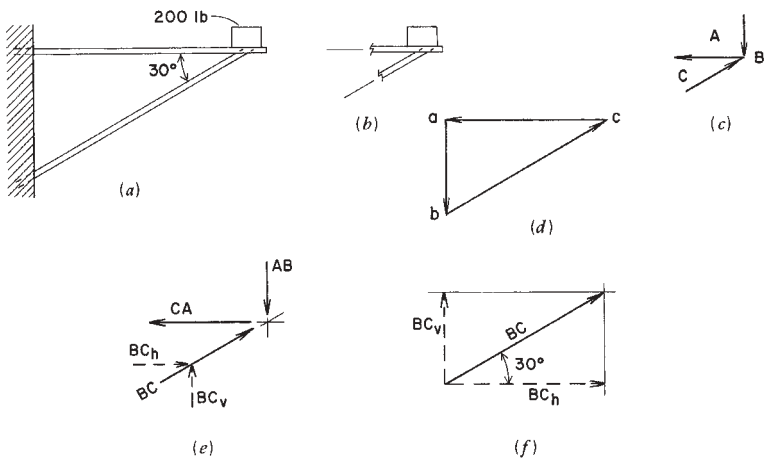


Figure 2.16 Use of the free-body diagram.



horizontal line representing force  $ca$ . Then, through point  $b$ , draw a line at  $30^\circ$  representing the force  $bc$ . The intersection of these two lines locates the point  $c$  on the diagram and completes the force polygon. By using the scale that was used to lay out force  $ab$ , the lengths of the other two sides of the polygon can be measured; these are the magnitudes of the unknown forces. Accuracy in this case will depend on how large a figure is drawn and how carefully it is constructed. The sense of the forces can be determined by following the sequence of force flow on the polygon: from  $a$  to  $b$  to  $c$  to  $a$ . Thus, the assumed senses are shown to be correct.

### Algebraic Solution

The preceding problem obviously also lends itself to a mathematical solution. Consider the free-body diagram of the forces as shown in Figure 2.16*e*. On this figure, the force  $BC$  is shown both as a single force and as a combination of its horizontal and vertical components; either representation can be used for this force. The relationship of force  $BC$  to its components is shown in Figure 2.16*f*. The purpose for consideration of the components of  $BC$  is demonstrated in the following work.

The forces in the free-body diagram in this example are constituted as a concentric, coplanar force system (see Section 2.5). For such a system, the algebraic conditions for static equilibrium may be stated as follows:

$$\Sigma F_H = 0 \quad \text{and} \quad \Sigma F_V = 0$$

That is to say, the summation of the horizontal force components of all the forces is zero, and the summation of the vertical components of all the forces is zero. Referring to Figure 2.16*e*, and applying these conditions to the example,

$$\begin{aligned}\Sigma F_H = 0 &= CA + BC_H \\ \Sigma F_V = 0 &= AB + BC_V\end{aligned}$$

To implement these algebraically, a sign convention must be assumed. Assume the following:

For vertical forces, + is up, - is down.

For horizontal forces: + is to the right, - is to the left.

Thus, from the summation of the vertical forces, using the known value of  $AB$ ,

$$\Sigma F_V = 0 = (-200) + BC_V$$

from which

$$BC_V = +200, \quad \text{or} \quad 200 \text{ lb up}$$

If this component is up, then the force  $BC$ , as indicated in Figure 2.16, is correctly shown as a compression force. To obtain the value for  $BC$ , consider the relation of the force to its components, as shown in Figure 2.16f. Thus,

$$BC = \frac{BC_V}{\sin 30^\circ} = \frac{200}{0.5} = 400 \text{ lb}$$

Then, using the summation of horizontal forces,

$$\Sigma F_H = 0 = CA + BC_H = CA + (+400 \times \cos 30^\circ)$$

from which  $CA$  is obtained as  $-346$  lb; the minus sign indicates the correctness of the assumption shown in Figure 2.16e: namely, that  $CA$  is in tension.

## Two-Force Members

When a member in equilibrium is acted on by forces at only two points, it is known as a two-force member. The resultant of all the forces at one point must be equal, opposite in sense, and have the same direction and line of action as the resultant of the forces at the other point. The internal force in a linear two-force member is either tension or compression.

In Figure 2.16a, each of the two members in the frame is a two-force member. A free-body diagram of either member will show only one force at an end, equal and opposite in sense to the force at the other end. The members of planar trusses are assumed to be of this form, so that the analysis of the truss may be achieved by a solution of the concentric forces at the joints of the truss. This is demonstrated in Chapter 3.

## 2.10 FRICTION

Friction is a force of resistance to movement that is developed at the contact face between objects when the objects are made to slide with respect to each other. For the object shown in Figure 2.17*a*, being acted on by its own weight and the inclined force  $F$ , the impending motion is that of the block toward the right along the supporting surface. The force tending to cause the motion is the horizontal component of  $F$ , that is, the component parallel to the sliding surface. The vertical component of  $F$  combines with the weight of the block  $W$  to produce a force pressing the block against the plane. This pressure-generating force, called the normal force, is what produces friction.

A free-body diagram of the forces is shown in Figure 2.17*b*. For equilibrium of the block, two components of resistance must be developed. For equilibrium in a direction normal to the plane of friction (vertical here), the reactive force  $N$  is required, being equal and opposite in sense to the normal force on the plane. For equilibrium in a direction parallel to the plane (horizontal here), a frictional resistance  $F'$  must be developed that is at least as great as the force tending to cause sliding. For this situation there are three possibilities, as follows:

1. The block does not move because the potential friction resistance is greater than the impelling force, that is,

$$F' \text{ is greater than } F \cos \Theta$$

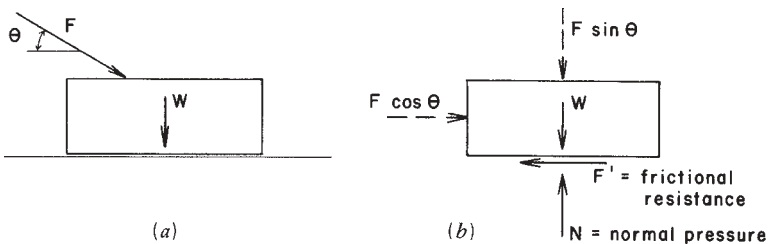


Figure 2.17 Development of sliding friction.

- The block moves because the friction is not of sufficient magnitude, that is,

$$F' \text{ is less than } F \cos \Theta$$

- The block is in equilibrium, but just on the verge of moving because the potential friction force is exactly equal to the force tending to induce sliding, that is,

$$F' = F \cos \Theta$$

From observations and experimentation, the following deductions have been made about friction.

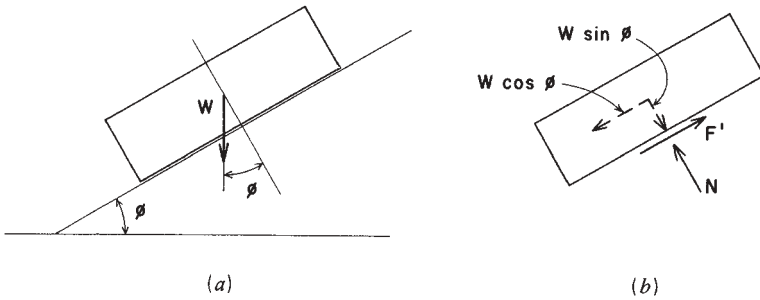
- The friction-resisting force ( $F'$  in Figure 2.17) always acts in a direction to oppose motion; that is, it acts opposite to the slide-inducing force.
- For dry, smooth surfaces, the frictional resistance developed up to the moment of sliding is directly proportional to the normal pressure between the surfaces. This limiting value for the force is expressed as

$$F' = \mu N$$

in which  $\mu$  (Greek lowercase mu) is called the coefficient of friction.

- The frictional resistance is independent of the amount of contact area.
- The coefficient of static friction (before motion occurs) is greater than the coefficient of kinetic friction (during actual sliding). That is, for the same amount of normal pressure, the frictional resistance is reduced once motion actually occurs.

Frictional resistance is ordinarily expressed in terms of its maximum potential value. Coefficients for static friction are determined by finding the ratio between the slide-inducing force and the normal force that creates pressure just at the point of sliding. A simple experiment consists of placing a block on an inclined surface and steadily increasing the angle



**Figure 2.18** Derivation of the coefficient of friction.

of inclination until sliding occurs (see Figure 2.18*a*). Referring to the free-body diagram of the block in Figure 2.18*b*, we note

$$F' = \mu N = W \sin \phi$$

$$N = W \cos \phi$$

and, as previously noted, the coefficient of friction is expressed as the ratio of  $F'$  to  $N$ , or

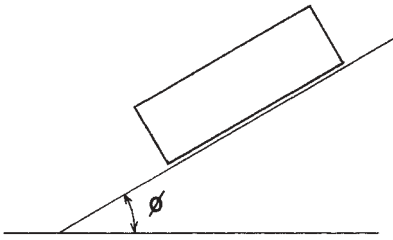
$$\mu = \frac{F'}{N} = \frac{W \sin \phi}{W \cos \phi} = \tan \phi$$

Approximate values for the coefficient of static friction for various combinations of objects in contact are given in Table 2.2.

Problems involving friction are usually one of two types. The first involves situations in which friction is one of the forces in a system, and the problem is to determine whether the frictional resistance is sufficient to maintain the equilibrium of the system. For this type of problem, the

**TABLE 2.2** Range of Values for Coefficient of Static Friction

Contact Surfaces	Coefficient $\mu$
Wood on wood	0.40–0.70
Metal on wood	0.20–0.65
Metal on metal	0.15–0.30
Metal on stone, masonry, concrete	0.30–0.70



**Figure 2.19** Use of the inclined plane to determine the coefficient of static friction.

solution consists of writing the equations for equilibrium, including the maximum potential friction, and interpreting the results. If the frictional resistance is not large enough, sliding will occur; if it is just large enough or excessive, sliding will not occur.

The second type of problem involves situations in which the force required to overcome friction must be found. In this case, the slide-inducing force is simply equated to the maximum potential friction resistance, and the required force is determined.

**Example 5.** A block is placed on an inclined plane whose angle is slowly increased until sliding occurs (see Figure 2.19). If the angle of the plane with the horizontal is  $35^\circ$  when sliding begins, what is the coefficient for sliding friction between the block and the plane?

*Solution:* As previously derived, the coefficient of friction may be stated as the tangent of the angle of inclination of the plane; thus,

$$\mu = \tan \phi = \tan 35^\circ = 0.70$$

**Example 6.** Find the horizontal force  $P$  required to slide a block weighing 100 lb if the coefficient of static friction is 0.30 (see Figure 2.20).

*Solution:* For sliding to occur, the slide-inducing force  $P$  must be slightly larger than the frictional resistance  $F'$ . Thus,

$$P = F' = \mu N = 0.30(100) = 30 \text{ lb}$$

The force must be slightly larger than 30 lb.

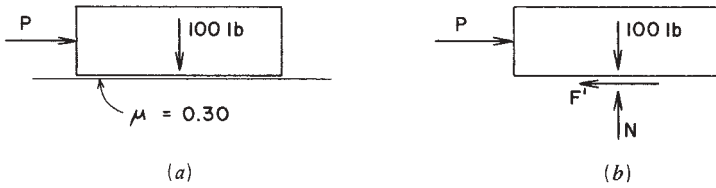


Figure 2.20 Example 6.

**Example 7.** A block is pressed against a vertical wall with a 20-lb force that acts upward at an angle of  $30^\circ$  with the horizontal (see Figure 2.21a).

- (a) Express the frictional resistance to motion in terms of the available pressure.
- (b) If the block weighs 15 lb and the coefficient of static friction is 0.40, will the block slide?

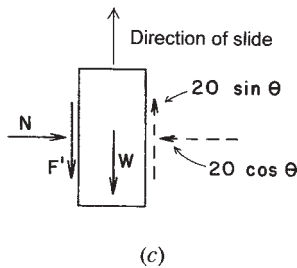
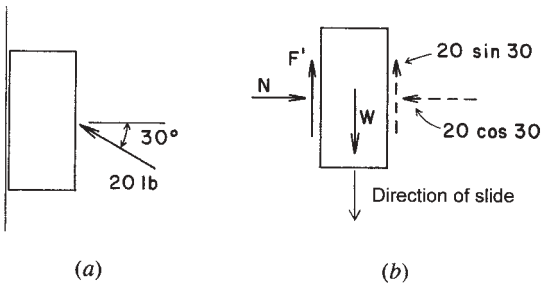


Figure 2.21 Example 7.

- (c) At what angle must the 20-lb force act to cause the 15-lb block to slide upward, if the coefficient of static friction is 0.40?

*Solution:* For (a),

$$F' = \mu N = \mu(20 \cos 30^\circ) = 17.32\mu \text{ lb}$$

For (b), the sliding resistance must equal the net slide-inducing force, or

$$\text{required } F' = [W - (20 \sin 30^\circ)] = W - 10 = 15 - 10 = 5 \text{ lb}$$

From (a), the available resistance is

$$F' = 17.32(0.40) = 6.93 \text{ lb}$$

Therefore, the block will not slide.

For (c),

$$F' = (20 \sin \phi) - 15$$

or

$$0.40(20 \cos \phi) = (20 \sin \phi) - 15$$

from which  $\phi = 81.1^\circ$ .

***Problem 2.10.A***

Find the angle at which the block shown in Figure 2.18 will slip if the coefficient of static friction is 0.35.

***Problem 2.10.B***

For the block shown in Figure 2.22, find the value of  $P$  required to keep the block from slipping if  $\phi = 10^\circ$  and  $W = 10 \text{ lb}$ .

***Problem 2.10.C***

For the block shown in Figure 2.22, find the weight for the block that will result in slipping if  $\phi = 15^\circ$  and  $P = 10 \text{ lb}$ .



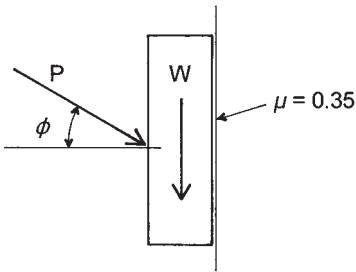


Figure 2.22 Problems 2.10.B, C.

## 2.11 MOMENTS

The term *moment* is commonly used to designate the tendency of a force to cause rotation about a given point or axis. The unit of measurement for moments is a compound produced by the multiplication of the force (in pounds, tons, etc.) times a distance (in feet, inches, etc.). A moment is thus said to consist of so many ft-lb, kip-in., and so on. The point or axis about which rotation is induced is called the center of moments. The perpendicular distance between the line of action of the force and the center of moments is called the lever arm or moment arm. Thus, a moment has a magnitude that is determined as

$$\text{moment} = (\text{magnitude of force}) \times (\text{length of moment arm})$$

Consider the horizontal force of 100 lb shown in Figure 2.23. If point A is the center of moments, the lever arm of the force is 5 ft. Then the moment of the 100-lb force with respect to point A is  $100 \times 5 = 500$

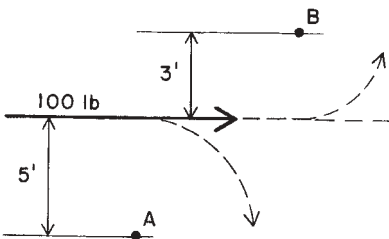


Figure 2.23 Moment of a force about a point.

ft-lb. In this illustration, the force tends to cause a clockwise rotation about point *A*, which is the sense, or sign, of the moment. Ordinarily, clockwise rotation is considered to be positive and counterclockwise moment to be negative. Thus, the complete designation of the moment is +500 ft-lb.

In Figure 2.23, the 100-lb force has a moment arm of 3 ft with respect to point *B*. With respect to point *B*, the force has a counterclockwise moment, determined to be  $100 \times 3 = -300$  ft-lb.

### Increasing Moments

A moment may be increased by increasing the magnitude of the force or by increasing the distance of the moment arm. For the wrench in Figure 2.24, the limit for rotational effort in terms of moment on the bolt head is limited by the effective wrench length and the force exerted on the handle. Additional twisting moment on the bolt can be developed by increasing the force. However, for a limited force, the wrench length might be extended by slipping a pipe over the wrench handle, thus producing a larger moment with the same force.

If a given moment is required, various combinations of force and moment arm may be used to produce the moment. For example, if the combination of the given force of 50 lb was found to be just sufficient to twist the nut in Figure 2.24 with the pipe over the wrench handle, what force would have been required if the pipe was not used? With the pipe, the moment is  $50 \times 25 = 1250$  in.-lb. If the pipe is not used, the required force is thus found as  $1250 / 10 = 125$  lb.

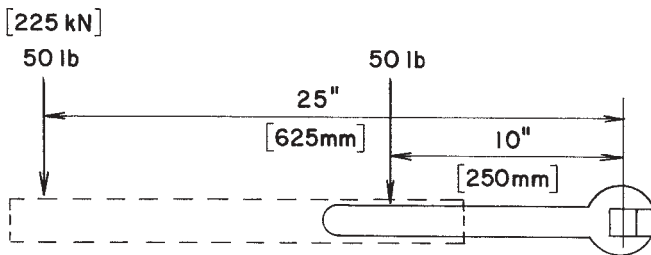


Figure 2.24 Effect of change in the moment arm.

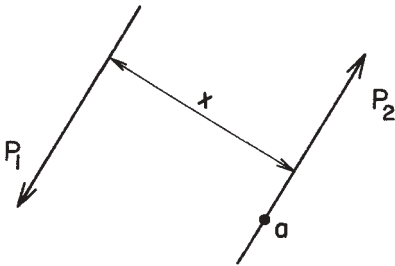


Figure 2.25 A mechanical couple.

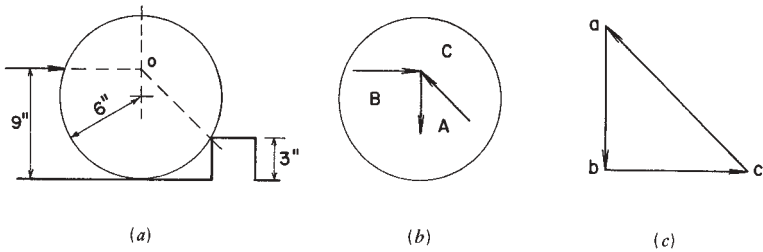
### Moment of a Mechanical Couple

A mechanical couple is a means for visualization of a pure rotational effect. As produced by a couple, it takes a form as shown in Figure 2.25, with two parallel forces (the couple) acting in opposite directions at some distance apart. If the two forces are equal in magnitude, the resultant of the forces is zero as a force magnitude. However, the resultant effect of the forces produces a moment, which is the true resultant of the force system: a mechanical couple. The magnitude of the moment is simply the product of one of the forces times the distance between the separated lines of action of the parallel forces. In the illustration, the sense of the moment is counterclockwise.

An example of a mechanical couple is that produced when a person uses two hands to turn a steering wheel. The result of this push-pull effort is neither a net push or a net pull on the wheel, but rather a pure rotation of the steering column. This is directly analogous to the development of internal bending resistance in structural members, where opposed tension and compressive stresses produce pure rotational effort. This phenomenon is discussed for beams in Chapter 11.

### Force Required to Produce Motion

Figure 2.26a shows a wheel under the action of a horizontal force that is attempting to roll the wheel over a fixed block. In order to produce motion, the force must be slightly greater than that required for equilibrium. Pushing on the wheel produces a set of forces consisting of the weight of the wheel, the pushing force, and the force of the corner of the fixed block that pushes back on the wheel. The combination of these three



**Figure 2.26** Force required to produce motion; graphical solution.

forces is shown in the free-body diagram of the wheel in Figure 2.26*b*. They constitute a concentric force system for which a force polygon is shown in Figure 2.26*c*.

If the wheel weighs 400 lb and the vector for this force is drawn to a scale in proportion to the 400-lb magnitude (*ca* on the force polygon), the force required for equilibrium may be found by measuring the vector *bc* on the polygon. A graphic solution that begins with the scaled layout of the wheel, the block, and the pushing force (Figure 2.26*a*) to determine the angle of force *CA*, will determine that the pushing force at the point of motion must exceed a value of approximately 330 lb. An algebraic solution can also be performed, for example, a summation of moments about the contact point between the wheel and the fixed block.

**Example 8.** Figure 2.27*a* shows a masonry pier that weighs 10,000 lb. Determine the magnitude of the horizontal force applied at the upper left corner that will be required to overturn the pier.

**Solution:** Tipping of the pier will occur with rotation about the lower right corner of the pier. The forces on the pier at the point of tipping will consist of the pier weight, the horizontal push at the top, and the force exerted by the ground at the bottom right corner. A free-body diagram of the pier under the action of these three forces is shown in Figure 2.27*b*. Figure 2.27*c* shows a force polygon for these forces that includes a magnitude for the pushing force at the moment of the beginning of tipping. A slight increase in the tipping force above this value will produce tipping (more often described as *overturning* in engineering).

As with the wheel in the preceding illustration, a scaled layout may be used to determine the magnitude of the pushing force. However, a sim-

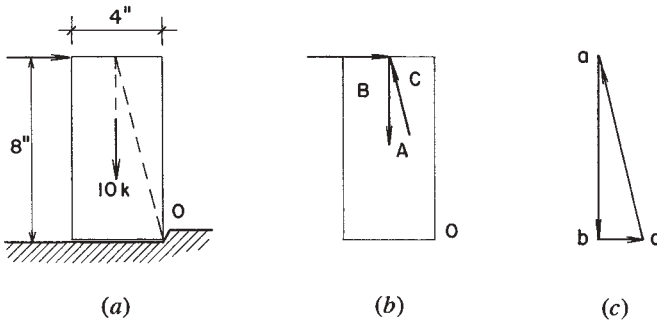


Figure 2.27 Example 8.

ple algebraic solution may be performed using a summation of moments about the lower right corner (point  $O$  in Figure 2.27b). As the line of action of the force at this point has no moment in this summation, the equation for moments is reduced to that involving only the pushing force and the weight of the pier. Thus,

$$\Sigma M_o = +(BC \times 8) - (AB \times 2)$$

Entering the known value of 10,000 lb for  $AB$  in this equation will produce an answer of 2500 lb for the pushing force. Any force exceeding 2500 lb will tend to tip the pier.

**Problem 2.11.A**

Using a graphical solution, find the horizontal force  $P$  required to roll the cylinder in Figure 2.28a over the fixed block. The cylinder is 20 in. in diameter and weighs 500 lb.

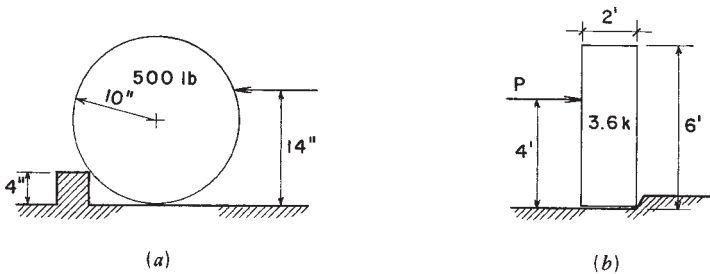


Figure 2.28 Problems 2.11.A–C.

**Problem 2.11.B**

The masonry pier in Figure 2.28*b* weighs 3600 lb. If the force  $P$  as shown is 800 lb, will the pier tip about its lower right corner?

**Problem 2.11.C**

If the pier in Figure 2.11*b* weighs 5000 lb, find the magnitude required for force  $P$  to cause overturning.

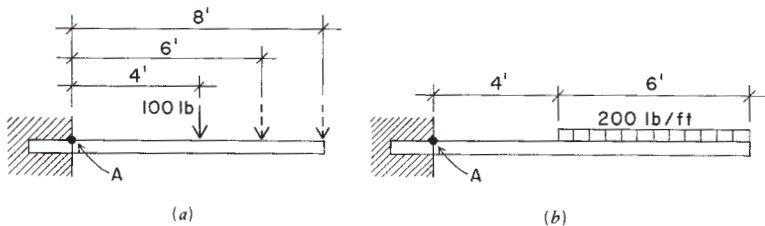
**2.12 FORCES ON A BEAM**

Figure 2.29*a* shows a cantilever beam with a single concentrated load of 100 lb placed 4 ft from the face of the supporting wall. In this position, the moment of the force about point  $A$  (the face of the support) is  $100 \times 4 = 400$  ft-lb. If the load is moved 2 ft farther to the right, the moment about point  $A$  is 600 ft-lb. When the load is moved to the end of the beam, the moment at point  $A$  is 800 ft-lb.

Figure 2.29*b* shows a cantilever beam with a uniformly distributed load over part of its length. For finding moments due to distributed loads, a procedure commonly used is to find the total of the distributed load and to consider it to be a single concentrated load placed at the center of the distributed load. In this case, the total load is  $200 \times 6 = 1200$  lb, and its effective location is at a point 3 ft from the end of the beam. Thus, the moment of the load about point  $A$  is  $1200 \times 7 = 8400$  ft-lb.

**Equilibrium of Coplanar Forces**

For a general coplanar force system, equilibrium can be established with the satisfying of three equations, as follows:



**Figure 2.29** Forces on cantilever beams.

1. The algebraic sum of the horizontal forces is zero.
2. The algebraic sum of the vertical forces is zero.
3. The algebraic sum of the moments of all the forces about any point in the plane is zero.

These summations can be made for any coplanar system of forces. However, any additional qualifications of the forces may result in simplification of the algebraic conditions. For example, when the forces are *concurrent* (all meeting at a single point), they have no moments with respect to each other and the condition for equilibrium of moments can be eliminated, leaving only the two force equations. This was the case for the system shown in Figure 2.26. An even simpler qualification is that of *colinear* forces, all acting on a single line of action, such as the system shown in Figure 2.30*a*. Such a system, if in equilibrium, consists of two equal forces of opposite sense.

Beams are generally operated on by parallel, coplanar forces. This eliminates one of the force summations from the condition for general coplanar systems, since all the forces are in a single direction. There are thus only two equations of equilibrium necessary for the parallel system, and consequently only two available for solution of the system. Eliminating one force equation from the general set leaves

1. The sum of the vertical forces equals zero.
2. The sum of the moments about any point equals zero.

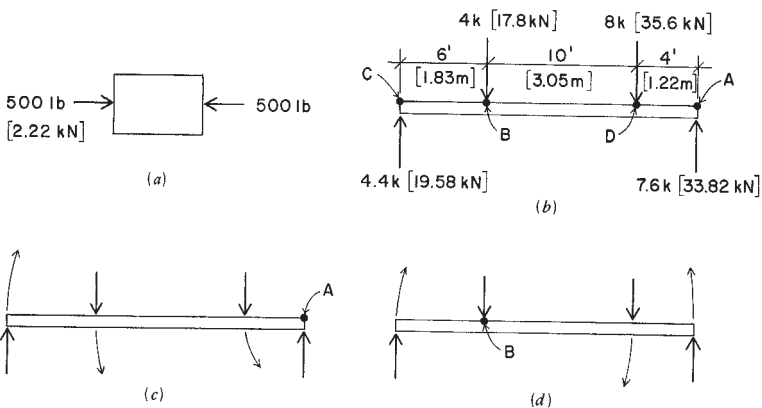


Figure 2.30 Moment effects on a beam.

However, another possibility for establishing equilibrium is to satisfy the condition that the sum of the moments of the forces about two separate points is zero. Thus, another set of equations that may be used for the beam is

1. The sum of the moments about point  $A$  is zero.
  2. The sum of the moments about point  $B$  is zero
- Where:* point  $A$  is a different point in the plane than point  $B$ .

Consider the simple beam in Figure 2.30*b*. Four vertical forces act on this beam and are in equilibrium. The two downward forces, or loads, are 4 kips and 8 kips. Opposing these are the support reaction forces at the ends of the beam, 4.4 kips and 7.6 kips. If these parallel forces are indeed in equilibrium, they should satisfy the equilibrium equations for a parallel system. Thus,

$$\Sigma F_v = 0 = +4.4 - 4 - 8 + 7.6 = (+12) + (-12)$$

and the forces are in balance.

$$\Sigma M_A = 0 = +(4.4 \times 20) - (4 \times 14) - (8 \times 4) = (+88) + (-88)$$

and the sum of the moments about point  $A$  is indeed zero.

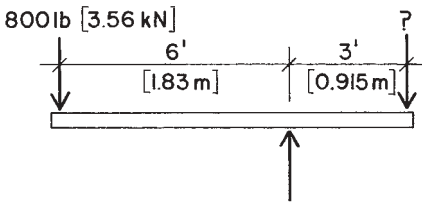
To further demonstrate the equilibrium of the force values, moments may be taken about any other point in the plane. For example, for point  $B$ , which is the location of the 4-kip load,

$$\Sigma M_B = +(4.4 \times 6) + (8 \times 10) - (7.6 \times 14) = +(106.4) - (106.4)$$

which verifies the balance of moments about point  $B$ .

Another type of problem involves the finding of some unknown forces in a parallel system. Remember that the two conditions of equilibrium for the parallel system provide two algebraic equations, which potentially may be used to find two unknown forces in the system. Consider the beam shown in Figure 2.31, with a single support and a load of 800 lb at one end. The problem is to determine the required value for a load at the other end of the beam that will maintain equilibrium and the value for the single support reaction. A summation of vertical forces will produce an equation with two unknowns. Indeed, the two unknown





**Figure 2.31** Beam with a single support.

forces could be solved using two equations in two unknowns. However, a simpler procedure frequently used is to write equations involving only one unknown in a single equation at a time, if possible. For example, an equation for the sum of moments about either the right end or the support will produce such an equation. Thus, for moments about the support, calling the unknown load  $x$ ,

$$\Sigma M = 0 = -(800 \times 6) + (x \times 3); \quad \text{thus, } x = 1600 \text{ lb}$$

Then, from a summation of vertical forces, calling the reaction force  $R$ ,

$$\Sigma F = 0 = -800 + R - 1600; \quad \text{thus, } R = 2400 \text{ lb}$$

This form of solution is frequently used to find reactions for ordinary beams with two supports, which is discussed next.

### **Problem 2.12.A**

Write the two equations for moments for the four forces in Figure 2.30*b*, taking points  $C$  and  $D$  as the centers of moments, to verify the equilibrium of the system.

## **Determination of Reactions for Beams**

As noted earlier, *reactions* are the forces at the supports of beams that hold the loads in equilibrium. A single-span beam is shown in Figure 2.32, with two supports, one at each end of the beam. As these supports are not shown to have resistance to rotation (called *fixed supports*), they are assumed to be resistant only to the necessary vertical forces, and described as *simple supports*. This common beam, with a single span and

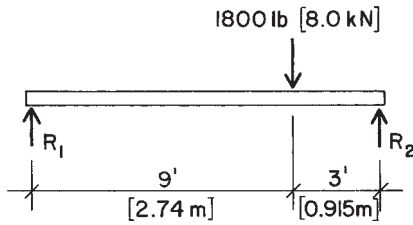


Figure 2.32 Example 9.

two simple supports, is referred to as a *simple beam*. The computations that follow will demonstrate the common procedure for finding the values for the magnitudes of the two support reactions for a simple beam. Note that the two reactions in Figure 2.32 are designated  $R_1$  and  $R_2$ , for the left and right reactions, respectively. This is a common practice that is followed throughout the work in this book.

**Example 9.** Compute the reactions for the beam in Figure 2.32.

*Solution:* Taking the right reaction as the center of moments,

$$\Sigma M = 0 = +(R_1 \times 12) - (1800 \times 3); \quad \text{thus, } R_1 = \frac{5400}{12} = 450 \text{ lb}$$

Taking the left reaction as the center of moments,

$$\Sigma M = 0 = +(1800 \times 9) - (R_2 \times 12); \quad \text{thus, } R_2 = \frac{16,200}{12} = 1350 \text{ lb}$$

To see whether a mistake has been made, the three forces (load and two reactions) may be checked for equilibrium of the vertical forces; thus,

$$\Sigma F = 0 = +450 - 1800 + 1350,$$

and the net force is indeed zero.

**Example 10.** Compute the reactions for the simple beam in Figure 2.33 with three concentrated loads.

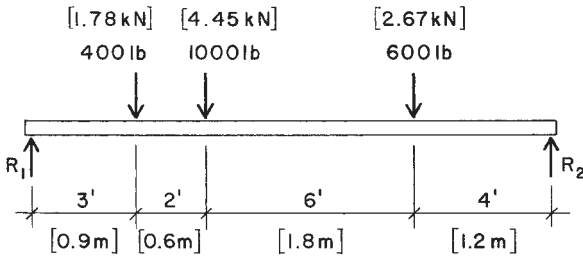


Figure 2.33 Example 10.

*Solution:* Regardless of the type or number of loads, the procedure is the same. Thus, considering the right reaction as the center of moments,

$$\Sigma M = 0 = +(R_1 \times 15) - (400 \times 12) - (1000 \times 10) - (600 \times 4)$$

Thus,

$$R_1 = \frac{4800 + 10,000 + 2400}{15} = \frac{17,200}{15} = 1146.7 \text{ lb}$$

Using the same procedure with the left reaction as the center of moments,

$$R_2 = \frac{(400 \times 3) + (1000 \times 5) + (600 \times 11)}{15} = \frac{12,800}{15} = 853.3 \text{ lb}$$

And, for a check, the summation of vertical forces is

$$\Sigma F = +1146.7 - 400 - 1000 - 600 + 853.3 = 0$$

For any beam with two simple supports, the procedure is the same. Care must be taken, however, to note carefully the sign of the moments: that is, plus for clockwise moments and minus for counterclockwise moments about the selected center of moments. The following example has its supports drawn in from the ends of the beam, producing *cantilevered* or *overhanging* ends.

**Example 11.** Compute the reactions for the beam in Figure 2.34 with overhanging ends.

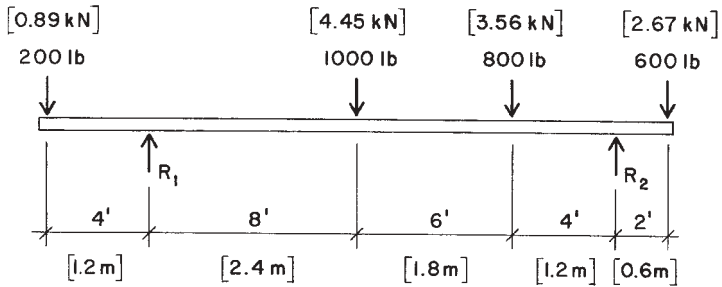


Figure 2.34 Example 11.

*Solution:* Using the same procedure as in the preceding two examples, first take moments about the right reaction; thus,

$$\Sigma M = 0 = -(200 \times 22) + (R_1 \times 18) - (1000 \times 10) - (800 \times 4) + (600 \times 2)$$

from which

$$R_1 = \frac{16,400}{18} = 911.1 \text{ lb}$$

Then, with a summation of moments about the left reaction,

$$\Sigma M = 0 = -(200 \times 4) + (1000 \times 8) + (800 \times 14) - (R_2 \times 18) + (600 \times 20)$$

Thus,

$$R_2 = \frac{30,400}{18} = 1688.9 \text{ lb}$$

A summation of vertical forces can be used to verify the answers.

**Example 12.** The simple beam shown in Figure 2.35a has a single concentrated load and a uniformly distributed load over a portion of the span. Compute the reactions.

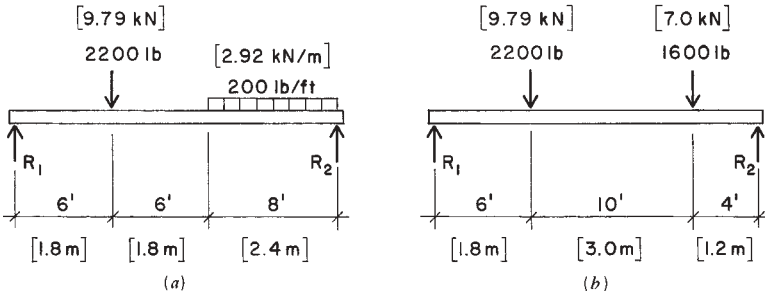


Figure 2.35 Example 12.

*Solution:* For a simplification in finding the reactions, it is common to consider the uniformly distributed load to be replaced by its resultant in the form of a single concentrated load at the center of the distributed load. The total of the uniform load is  $200 \times 8 = 1600$  lb, and the beam is thus considered to be as shown in Figure 2.35b. With the modified beam, a summation of moments about the right reaction is

$$\Sigma M = 0 = +(R_1 \times 20) - (2200 \times 14) - (1600 \times 4), \quad R_1 = \frac{37,200}{20} = 1860 \text{ lb}$$

A summation of moments about the left reaction will determine a value of 1940 lb for  $R_2$ , and a summation of vertical forces may be used to verify the answers.

This shortcut, consisting of replacing the distributed load by its resultant, is acceptable for finding the reactions, but the real nature of the distributed load must be considered for other investigations of the beam, as will be demonstrated in some of the later chapters.

**Problems 2.12.B–G**

Compute the reactions for the beams shown in Figures 2.36b–g.

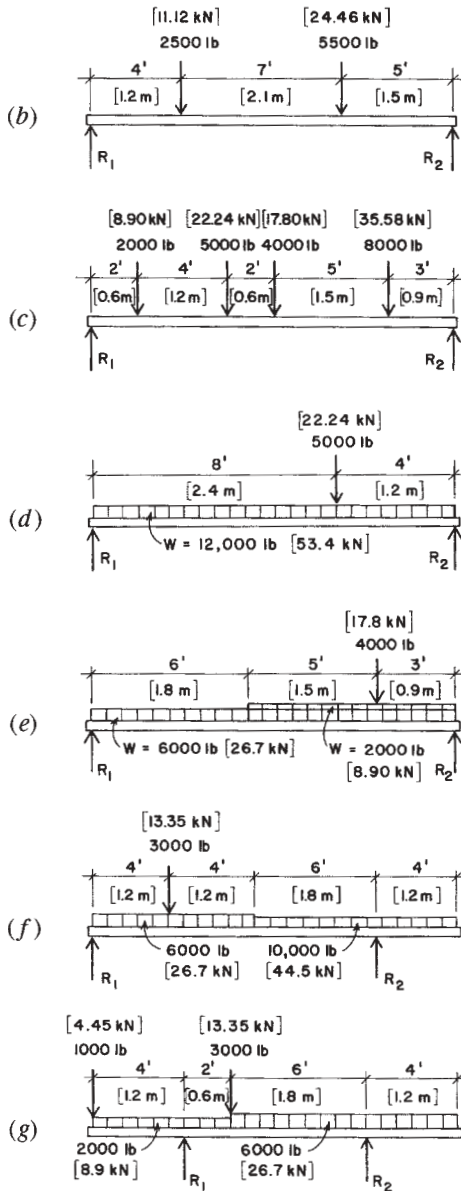


Figure 2.36 Problems 2.12.B–G.

# 3

---

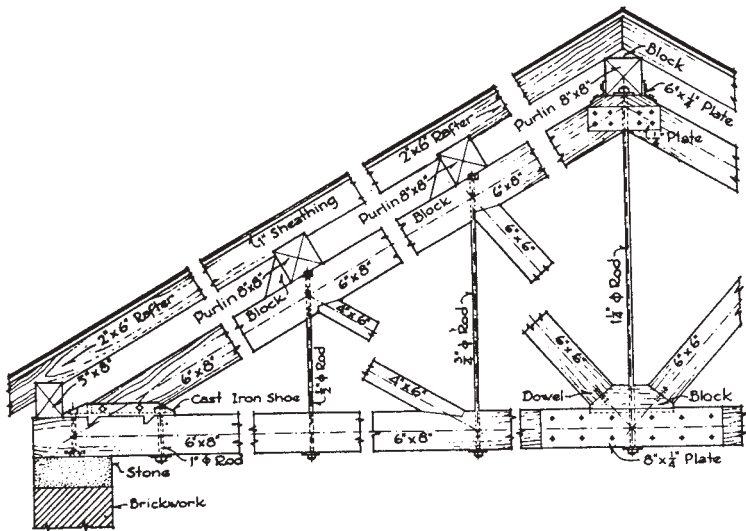
## ANALYSIS OF TRUSSES

---

Planar trusses, comprised of linear elements assembled in triangulated frameworks, have been used for spanning structures in buildings for many centuries. Figure 3.1 shows a form of construction used for such a truss in the early twentieth century. While construction materials, details, and processes have changed considerably, this classic form of truss is still widely used. Investigation for internal forces in such trusses is typically performed by simple analytical procedures using the basic methods illustrated in the preceding chapters. In this chapter, these procedures are demonstrated, using both graphical and algebraic methods of solution.

### 3.1 GRAPHICAL ANALYSIS OF TRUSSES

When the so-called *method of joints* is used, finding the internal forces in the members of a planar truss consists of solving a series of concurrent force systems. Figure 3.2, at the top, shows a truss with the truss form, the loads, and the reactions displayed in a space diagram. Below the space diagram is a figure consisting of the free-body diagrams of the

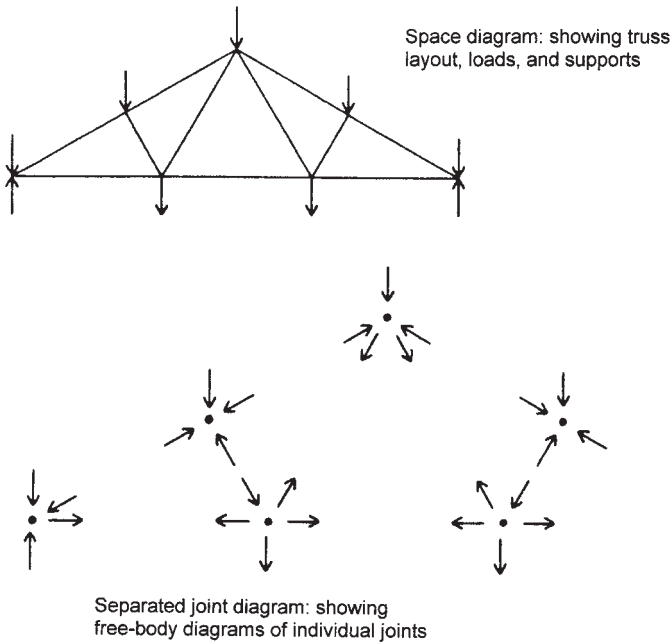


**Figure 3.1** Details of an early twentieth century timber truss. Reproduced from *Materials and Methods of Construction*, by C. Gay and H. Parker, 1932, with permission of the publisher, John Wiley & Sons, New York. This is a classic truss pattern still in frequent use, although neither the forms of the members—steel rods and solid timbers—nor any of the joint details are likely to be used today.

individual joints of the truss. These are arranged in the same manner as they are in the truss in order to show their interrelationships. However, each joint constitutes a complete concurrent planar force system that must have its independent equilibrium. “Solving” the problem consists of determining the equilibrium conditions for all of the joints. The procedures used for this solution are now illustrated.

Figure 3.3 shows a single-span planar truss that is subjected to vertical gravity loads. This example will be used to illustrate the procedures for determining the internal forces in the truss, that is, the tension and compression forces in the individual members of the truss. The space diagram in the figure shows the truss form and dimensions, the support conditions, and the loads. The letters on the space diagram identify individual forces at the truss joints, as discussed in Section 2.8. The sequence of placement of the letters is arbitrary, the only necessary consideration being to place a letter in each space between the loads and the individual





**Figure 3.2** Examples of diagrams used to represent trusses and their actions.

truss members so that each force at a joint can be identified by a two-letter symbol.

The separated joint diagram in the figure provides a useful means for visualization of the complete force system at each joint as well as the interrelation of the joints through the truss members. The individual forces at each joint are designated by two-letter symbols that are obtained by simply reading around the joint in the space diagram in a clockwise direction. Note that the two-letter symbols are reversed at the opposite ends of each of the truss members. Thus, the top chord member at the left end of the truss is designated as *BI* when shown in the joint at the left support (joint 1) and is designated as *IB* when shown in the first interior upper chord joint (joint 2). The purpose of this procedure will be demonstrated in the following explanation of the graphical analysis.

The third diagram in Figure 3.3 is a composite force polygon for the external and internal forces in the truss. It is called a Maxwell diagram

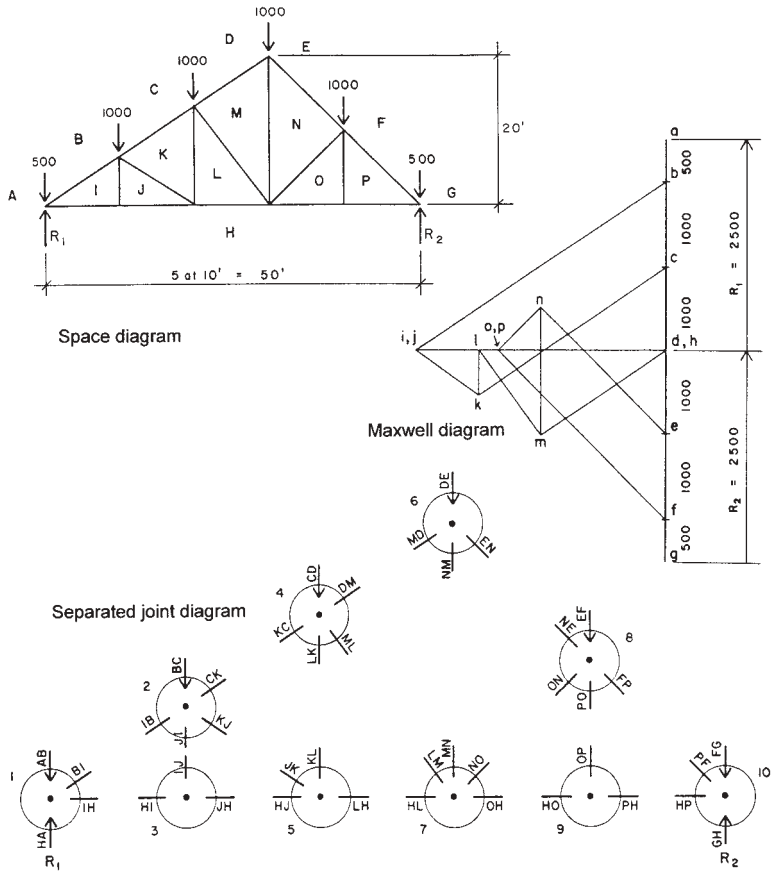


Figure 3.3 Examples of graphic diagrams for a planar truss.

after one of its early promoters, James Maxwell, a British engineer. The construction of this diagram constitutes a complete solution for the magnitudes and senses of the internal forces in the truss. The procedure for this construction is as follows.

1. *Construct the force polygon for the external forces.* Before this can be done, the values for the reactions must be found. There are graphic techniques for finding the reactions, but it is usually much simpler and faster to find them with an algebraic solution.

In this example, although the truss is not symmetrical, the loading is, and it may simply be observed that the reactions are each equal to one-half of the total load on the truss, or  $5000 \div 2 = 2500$  lb. Since the external forces in this case are all in a single direction, the force polygon for the external forces is actually a straight line. Using the two-letter symbols for the forces and starting with the letter *A* at the left end, we read the force sequence by moving in a clockwise direction around the outside of the truss. The loads are thus read as *AB*, *BC*, *CD*, *DE*, *EF*, and *FG*, and the two reactions are read as *GH* and *HA*. Beginning at *A* on the Maxwell diagram, the force vector sequence for the external forces is read from *A* to *B*, *B* to *C*, *C* to *D*, and so on, ending back at *A*, which shows that the force polygon closes and the external forces are in the necessary state of static equilibrium. Note that we have pulled the vectors for the reactions off to the side in the diagram to indicate them more clearly. Note also that we have used lowercase letters for the vector ends in the Maxwell diagram, whereas uppercase letters are used on the space diagram. The alphabetic correlation is thus retained (*A* to *a*), while any possible confusion between the two diagrams is prevented. The letters on the space diagram designate open spaces, while the letters on the Maxwell diagram designate points of intersection of lines.

2. *Construct the force polygons for the individual joints.* The graphic procedure for this consists of locating the points on the Maxwell diagram that correspond to the remaining letters, *I* through *P*, on the space diagram. When all the lettered points on the diagram are located, the complete force polygon for each joint may be read on the diagram. In order to locate these points, we use two relationships. The first is that the truss members can resist only forces that are parallel to the members' positioned directions. Thus, we know the directions of all the internal forces. The second relationship is a simple one from plane geometry: a point may be located at the intersection of two lines. Consider the forces at joint 1, as shown in the separated joint diagram in Figure 3.3. Note that there are four forces and that two of them are known (the load and the reaction) and two are unknown (the internal forces in the truss members). The force polygon for this joint, as shown on the Maxwell diagram, is read as *ABIHA*. *AB* represents the load, *BI* the force in the upper chord member, *IH*

the force in the lower chord member, and  $HA$  the reaction. Thus, the location of point  $i$  on the Maxwell diagram is determined by noting that  $i$  must be in a horizontal direction from  $h$  (corresponding to the horizontal position of the lower chord) and in a direction from  $b$  that is parallel to the position of the upper chord.

The remaining points on the Maxwell diagram are found by the same process, using two known points on the diagram to project lines of known direction whose intersection will determine the location of an unknown point. Once all the points are located, the diagram is complete and can be used to find the magnitude and sense of each internal force. The process for construction of the Maxwell diagram typically consists of moving from joint to joint along the truss. Once one of the letters for an internal space is determined on the Maxwell diagram, it may be used as a known point for finding the letter for an adjacent space on the space diagram. The only limitation of the process is that it is not possible to find more than one unknown point on the Maxwell diagram for any single joint. Consider joint 7 on the separated joint diagram in Figure 3.3. To solve this joint first, knowing only the locations of letters  $a$  through  $h$  on the Maxwell diagram, it is necessary to locate four unknown points:  $l$ ,  $m$ ,  $n$ , and  $o$ . This is three more unknowns than can be determined in a single step, so three of the unknowns must be found by using other joints.

Solving for a single unknown point on the Maxwell diagram corresponds to finding two unknown forces at a joint, since each letter on the space diagram is used twice in the force identification for the internal forces. Thus for joint 1 in the previous example, the letter  $I$  is part of the identity of forces  $BI$  and  $IH$ , as shown on the separated joint diagram. The graphic determination of single points on the Maxwell diagram, therefore, is analogous to finding two unknown quantities in an algebraic solution. As discussed previously, two unknowns are the maximum that can be solved for in equilibrium of a coplanar, concurrent force system, which is the condition of the individual joints in the truss.

When the Maxwell diagram is completed, the internal forces can be read from the diagram as follows:

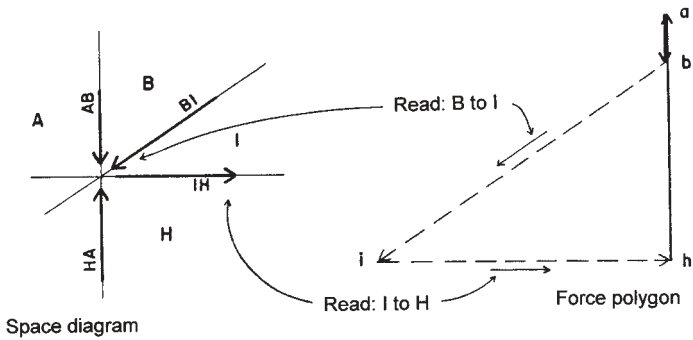
1. The magnitude is determined by measuring the length of the line in the diagram, using the scale that was used to plot the vectors for the external forces.

2. The sense of individual forces is determined by reading the forces in clockwise sequence around a single joint in the space diagram and tracing the same letter sequences on the Maxwell diagram.

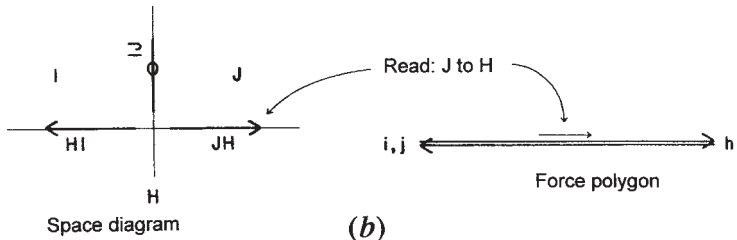
Figure 3.4*a* shows the force system at joint 1 and the force polygon for these forces as taken from the Maxwell diagram. The forces known initially are shown as solid lines on the force polygon, and the unknown forces are shown as dashed lines. Starting with letter *A* on the force system, we read the forces in a clockwise sequence as *AB*, *BI*, *IH*, and *HA*. Note that, on the Maxwell diagram, moving from *a* to *b* is moving in the order of the sense of the force, that is from tail to end of the force vector that represents the external load on the joint. Using this sequence on the Maxwell diagram, this force sense flow will be a continuous one. Thus, reading from *b* to *i* on the Maxwell diagram is reading from tail to head of the force vector, which indicates that force *BI* has its head at the left end. Transferring this sense indication from the Maxwell diagram to the joint diagram indicates that force *BI* is in compression; that is, it is pushing, rather than pulling, on the joint. Reading from *i* to *h* on the Maxwell diagram shows that the arrowhead for this vector is on the right, which translates to a tension effect on the joint diagram.

Having solved for the forces at joint 1 as described, the fact that the forces in truss members *BI* and *IH* are known can be used to consider the adjacent joints, 2 and 3. However, it should be noted that the sense reverses at the opposite ends of the members in the joint diagrams. Referring to the separated joint diagram in Figure 3.3, if the upper chord member shown as force *BI* in joint 1 is in compression, its arrowhead is at the lower left end in the diagram for joint 1, as shown in Figure 3.4*a*. However, when the same force is shown as *IB* at joint 2, its pushing effect on the joint will be indicated by having the arrowhead at the upper right end in the diagram for joint 2. Similarly, the tension effect of the lower chord is shown in joint 1 by placing the arrowhead on the right end of the force *IH*, but the same tension force will be indicated in joint 3 by placing the arrowhead on the left end of the vector for force *HI*.

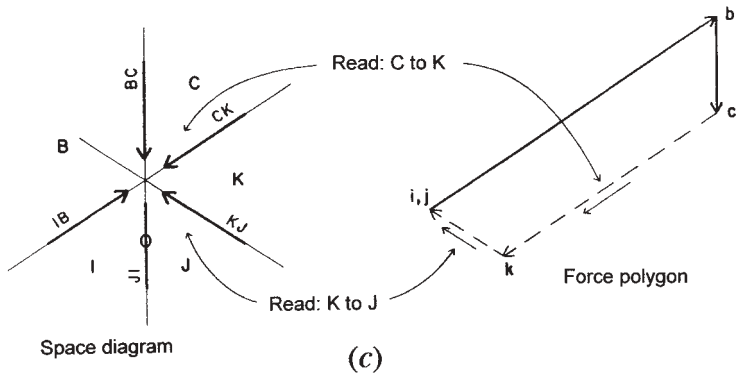
If the solution sequence of solving joint 1 and then joint 2 is chosen, it is now possible to transfer the known force in the upper chord to joint 2. Thus, the solution for the five forces at joint 2 is reduced to finding three unknowns, since the load *BC* and the chord force *IB* are now known. However, it is still not possible to solve joint 2, since there are two unknown points on the Maxwell diagram (*k* and *j*) corresponding to



(a)



(b)



(c)

Figure 3.4 Graphic solutions for joints 1, 2, and 3. (a) Joint 1. (b) Joint 3. (c) Joint 2.

the three unknown forces. An option, therefore, is to proceed from joint 1 to joint 3, at which there are now only two unknown forces. On the Maxwell diagram, the single unknown point  $j$  can be found by projecting vector  $IJ$  vertically from  $i$  and projecting vector  $JH$  horizontally from point  $h$ . Since point  $i$  is also located horizontally from point  $h$ , this shows that the vector  $IJ$  has zero magnitude, since both  $i$  and  $j$  must be on a horizontal line from  $h$  in the Maxwell diagram. This indicates that there is actually no stress in this truss member for this loading condition and that points  $i$  and  $j$  are coincident on the Maxwell diagram. The joint force diagram and the force polygon for joint 3 are as shown in Figure 3.4*b*. In the joint force diagram, place a zero, rather than an arrowhead, on the vector line for  $IJ$  to indicate the zero stress condition. In the force polygon in Figure 3.4*b*, the two force vectors are slightly separated for clarity, although they are actually coincident on the same line.

Having solved for the forces at joint 3, proceed to joint 2, since there remain only two unknown forces at this joint. The forces at the joint and the force polygon for joint 2 are shown in Figure 3.4*c*. As for joint 1, read the force polygon in a sequence determined by reading clockwise around the joint:  $BCKJIB$ . Following the continuous direction of the force arrows on the force polygon in this sequence, it is possible to establish the sense for the two forces  $CK$  and  $KJ$ .

It is possible to proceed from one end and to work continuously across the truss from joint to joint to construct the Maxwell diagram in this example. The sequence in terms of locating points on the Maxwell diagram would be  $i-j-k-l-m-n-o-p$ , which would be accomplished by solving the joints in the following sequence: 1, 3, 2, 5, 4, 6, 7, 9, 8. However, it is advisable to minimize the error in graphic construction by working from both ends of the truss. Thus, a better procedure would be to find points  $i-j-k-l-m$ , working from the left end of the truss, and then to find points  $p-o-n-m$ , working from the right end. This would result in finding two locations for the point  $m$ , whose separation constitutes the error in drafting accuracy.

**Problems 3.1.A, B**

Using a Maxwell diagram, find the internal forces in the trusses in Figure 3.5.

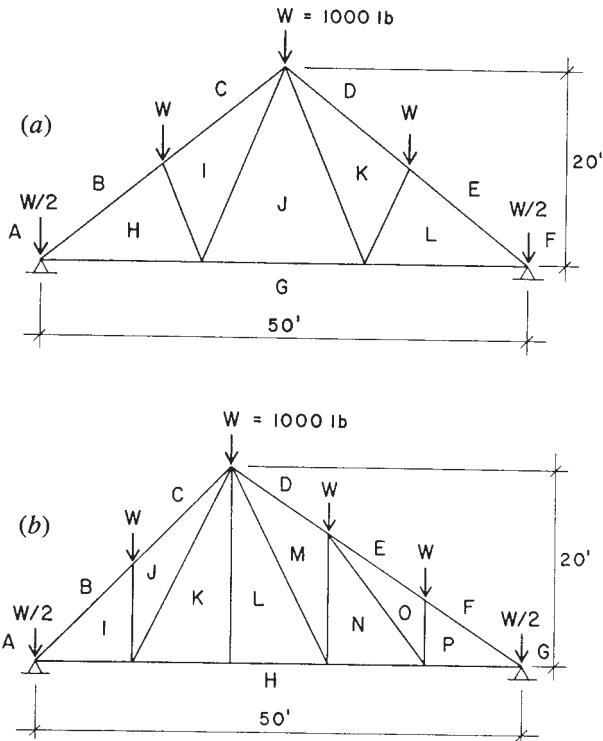


Figure 3.5 Problems 3.1.A, B.

### 3.2 ALGEBRAIC ANALYSIS OF TRUSSES

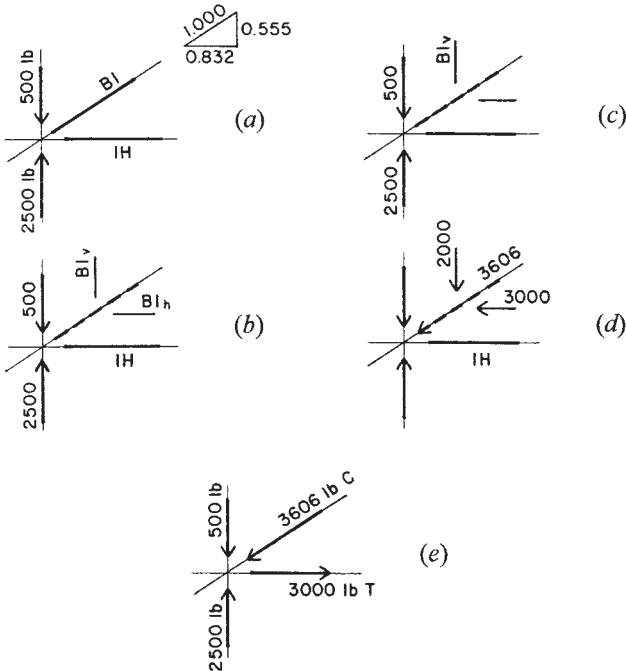
Graphical solution for the internal forces in a truss using the Maxwell diagram corresponds essentially to an algebraic solution by the *method of joints*. This method consists of solving the concentric force systems at the individual joints using simple force equilibrium equations. The process will be illustrated using the previous example.

As with the graphic solution, first determine the external forces, consisting of the loads and the reactions. Then proceed to consider the equilibrium of the individual joints, following a sequence as in the graphic solution. The limitation of this sequence, corresponding to the limit of



finding only one unknown point in the Maxwell diagram, is that only two unknown forces at any single joint can be found in a single step. (Two conditions of equilibrium produce two equations.) Referring to Figure 3.6, the solution for joint 1 is as follows.

The force system for the joint is drawn with the sense and magnitude of the known forces shown, but with the unknown internal forces represented by lines without arrowheads, since their senses and magnitudes initially are unknown (Figure 3.6*a*). For forces that are not vertical or horizontal, replace the forces with their horizontal and vertical components. Then consider the two conditions necessary for the equilibrium of the system: the sum of the vertical forces is zero and the sum of the horizontal forces is zero.



**Figure 3.6** Algebraic solution for joint 1. (a) The initial condition. (b) Unknowns reduced to components. (c) Solution of vertical equilibrium. (d) Solution of horizontal equilibrium. (e) Final answer.

If the algebraic solution is performed carefully, the sense of the forces will be determined automatically. However, it is recommended that, whenever possible, the sense be predetermined by simple observations of the joint conditions, as will be illustrated in the solutions.

The problem to be solved at joint 1 is as shown in Figure 3.6*a*. In Figure 3.6*b*, the system is shown with all forces expressed as vertical and horizontal components. Note that, although this now increases the number of unknowns to three ( $IH$ ,  $BI_v$ , and  $BI_h$ ), there is a numeric relationship between the two components of  $BI$ . When this condition is added to the two algebraic conditions for equilibrium, the number of usable relationships totals three, so that the necessary conditions to solve for the three unknowns are present.

The condition for vertical equilibrium is shown in Figure 3.6*c*. Since the horizontal forces do not affect the vertical equilibrium, the balance is between the load, the reaction, and the vertical component of the force in the upper chord. Simple observation of the forces and the known magnitudes makes it obvious that force  $BI_v$  must act downward, indicating that  $BI$  is a compression force. Thus, the sense of  $BI$  is established by simple visual inspection of the joint, and the algebraic equation for vertical equilibrium (with upward force considered positive) is

$$\Sigma F_v = 0 = +2500 - 500 - BI_v$$

From this equation,  $BI_v$  is determined to have a magnitude of 2000 lb. Using the known relationships between  $BI$ ,  $BI_v$ , and  $BI_h$ , the values of these three quantities can be determined if any one of them is known. Thus,

$$\frac{BI}{1.000} = \frac{BI_v}{0.555} = \frac{BI_h}{0.832}$$

from which

$$BI_h = \frac{0.832}{0.555}(2000) = 3000 \text{ lb}$$

and

$$BI = \frac{1.000}{0.555}(2000) = 3606 \text{ lb}$$

The results of the analysis to this point are shown in Figure 3.6*d*, from which it may be observed that the conditions for equilibrium of the horizontal forces can be expressed. Stated algebraically (with force sense toward the right considered positive), the condition is

$$\Sigma F_h = 0 = IH - 3000$$

from which it is established that the force in *IH* is 3000 lb.

The final solution for the joint is then as shown in Figure 3.6*e*. On this diagram, the internal forces are identified as to sense by using *C* to indicate compression and *T* to indicate tension.

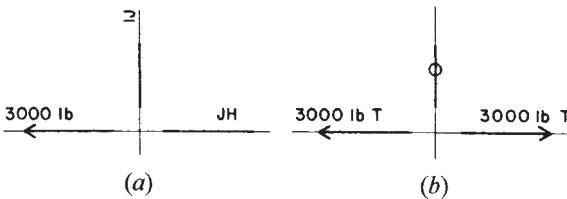
As with the graphic solution, proceed to consider the forces at joint 3. The initial condition at this joint is as shown in Figure 3.7*a*, with the single known force in member *HI* and the two unknown forces in *IJ* and *JH*. Since the forces at this joint are all vertical and horizontal, there is no need to use components. Consideration of vertical equilibrium makes it obvious that it is not possible to have a force in member *IJ*. Stated algebraically, the condition for vertical equilibrium is

$$\Sigma F_v = 0 = IJ \quad (\text{since } IJ \text{ is the only force})$$

It is equally obvious that the force in *JH* must be equal and opposite to that in *HI*, since they are the only two horizontal forces. That is, stated algebraically,

$$\Sigma F_h = 0 = JH - 3000$$

The final answer for the forces at joint 3 is as shown in Figure 3.7*b*. Note the convention for indicating a truss member with no internal force.



**Figure 3.7** Algebraic solution for joint 3. (a) The initial condition. (b) The solution.

Now proceed to consider joint 2; the initial condition is as shown in Figure 3.8*a*. Of the five forces at the joint, only two remain unknown. Following the procedure for joint 1, first resolve the forces into their vertical and horizontal components, as shown in Figure 3.8*b*.

Since the sense of forces  $CK$  and  $KJ$  is unknown, use the procedure of considering them to be positive until proven otherwise. That is, if they are entered into the algebraic equations with an assumed sense, and the solution produces a negative answer, then the assumption was wrong. However, be careful to be consistent with the sense of the force vectors, as the following solution will illustrate.

Arbitrarily assume that force  $CK$  is in compression and force  $KJ$  is in tension. If this is so, the forces and their components will be as shown in Figure 3.8*c*. Then consider the conditions for vertical equilibrium; the forces involved will be those shown in Figure 3.8*d*, and the equation for vertical equilibrium will be

$$\Sigma F_v = 0 = -1000 + 2000 - CK_v - KJ_v$$

or

$$0 = +1000 - 0.555CK - 0.555KJ \quad (3.2.1)$$

Now consider the conditions for horizontal equilibrium; the forces will be as shown in Figure 3.8*e*, and the equation will be

$$\Sigma F_h = 0 = +3000 - CK_h + KJ_h$$

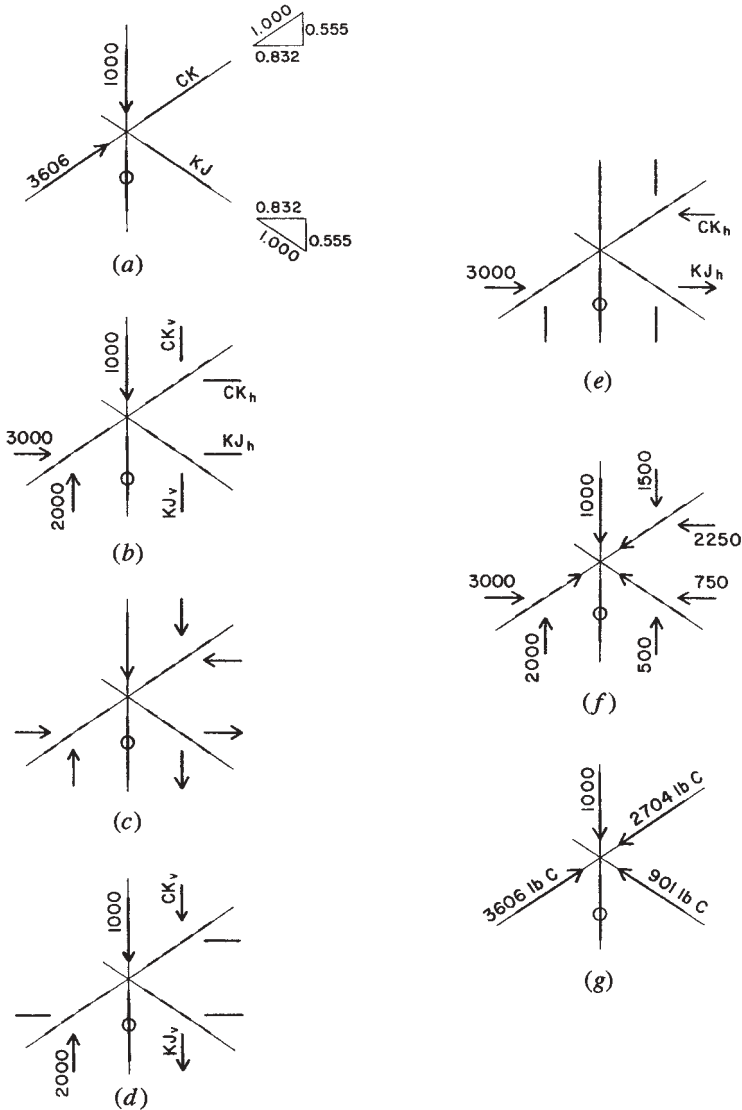
or

$$0 = +3000 - 0.832CK + 0.832KJ \quad (3.2.2)$$

Note the consistency of the algebraic signs and the sense of the force vectors, with positive forces considered as upward and toward the right. Now solve these two equations simultaneously for the two unknown forces, as follows:

1. Multiply equation (3.2.1) by 0.832/0.555.

$$0 = \frac{0.832}{0.555}(+1000) + \frac{0.832}{0.555}(-0.555CK) + \frac{0.832}{0.555}(-0.555KJ)$$



**Figure 3.8** Algebraic solution for joint 2. (a) The initial condition. (b) Unknowns reduced to components. (c) Assumed sense of the unknowns for the algebraic solution. (d) Solution of vertical equilibrium. (e) Solution of horizontal equilibrium. (f) Final answer in components. (g) Final answer in true forces.

or

$$0 = + 1500 - 0.832CK - 0.832KJ$$

2. Add this equation to equation (3.2.2) and solve for  $CK$ .

$$0 = +4500 - 1.664CK, \quad CK = \frac{4500}{1.664} = 2704 \text{ lb}$$

Note that the assumed sense of compression in  $CK$  is correct, since the algebraic solution produces a positive answer. Substituting this value for  $CK$  in equation (3.2.1),

$$0 = + 1000 - 0.555(2704) - 0.555(KJ)$$

and

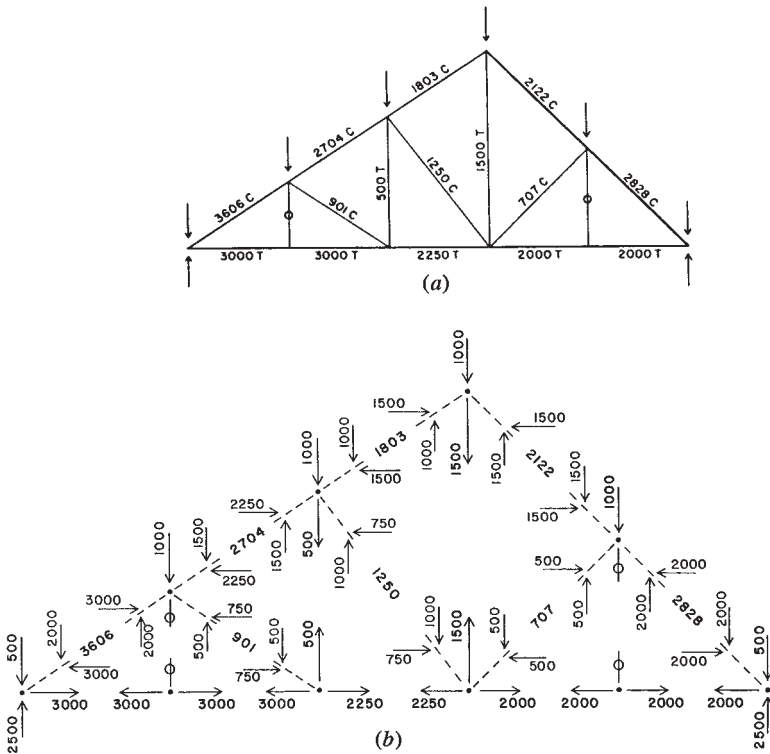
$$KJ = \frac{500}{0.555} = -901 \text{ lb}$$

Since the algebraic solution produces a negative quantity for  $KJ$ , the assumed sense for  $KJ$  is wrong and the member is actually in compression.

The final answers for the forces at joint 2 are as shown in Figure 3.8g. In order to verify that equilibrium exists, however, the forces are shown in the form of their vertical and horizontal components in Figure 3.8f.

When all of the internal forces have been determined for the truss, the results may be recorded or displayed in a number of ways. The most direct way is to display them on a scaled diagram of the truss, as shown in Figure 3.9a. The force magnitudes are recorded next to each member with the sense shown as  $T$  for tension or  $C$  for compression. Zero stress members are indicated by the conventional symbol consisting of a zero placed directly on the member.

When solving by the algebraic method of joints, the results may be recorded on a separated joint diagram, as shown in Figure 3.9b. If the values for the vertical and horizontal components of force in sloping members are shown, it is a simple matter to verify the equilibrium of the individual joints.



**Figure 3.9** Presentation of the internal forces in the truss. (a) Member forces. (b) Separated joint diagram.

**Problems 3.2.A, B**

Using the algebraic method of joints, find the internal forces in the trusses in Figure 3.5.

**3.3 THE METHOD OF SECTIONS**

Figure 3.10 shows a simple-span flat-chorded truss with a vertical loading on the top chord joints. The Maxwell diagram for this loading and the answers for the internal forces are also shown in the figure. This solution

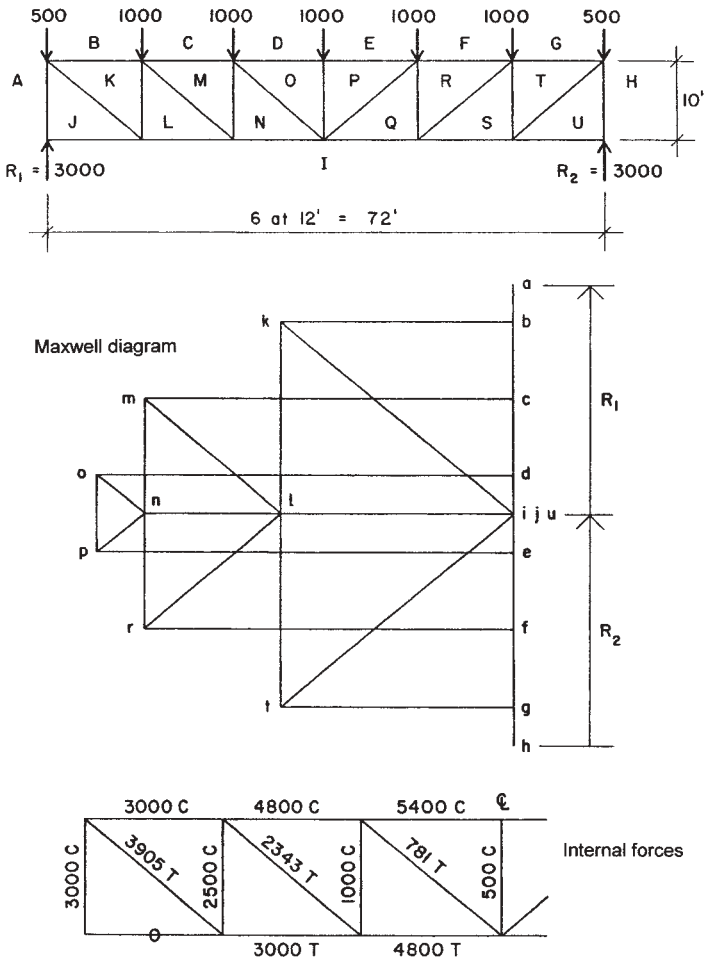


Figure 3.10 Graphic solution for the flat-chorded truss.

is provided as a reference for comparison with the results that will be obtained by the method of sections.

In Figure 3.11, the truss is shown with a cut plane passing vertically through the third panel. The free-body diagram of the portion of the truss to the left of this cut plane is shown in Figure 3.11a. The internal forces



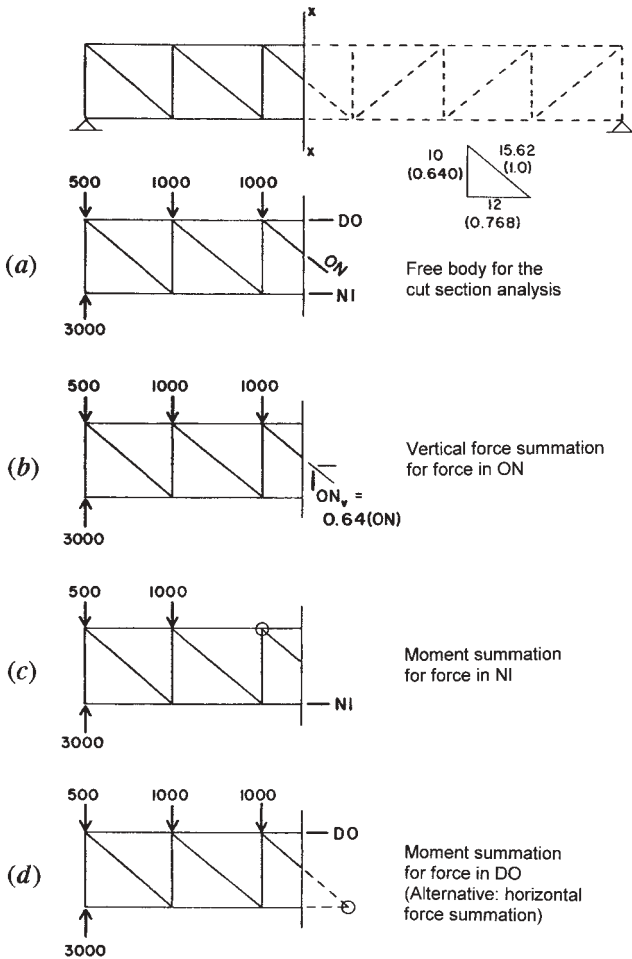


Figure 3.11 Investigation of the truss by the method of sections.

in the three cut members become external forces on this free body, and their values may be found using the following analysis of the static equilibrium of the free body.

In Figure 3.11*b*, we observe the condition for vertical equilibrium. Since *ON* is the only cut member with a vertical force component, it

must be used to balance the other external forces, resulting in the value for  $ON_v$  of 500 lb acting downward. With the angle of inclination of this member known, the horizontal component and the true force in the member can now be found.

We next consider a condition of equilibrium of moments, selecting a center of moments as a point that will eliminate all but one of the unknown forces, thus producing a single algebraic equation with only one unknown. Selecting the top chord joint, as shown in Figure 3.11c, both the force in the top chord and in member  $ON$  are eliminated. Then the only remaining unknown force is that in the bottom chord (member  $NI$ ) and the summation is

$$\Sigma M = 0 = +(3000 \times 24) - (500 \times 24) - (1000 \times 12) - (NI \times 10)$$

or

$$10(NI) = +72,000 - 12,000 - 12,000 = +48,000$$

$$NI = \frac{48,000}{10} = 4800 \text{ lb}$$

Note that the sense of the force in  $NI$  was assumed to be tension, and the sign used for  $NI$  in the moment summation was based on this assumption.

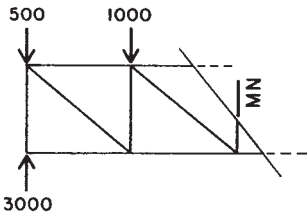
One way to find the force in the top chord is to do a summation of horizontal forces, since the horizontal component of  $ON$  and the force in  $NI$  are now known. An alternative would be to use another moment summation, this time selecting the bottom chord joint shown in Figure 3.11d in order to eliminate  $IN$  and  $ON$  from the summation equation.

$$\Sigma M_2 = 0 = +(3000 \times 36) - (500 \times 36) - (1000 \times 24) - (1000 \times 12) - (DO \times 10)$$

Thus,

$$DO = \frac{54,000}{10} = 5400 \text{ lb}$$

The forces in all of the horizontal and diagonal members of the truss may be found by cutting sections and writing equilibrium equations similar to the process just illustrated. In order to find the forces in the vertical members, it is possible to cut the truss with an angled plane, as shown



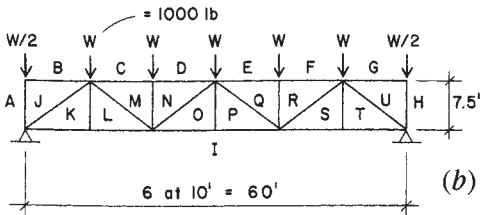
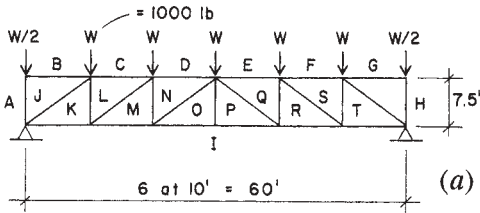
**Figure 3.12** Cut section used to find the force in the vertical members.

in Figure 3.12. A summation of vertical forces on this free body will yield the internal force of 1500 lb in compression in member *MN*.

The method of sections is sometimes useful when it is desired to find the internal force in individual members of a truss without doing a complete analysis for all of the members.

**Problems 3.3.A, B**

Find the internal forces in the members of the trusses in Figure 3.13 using: (1) a Maxwell diagram; (2) the algebraic method of sections.



**Figure 3.13** Problems 3.3.A, B.

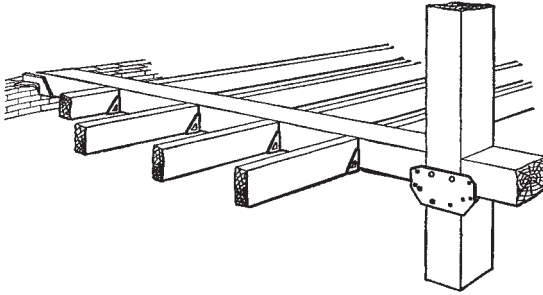
# 4

---

## ANALYSIS OF BEAMS

---

A beam is a structural member that resists transverse loads. The supports for beams are usually at or near the ends, and the supporting upward forces are called reactions. The loads acting on a beam tend to *bend* it rather than shorten or lengthen it. *Girder* is the name given to a beam that supports smaller beams; all girders are beams insofar as their structural action is concerned. For construction usage, beams carry various names, depending on the form of construction; these include *purlin*, *joist*, *rafter*, *lintel*, *header*, and *girt*. Figure 4.1 shows a floor structure achieved with closely spaced wood beams (called *joists* when occurring in this situation) that are supported by larger wood beams, which are in turn supported by masonry bearing walls or wood columns. This classic system is extensively used, although the materials and elements utilized and the details of the construction all change over time.



**Figure 4.1** Beams were the earliest elements used to achieve spanning structures—first in the form of untreated cut tree trunks, and then, as tools were developed, in more useful shaped forms. Large beams used for long spans usually carry point loadings from other structural elements, such as the joists shown here hung from the timber beam. Lighter beams, such as the joists, typically carry a uniformly distributed load from a directly attached deck. Although developed in wood, this classic system is emulated in steel and concrete. Reproduced from *Architects and Builders Handbook*, by H. Parker and F. Kidder, 1931, with permission of the publisher, John Wiley & Sons, New York.

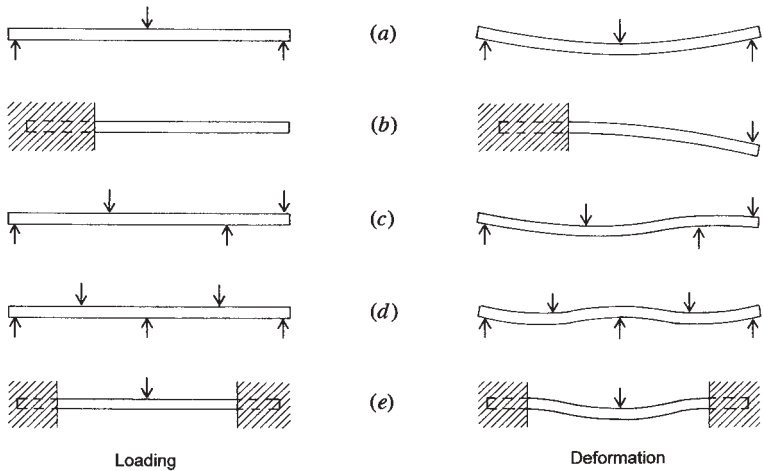
## 4.1 TYPES OF BEAMS

There are, in general, five types of beams, which are identified by the number, kind, and position of the supports. Figure 4.2 shows diagrammatically the different types, and also the shape each beam tends to assume as it bends (deforms) under the loading. In ordinary steel or reinforced concrete beams, these deformations are not usually visible to the eye, but some deformation is always present.

A *simple beam* rests on a support at each end, the ends of the beam being free to rotate (Figure 4.2a).

A *cantilever beam* is supported at one end only. A beam embedded in a wall and projecting beyond the face of the wall is a typical example (Figure 4.2b).

An *overhanging beam* is a beam whose end or ends project beyond its supports. Figure 4.2c indicates a beam overhanging one support only.



**Figure 4.2** Types of beams. (a) Simple. (b) Cantilever. (c) Overhanging. (d) Continuous. (e) Restrained.

A *continuous beam* rests on more than two supports (Figure 4.2d).

Continuous beams are commonly used in reinforced concrete and welded steel construction.

A *restrained beam* has one or both ends restrained or fixed against rotation (Figure 4.2e).

## 4.2 LOADS AND REACTIONS

Beams are acted on by external forces that consist of the loads and the reaction forces developed by the beam's supports. The two types of loads that commonly occur on beams are called *concentrated* and *distributed*. A concentrated load is assumed to act at a definite point; such a load is that caused when one beam supports another beam. A distributed load is one that acts over a considerable length of the beam; such a load is one caused by a floor deck supported directly by a beam. If the distributed load exerts a force of equal magnitude for each unit of length of the beam, it is known as a *uniformly distributed load*. The weight of a beam

is a uniformly distributed load that extends over the entire length of the beam. However, some uniformly distributed loadings supported by the beam may extend over only a portion of the beam length.

Reactions are the upward forces acting at the supports that hold in equilibrium the downward forces or loads. The left and right reactions of a simple beam are usually called  $R_1$  and  $R_2$ , respectively. Determination of reactions for simple beams is achieved with the use of equilibrium conditions for parallel force systems, as demonstrated in Section 2.12.

Figure 4.3*a* shows a portion of a floor framing plan. The diagonal crosshatching represents the area supported by one of the beams. This area is  $8 \times 20$  ft, the dimensions of the beam spacing and the beam span. The beam is supported at each end by girders that span between the supporting columns. If the total load on the crosshatched area is 100 psf, then the total load on the beam is determined as

$$W = 8 \times 20 \times 100 = 16,000 \text{ lb or 16 kips}$$

It is common to designate this total load as  $W$ , using the capital form of the letter. However, for a uniformly distributed load, the loading may also be expressed in the form of a unit load per unit of length of the beam. This unit load is designated by  $w$ , using the lowercase form. Thus, for this beam,

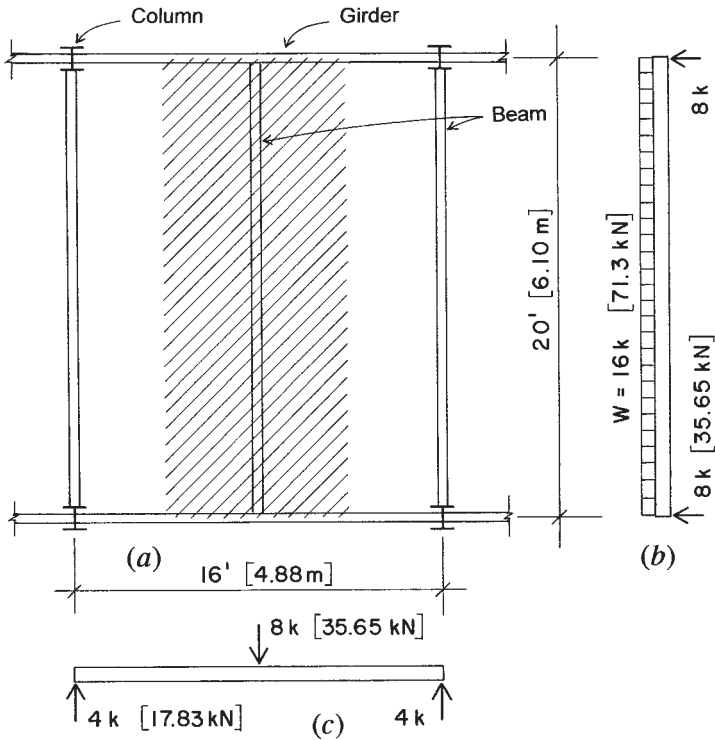
$$w = \frac{16,000}{20} = 800 \text{ lb/ft or 800 plf (pounds per lineal foot)}$$

For the beam in Figure 4.3, the load is symmetrically placed, and the two reactions will thus each be one-half of the total load. The reactions are developed as concentrated loads on the girders. The loading diagrams for the beam and girder are as shown in Figures 4.3*b* and *c*.

For unsymmetrical beam loadings, the reaction forces can be determined by the procedures demonstrated in Section 2.12.

### 4.3 SHEAR IN BEAMS

Figure 4.4*a* represents a simple beam with a uniformly distributed load over its entire length. Examination of an actual beam so loaded would

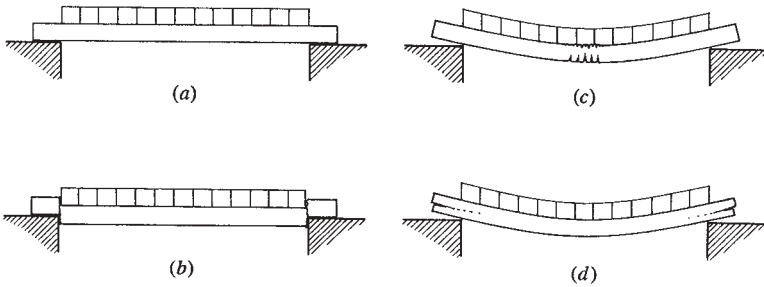


**Figure 4.3** Determination of beam loads and display of the loaded beams for a framing system. (a) Plan. (b) Loading diagram for the beam. (c) Loading diagram for the girder.

probably not reveal any effects of the loading on the beam. However, there are three distinct major tendencies for the beam to fail. Figures 4.4*b–d* illustrate the three phenomena.

First, there is a tendency for the beam to fail by dropping between the supports (Figure 4.4*b*). This is called *vertical shear*. Second, the beam may fail by *bending* (Figure 4.4*c*). Third, there is a tendency in wood beams for the fibers of the beam to slide past each other in a horizontal direction (Figure 4.4*d*), an action described as *horizontal shear*. Naturally, a beam properly designed does not fail in any of the ways just mentioned, but these tendencies to fail are always present and must be considered in structural design.





**Figure 4.4** Characteristic forms of failure for a simple beam. (a) Beam with uniformly distributed load. (b) Vertical shear. (c) Bending. (d) Horizontal shear.

### Vertical Shear

Vertical shear is the tendency for one part of a beam to move vertically with respect to an adjacent part. The magnitude of the shear force at any section in the length of a beam is equal to the algebraic sum of the vertical forces on either side of the section. Vertical shear is usually represented by the letter  $V$ . In computing its values in the examples and problems, consider the forces to the left of the section, but keep in mind that the same resulting force magnitude will be obtained with the forces on the right. To find the magnitude of the vertical shear at any section in the length of a beam, simply add up the forces to the right or the left of the section. It follows from this procedure that the maximum value of the shear for simple beams is equal to the greater reaction.

**Example 1.** Figure 4.5a illustrates a simple beam with concentrated loads of 600 lb and 1000 lb. The problem is to find the value of the vertical shear at various points along the length of the beam. Although the weight of the beam constitutes a uniformly distributed load, it is neglected in this example.

**Solution:** The reactions are computed as previously described, and are found to be  $R_1 = 1000$  lb and  $R_2 = 600$  lb.

Consider next the value of the vertical shear  $V$  at an infinitely short distance to the right of  $R_1$ . Applying the rule that the shear is equal to the reaction minus the loads to the left of the section, we write

$$V = R_1 - 0, \quad \text{or } V = 1000 \text{ lb}$$

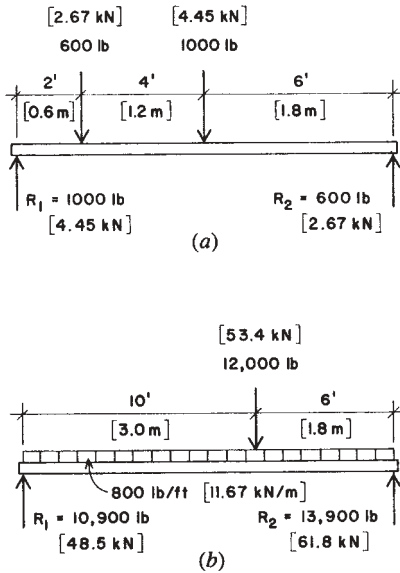


Figure 4.5 Examples 1 and 2.

The zero represents the value of the loads to the left of the section, which of course, is zero. Now take a section 1 ft to the right of  $R_1$ ; again

$$V_{(x=1)} = R_1 - 0, \quad \text{or } V_{(x=1)} = 1000 \text{ lb}$$

The subscript ( $x = 1$ ) indicates the position of the section at which the shear is taken, the distance of the section from  $R_1$ . At this section, the shear is still 1000 lb and has the same magnitude up to the 600-lb load.

The next section to consider is a very short distance to the right of the 600-lb load. At this section,

$$V_{(x=2+)} = 1000 - 600 = 400 \text{ lb}$$

Because there are no loads intervening, the shear continues to be the same magnitude up to the 1000-lb load. At a section a short distance to the right of the 1000-lb load,

$$V_{(x=6+)} = 1000 - (600 + 1000) = -600 \text{ lb}$$

This magnitude continues up to the right-hand reaction  $R_2$ .

**Example 2.** The beam shown in Figure 4.5*b* supports a concentrated load of 12,000 lb located 6 ft from  $R_2$  and a uniformly distributed load of 800 pounds per linear foot (lb/ft) over its entire length. Compute the value of vertical shear at various sections along the span.

*Solution:* By use of the equations of equilibrium, the reactions are determined to be  $R_1 = 10,900$  lb and  $R_2 = 13,900$  lb. Note that the total distributed load is  $800 \times 16 = 12,800$  lb. Now consider the vertical shear force at the following sections at a distance measured from the left support.

$$\begin{aligned} V_{(x=0)} &= 10,900 - 0 = 10,900 \text{ lb} \\ V_{(x=1)} &= 10,900 - (800 \times 1) = 10,100 \text{ lb} \\ V_{(x=5)} &= 10,900 - (800 \times 5) = 6900 \text{ lb} \\ V_{(x=10-)} &= 10,900 - (800 \times 10) = 2900 \text{ lb} \\ V_{(x=10+)} &= 10,900 - \{(800 \times 10) + 12,000\} = -9100 \text{ lb} \\ V_{(x=16)} &= 10,900 - \{(800 \times 16) + 12,000\} = -13,900 \end{aligned}$$

## Shear Diagrams

In the two preceding examples, the value of the shear at several sections along the length of the beams was computed. In order to visualize the results, it is common practice to plot these values on a diagram, called the *shear diagram*, which is constructed as explained below.

To make such a diagram, first draw the beam to scale and locate the loads. This has been done in Figures 4.6*a* and *b* by repeating the load diagrams of Figures 4.5*a* and *b*, respectively. Beneath the beam draw a horizontal baseline representing zero shear. Above and below this line, plot at any convenient scale the values of the shear at the various sections; the positive, or plus, values are placed above the line and the negative, or minus, values below. In Figure 4.6*a*, for instance, the value of the shear at  $R_1$  is +1000 lb. The shear continues to have the same value up to the load of 600 lb, at which point it drops to 400 lb. The same value continues up to the next load, 1000 lb, where it drops to -600 lb and continues to the right-hand reaction. Obviously, to draw a shear diagram, it is necessary to compute the values at significant points only. Having made the diagram, we may readily find the value of the shear at any section of the beam by scaling the vertical distance in the diagram. The shear diagram for the beam in Figure 4.6*b* is made in the same manner.

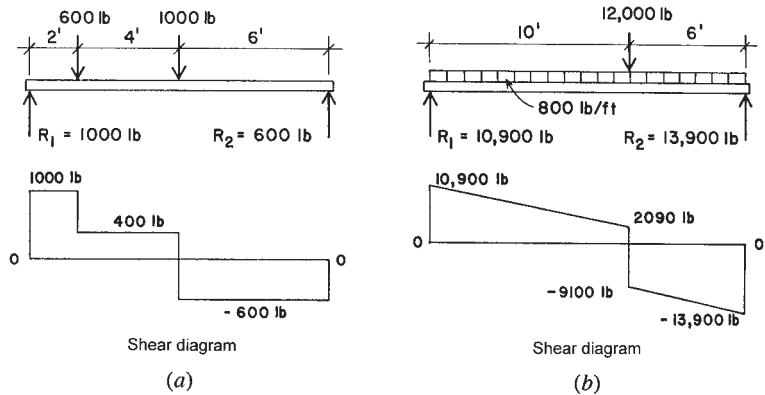


Figure 4.6 Construction of shear diagrams.

There are two important facts to note concerning the vertical shear. The first is the maximum value. The diagrams in each case confirm the earlier observation that the maximum shear is at the reaction having the greater value, and its magnitude is equal to that of the greater reaction. In Figure 4.6a, the maximum shear is 1000 lb, and in Figure 4.6b, it is 13,900 lb. We disregard the positive or negative signs in reading the maximum values of the shear, for the diagrams are merely conventional methods of representing the absolute numerical values.

Another important fact to note is the point at which the shear changes from a plus to a minus quantity. We call this the point at which the shear passes through zero. In Figure 4.6a, it is under the 1000-lb load, 6 ft from  $R_1$ . In Figure 4.6b, it is under the 12,000-lb load, 10 ft from  $R_1$ . A major concern for noting this point is that it indicates the location of the maximum value of bending moment in the beam, as discussed in the next section.

#### Problems 4.3.A–F

For the beams shown in Figures 4.7a–f, draw the shear diagrams and note all critical values for shear. Note particularly the maximum value for shear and the point at which the shear passes through zero.

### 4.4 BENDING MOMENTS IN BEAMS

The forces that tend to cause bending in a beam are the reactions and the loads. Consider the section X-X, 6 ft from  $R_1$  (Figure 4.8). The force  $R_1$ ,

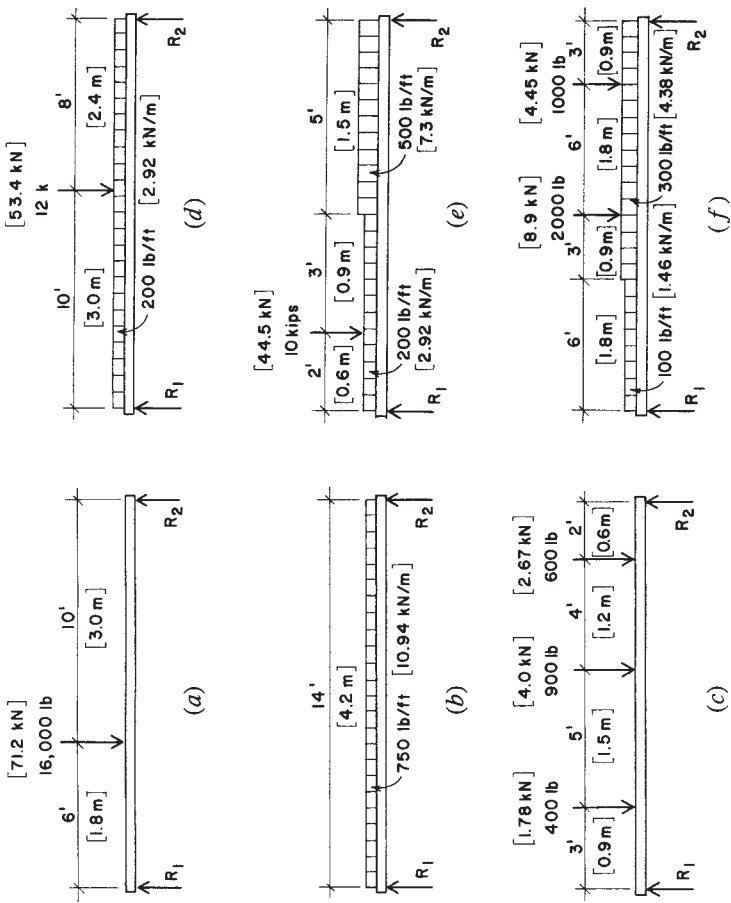
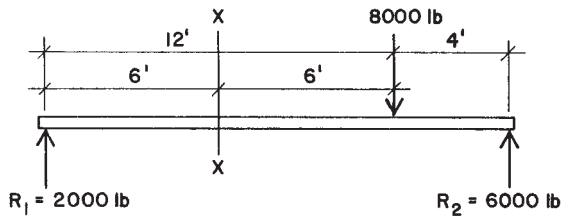


Figure 4.7 Problems 4.3.A–F.



**Figure 4.8** Development of bending at a selected cross section.

or 2000 lb, tends to cause a clockwise rotation about this point. Because the force is 2000 lb and the lever arm is 6 ft, the moment of the force is  $2000 \times 6 = 12,000$  ft-lb. This same value may be found by considering the forces to the right of the section X-X:  $R_2$ , which is 6000 lb, and the load 8000 lb, with lever arms of 10 and 6 ft, respectively. The moment of the reaction is  $6000 \times 10 = 60,000$  ft-lb, and its direction is counterclockwise with respect to the section X-X. The moment of force 8000 lb is  $8000 \times 6 = 48,000$  ft-lb, and its direction is clockwise. Then  $60,000$  ft-lb  $- 48,000$  ft-lb =  $12,000$  ft-lb, the resultant moment tending to cause counterclockwise rotation about the section X-X. This is the same magnitude as the moment of the forces on the left, which tends to cause a clockwise rotation.

Thus, it makes no difference whether use is made of the forces to the right of the section or the left, the magnitude of the moment is the same. It is called the *bending moment* (or the *internal bending moment*) because it is the moment of the forces that causes bending stresses in the beam. Its magnitude varies throughout the length of the beam. For instance, at 4 ft from  $R_1$ , it is only  $2000 \times 4$ , or 8000 ft-lb. The bending moment is the algebraic sum of the moments of the forces on either side of the section. For simplicity, take the forces on the left; then the bending moment at any section of a beam is equal to the moments of the reactions minus the moments of the loads to the left of the section. Because the bending moment is the result of multiplying forces by distances, the denominations are foot-pounds or kip-feet.

## Bending Moment Diagrams

The construction of bending moment diagrams follows the procedure used for shear diagrams. The beam span is drawn to scale showing the

locations of the loads. Below this, and usually below the shear diagram, a horizontal baseline is drawn representing zero bending moment. Then the bending moments are computed at various sections along the beam span, and the values are plotted vertically to any convenient scale. In simple beams, all bending moments are positive and therefore are plotted above the baseline. In overhanging or continuous beams, there are also negative moments, and these are plotted below the baseline.

**Example 3.** The load diagram in Figure 4.9 shows a simple beam with two concentrated loads. Draw the shear and bending moment diagrams.

*Solution:*  $R_1$  and  $R_2$  are computed first, and are found to be 16,000 lb and 14,000 lb, respectively. These values are recorded on the load diagram.

The shear diagram is drawn as described in Section 4.3. Note that, in this instance, it is only necessary to compute the shear at one section (between the concentrated loads) because there is no distributed load, and we know that the shear at the supports is equal in magnitude to the reactions.

Because the value of the bending moment at any section of the beam is equal to the moments of the reactions minus the moments of the loads to the left of the section, the moment at  $R_1$  must be zero, for there are no forces to the left. Other values in the length of the beam are computed as follows. The subscripts ( $x = 1$ , etc.) show the distance from  $R_1$  at which the bending moment is computed.

$$M_{(x=1)} = (16,000 \times 1) = 16,000 \text{ ft-lb}$$

$$M_{(x=2)} = (16,000 \times 2) = 32,000 \text{ ft-lb}$$

$$M_{(x=5)} = (16,000 \times 5) - (12,000 \times 3) = 44,000 \text{ ft-lb}$$

$$M_{(x=8)} = (16,000 \times 8) - (12,000 \times 6) = 56,000 \text{ ft-lb}$$

$$M_{(x=10)} = (16,000 \times 10) - \{(12,000 \times 8) + (18,000 \times 2)\} = 28,000 \text{ ft-lb}$$

$$M_{(x=12)} = (16,000 \times 12) - \{(12,000 \times 10) + (18,000 \times 4)\} = 0$$

The result of plotting these values is shown in the bending moment diagram of Figure 4.9. More moments were computed than were necessary. We know that the bending moments at the supports of simple beams are zero, and in this instance, only the bending moments directly under the loads were needed.

### Relations Between Shear and Bending Moment

In simple beams, the shear diagram passes through zero at some point between the supports. As stated earlier, an important principle in this respect is that the bending moment has a maximum magnitude wherever the shear passes through zero. In Figure 4.9, the shear passes through zero under the 18,000-lb load, that is, at  $x = 8$  ft. Note that the bending moment has its greatest value at this same point, 56,000 ft-lb.

**Example 4.** Draw the shear and bending moment diagrams for the beam shown in Figure 4.10, which carries a uniformly distributed load of 400 lb/ft and a concentrated load of 21,000 lb located 4 ft from  $R_1$ .

*Solution:* Computing the reactions, we find  $R_1 = 17,800$  lb and  $R_2 = 8800$  lb. By use of the process described in Section 4.3, the critical shear values are determined and the shear diagram is drawn as shown in the figure.

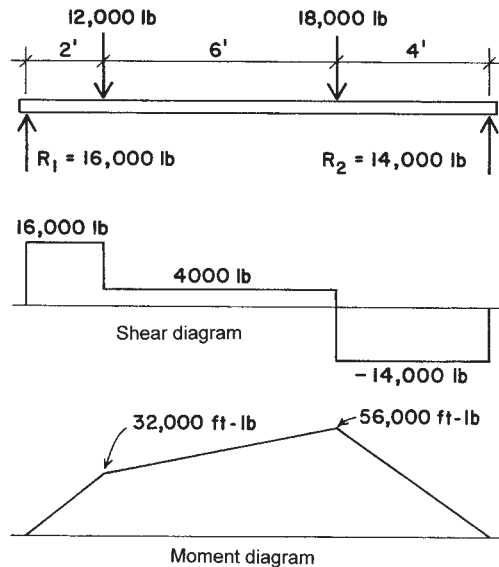


Figure 4.9 Example 3.



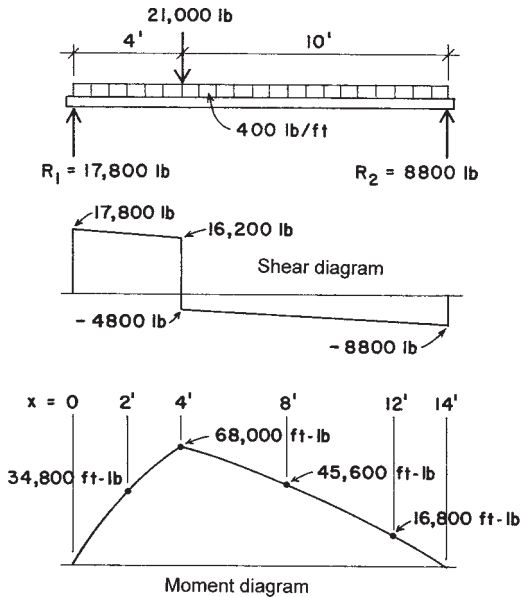


Figure 4.10 Example 4.

Although the only value of bending moment that must be computed is that where the shear passes through zero, some additional values are determined in order to plot the true form of the moment diagram. Thus,

$$M_{(x=2)} = (17,800 \times 2) - (400 \times 2 \times 1) = 34,800 \text{ ft-lb}$$

$$M_{(x=4)} = (17,800 \times 4) - (400 \times 4 \times 2) = 68,000 \text{ ft-lb}$$

$$M_{(x=8)} = (17,800 \times 8) - \{(400 \times 8 \times 4) + (21,000 \times 4)\} = 45,600 \text{ ft-lb}$$

$$M_{(x=12)} = (17,800 \times 12) - \{(400 \times 12 \times 6) + (21,000 \times 8)\} = 16,800 \text{ ft-lb}$$

From the two preceding examples (Figures 4.9 and 4.10), it will be observed that the shear diagram for the parts of the beam on which no loads occur is represented by horizontal lines. For the parts of the beam on which a uniformly distributed load occurs, the shear diagram consists of straight inclined lines. The bending moment diagram is represented by straight inclined lines when only concentrated loads occur, and by a curved line if the load is distributed.

Occasionally, when a beam has both concentrated and uniformly distributed loads, the shear does not pass through zero under one of the concentrated loads. This frequently occurs when the distributed load is relatively large compared with the concentrated loads. Since it is necessary in designing beams to find the maximum bending moment, we must know the point at which it occurs. This, of course, is the point where the shear passes through zero, and its location is readily determined by the procedure illustrated in the following example.

**Example 5.** The load diagram in Figure 4.11 shows a beam with a concentrated load of 7000 lb, applied 4 ft from the left reaction, and a uniformly distributed load of 800 lb/ft extending over the full span. Compute the maximum bending moment on the beam.

**Solution:** The values of the reactions are found to be  $R_1 = 10,600$  lb and  $R_2 = 7600$  lb and are recorded on the load diagram.

The shear diagram is constructed, and it is observed that the shear passes through zero at some point between the concentrated load of 7000 lb and the right reaction. Call this distance  $x$  ft from  $R_2$ . The value of the shear at this section is zero; therefore, an expression for the shear for this point, using the reaction and loads, is equal to zero. This equation contains the distance  $x$ :

$$V_{(\text{at } x)} = -7600 + 800x = 0, \quad x = \frac{7600}{800} = 9.5 \text{ ft}$$

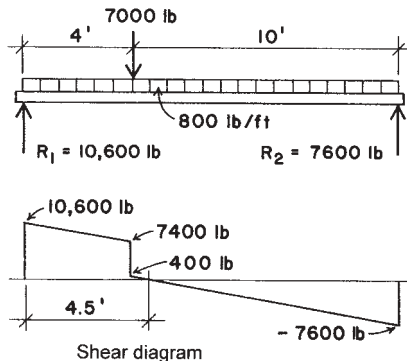


Figure 4.11 Example 5.

The zero shear point is thus at 9.5 ft from the right support and (as shown in the diagram) at 4.5 ft from the left support. This location can also be determined by writing an equation for the summation of shear from the left of the point, which should produce the answer of 4.5 ft.

Following the convention of summing up the moments from the left of the section, the maximum moment is determined as

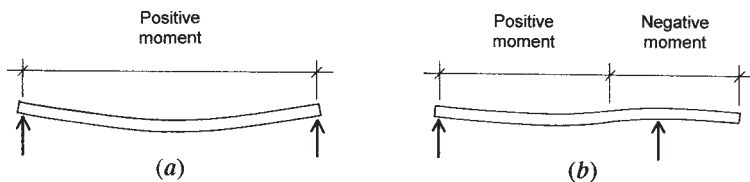
$$M_{(x=4.5)} = +(10,600 \times 4.5) - (7000 \times 0.5) - \left(800 \times 4.5 \times \frac{4.5}{2}\right) = 36,100 \text{ ft-lb}$$

### Problems 4.4.A–F

Draw the shear and bending moment diagrams for the beams in Figure 4.7, indicating all critical values for shear and moment and all significant dimensions. (*Note:* These are the beams for Problem 4.3, for which the shear diagrams were constructed.)

## 4.5 SENSE OF BENDING IN BEAMS

When a simple beam bends, it has a tendency to assume the shape shown in Figure 4.12*a*. In this case, the fibers in the upper part of the beam are in compression. For this condition, the bending moment is considered as positive. Another way to describe a positive bending moment is to say that it is positive when the curve assumed by the bent beam is concave upward. When a beam projects beyond a support (Figure 4.12*b*), this portion of the beam has tensile stresses in the upper part. The bending moment for this condition is called negative; the beam is bent concave downward. When constructing moment diagrams, following the method previously described, the positive and negative moments are shown graphically.



**Figure 4.12** Sign of internal bending moment; bending stress convention.

**Example 6.** Draw the shear and bending moment diagrams for the overhanging beam shown in Figure 4.13.

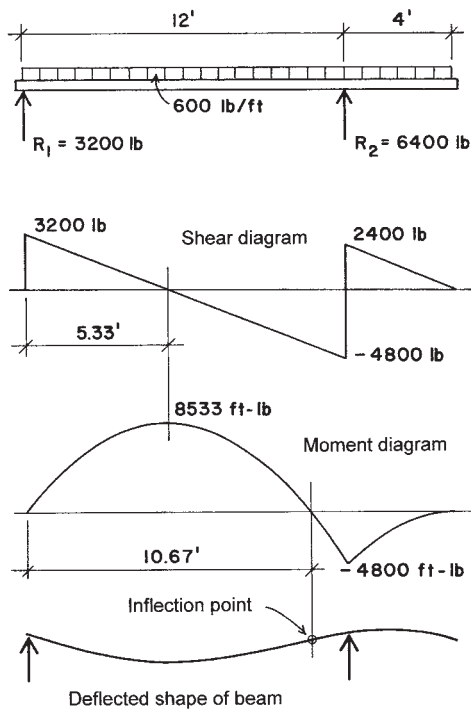
*Solution:* Computing the reactions

$$\text{From } \Sigma M \text{ about } R_1: R_2 \times 12 = 600 \times 16 \times 8, \quad R_2 = 6400 \text{ lb}$$

$$\text{From } \Sigma M \text{ about } R_2: R_1 \times 12 = 600 \times 16 \times 4, \quad R_1 = 3200 \text{ lb}$$

With the reactions determined, the construction of the shear diagram is quite evident. For the location of the point of zero shear, considering its distance from the left support as  $x$ ,

$$3200 - 600x = 0, \quad x = 5.33 \text{ ft}$$



**Figure 4.13** Example 6.

For the critical values needed to plot the moment diagram:

$$M_{(x=5.33)} = +(3200 \times 5.33) - \left( 600 \times 5.33 \times \frac{5.33}{2} \right) = 8533 \text{ ft-lb}$$

$$M_{(x=12)} = (3200 \times 12) - (600 \times 12 \times 6) = -4800 \text{ ft-lb}$$

The form of the moment diagram for the distributed loading is a curve (parabolic), which may be verified by plotting some additional points on the graph.

For this case, the shear diagram passes through zero twice, both of which points indicate peaks of the moment diagram—one positive and one negative. As the peak in the positive portion of the moment diagram is actually the apex of the parabola, the location of the zero moment value is simply twice the value previously determined as  $x$ . This point corresponds to the change in the form of curvature on the elastic curve (deflected shape) of the beam; this point is described as the *inflection point* for the deflected shape. The location of the point of zero moment can also be determined by writing an equation for the sum of moments at the unknown location. In this case, calling the new unknown point  $x$ ,

$$M = 0 = +(3200 \times x) - \left( 600 \times x \times \frac{x}{2} \right)$$

Solution of this quadratic equation should produce the value of  $x = 10.67$  ft.

**Example 7.** Compute the maximum bending moment for the overhanging beam shown in Figure 4.14.

*Solution:* Computing the reactions gives  $R_1 = 3200$  lb and  $R_2 = 2800$  lb. As usual, the shear diagram can now be plotted as the graph of the loads and reactions, proceeding from left to right. Note that the shear passes through zero at the location of the 4000-lb load and at both supports. As usual, these are clues to the form of the moment diagram.

With the usual moment summations, values for the moment diagram can now be found at the locations of the supports and all of the concentrated loads. From this plot, it will be noted that there are two inflection points (locations of zero moment). As the moment diagram is composed of straight-line segments in this case, the locations of these points may be

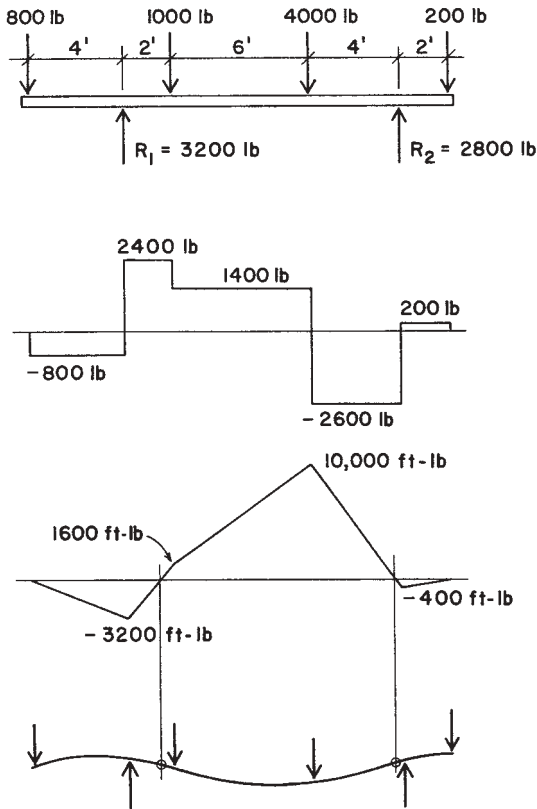


Figure 4.14 Example 7.

found by writing simple linear equations for their locations. However, use can also be made of some relationships between the shear and moment graphs. One of these has already been used, relating to the correlation of zero shear and maximum moment. Another relationship is that the change of the value of moment between any two points along the beam is equal to the total area of the shear diagram between the points. If the value of moment is known at some point, it is thus a simple matter to find values at other points. For example, starting from the left end, the value of moment is known to be zero at the left end of the beam; then the value of the moment at the support is the area of the rectangle on the shear

diagram with base of 4 ft and height of 800 lb—the area being  $4 \times 800 = 3200$  ft-lb.

Now, proceeding along the beam to the point of zero moment (call it  $x$  distance from the support), the change is again 3200, which relates to an area of the shear diagram that is  $x \times 2400$ . Thus,

$$2400x = 3200, \quad x = \frac{3200}{2400} = 1.33 \text{ ft}$$

And now, calling the distance from the right support to the point of zero moment  $x$ ,

$$2600x = 400, \quad x = \frac{400}{2600} = 0.154 \text{ ft}$$

#### ***Problems 4.5.A–D***

Draw the shear and bending moment diagrams for the beams in Figure 4.15, indicating all critical values for shear and moment and all significant dimensions.

## **4.6 CANTILEVER BEAMS**

In order to keep the signs for shear and moment consistent with those for other beams, it is convenient to draw a cantilever beam with its fixed end to the right, as shown in Figure 4.16. We then plot the values for the shear and moment on the diagrams as before, proceeding from the left end.

***Example 8.*** The cantilever beam shown in Figure 4.16a projects 12 ft from the face of the wall and has a concentrated load of 800 lb at the unsupported end. Draw the shear and moment diagrams. What are the values of the maximum shear and maximum bending moment?

***Solution:*** The value of the shear is  $-800$  lb throughout the entire length of the beam. The bending moment is maximum at the wall; its value is  $800 \times 12 = -9600$  ft-lb. The shear and moment diagrams are as shown in Figure 4.16a. Note that the moment is all negative for the cantilever beam, corresponding to its concave downward shape throughout its length.

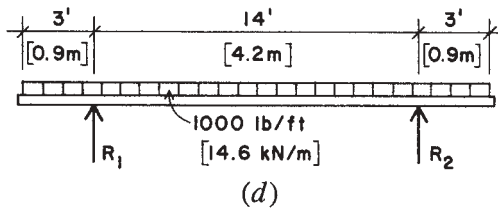
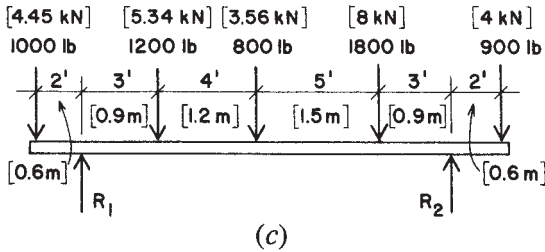
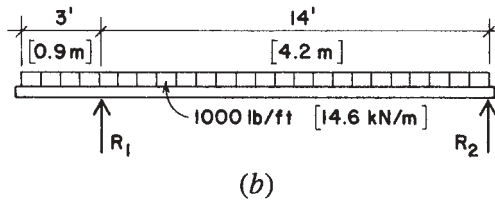
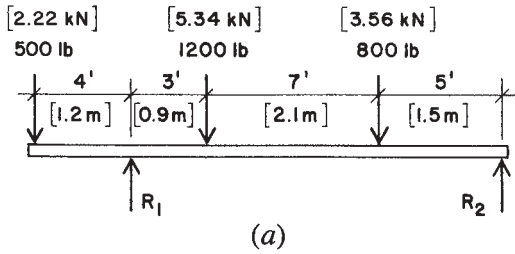


Figure 4.15 Problems 4.5.A–D.



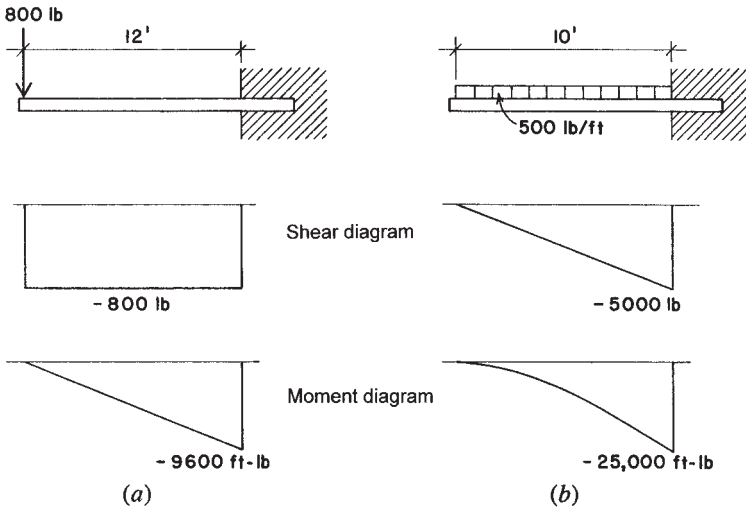


Figure 4.16 Examples 8 and 9.

Although they are not shown in the figure, the reactions in this case are a combination of an upward force of 800 lb and a clockwise resisting moment of 9600 ft-lb.

**Example 9.** Draw the shear and bending moment diagrams for the cantilever beam shown in Figure 4.16b, which carries a uniformly distributed load of 500 lb/ft over its full length.

*Solution:* The total load is  $500 \times 10 = 5000$  lb. The reactions are an upward force of 5000 lb and a moment determined as

$$M = -500 \times 10 \times \frac{10}{2} = -25,000 \text{ ft-lb}$$

which—it may be noted—is also the total area of the shear diagram between the outer end and the support.

**Example 10.** The cantilever beam indicated in Figure 4.17 has a concentrated load of 2000 lb and a uniformly distributed load of 600 lb/ft at the positions shown. Draw the shear and bending moment diagrams.

What are the magnitudes of the maximum shear and maximum bending moment?

*Solution:* The reactions are actually *equal* to the maximum shear and bending moment. Determined directly from the forces, they are

$$V = 2000 + (600 \times 6) = 5600 \text{ lb}$$

$$M = -(2000 \times 14) - \left( 600 \times 6 \times \frac{6}{2} \right) = -38,800 \text{ ft-lb}$$

The diagrams are quite easily determined. The other moment value needed for the moment diagram can be obtained from the moment of the concentrated load or from the simple rectangle of the shear diagram:  $2000 \times 8 = 16,000 \text{ ft-lb}$ .

Note that the moment diagram has a straight-line shape from the outer end to the beginning of the distributed load, and becomes a curve from this point to the support.

It is suggested that Example 10 be reworked with Figure 4.17 reversed, left for right. All numerical results will be the same, but the shear diagram will be positive over its full length.

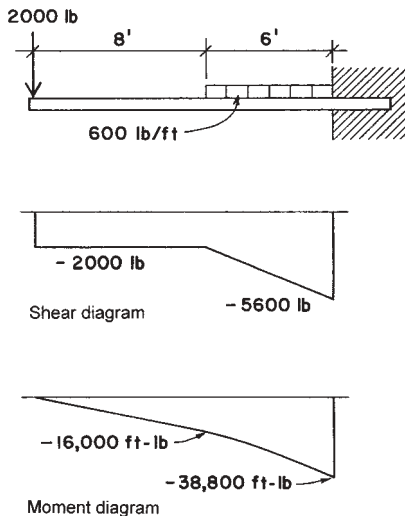


Figure 4.17 Example 10.

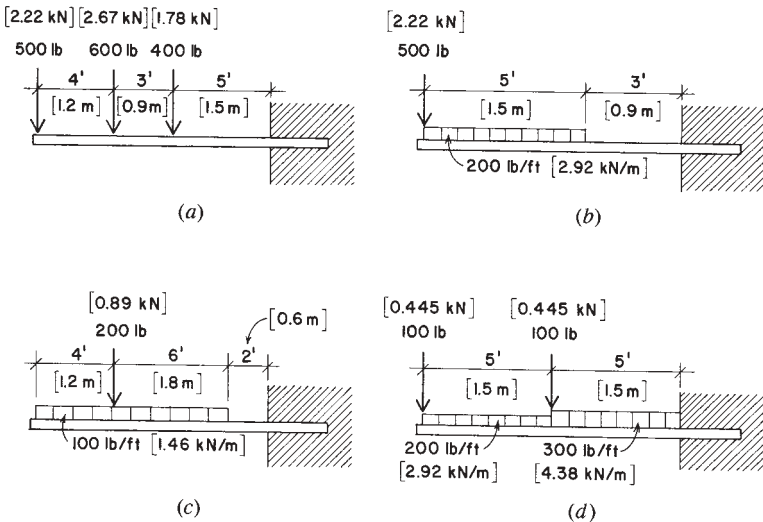
**Problems 4.6.A–D**

Draw the shear and bending moment diagrams for the beams in Figure 4.18, indicating all critical values for shear and moment and all significant dimensions.

**4.7 TABULATED VALUES FOR BEAM BEHAVIOR**

**Bending Moment Formulas**

The methods of computing beam reactions, shears, and bending moments presented thus far in this chapter make it possible to find critical values for design under a wide variety of loading conditions. However, certain conditions occur so frequently that it is convenient to use formulas that give the maximum values directly. Structural design handbooks contain many such formulas; two of the most commonly used formulas are derived in the following examples.



**Figure 4.18** Problems 4.6.A–D.

### Simple Beam, Concentrated Load at Center of Span

A simple beam with a concentrated load at the center of the span occurs very frequently in practice. Call the load  $P$  and the span length between supports  $L$ , as indicated in the load diagram of Figure 4.19a. For this symmetrical loading, each reaction is  $P/2$ , and it is readily apparent that the shear will pass through zero at distance  $x = L/2$  from  $R_1$ . Therefore, the maximum bending moment occurs at the center of the span, under the load. Computing the value of the bending moment at this section,

$$M = \frac{P}{2} \times \frac{L}{2} = \frac{PL}{4}$$

**Example 11.** A simple beam 20 ft in length has a concentrated load of 8000 lb at the center of the span. Compute the maximum bending moment.

*Solution:* As just derived, the formula giving the value of the maximum bending moment for this condition is  $M = PL/4$ . Therefore,

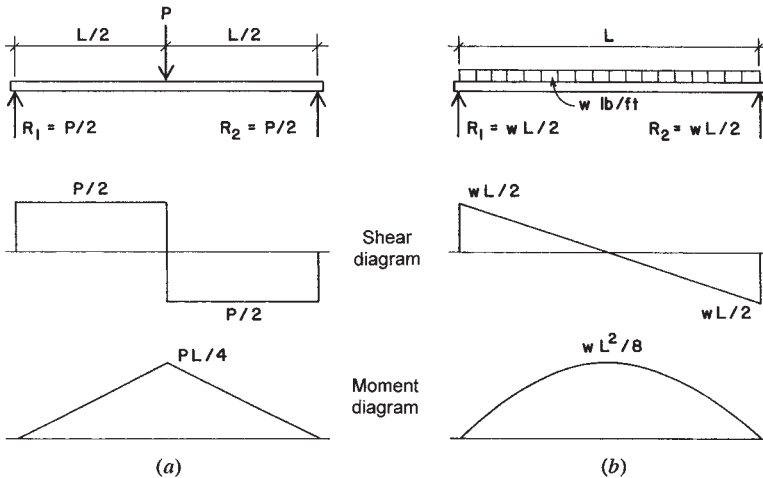
$$M = \frac{PL}{4} = \frac{8000 \times 20}{4} = 40,000 \text{ ft-lb}$$

### Simple Beam, Uniformly Distributed Load

This is probably the most common beam loading; it occurs time and again. For any beam, its own dead weight as a load to be carried is usually of this form. Call the span  $L$  and the unit load  $w$ , as indicated in Figure 4.19b. The total load on the beam is  $W = wL$ ; hence each reaction is  $W/2$  or  $wL/2$ . The maximum bending moment occurs at the center of the span at distance  $L/2$  from  $R_1$ . Writing the value of  $M$  for this section,

$$M = +\left(\frac{wL}{2} \times \frac{L}{2}\right) - \left(w \times \frac{L}{2} \times \frac{L}{4}\right) = \frac{wL^2}{8}, \quad \text{or } \frac{WL}{8}$$

Note the alternative use of the unit load  $w$  or the total load  $W$  in this formula. Both forms will be seen in various references. It is important to carefully identify the use of one or the other.



**Figure 4.19** Loading and internal force diagrams for simple beams.

**Example 12.** A simple beam 14 ft long has a uniformly distributed load of 800 lb/ft. Compute the maximum bending moment.

*Solution:* As just derived, the formula that gives the maximum bending moment for a simple beam with uniformly distributed load is  $M = wL^2/8$ . Substituting these values,

$$M = \frac{wL^2}{8} = \frac{800 \times 14^2}{8} = 19,600 \text{ ft-lb}$$

or, using the total load of  $800 \times 14 = 11,200$  lb,

$$M = \frac{WL}{8} = \frac{11,200 \times 14}{8} = 19,600 \text{ ft-lb}$$

### Use of Tabulated Values for Beams

Some of the most common beam loadings are shown in Figure 4.20. In addition to the formulas for the reactions  $R$ , for maximum shear  $V$ , and for maximum bending moment  $M$ , expressions for maximum deflection

$D$  (or  $\Delta$ ) are given also. Deflections formulas are not discussed in this chapter, but are considered in Chapter 11.

In Figure 4.20, if the loads  $P$  and  $W$  are in pounds or kips, the vertical shear  $V$  will also be in units of pounds or kips. When the loads are given in pounds or kips and the span in feet, the bending moment  $M$  will be in units of foot-pounds or kip-feet.

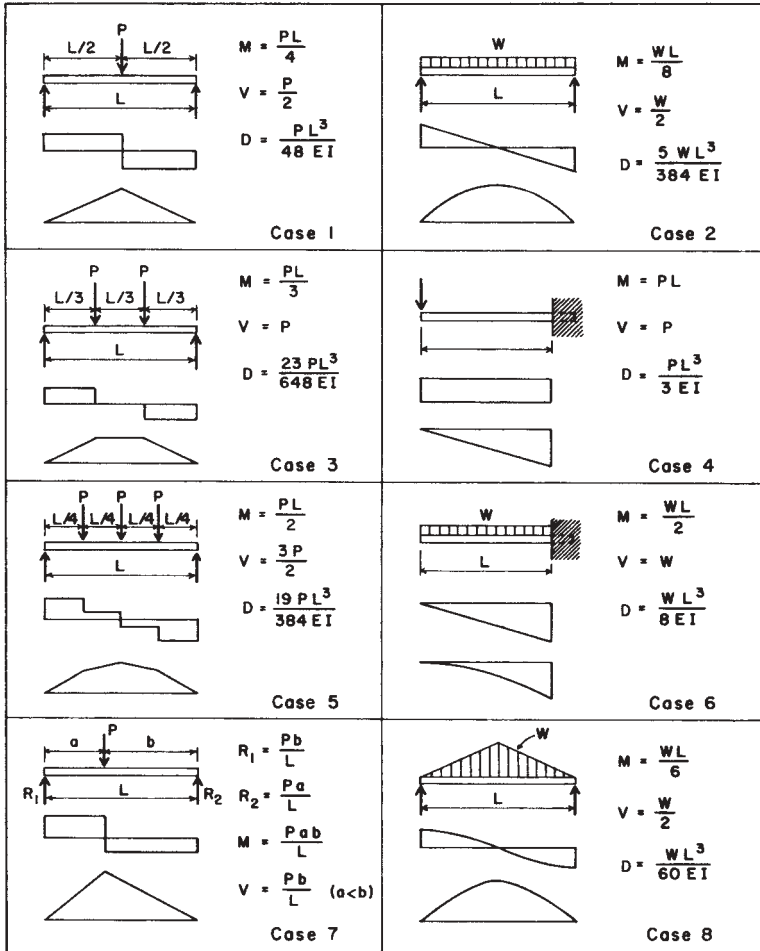


Figure 4.20 Values and diagrams for typical beam loadings.

***Problem 4.7.A***

A simple-span beam has two concentrated loads of 4 kips [17.8 kN], each placed at the third points of the 24-ft [7.32-m] span. Find the value for the maximum bending moment in the beam.

***Problem 4.7.B***

A simple-span beam has a uniformly distributed load of 2.5 kips/ft [36.5 kN/m] on a span of 18 ft [5.49 m]. Find the value for the maximum bending moment in the beam.

***Problem 4.7.C***

A simple beam with a span of 32 ft [9.745 m] has a concentrated load of 12 kips [53.4 kN] at 12 ft [3.66 m] from one end. Find the value for the maximum bending moment in the beam.

***Problem 4.7.D***

A simple beam with a span of 36 ft [10.97 m] has a distributed load that varies from a value of 0 at its ends to a maximum of 1000 lb/ft [14.59 kN/m] at its center (Case 8 in Figure 4.20). Find the value for the maximum bending moment in the beam.

# 5

---

## CONTINUOUS AND RESTRAINED BEAMS

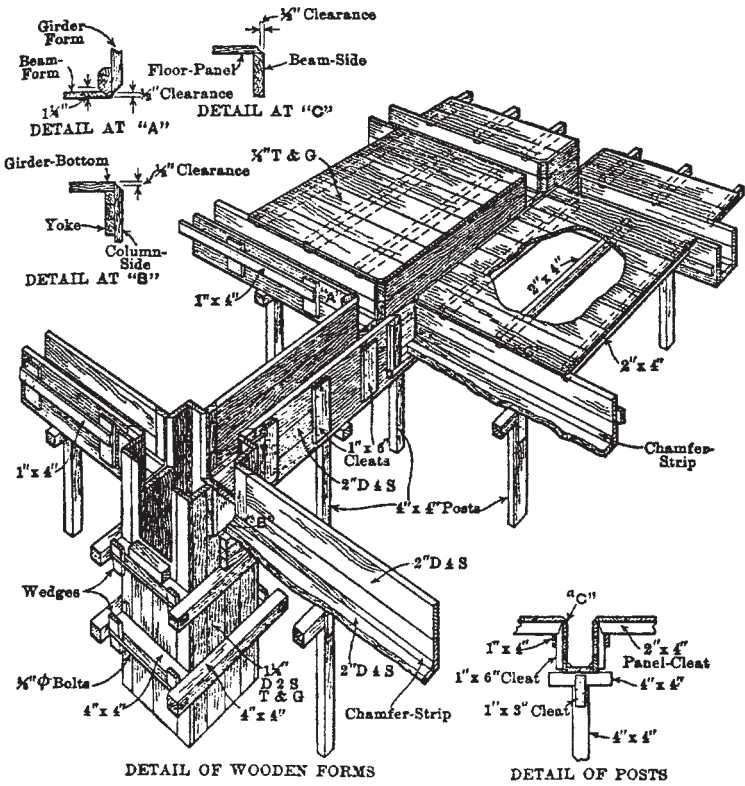
---

Beams were used in combination with vertical posts in ancient cultures to produce early framed structures, and this type of structure continues to be used today. In some forms of modern construction, however, a new factor is the development of continuous members, consisting of multiple-span beams and multistory columns (see Figure 5.1). In these forms of construction, beams are continuous through adjacent spans and sometimes are restrained at their ends by rigid attachment to columns. This chapter presents some basic considerations for continuity and end restraint for beams.

### 5.1 BENDING MOMENTS FOR CONTINUOUS BEAMS

It is beyond the scope of this book to give a detailed discussion of bending in members continuous over supports, but the material presented in this section will serve as an introduction to the subject. A *continuous beam* is a beam that rests on more than two supports. Continuous beams

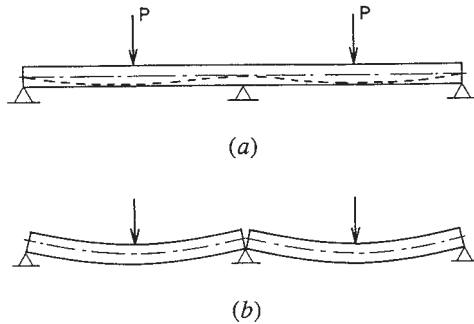




**Figure 5.1** Elaborate wood construction for forming of a sitecast concrete slab and beam structure supported by concrete columns. Reproduced from *Architects and Builders Handbook*, by H. Parker and F. Kidder, 1931, with permission of the publisher, John Wiley & Sons, New York. The continuously cast concrete structure introduced a degree of structural continuity not formerly experienced with ordinary wood and steel constructions, necessitating more complex investigations for structural behaviors to support design work.

are characteristic of sitecast concrete construction, but occur less often in wood and steel construction.

The concepts underlying continuity and bending under restraint are illustrated in Figure 5.2. Figure 5.2a represents a single beam resting on three supports and carrying equal loads at the centers of the two spans. If the beam is cut over the middle support, as shown in Figure 5.2b, the



**Figure 5.2** Deflected shape of the two-span beam. (a) As a single-piece, two-span member. (b) With two separate pieces.

result will be two simple beams. Each of these simple beams will deflect as shown. However, when the beam is made continuous over the middle support, its deflected form is as indicated in Figure 5.2a.

It is evident that there is no bending moment developed over the middle support in Figure 5.2b, while there must be a moment over the support in Figure 5.2a. In both cases, there is positive moment at the midspan; that is, there is tension in the bottom and compression in the top of the beam at these locations. In the continuous beam, however, there is a negative moment over the middle support; that is, there is tension in the top and compression in the bottom of the beam. The effect of the negative moment over the support is to reduce the magnitudes of both maximum bending moment and deflection at midspan, which is a principal advantage of continuity.

Values for reaction forces and bending moments cannot be found for continuous beams by use of the equations for static equilibrium alone. For example, the beam in Figure 5.2a has three unknown reaction forces, which constitute a parallel force system with the loads. For this condition, there are only two conditions of equilibrium, and thus only two available equations for solving for the three unknowns. This presents a situation in algebra that is qualified as *indeterminate*, and the structure so qualified is said to be *statically indeterminate*.

Solutions for investigation of indeterminate structures require additional conditions to supplement those available from simple statics. These additional conditions are derived from the deformation and the stress mechanisms of the structure. Various methods for investigation of

indeterminate structures have been developed. Of particular interest now are those that yield to application to computer-aided processes. Just about any structure, with any degree of indeterminacy, can now be investigated with readily available programs.

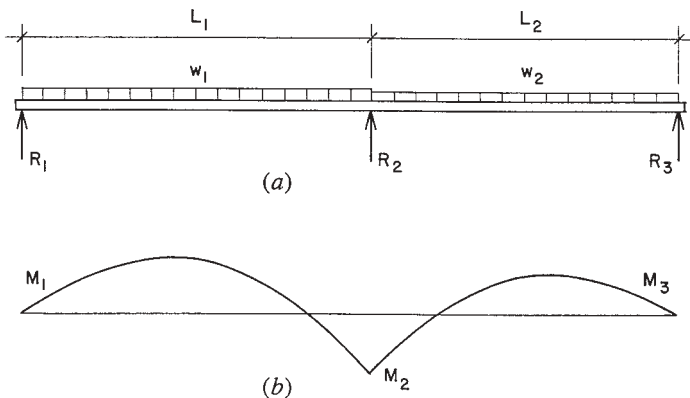
A procedural problem with highly indeterminate structures is that something about the structure must be determined before an investigation can be performed. Useful for this purpose are shortcut methods that give reasonably approximate answers without an extensive investigation.

### Theorem of Three Moments

One method for determining reactions and constructing the shear and bending moment diagrams for continuous beams is based on the *theorem of three moments*. This theorem deals with the relation among the bending moments at any three consecutive supports of a continuous beam. Application of the theorem produces an equation, called the *three-moment equation*. The three-moment equation for a continuous beam of two spans with uniformly distributed loading and constant moment of inertia is

$$M_1 L_1 + 2M_2(L_1 + L_2) + M_3 L_2 = -\frac{w_1 L_1^3}{4} - \frac{w_2 L_2^3}{4}$$

in which the various terms are as shown in Figure 5.3. The following examples demonstrate the use of this equation.



**Figure 5.3** Diagrams for the two-span beam with uniform load.

### Continuous Beam with Two Equal Spans

This is the simplest case with the formula reduced by the symmetry plus the elimination of  $M_1$  and  $M_2$  due to the discontinuity of the beam at its outer ends. The equation is reduced to

$$4M_2 = -\frac{wL^3}{2}$$

With the loads and spans as given data, a solution for this case is reduced to solving for  $M_2$ , the negative moment at the center support. Transforming the equation produces a form for direct solution of the unknown moment; thus,

$$M_2 = -\frac{wL^2}{8}$$

With this moment determined, it is possible to now use the available conditions of statics to solve the rest of the data for the beam. The following example demonstrates the process.

**Example 1.** Compute the values for the reactions and construct the shear and moment diagrams for the beam shown in Figure 5.4a.

*Solution:* With only two conditions of statics for the parallel force system, it is not possible to solve directly for the three unknown reactions. However, use of the equation for the moment at the middle support yields a condition that can be used as shown in the following work.

$$M_2 = -\frac{wL^2}{8} = -\frac{(100)(10)^2}{8} = -1250 \text{ ft-lb}$$

Next, an equation for the bending moment at 10 ft to the right of the left support is written in the usual manner, and is equated to the now known value of 1250 ft-lb.

$$M_{(x=10)} = (R_1 \times 10) - (100 \times 10 \times 5) = -1250 \text{ ft-lb}$$

from which

$$10R_1 = 3750, \quad R_1 = 375 \text{ lb}$$

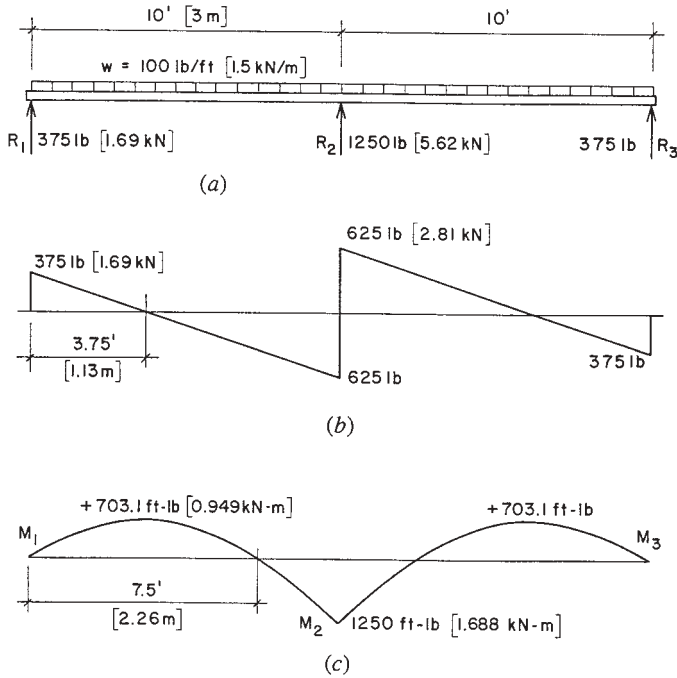


Figure 5.4 Example 1.

By symmetry, this is also the value for  $R_3$ . The value for  $R_2$  can then be found by a summation of vertical forces; thus,

$$\Sigma F_V = 0 = (375 + 375 + R_2) - (100 \times 20), \quad R_2 = 1250 \text{ lb}$$

Sufficient data have now been determined to permit the complete construction of the shear diagram, as shown in Figure 5.4*b*. The location of zero shear is determined by the equation for shear at the unknown distance  $x$  from the left support:

$$375 - (100 \times x) = 0, \quad x = 3.75 \text{ ft}$$

The maximum value for positive moment at this location can be determined with a moment summation or by finding the area of the shear diagram between the end and the zero shear location:

$$M = \frac{375 \times 3.75}{2} = 703.125 \text{ ft-lb}$$

Because of symmetry, the location of zero moment is determined as twice the distance of the zero shear point from the left support. Sufficient data are now available to plot the moment diagram as shown in Figure 5.4c.

### **Problems 5.1.A, B**

Using the three-moment equation, find the bending moments and reactions and draw the complete shear and moment diagrams for the following beams that are continuous over two equal spans and carry uniformly distributed loadings.

Beam	Span Length, ft	Load, lb/ft
A	16	200
B	24	350

### **Continuous Beam with Unequal Spans**

The following example shows the slightly more complex problem of dealing with unequal spans.

**Example 2.** Construct the shear and moment diagrams for the beam in Figure 5.5a.

*Solution:* In this case, the moments at the outer supports are again zero, which reduces the task to solving for only one unknown. Applying the given values to the equation,

$$2M_2(14 + 10) = -\frac{1000 \times 14^3}{4} - \frac{1000 \times 10^3}{4}$$

$$M_2 = -19,500 \text{ ft-lb}$$

Writing a moment summation about a point 14 ft to the right of the left end support, using the forces to the left of the point,

$$14R_1 - (1000 \times 14 \times 7) = -19,500, \quad R_1 = 5607 \text{ lb}$$

Then writing an equation about a point 10 ft to the *left* of the right end, using the forces to the *right* of the point,

$$10R_3 - (1000 \times 10 \times 5) = -19,500, \quad R_3 = 3050 \text{ lb}$$

A vertical force summation will yield the value of  $R_2 = 15,343 \text{ lb}$ . With the three reactions determined, the shear values for completing the shear diagram are known. Determination of the points of zero shear and zero moment and the values for positive moment in the two spans can be done as demonstrated in Exercise 1. The completed diagrams are shown in Figures 5.5*b* and *c*.

### Problems 5.1.C, D

Find the reactions and draw the complete shear and moment diagrams for the following continuous beams with two unequal spans and uniformly distributed loading.

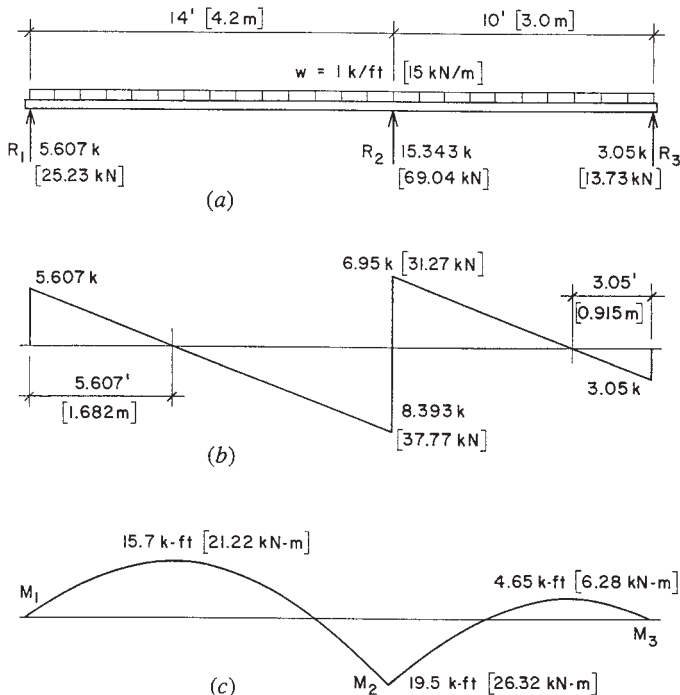


Figure 5.5 Example 2.

Beam	First Span, ft	Second Span, ft	Load, lb/ft
C	12	16	2000
D	16	20	1200

**Continuous Beam with Concentrated Loads**

In the previous examples, the loads were uniformly distributed. Figure 5.6a shows a two-span beam with a single concentrated load in each span. The shape for the moment diagram for this beam is shown in Figure 5.6b. For these conditions, the form of the three-moment equation is

$$M_1 L_1 + 2M_2 (L_1 + L_2) + M_3 L_2 = -P_1 L_1^2 [n_1 (1 - n_1)(1 + n_1)] - P_2 L_2^2 [n_2 (1 - n_2)(2 - n_2)]$$

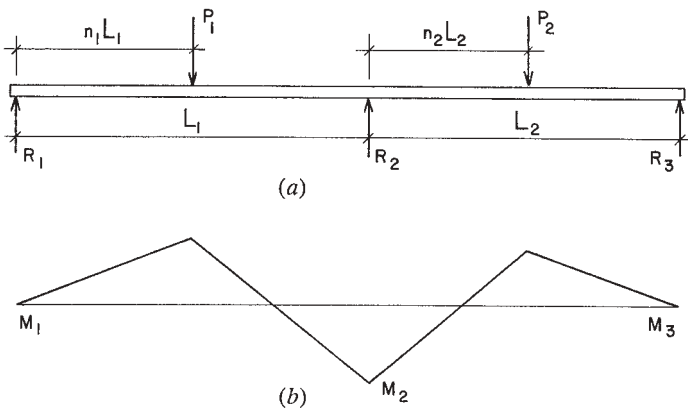
in which the various terms are as shown in Figure 5.6.

**Example 3.** Compute the reactions and construct the shear and moment diagrams for the beam in Figure 5.7a.

*Solution:* For this case, note that  $L_1 = L_2$ ,  $P_1 = P_2$ ,  $M_1 = M_3 = 0$ , and both  $n_1$  and  $n_2 = 0.5$ . Substituting these conditions and given data into the equation,

$$2M_2 (20 + 20) = -4000(20^2)(0.5 \times 0.5 \times 1.5) - 4000(20^2)(0.5 \times 0.5 \times 1.5)$$

from which  $M_2 = 15,000$  ft-lb.



**Figure 5.6** Diagrams for the two-span beam with concentrated loads.



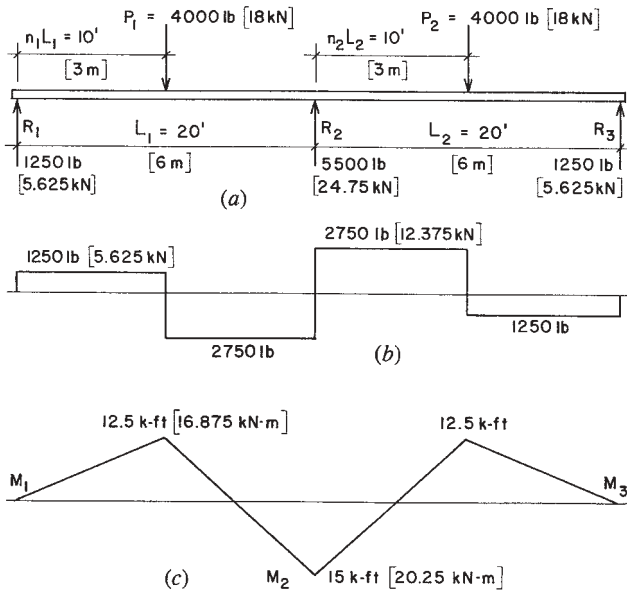


Figure 5.7 Example 3.

The value of moment at the middle support can now be used as in the previous examples to find the end reaction, from which it is determined that the value is 1250 lb. Then a summation of vertical forces will determine the value of  $R_2$  to be 5500 lb. This is sufficient data for construction of the shear diagram. Note that points of zero shear are evident on the diagram.

The values for maximum positive moment can be determined from moment summations at the sections or simply from the areas of the rectangles in the shear diagrams. The locations of points of zero moment can be found by simple proportion, since the moment diagram is composed of straight lines.

**Problems 5.1.E, F**

Find the reactions and draw the complete shear and moment diagrams for the following continuous beams with two equal spans and a single concentrated load at the center of each span.

Beam	Span Length, ft	Load, kips
E	24	3.0
F	32	2.4

### Continuous Beam with Three Spans

The preceding examples demonstrate that the key operation in investigation of continuous beams is the determination of negative moment values at the supports. Use of the three-moment equation has been demonstrated for a two-span beam, but the method may be applied to any two adjacent spans of a beam with multiple spans. For example, when applied to the three-span beam shown in Figure 5.8*a*, it would first be applied to the left span and the middle span, and next to the middle span and right span. This would produce two equations involving the two unknowns: the negative moments at the two interior supports. In this example case, the process would be simplified by the symmetry of the beam, but the application is a general one, applicable to any arrangement of spans and loads.

As with simple beams and cantilevers, common situations of spans and loading may be investigated and formulas for beam behavior values derived for subsequent application in simpler investigation processes. Thus, the values of reactions, shears, and moments displayed for the beam in Figure 5.8 may be used for any such support and loading conditions. Tabulations for many ordinary situations are available from various references.

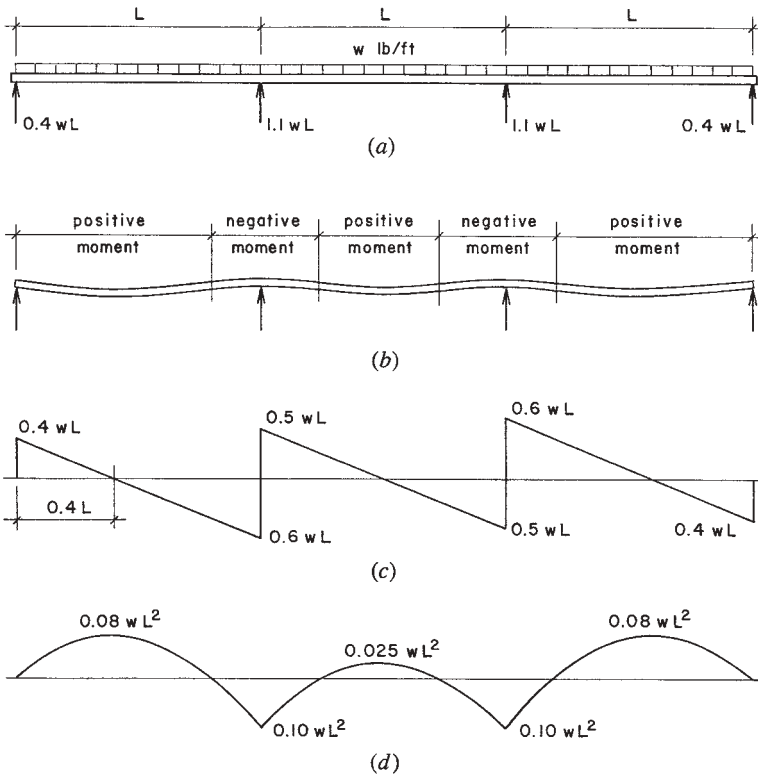
**Example 4.** A continuous beam has three equal spans of 20 ft [6 m] each and a uniformly distributed load of 800 lb/ft [12 kN/m] extending over the entire length of the beam. Compute the maximum bending moment and the maximum shear.

*Solution:* Referring to Figure 5.8*d*, the maximum positive moment ( $0.08wL^2$ ) occurs near the middle of each end span, and the maximum negative moment ( $0.10wL^2$ ) occurs over each of the interior supports. Using the larger value, the maximum bending moment on the beam is

$$\begin{aligned} M &= -0.10wL^2 = -(0.10 \times 800 \times 20 \times 20) \\ &= -32,000 \text{ ft}\cdot\text{lb} [43.2 \text{ kN}\cdot\text{m}] \end{aligned}$$

Figure 5.8*c* shows that the maximum shear occurs at the face of the first interior support and is

$$V = 0.6wL = (0.6 \times 800 \times 20) = 9600 \text{ lb} [43.2 \text{ kN}]$$



**Figure 5.8** Diagrams and values for the three-span beam with uniform load.

Using this process, it is possible to find the values of the reactions and then to construct the complete shear and moment diagrams, if the work at hand warrants it.

**Problem 5.1.G, H**

For the following continuous beams with three equal spans and uniformly distributed loading, find the reactions and draw the complete shear and moment diagrams.

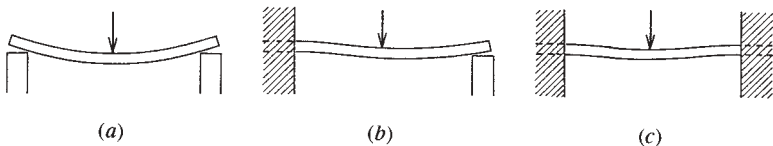
Beam	Span Length, ft	Load, lb/ft
G	24	1000
H	32	1600

## 5.2 RESTRAINED BEAMS

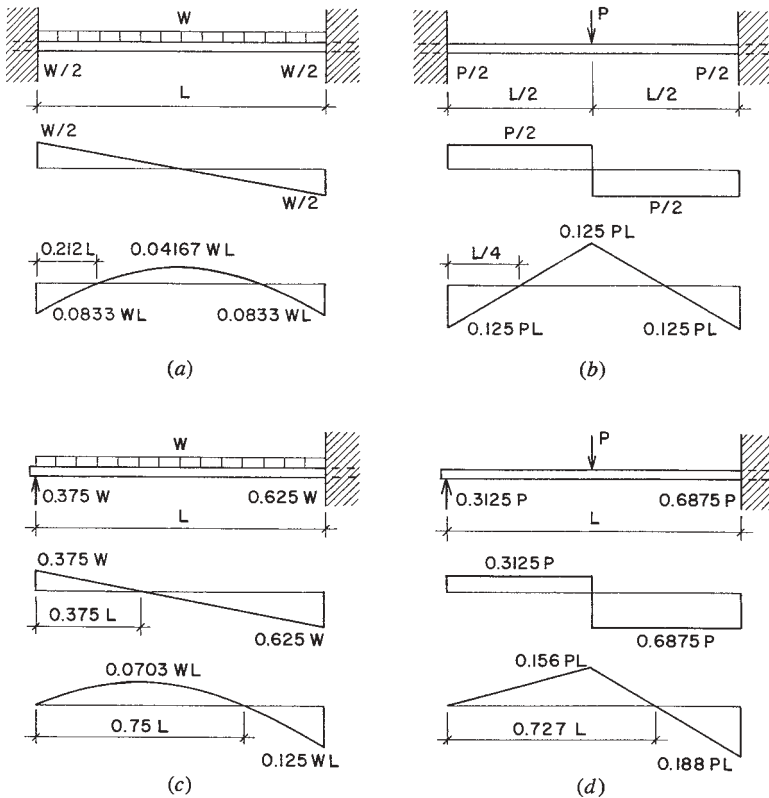
A simple beam was previously defined as a beam that rests on a support at each end, there being no restraint against bending at the supports; the ends are *simply supported*. The shape a simple beam tends to assume under load is shown in Figure 5.9a. Figure 5.9b shows a beam whose left end is *restrained* or *fixed*; meaning that free rotation of the beam end is prevented. Figure 5.9c shows a beam with both ends restrained. End restraint has an effect similar to that caused by the continuity of a beam at an interior support: a negative bending moment is induced in the beam. The beam in Figure 5.9b, therefore, has a profile with an inflection point, indicating a change of sign of the moment within the span. This span behaves in a manner similar to one of the spans in the two-span beam.

The beam with both ends restrained has two inflection points, with a switch of sign to negative bending moment near each end. Although values are slightly different for this beam, the general form of the deflected shape is similar to that for the middle span in the three-span beam (see Figure 5.8).

Although they have only one span, the beams in Figures 5.9b and c are both indeterminate. Investigation of the beam with one restrained end involves finding three unknowns: the two reactions plus the restraining moment at the fixed end. For the beam in Figure 5.9c, there are four unknowns. There are, however, only a few ordinary cases that cover most common situations, and tabulations of formulas for these ordinary cases are readily available from references. Figure 5.10 gives values for the beams with one and two fixed ends under both uniformly distributed load and a single concentrated load at center span. Values for other loadings are also available from references.



**Figure 5.9** Deflected shape of the single-span beam. (a) With simple supports. (b) With one end fixed. (c) With both ends fixed.



**Figure 5.10** Values and diagrams for single-span beams with restrained supports.

**Example 5.** Figure 5.11a represents a 20-ft span beam with both ends fixed and a total uniformly distributed load of 8 kips. Find the reactions and construct the complete shear and moment diagrams.

**Solution:** Despite the fact that this beam is indeterminate to the second degree (four unknowns; only two equations of static equilibrium), its symmetry makes some investigation data self-evident. Thus, it can be observed that the two vertical reaction forces, and thus, the two end shear values, are each equal to one half of the total load, or 4000 lb. Symmetry also indicates that the location of the point of zero moment, and thus, the

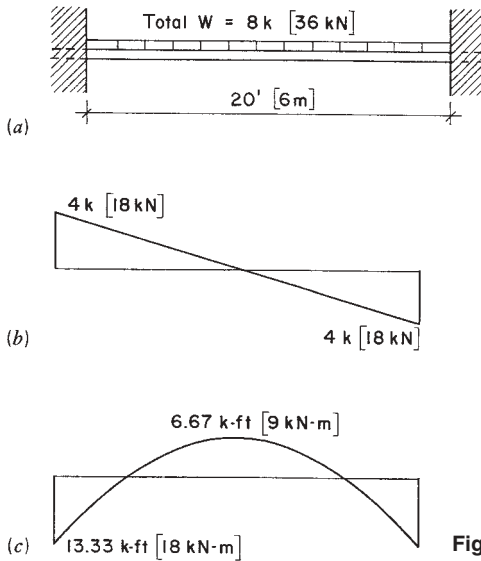


Figure 5.11 Example 5.

point of maximum positive bending moment, is at the center of the span. Also, the end moments, although indeterminate, are equal to each other, leaving only a single value to be determined.

From data in Figure 5.10a, the negative end moment is  $0.0833WL$  (actually  $WL/12$ ) =  $(8000 \times 20)/12 = 13,333$  ft-lb. The maximum positive moment at midspan is  $0.04167WL$  (actually  $WL/24$ ) =  $(8000 \times 20)/24 = 6667$  ft-lb. And the point of zero moment is  $0.212L = (0.212)(20) = 4.24$  ft from the beam end. The complete shear and moment diagrams are as shown in Figures 5.11b and c.

**Example 6.** A beam fixed at one end and simply supported at the other end has a span of 20 ft and a total uniformly distributed load of 8000 lb (Figure 5.12a). Find the reactions and construct the shear and moment diagrams.

**Solution:** This is the same span and loading as in the preceding example. Here, however, one end is fixed and the other simply supported (the loading case shown in Figure 5.10c). The beam vertical reactions are equal to the end shears; thus, from the data in Figure 5.10c,

$$R_1 = V_1 = 0.375(8000) = 3000 \text{ lb}$$

$$R_2 = V_2 = 0.625(8000) = 5000 \text{ lb}$$

and for the maximum moments

$$+M = 0.0703(8000 \times 20) = 11,248 \text{ ft-lb}$$

$$-M = 0.125(8000 \times 20) = 20,000 \text{ ft-lb}$$

The point of zero shear is at  $0.375(20) = 7.5$  ft from the left end, and the point of zero moment is at twice this distance, 15 ft, from the left end. The complete shear and moment diagrams are shown in Figures 5.12*b* and *c*.

**Problem 5.2.A**

A 22-ft [6.71-m] span beam is fixed at both ends and carries a single concentrated load of 16 kips [71.2 kN] at midspan. Find the reactions and construct the complete shear and moment diagrams.

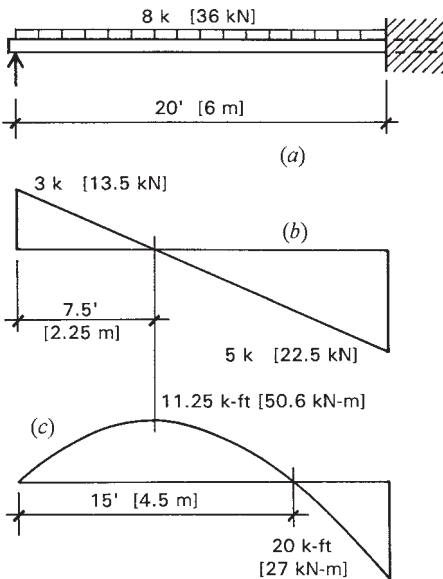


Figure 5.12 Example 6.

**Problem 5.2.B**

A 16-ft [4.88-m] span beam is fixed at one end and simply supported at the other end. A single concentrated load of 9600 lb [42.7 kN] is placed at the center of the span. Find the vertical reactions and construct the complete shear and moment diagrams.

**5.3 BEAMS WITH INTERNAL PINS**

In many structures, conditions exist at supports or within the structure that modify the behavior of the structure, often eliminating some potential components of force actions. Qualification of supports as fixed or pinned (not rotation-restrained) has been a situation in most of the structures presented in this work. We now consider some qualification of conditions *within* the structure that modify its behavior.

**Internal Pins**

Within a structure, members may be connected in a variety of ways. If a structural joint is qualified as *pinned*, it is considered to be capable only of transfer of direct forces of shear, tension, or compression. Such joints are commonly used for wood and steel framed structures. In some cases, a pinned joint may deliberately be used to eliminate the possibility for transfer of bending moment through the joint; such is the case in the following examples.

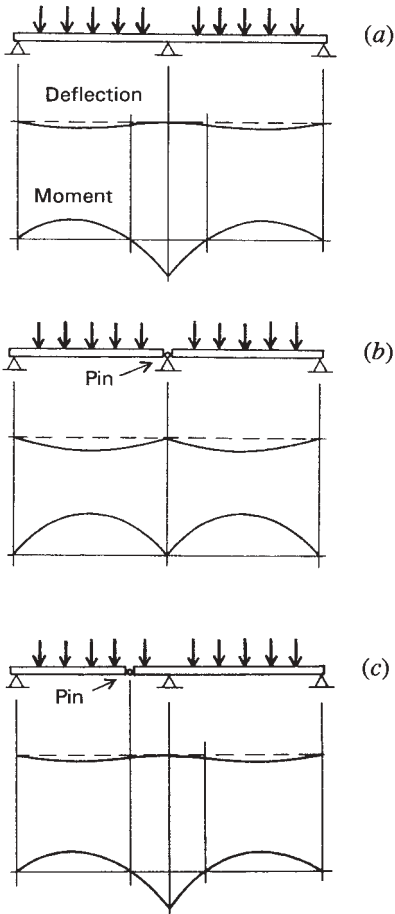
**Continuous Beams with Internal Pins**

The typical continuous beam, such as that shown in Figure 5.13*a*, is statically indeterminate, in this case having a number of reaction components (three) in excess of the conditions of equilibrium for the parallel force system (two). The continuity of such a beam results in the deflected shape and variation of moment as shown beneath the beam in Figure 5.13*a*. If the beam is made discontinuous at the middle support, as shown in Figure 5.13*b*, the two spans each behave independently as simple beams, with the deflected shapes and moment as shown.

If a multiple-span beam is made internally discontinuous at some point off of the supports, its behavior may emulate that of a truly contin-



uous beam. For the beam shown in Figure 5.13c, the internal pin is located at the point where the continuous beam inflects. Inflection of the deflected shape is an indication of zero moment, and thus the pin does not actually change the continuous nature of the structure. The deflected shape and moment variation for the beam in Figure 5.13c is therefore the same as for the beam in Figure 5.13a. This is true, of course, only for



**Figure 5.13** Behavior of two-span beams. (a) As a continuous, single-piece beam. (b) As separate pieces in each span. (c) With internal pin in one span.

the single loading pattern that results in the inflection point at the same location as the internal pin.

In the first of the following examples, the internal pin is deliberately placed at the point where the beam would inflect if it were continuous. In the second example, the pins are placed slightly closer to the support, rather than in the location of the natural inflection points. The modification in the second example results in slightly increasing the positive moment in the outer spans, while reducing the negative moments at the supports; thus, the values of maximum moment are made closer. If it is desired to use a single-size beam for the entire length, the modification in Example 8 permits design selection of a slightly smaller size member.

**Example 7.** Investigate the beam shown in Figure 5.14*a*. Find the reactions, draw the shear and moment diagrams, and sketch the deflected shape.

*Solution:* Because of the internal pin, the first 12 ft of the left-hand span acts as a simple beam. Its two reactions are therefore equal, being one-half the total load, and its shear, moment, and deflected shape diagrams are those for a simple beam with a uniformly distributed load. (See Case 2, Figure 4.20.) As shown in Figures 5.14*b* and *c*, the simple beam reaction at the right end of the 12-ft portion of the left span becomes a 6-kip concentrated load at the left end of the remainder of the beam. This beam (Figure 5.14*c*) is then investigated as a beam with one overhanging end, carrying a single concentrated load at the cantilevered end and the total distributed load of 20 kips. (Note that on the diagram the total uniformly distributed load is indicated in the form of a single force, representing its resultant). The second portion of the beam is statically determinate, and its reactions can now be determined by statics equations.

With the reactions known, the shear diagram can be completed. Note the relation between the point of zero shear in the span and the location of maximum positive moment. For this loading, the positive moment curve is symmetrical, and thus the location of the zero moment (and beam inflection) is at twice the distance from the end as the point of zero shear. As noted previously, the pin in this example is located exactly at the inflection point of the continuous beam. (For comparison, see Section 5.1, Example 1.)

**Example 8.** Investigate the beam shown in Figure 5.15.

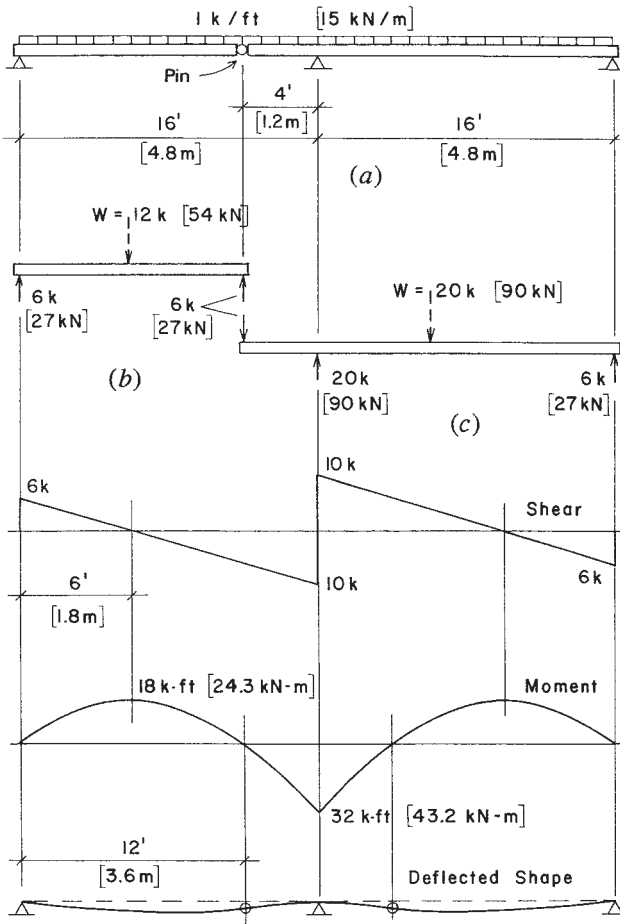


Figure 5.14 Example 7.

*Solution:* The procedure is essentially the same as for Example 7. Note that this beam with four supports requires two internal pins to become statically determinate. As before, the investigation begins with the consideration of the two end portions acting as simple beams. The second step is to consider the center portion as a beam with two overhanging ends.

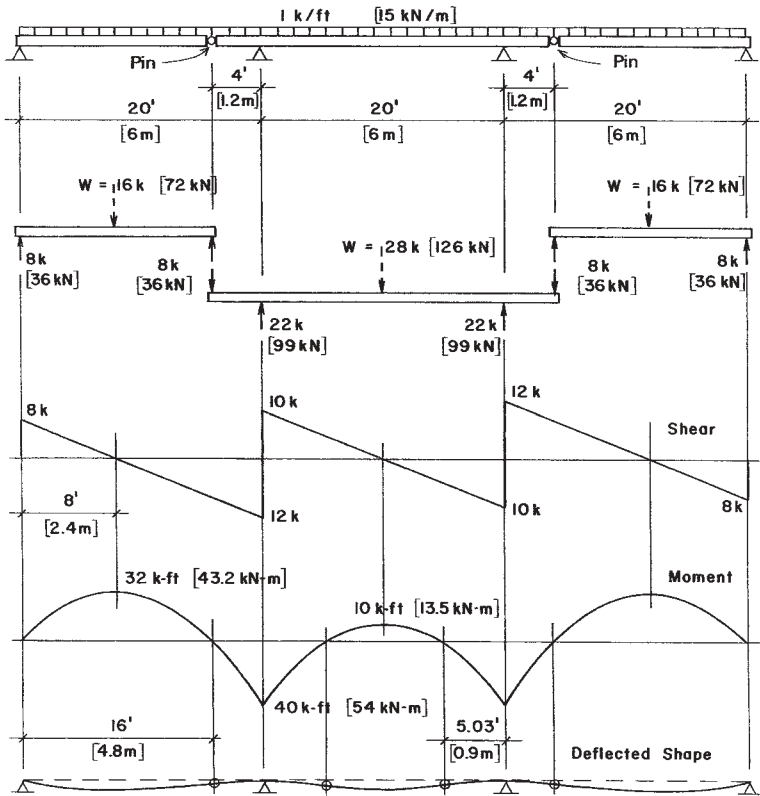


Figure 5.15 Example 8.

**Problems 5.3.A–C**

Investigate the beams shown in Figures 5.16a–c. Find the reactions and draw the shear and moment diagrams, indicating all critical values. Sketch the deflected shapes and determine the locations of any inflection points not related to the internal pins. (Note: Problem 5.3.B has the same spans and loading as Example 2 in Section 5.1.)

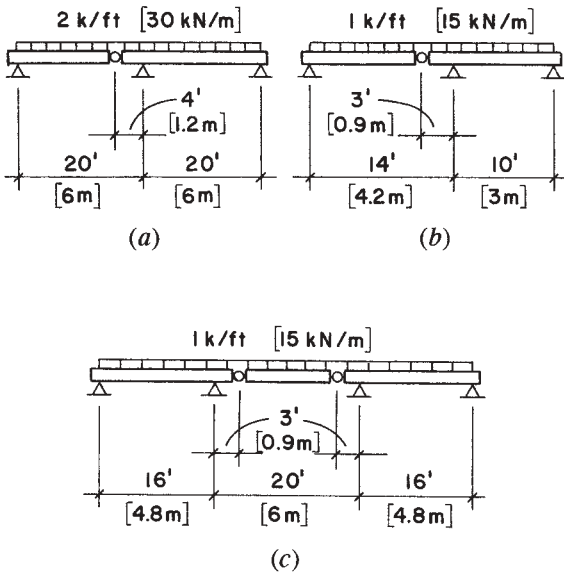


Figure 5.16 Problems 5.3.A–C.

## 5.4 APPROXIMATE ANALYSIS OF CONTINUOUS BEAMS

In some situations, it may be acceptable to perform an approximate analysis of a continuous beam for the purpose of its design. This process may be adequate for actual construction or may be simply a first approximation in a multistage design process in which some aspects of the beam must be defined before an exact analysis can proceed.

The ACI Code (Ref. 4) permits analysis of some continuous reinforced concrete beams by approximate methods. Use of these methods is limited by several conditions, including those of only uniformly distributed loads, a relatively high dead load in proportion to live load, and approximately equal values for the beam spans. Figure 5.17 shows a summary of the approximation factors used to establish design moments and design shears with this method. Values displayed may be compared with those indicated for various load, span, and support conditions in Figures 4.20, 5.8, and 5.10.

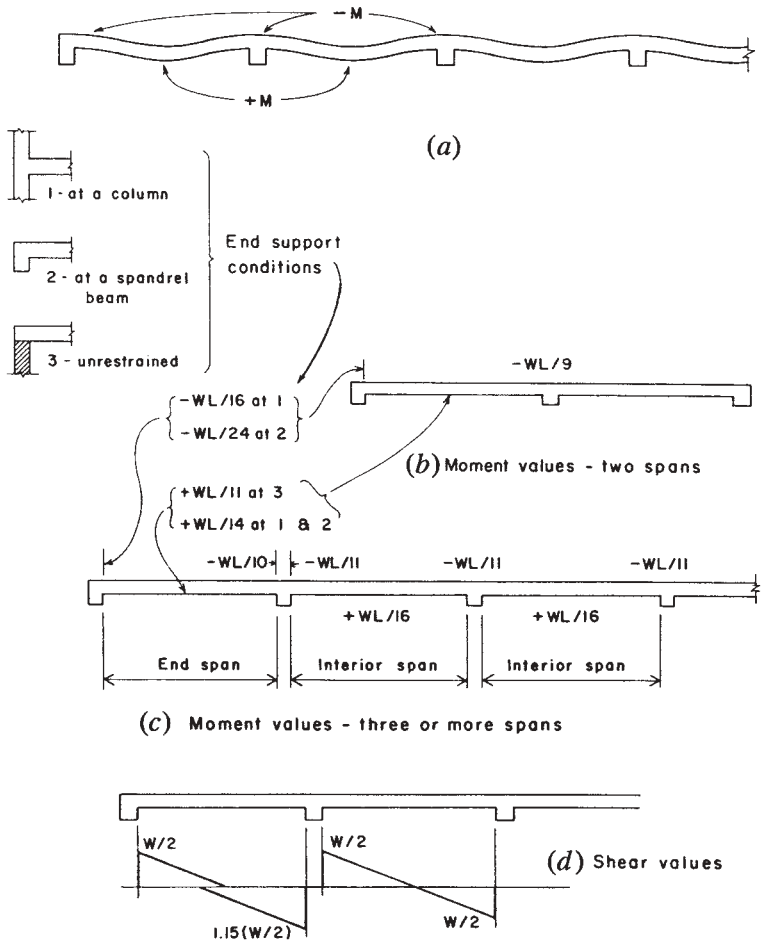


Figure 5.17 Approximate design factors for continuous beams.

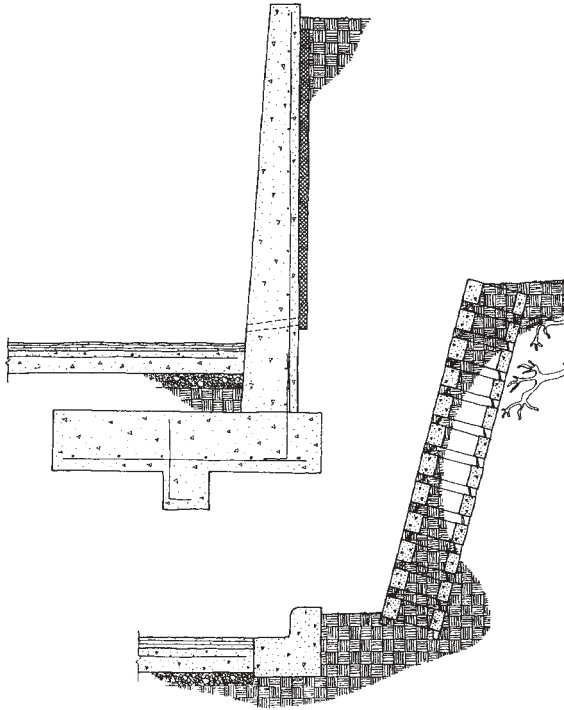
# 6

---

## RETAINING WALLS

---

Strictly speaking, any wall that sustains significant lateral soil pressure is a retaining wall. That definition includes basement walls, but the term is usually applied to site structures outside of buildings (see Figure 6.1). For the site retaining wall, a critical concern is for the dimension of the difference in the ground surface elevation on the two sides of the wall. The greater this dimension, the more the lateral force that will be exerted on the wall, attempting to topple the wall onto the lower side. This chapter treats some aspects of the structural behavior of the *cantilever retaining wall*, an example of which is shown in the upper figure in Figure 6.1. The three major concerns for such a structure are its stability against sliding, against overturning (toppling), and the maximum soil pressure developed on the bottom of the footing. The latter two effects will be considered here.



**Figure 6.1** Achieving abrupt changes in the elevation of the ground surface has been accomplished by various means over the years. Shown here are two forms of construction in current use, depending on various requirements. The semi-open interlocking units shown in the lower drawing permit easy drainage of the soil mass behind the wall and let air get to roots of plant growth behind the wall. But a common solution for abrupt changes of significant height is the cantilever structure of reinforced concrete or masonry, as shown in the upper drawing.

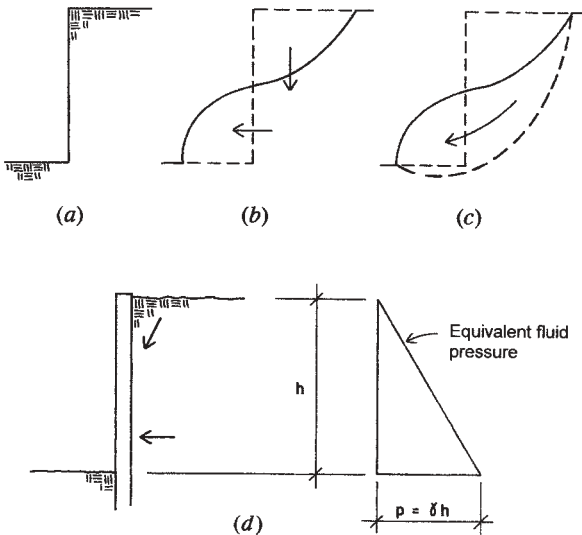
## 6.1 HORIZONTAL EARTH PRESSURE

Horizontal earth pressures are classified as either active or passive. Passive pressure is the resistance offered by a soil mass to something being pushed against it. For example, passive pressure against the sides of a building's below-grade construction is generally what resists the overall push of the wind against the building.



Active pressure is that exerted by a soil mass against some restraining structure, such as a basement wall or a retaining wall. This is the form of pressure that will be treated here. The nature of active horizontal soil pressure can be visualized by considering the situation of an unrestrained vertical cut in a soil mass, as shown in Figure 6.2*a*. In most soils, such a cut will not stand for long. Under the action of various influences—primarily gravity—the soil mass will tend to move to the profile shown in Figure 6.2*b*.

There are two force effects that tend to move the soil mass at the vertical cut. First is the simple downward push of the soil at the top of the cut. The second effect is the outward horizontal push by the soil at the bottom of the cut, responding to the downward push of the soil above. A common form of the actual soil movement consists of the rotational slip of the soil mass along a curved slip plane, as shown in Figure 6.2*c*, with the slip plane indicated by the dashed line.



**Figure 6.2** Aspects of the development of lateral soil pressure. (a) Unrestrained vertical cut. (b) General form of failure at the face of a vertical cut. (c) Common form of failure by rotational slip. (d) Net force effect by the soil on a bracing structure at the cut soil face and indication of the form of horizontal pressure assumed in the equivalent fluid method.

If a restraining structure is placed at the cut face, the force effects described for the unrestrained soil will be exerted against the restraining structure, as shown in Figure 6.2*d*. The most critical part of this effect on the restraining structure is the horizontal push; consequently, a common practice for design is to consider the soil mass to behave in the manner of an equivalent fluid, with pressure varying directly with the height, as it does on the side of a water tank. This pressure variation is shown in Figure 6.2*d*, with the maximum pressure at the base of the wall indicated as some constant times the wall height. For a pure fluid, this constant would be the unit density (weight) of the fluid. For soil, it is some partial fraction of the soil weight, typically about one-third.

## 6.2 STABILITY OF RETAINING WALLS

The two basic concerns for stability of a retaining wall are with regard to its toppling (rotation) and its sliding in a horizontal direction away from the cut face of soil. A typical investigation for toppling (more often called overturning) is to do a summation of the rotational moments of all the forces on the wall about a point at the low side toe of its foundation. This analysis is demonstrated in the following example.

**Example 1.** Investigate the safety of the concrete retaining wall shown in Figure 6.3*a* with regard to rotation about the toe of its footing. Use the following data:

Lateral soil pressure = 30 psf/ft of height

Soil weight = 100 pcf

Concrete weight = 150 pcf

**Solution:** The loading condition for this analysis is shown in Figure 6.3*b*. Rotation about the lower left corner of the footing (toe) is induced by the single horizontal force, acting as a resultant at one-third the height of the triangular pressure variation. Resistance to this rotation is offered by the weight of the wall itself and by the weight of the soil above the footing. At a minimum, the effect of the soil behind the wall is taken as the component  $W_3$ , which is the soil mass directly above the footing. The computation of the component forces and their moments is summarized in Table 6.1.

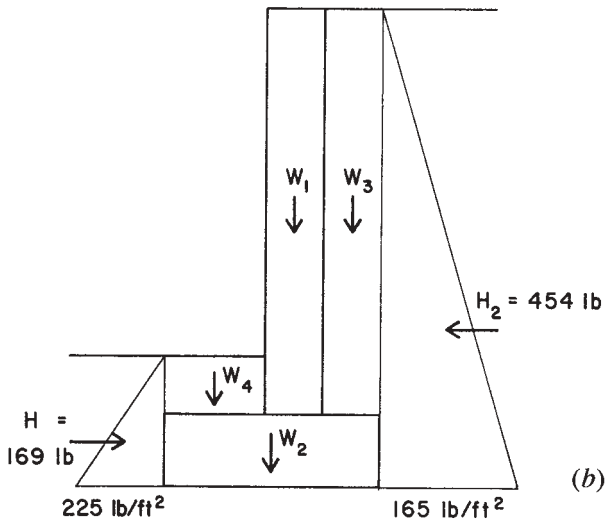
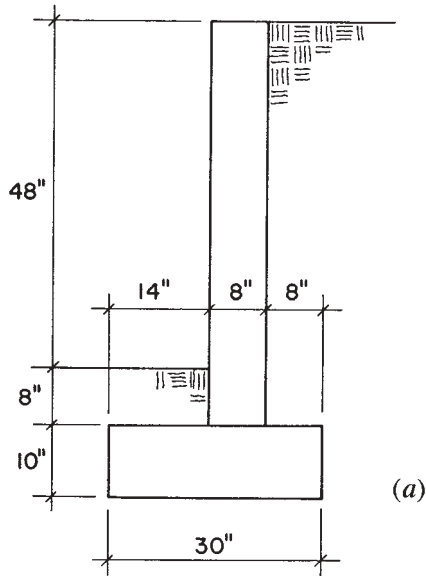


Figure 6.3 Example 1.

**TABLE 6.1 Analysis for Overturning Effect**

Force, lb	Moment Arm, in.	Moment, lb-in.
<i>Overturn</i>		
$H = \frac{1}{2} \times 5.5 \times 165 = 454$	22	$M_1 = -9988$
<i>Restoring Moment</i>		
$w_1 = 0.667 \times 4.667 \times 150 = 467$	18	8406
$w_2 = (10/12) \times 2.5 \times 150 = 312$	15	4680
$w_3 = 0.667 \times 4.667 \times 100 = 311$	26	8086
$w_4 = (14/12) \times 0.667 \times 100 = 78$	7	546
Totals	$\Sigma W = 1168$	$M_2 = +21,718$

Safety is indicated by the ratio of the resisting moment to the overturning moment, a computation usually described as the *safety factor*. In this example, the safety factor  $SF$  against overturn is thus

$$SF = \frac{(\text{resisting moment})}{(\text{overturning moment})} = \frac{21,700}{9988} = 2.17$$

Whether this is adequate safety or not is a judgement for the designer. In most cases, building codes require a minimum safety factor of 1.5 for this situation, in which case the wall seems quite adequate.

### **Problems 6.2.A, B**

Investigate the stability of the concrete retaining walls shown in Figure 6.4 with regard to overturning. Use the data given in Example 1.

## **6.3 VERTICAL SOIL PRESSURE**

Stability of a cantilever retaining wall depends partly on the resistance of the supporting soil beneath the wall footing. If this is a highly compressible soil, the footing may settle considerably. While a direct vertical settlement of some minor dimension is to be expected, of greater concern is the effect of a nonuniformly distributed pressure on the bottom of the footing. With a major horizontal force exerted on the retaining wall, this may well be the case; thus, an investigation is often made for the actual vertical pressure.

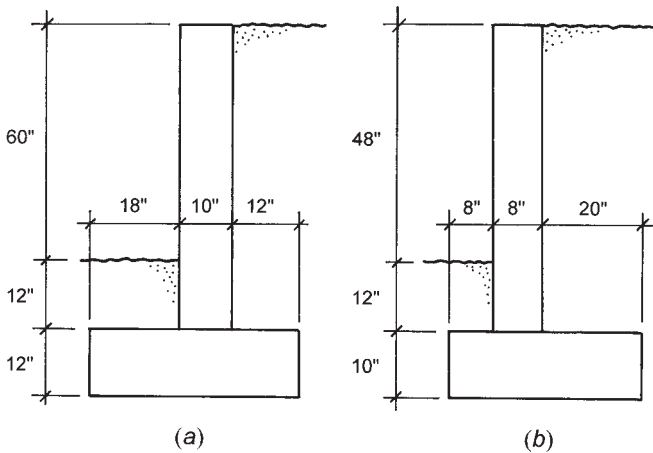


Figure 6.4 Problems 6.2.A, B.

Unless the vertical loads are exactly centered on the footing, and the resisting moment exactly equals the overturning moments, there is likely to be some net moment at the bottom of the footing. The usual practice is to investigate for the combination of vertical compression due to the vertical forces, and add to it any vertical stress due to a bending moment with respect to the center of the footing. The general form of such an analysis is demonstrated in Section 13.2, Example 1. The method presented there is used in the following example.

**Example 2.** Investigate the retaining wall in Example 1 (Figure 6.3) for the maximum vertical soil pressure at the bottom of the footing.

*Solution:* The vertical soil pressure at the bottom of the footing is produced by the combination of the vertical load and the net moment with regard to the center of the footing. The true loading condition, as a result of the vertical and horizontal loads shown in Figure 6.3, is indicated by the resultant shown in Figure 6.5a. At the base of the footing, the eccentricity of this resultant from the toe of the footing can be computed from the sum of the vertical load and the net moment about the toe. The data for this computation are provided in Table 6.1. Thus, the eccentricity  $e_1$  is found as

$$e_1 = \frac{M_2 - M_1}{\Sigma W} = \frac{21,718 - 9988}{1168} = 10.04 \text{ in.}$$

Referring to Figure 6.5*a*, with the value for  $e_1$  determined, the distance indicated as  $e_2$  may be found by subtraction from the dimension of one-half the footing width. Thus,  $e_2 = 15 - 10.04 = 4.96$  in. This is the eccentricity that relates to the combined stress analysis for the footing vertical soil pressure.

A first determination at this point is that made with regard to the significance of the eccentricity with respect to the kern of the footing (see discussion in Section 13.2). For this case, the kern limit is one-sixth of the footing width, or 5 in. The eccentricity as computed is thus seen to be just inside the limit, allowing for an investigation for Case 1, as shown in Figure 13.5. The analysis for this is illustrated in Figure 6.5*b*, and the computation of the stress is shown in Figure 6.5*c*. The two components for this computation are as follows:

1. For the normal compression stress,

$$p = \frac{N}{A} = \frac{\Sigma W}{A} = \frac{1168}{1 \times 2.5} = 467 \text{ psf}$$

2. For the bending stress,

$$S = \frac{bd^2}{6} = \frac{1 \times (2.5)^2}{6} = 1.042 \text{ ft}^3$$

Then

$$p = \frac{M}{S} = \frac{\Sigma W \times e_2}{S} = \frac{1168 \times (4.96 / 12)}{1.042} = 463 \text{ psf}$$

The limiting values of the combined stress, as shown in Figure 6.5*c*, are thus 930 psf and 4 psf.

### **Problems 6.3.A, B**

Compute the values for the vertical soil pressure for the retaining walls in Figures 6.4*a* and *b*.

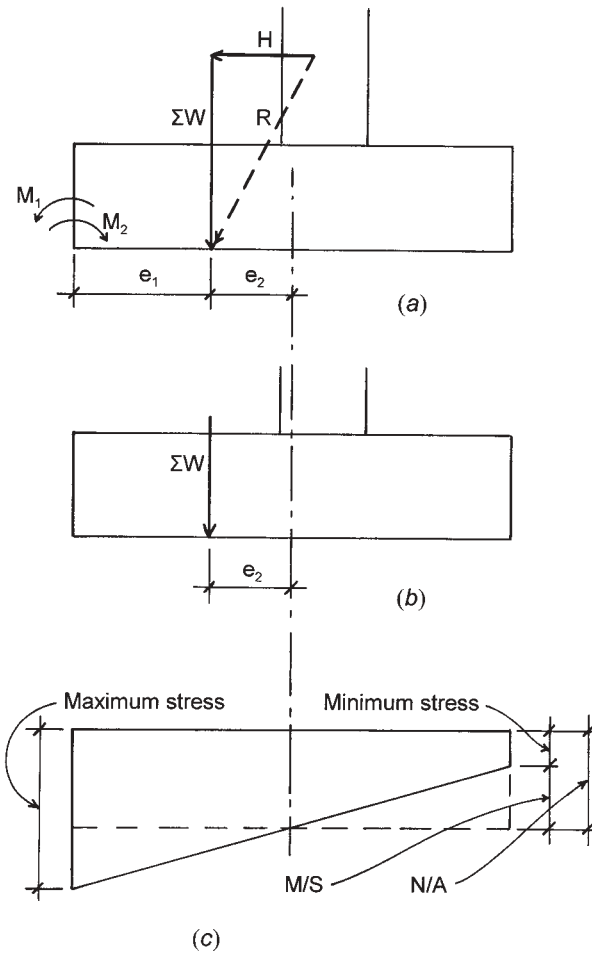


Figure 6.5 Example 2.

# 7

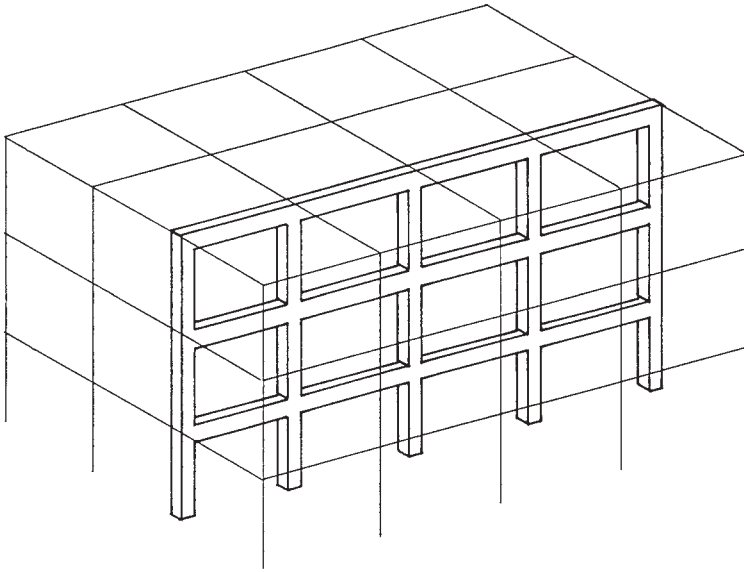
---

## RIGID FRAMES

---

Frames in which two or more of the members are attached to each other with connections that are capable of transmitting bending between the ends of the members are called *rigid frames*. The connections used to achieve such a frame are called *moment connections* or *moment-resisting connections*. Most rigid frame structures are statically indeterminate and do not yield to investigation by consideration of static equilibrium alone. The rigid-frame structure occurs quite frequently as a multiple-level, multiple-span bent, constituting part of the structure for a multistory building (see Figure 7.1). In most cases, such a bent is used as a lateral bracing element, although once it is formed as a moment-resistive framework, it will respond as such for all types of loads. The computational examples presented in this section are all rigid frames that have conditions that make them statically determinate and thus capable of being fully investigated by methods developed in this book.





**Figure 7.1** The rigid frame derives its name from the nature of the joint between the frame members—being one that rigidly resists the rotation of member ends with respect to each other at the joint. Sitecast concrete frames develop this quality naturally, and steel frames may be formed with special connections to develop the rigid joints. Individual rows of beams and columns may be visualized as planar rigid frames in such construction—as shown here.

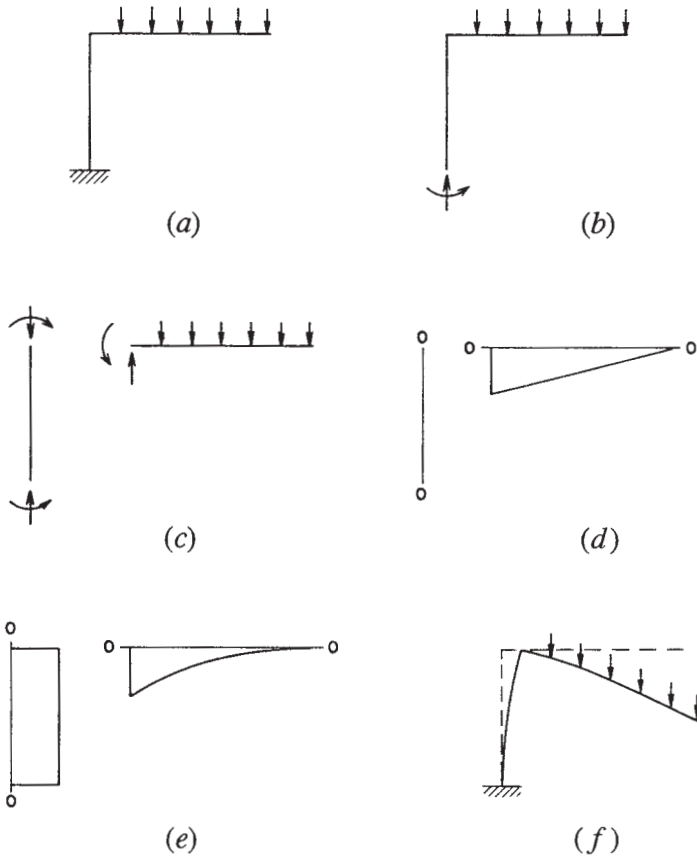
## 7.1 CANTILEVER FRAMES

Consider the frame shown in Figure 7.2*a*, consisting of two members rigidly joined at their intersection. The vertical member is fixed at its base, providing the necessary support condition for stability of the frame. The horizontal member is loaded with a uniformly distributed loading and functions as a simple cantilever beam. The frame is described as a cantilever frame because of the single fixed support. The five sets of figures shown in Figures 7.2*b* through *f* are useful elements for the investigation of the behavior of the frame. They consist of the following:

1. The free-body diagram of the entire frame, showing the loads and the components of the reactions (Figure 7.2*b*). Study of this figure will help in establishing the nature of the reactions and in the determination of the conditions necessary for stability of the frame as a whole.
2. The free-body diagrams of the individual elements (Figure 7.2*c*). These are of great value in visualizing the interaction of the parts of the frame. They are also useful in the computations for the internal forces in the frame.
3. The shear diagrams of the individual elements (Figure 7.2*d*). These are sometimes useful for visualizing, or for actually computing, the variations of moment in the individual elements. No particular sign convention is necessary unless in conformity with the sign used for moment.
4. The moment diagrams for the individual elements (Figure 7.2*e*). These are very useful, especially in determination of the deformation of the frame. The sign convention used is that of plotting the moment on the compression (concave) side of the flexed element.
5. The deformed shape of the loaded frame (Figure 7.2*f*). This is the exaggerated profile of the bent frame, usually superimposed on an outline of the unloaded frame for reference. This is very useful for the general visualization of the frame behavior. It is particularly useful for determination of the character of the external reactions and the form of interaction between the parts of the frame. Correlation between the deformed shape and the form of the moment diagram is a useful check.

When performing investigations, these elements are not usually produced in the sequence just described. In fact, it is generally recommended that the deformed shape be sketched first so that its correlation with other factors in the investigation may be used as a check on the work. The following examples illustrate the process of investigation for simple cantilever frames.

**Example 1.** Find the components of the reactions and draw the free-body diagrams, shear and moment diagrams, and the deformed shape of the frame shown in Figure 7.3*a*.



**Figure 7.2** Diagrams for investigation of the rigid frame.

*Solution:* The first step is the determination of the reactions. Considering the free-body diagram of the whole frame (Figure 7.3b),

$$\Sigma F = 0 = +8 - R_v, \quad R_v = 8 \text{ kips (up)}$$

and with respect to the support,

$$\Sigma M = 0 = M_R - (8 \times 4), \quad M_R = 32 \text{ kip-ft (clockwise)}$$

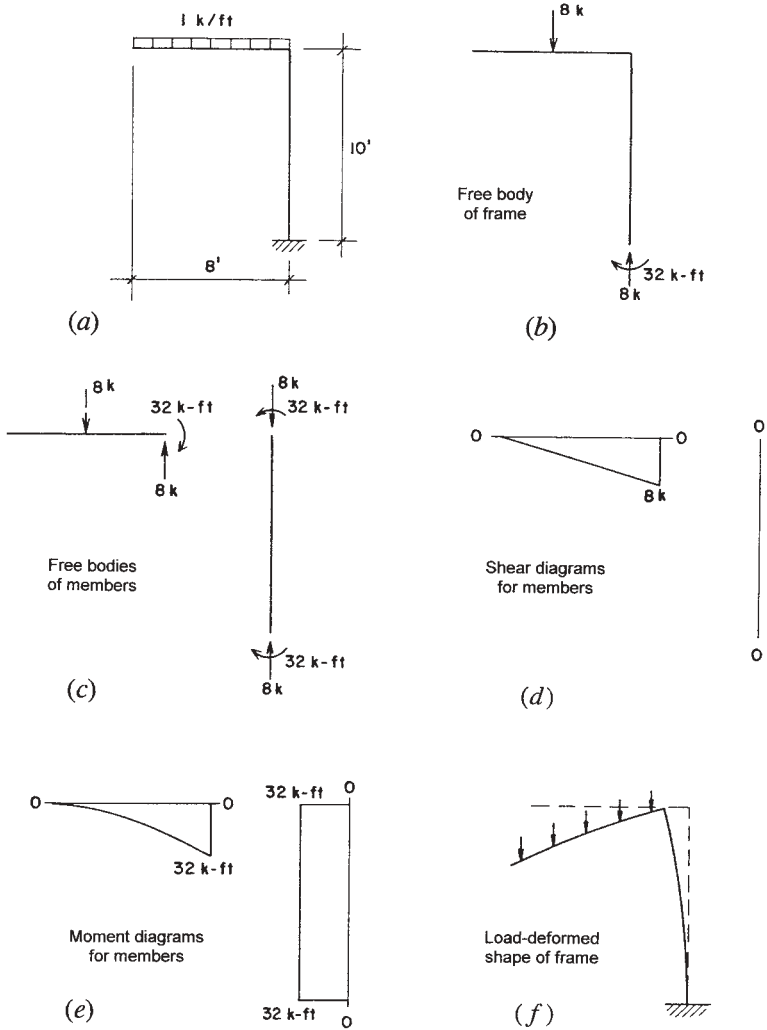


Figure 7.3 Example 1.

Note that the sense, or sign, of the reaction components is visualized from the logical development of the free-body diagram.

Consideration of the free-body diagrams of the individual members will yield the actions required to be transmitted by the moment connection. These may be computed by application of the conditions for equilibrium for either of the members of the frame. Note that the sense of the force and moment is opposite for the two members, simply indicating that what one does to the other is the opposite of what is done to it.

In this example there is no shear in the vertical member. As a result, there is no variation in the moment from the top to the bottom of the member. The free-body diagram of the member, the shear and moment diagrams, and the deformed shape should all corroborate this fact. The shear and moment diagrams for the horizontal member are simply those for a cantilever beam.

It is possible with this example, as with many simple frames, to visualize the nature of the deformed shape without recourse to any mathematical computations. It is advisable to attempt to do so as a first step in investigation, and to check continually during the work that individual computations are logical with regard to the nature of the deformed structure.

**Example 2.** Find the components of the reactions and draw the shear and moment diagrams and the deformed shape of the frame in Figure 7.4a.

*Solution.* In this frame, there are three reaction components required for stability, since the loads and reactions constitute a general coplanar force system. Using the free-body diagram of the whole frame (Figure 7.4b), the three conditions for equilibrium for a coplanar system are used to find the horizontal and vertical reaction components and the moment component. If necessary, the reaction force components could be combined into a single-force vector, although this is seldom required for design purposes.

Note that the inflection occurs in the larger vertical member because the moment of the horizontal load about the support is greater than that of the vertical load. In this case, this computation must be done before the deformed shape can be accurately drawn.

The reader should verify that the free-body diagrams of the individual members are truly in equilibrium and that there is the required correlation between all the diagrams.

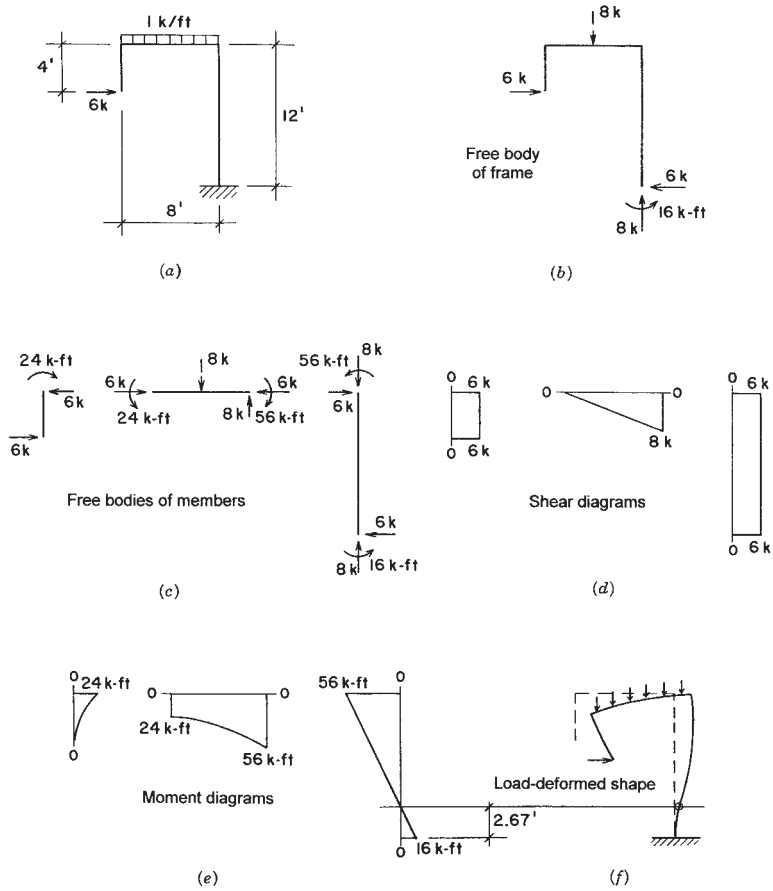


Figure 7.4 Example 2.

**Problems 7.1.A–C**

For the frames shown in Figure 7.5a–c, find the components of the reactions, draw the free-body diagrams of the whole frame and the individual members, draw the shear and moment diagrams for the individual members, and sketch the deformed shape of the loaded structure.

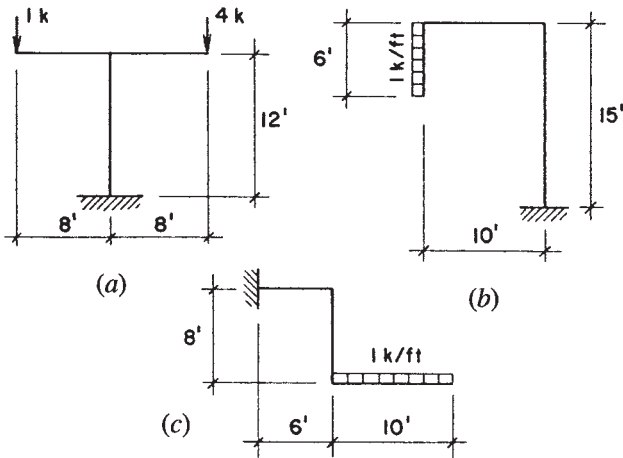


Figure 7.5 Problems 7.1.A-C.

## 7.2 SINGLE-SPAN FRAMES

Single-span rigid frames with two supports are ordinarily statically indeterminate. The following example illustrates the case of a statically determinate, single-span frame, made so by the particular conditions of its support and internal construction. In fact, these conditions are technically achievable, but a little weird for practical use. The example is offered here as an exercise for readers, an exercise that is within the scope of the work in this section.

**Example 3.** Investigate the frame shown in Figure 7.6 for the reactions and internal conditions. Note that the right-hand support allows for an upward vertical reaction only, whereas the left-hand support allows for both vertical and horizontal components. Neither support provides moment resistance.

**Solution:** The typical elements of investigation, as illustrated for the preceding examples, are shown in Figure 7.6. The suggested procedure for the work is as follows:

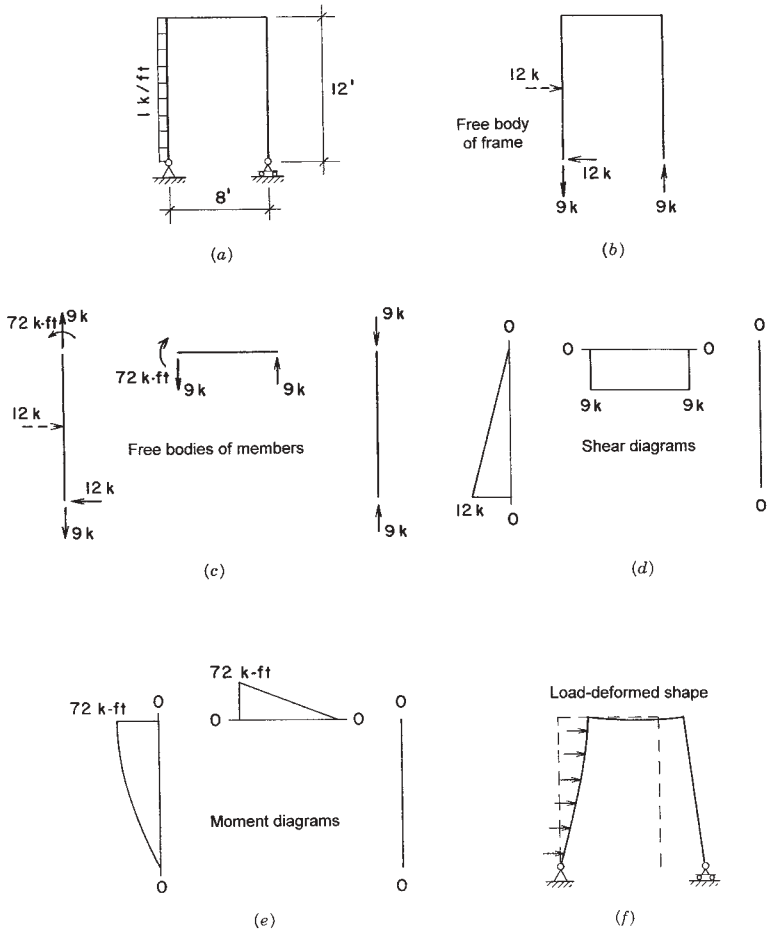


Figure 7.6 Example 3.



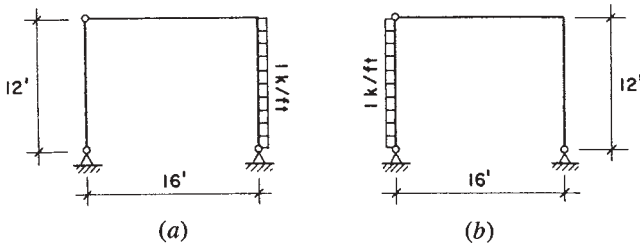


Figure 7.7 Problems 7.2.A, B.

1. Sketch the deflected shape (a little tricky in this case, but a good exercise).
2. Consider the equilibrium of the free-body diagram for the whole frame to find the reactions.
3. Consider the equilibrium of the left-hand vertical member to find the internal actions at its top.
4. Proceed to the equilibrium of the horizontal member.
5. Finally, consider the equilibrium of the right-hand vertical member.
6. Draw the shear and moment diagrams and check for correlation of all work.

Before attempting the exercise problems, the reader is advised to attempt to produce the results shown in Figure 7.6 independently.

### **Problems 7.2.A, B**

Investigate the frames shown in Figures 7.7a and b for reactions and internal conditions, using the procedure shown for the preceding examples.

# 8

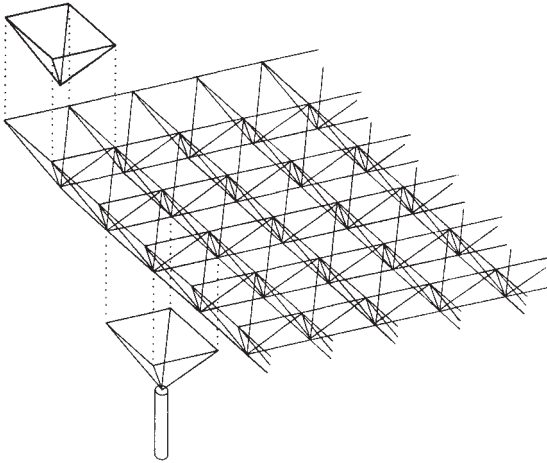
---

## NONCOPLANAR FORCE SYSTEMS

---

Forces and structures exist in reality in a three-dimensional world (see Figure 8.1). The work in preceding chapters has been limited mostly to systems of forces operating in two-dimensional planes. This is commonly done in design practice, primarily for the same reasons that we have done it here: it makes both visualization and computations easier. As long as the full three-dimensional character of the forces and the structures is eventually dealt with, this approach is usually quite adequate. For visualization, as well as for some computations, however, it is sometimes necessary to work directly with forces in noncoplanar systems. This chapter presents some exercises that will help in the development of an awareness of the problems of working with such force systems.

Graphical representation, visualization, and any mathematical computation all become more complex with noncoplanar systems. The following discussions rely heavily on the examples to illustrate basic concepts and procedures. The orthogonal axis system  $x$ - $y$ - $z$  is used for ease of both visualization and computation.



**Figure 8.1** All building structures are three-dimensional in their general form. Nevertheless, most can be broken down into component linear and planar (two-dimensional) elements for investigation of behavior. However, some systems are fundamentally three-dimensional and must be treated as such for investigation. The two-way spanning truss—also called a space frame—is one such structure.

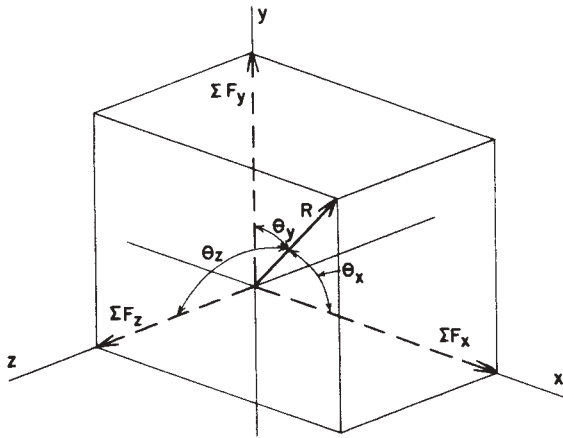
Units of measurement for both forces and dimensions are of small significance in this work. Because of this, and because of the complexity of both the graphical representations and the mathematical computations, the conversions for metric units have been omitted, except for the data and answers for the exercise problems.

## 8.1 CONCURRENT SYSTEMS

Figure 8.2 shows a single force acting in such a manner that it has component actions in three dimensions. That is, it has  $x$ ,  $y$ , and  $z$  components. If this force represents the resultant of a system of forces, it may be identified as follows:

For its magnitude,

$$R = \sqrt{(\Sigma F_x)^2 + (\Sigma F_y)^2 + (\Sigma F_z)^2}$$



**Figure 8.2** Components of a noncoplanar force.

and for its direction,

$$\cos \theta_x = \frac{\Sigma F_x}{R}, \quad \cos \theta_y = \frac{\Sigma F_y}{R}, \quad \cos \theta_z = \frac{\Sigma F_z}{R}$$

Equilibrium for this system can be established by fulfilling the following conditions:

$$\Sigma F_x = 0, \quad \Sigma F_y = 0, \quad \Sigma F_z = 0$$

**Example 1.** Find the resultant of the three forces shown in Figure 8.3a.

*Solution:* Various methods may be used, employing trigonometry, polar coordinates, and so on. The method used here is to first find the geometry of the force lines for the three forces. Then the vectors for the forces and their  $x$ ,  $y$ , and  $z$  components can be expressed using the proportionate values from the force line geometry. The construction for this computation is shown in Figure 8.3a.

Referring to the line lengths shown in Figure 8.3a:

$$L_1 = \sqrt{(5)^2 + (3)^2} = \sqrt{34} = 5.83$$

$$L_2 = \sqrt{(12)^2 + 34} = \sqrt{178} = 13.34$$

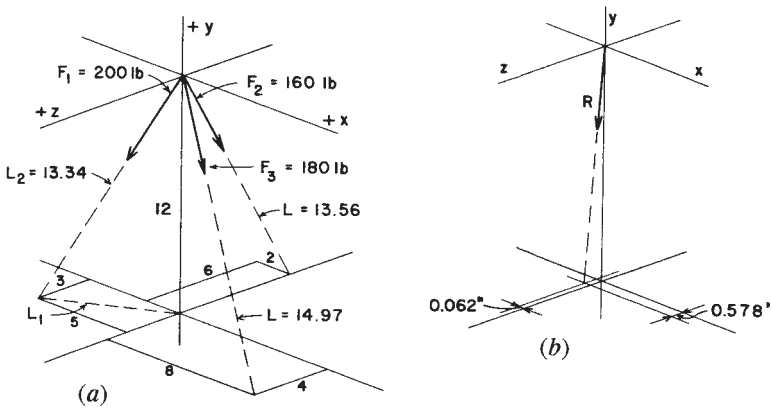


Figure 8.3 Example 1.

Note: To reinforce the point that the unit of measurement for dimensions is not relevant for these computations, it is omitted.

The other line lengths can be determined in the same manner. Their values are shown on the figure. The determination of the force components and their summation is presented in Table 8.1. Note that the sense of the components is established with reference to the positive directions indicated for the three axes, as shown in Figure 8.3a. To aid in visualization, the sense of the forces in Table 8.1 is indicated with arrows, rather than with plus and minus signs.

Using the summations from the table, the value of the resultant is determined as

$$R = \sqrt{(2.4)^2 + (466.1)^2 + (22.4)^2} = \sqrt{217,757} = 466.7$$

TABLE 8.1 Summation of Forces, Example 1

Force	x Component	y Component	z Component
$F_1$	$200(5/13.34) = 75 \curvearrowleft$	$200(12/13.34) = 180 \downarrow$	$200(3/13.34) = 45 \swarrow$
$F_2$	$160(2/13.56) = 23.6 \curvearrowleft$	$160(12/13.56) = 141.7 \downarrow$	$160(6/13.56) = 70.8 \nearrow$
$F_3$	$180(8/14.97) = \underline{96.2} \searrow$	$180(12/14.97) = \underline{144.4} \downarrow$	$180(4/14.97) = \underline{48.2} \swarrow$
	$\Sigma F_x = 2.4 \text{ lb } \curvearrowleft$	$\Sigma F_y = 466.1 \text{ lb } \downarrow$	$\Sigma F_z = 22.4 \text{ lb } \swarrow$

The direction of  $R$  may be established by expressing the three cosine equations, as described earlier, or by establishing its points of intersection with the  $x$ - $z$  plane, as shown in Figure 8.3*b*. Using the latter method, and calling the  $x$  distance from the  $z$ -axis  $L_3$ ,

$$\frac{\Sigma F_x}{\Sigma F_y} = \frac{L_3}{12} = \frac{2.4}{466.1}$$

Then

$$L_3 = \frac{22.4}{466.1}(12) = 0.62$$

And, similarly, calling the  $z$  distance from the  $x$ -axis  $L_4$ ,

$$L_4 = \frac{22.4}{466.1}(12) = 0.578$$

**Example 2.** For the structure shown in Figure 8.4*a*, find the tension in the guy wires and the compression in the mast for the loading indicated.

*Solution:* The basic problem here is the resolution of the concentric force system at the top of the mast. As in Example 1, the geometry of the wires is established first. Thus,

$$L = \sqrt{(9)^2 + (12)^2 + (20)^2} = \sqrt{626} = 25$$

Consider the concentric forces at the top of the mast. For equilibrium in the  $x$  direction,

$$\Sigma F_x = 0 = +1000 - 2(T_x), \quad T_x = 500 \text{ lb}$$

Then, from the geometry of the wire,

$$\begin{aligned} \frac{T}{T_x} &= \frac{25}{12} \\ T &= \frac{25}{12}(T_x) = \frac{25}{12}(500) = 1041.67 \text{ lb} \end{aligned}$$

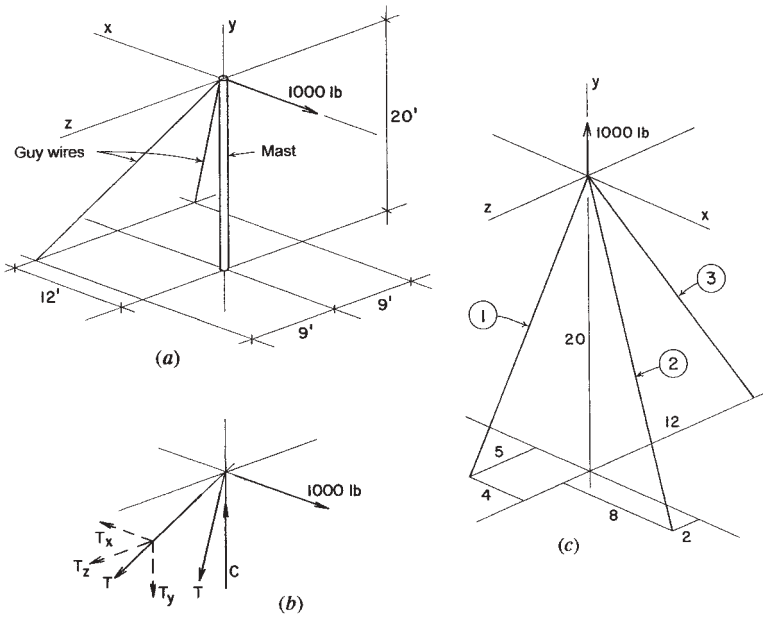


Figure 8.4 Examples 2 and 3.

For the compression in the mast, consider the equilibrium of the forces in the y direction. Thus,

$$\Sigma F_y = 0 = +C - 2(T_y), \quad C = 2(T_y)$$

where

$$\frac{T_y}{T_x} = \frac{20}{12}$$

$$T_y = \frac{20}{12}(T_x) = \frac{20}{12}(500)$$

Thus,

$$C = 2T_y = (2) \frac{20}{12} (500) = 1666.67 \text{ lb}$$

**Example 3.** Find the tension in each of the three wires in Figure 8.4c due to the force indicated.

*Solution:* As before, the first step is to find the lengths of the three wires. Thus,

$$L_1 = \sqrt{(5)^2 + (4)^2 + (20)^2} = \sqrt{441} = 21$$

$$L_2 = \sqrt{(2)^2 + (8)^2 + (20)^2} = \sqrt{468} = 21.63$$

$$L_3 = \sqrt{(12)^2 + (20)^2} = \sqrt{544} = 23.32$$

The three static equilibrium equations for the concentric forces are thus

$$\Sigma F_x = 0 = +\frac{4}{21}(T_1) - \frac{8}{21.63}(T_2)$$

$$\Sigma F_y = 0 = +\frac{20}{21}(T_1) + \frac{20}{21.63}(T_2) + \frac{20}{23.32}(T_3) - 1000$$

$$\Sigma F_z = 0 = +\frac{5}{21}(T_1) + \frac{2}{21.63}(T_2) - \frac{12}{23.32}(T_3)$$

Solution of these three simultaneous equations with three unknowns yields the following:

$$T_1 = 525 \text{ lb}, \quad T_2 = 271 \text{ lb}, \quad T_3 = 290 \text{ lb}$$

**Problem 8.1.A**

Find the resultant of the three forces shown in Figure 8.5a. Establish the direction of the resultant by finding the coordinates of its intersection with the  $x$ - $z$  plane.

**Problem 8.1.B**

Find the compression force in the struts and the tension force in the wire for the structure in Figure 8.5b.

**Problem 8.1.C**

Find the tension force in each of the wires for the system shown in Figure 8.5c.



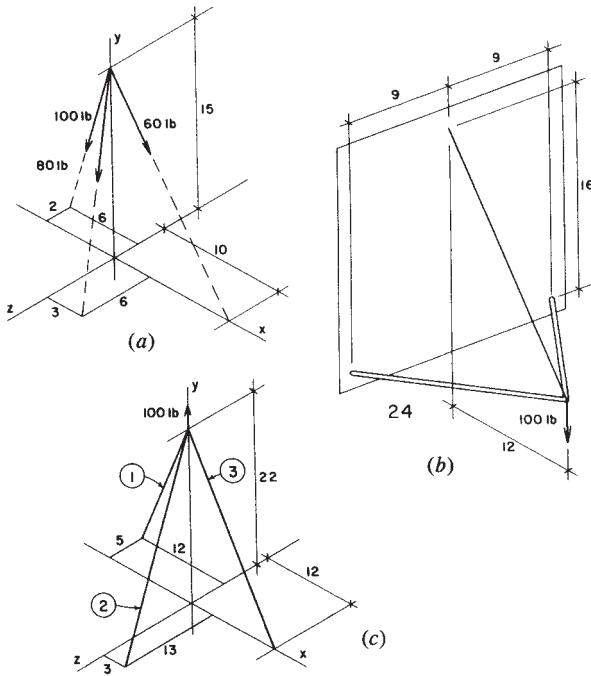


Figure 8.5 Problems 8.1.A–C.

## 8.2 PARALLEL SYSTEMS

Consider the force system shown in Figure 8.6. Assuming the direction of the forces to be parallel to the  $y$ -axis, the resultant force can be stated as

$$R = \Sigma F_y$$

and its location in the  $x$ - $z$  plane can be established by two moment equations, taken with respect to the  $x$ -axis and the  $z$ -axis; thus,

$$L_x = \frac{\Sigma M_z}{R} \quad \text{and} \quad L_z = \frac{\Sigma M_x}{R}$$

The static equilibrium for the system can be established by fulfilling the following conditions:

$$\Sigma F_y = 0, \quad \Sigma M_x = 0, \quad \Sigma M_z = 0$$

As with the coplanar parallel systems, the resultant may be a couple. That is, the summation of forces may be zero, but there may be a net rotational effect about the  $x$ -axis and/or the  $z$ -axis. When this is the case, the resultant couple may be visualized in terms of two component couples, one in the  $x$ - $y$  plane (for  $\Sigma M_z$ ) and one in the  $z$ - $y$  plane (for  $\Sigma M_x$ ). See Example 5 in the following work.

**Example 4.** Find the resultant of the system shown in Figure 8.7a.

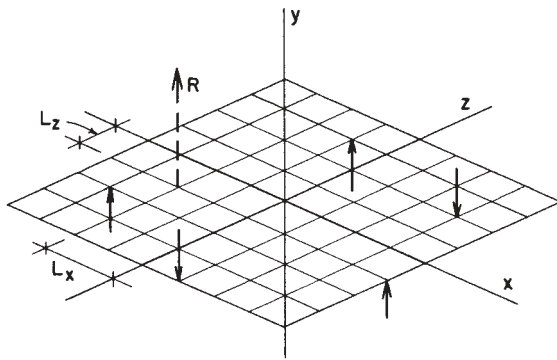
*Solution:* The magnitude of the resultant is found as the simple algebraic sum of the forces. Thus,

$$R = \Sigma F = 50 + 60 + 160 + 80 = 350 \text{ lb}$$

Then, for its location in the  $x$ - $z$  plane:

$$\Sigma M_x = +(160 \times 8) - (60 \times 6) = 920 \text{ ft-lb}$$

$$\Sigma M_z = +(50 \times 8) - (80 \times 15) = 800 \text{ ft-lb}$$



**Figure 8.6** Resultant of a parallel, noncoplanar force system.

and the distances from the axes are

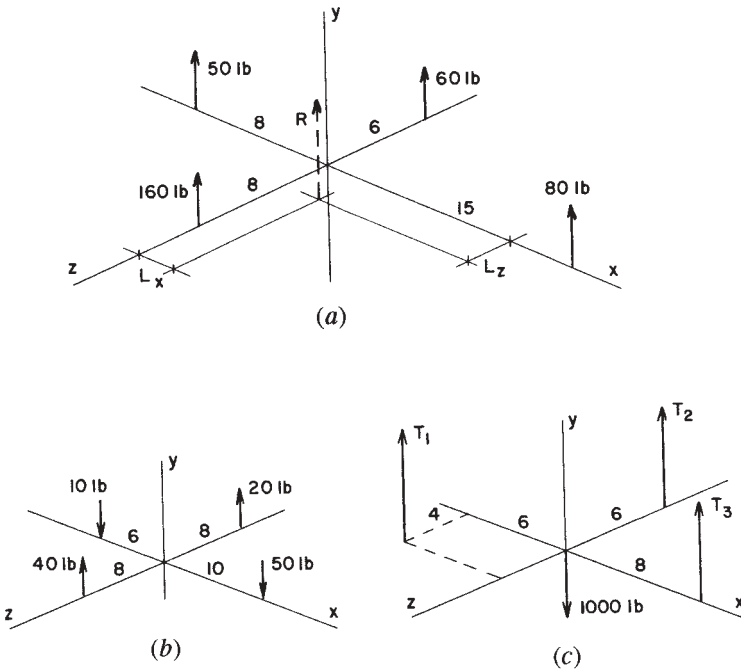
$$L_x = \frac{800}{350} = 2.29 \text{ ft}, \quad L_z = \frac{920}{350} = 2.63 \text{ ft}$$

**Example 5.** Find the resultant of the system shown in Figure 8.7b.

*Solution:* As in the previous example, three summations are made:

$$\begin{aligned} \Sigma F &= R = +40 + 20 - 10 - 50 = 0 \\ \Sigma M_x &= +(40 \times 8) - (20 \times 8) = 160 \text{ ft-lb} \\ \Sigma M_z &= +(10 \times 6) - (50 \times 10) = 440 \text{ ft-lb} \end{aligned}$$

The resultant is seen to be a couple with the two moment components described by the moment summations. If necessary, these two compo-



**Figure 8.7** Examples 4, 5, and 6.

nents can be combined into a single couple about an axis at some angle to the  $x$ -axis or the  $z$ -axis, although it may be sufficient to use the components for some problems.

**Example 6.** Find the tension in the three wires in the system shown in Figure 8.7c.

*Solution:* Using the three static equilibrium equations:

$$\begin{aligned} \Sigma F &= 0 = T_1 + T_2 + T_3 - 1000 \\ \Sigma M_x &= 0 = 4T_1 - 6T_2 \\ \Sigma M_z &= 0 = 6T_1 - 8T_3 \end{aligned}$$

Solution of these three simultaneous equations yields

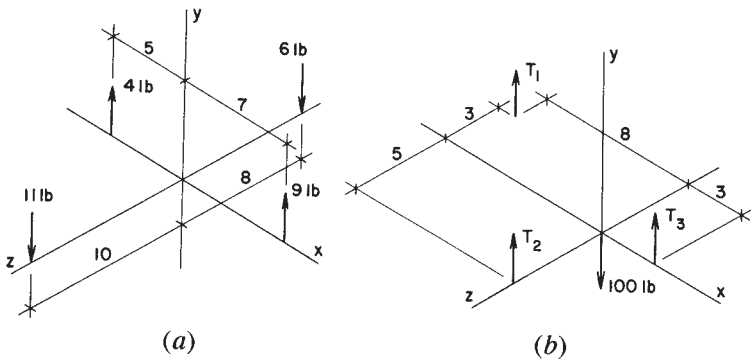
$$T_1 = 414 \text{ lb}, \quad T_2 = 276 \text{ lb}, \quad T_3 = 310 \text{ lb}$$

**Problem 8.2.A**

Find the resultant and its location with respect to the  $x$ - and  $z$ -axes for the system shown in Figure 8.8a.

**Problem 8.2.B**

Find the tension in the three wires of the system shown in Figure 8.8b.



**Figure 8.8** Problems 8.2.A, B.

### 8.3 GENERAL NONCOPLANAR SYSTEMS

This is the general spatial force system with no simplifying conditions regarding geometry. The resultant for such a system may be any of four possibilities, as follows:

1. Zero, if the system is in equilibrium.
2. A force, if the sum of forces is not zero.
3. A couple, if the sum of moments is not zero.
4. A force plus a couple, which is the general case when equilibrium does not exist.

If the resultant is a force, its magnitude is determined as

$$R = \sqrt{(\Sigma F_x)^2 + (\Sigma F_y)^2 + (\Sigma F_z)^2}$$

and its direction by

$$\cos \Theta_x = \frac{\Sigma F_x}{R}, \quad \cos \Theta_y = \frac{\Sigma F_y}{R}, \quad \cos \Theta_z = \frac{\Sigma F_z}{R}$$

If the resultant is a couple, it may be determined in terms of its component moments about the three axes in a procedure similar to that shown for the parallel systems in Section 8.2.

Solution of general spatial force systems is often quite complex and laborious. However, in some situations, the existence of symmetry or other qualifications may simplify the work. In structural design practice, such systems are usually broken down into simpler component systems for investigation and design.

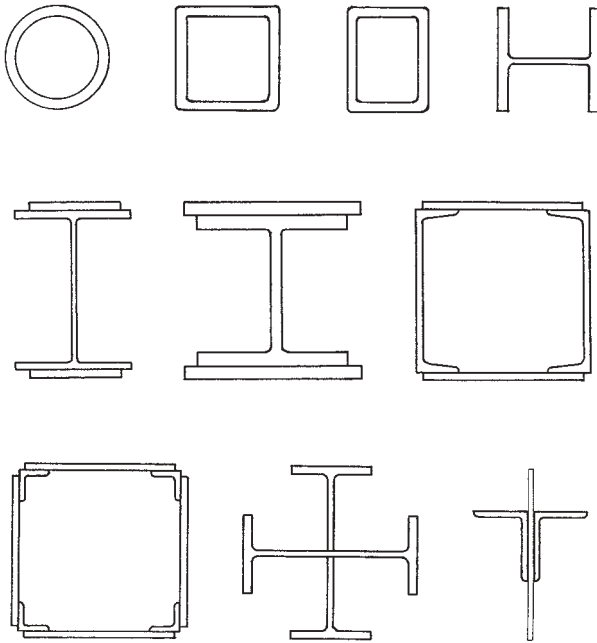
# 9

---

## PROPERTIES OF SECTIONS

---

This chapter deals with various geometric properties of plane (two-dimensional) areas. The areas referred to are the cross-sectional areas of structural members. The geometric properties are used in the analysis of stresses and deformations and in the design of the structural members. Most structural members used for building structures have cross sections that are standardized for the industrial production of products. In the top row in Figure 9.1 are shown four such common shapes, produced from steel and frequently used for building columns: the round pipe, the square or oblong tube, and the I- or H-shape (actually called a W-shape). However, these and other elements are sometimes combined to produce built-up sections, such as those shown in the middle and bottom rows in Figure 9.1. Geometric properties for standard cross sections are tabulated in industry publications, but properties for special sections that are cut from or built up from standard shapes must be computed. This chapter presents some of the basic structural geometric properties and the processes for their computation.



**Figure 9.1** Cross sections for steel compression members. Top row shows common single-piece sections: pipe, tubes, and I-shape (called W-shape). Other sections are combinations of various individual elements. Geometric properties for these planar sections must be obtained for use in the investigation of stresses and strains induced by loading of the structural member.

## 9.1 CENTROIDS

The *center of gravity* of a solid is the imaginary point at which all its weight may be considered to be concentrated or the point through which the resultant weight passes. Since a two-dimensional, planar area has no weight, it has no center of gravity. The point in a plane area that corresponds to the center of gravity of a very thin plate of the same area and shape is called the *centroid* of the area. The centroid is a useful reference for various geometric properties of a planar area.

For example, when a beam is subjected to forces that cause bending, the fibers above a certain plane in the beam are in compression and the

fibers below the plane are in tension. This plane is the *neutral stress plane*, also called simply the *neutral surface* (see Section 11.1). For a cross section of the beam, the intersection of the neutral surface with the plane of the cross section is a line; this line passes through the centroid of the section and is called the *neutral axis* of the beam. The neutral axis is important for investigation of flexural stresses in a beam.

The location of the centroid for symmetrical shapes is usually quite readily apparent. If an area possesses a line (axis) of symmetry, the centroid will be on that line. If there are two distinct lines of symmetry, the centroid will lie at their intersection point. Consider the rectangular area shown in Figure 9.2a; obviously, its centroid is at its geometric center, which is readily determined. This point may be located by measured distances (half the width and half the height) or may be obtained by geometric construction as the intersection of the two diagonals of the rectangle.

(Note: Tables 9.3 through 9.7 and Figure 9.13, referred to in the discussion that follows, are located at the end of this chapter.)

For more complex forms, such as those of rolled steel members (called shapes), the centroid will also lie on any axis of symmetry. Thus, for a W-shape (actually I- or H-shaped), the two bisecting major axes will define the centroid by their intersection. (See reference figure for Table 9.3.) For a channel shape (actually U-shaped), there is only one axis of symmetry (the axis labeled X-X in the reference figure for Table 9.4), and it is therefore necessary to determine the location of the centroid along this line by computation. Given the dimensions of a channel shape, this determination is possible; it is listed as dimension  $x$  in the properties in Table 9.4.

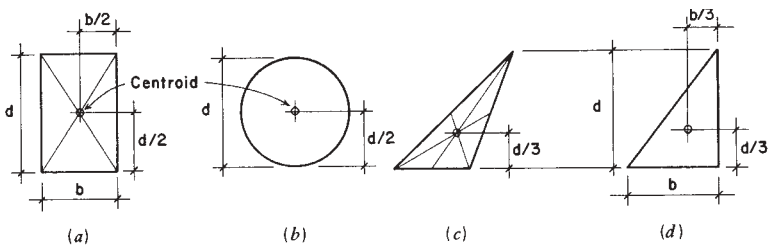


Figure 9.2 Centroids of various planar shapes.



For many structural members, their cross sections are symmetrical about two axes: squares, rectangles, circles, hollow circular cylinders (pipe), and so on. Or, their properties are defined in a reference source, such as the *Manual of Steel Construction* (Ref. 3), from which properties of steel shapes are obtained. However, it is sometimes necessary to determine some geometric properties, such as the centroid, for composite shapes produced by combinations of multiple parts. The process for determining centroids involves the use of the *statical moment*, which is defined as the product of an area times the perpendicular distance of the centroid of the area from a reference axis in the plane of the area. If the area can be reduced to simple components, then its total statical moment can be obtained by summation of the moments of the components. Since this sum is equal to the total area times its centroidal distance from the reference axis, the centroidal distance may be determined by dividing the summation of moments by the total area. As with many geometric postulations, the saying is more difficult than the doing, as the following simple demonstrations will show,

**Example 1.** Figure 9.3 is a beam cross section, unsymmetrical with respect to the horizontal axis (X-X in Figure 9.3c). Find the location of the horizontal centroidal axis for this shape.

**Solution:** The usual process for this problem is to first divide the shape into units for which both the area and centroid of the unit are easily

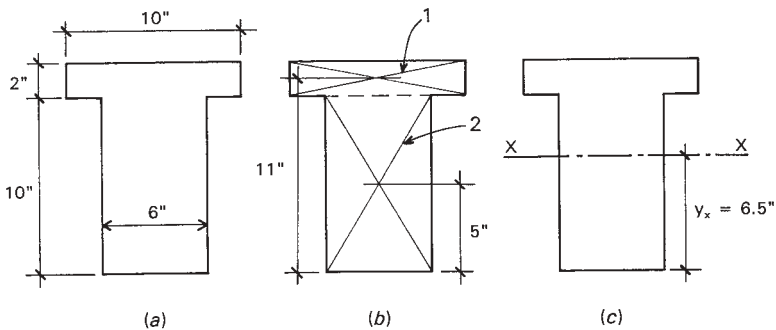


Figure 9.3 Example 1.

**TABLE 9.1 Summary of Computations for Centroid: Example 1**

Part	Area (in. <sup>2</sup> )	$y$ (in.)	$A \times y$ (in. <sup>3</sup> )
1	$2 \times 10 = 20$	11	220
2	$6 \times 10 = 60$	5	300
$\Sigma$	80		520

$$y_x = 520/80 = 6.5 \text{ in.}$$

determined. The division chosen here is shown in Figure 9.3*b*, with two parts labeled 1 and 2.

The second step is to choose an arbitrary reference axis about which to sum statical moments and from which the centroid of the shape is readily measured. A convenient reference axis for this shape is one at either the top or bottom of the shape. With the bottom chosen, the distances from the centroids of the parts to this reference axis are as shown in Figure 9.3*b*.

The computation next proceeds to the determination of the unit areas and the unit statical moments. This work is summarized in Table 9.1, which shows the total area to be 80 in.<sup>2</sup> and the total statical moment to be 520 in.<sup>3</sup>. Dividing the moment by the area produces the value of 6.5 in., which is the distance from the reference axis to the centroid of the whole shape, as shown in Figure 9.3*c*.

### ***Problems 9.1.A–F.***

Find the location of the centroid for the cross-sectional areas shown in Figures 9.4*a–f*. Use the reference axes and indicate the distances from the reference axes to the centroid as  $c_x$  and  $c_y$ , as shown in Figure 9.4*b*.

## **9.2 MOMENT OF INERTIA**

Consider the area enclosed by the irregular line in Figure 9.5*a*. In this area, designated  $A$ , a small unit area  $a$  is indicated at  $z$  distance from the axis marked X-X. If this unit area is multiplied by the square of its distance from the reference axis, the quantity  $a \times z^2$  is defined. If all of the

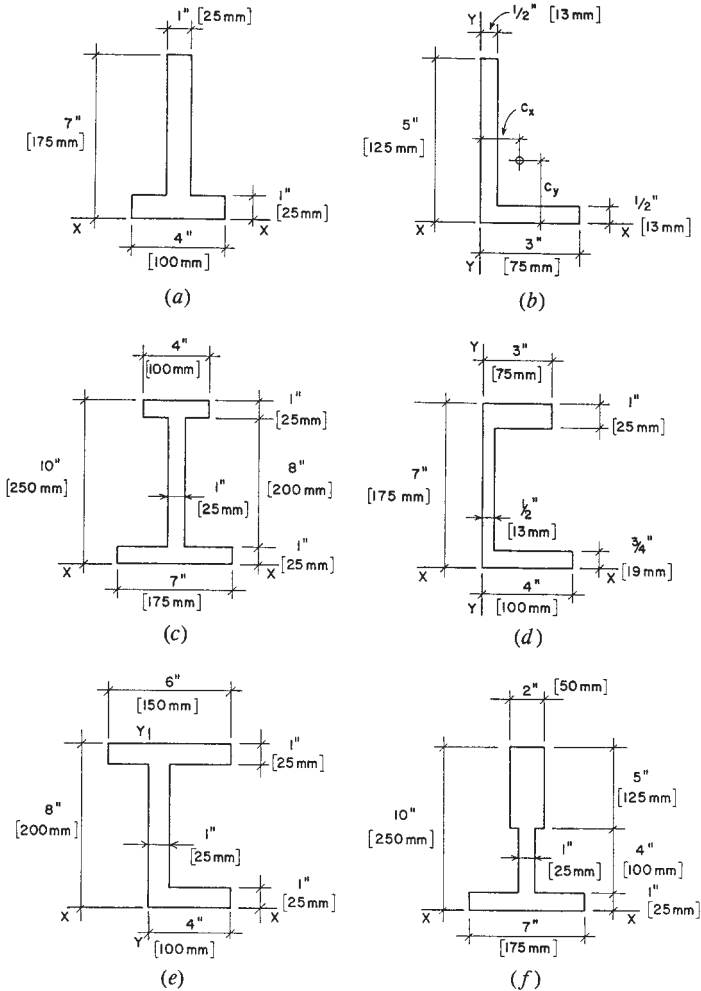


Figure 9.4 Problems 9.1.A–F.

units of the total area are thus identified and the summation of these products is made, the result is defined as the *moment of inertia* or the *second moment* of the area, indicated as  $I$ ; thus,

$$\Sigma az^2 = I, \quad \text{or specifically } I_{X-X}$$

which is identified as the moment of inertia of the area about the X-X axis.

The moment of inertia is a somewhat abstract item, somewhat harder to grasp than the concepts of area, weight, or center of gravity. It is, nevertheless, a real geometric property that becomes an essential factor in investigations for stresses and deformations in structural members. Of particular interest is the moment of inertia about a centroidal axis, and—most significantly—about a principal axis for a shape. Figures 9.5*b, c, e*, and *f* indicate such axes for various shapes.

Inspection of Tables 9.3 through 9.7 will reveal the properties of moment of inertia about the principal axes of the shapes in the tables. Use of these values is demonstrated in various computations in this book.

### Moment of Inertia of Geometric Figures

Values for moments of inertia can often be obtained from tabulations of structural properties. Occasionally, it is necessary to compute values for a given shape. This may be a simple shape, such as a square, rectangular, circular, or triangular area. For such shapes, simple formulas are derived to express the value for the moment of inertia (as they are for area, circumference, etc.).

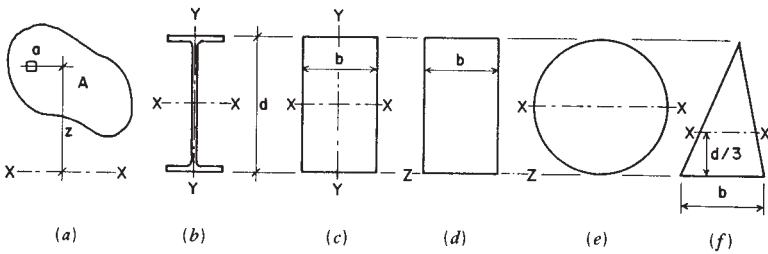
**Squares and Other Rectangles.** Consider the rectangle shown in Figure 9.5*c*. Its width is  $b$  and its depth is  $d$ . The two principal axes are X-X and Y-Y, both passing through the centroid (in this case the simple center) of the area. For this case, the moment of inertia with respect to the centroidal axis X-X is computed as

$$I_{X-X} = \frac{bd^3}{12}$$

and the moment of inertia with respect to the axis Y-Y is

$$I_{Y-Y} = \frac{db^3}{12}$$

**Example 2.** Find the value of the moment of inertia for a  $6 \times 12$ -in. wood beam about an axis through its centroid and parallel to the narrow base of the section.



**Figure 9.5** Consideration of reference axes for the moment of inertia of various shapes of cross sections.

*Solution:* Referring to Table 9.7, the actual dimensions of the section are  $5.5 \times 11.5$  in. Then

$$I = \frac{bd^3}{12} = \frac{(5.5)(11.5)^3}{12} = 697.1 \text{ in.}^4$$

which is in agreement with the value of  $I_{X-X}$  in the table.

**Circles.** Figure 9.5e shows a circular area with diameter  $d$  and axis X-X passing through its center. For the circular area, the moment of inertia is

$$I = \frac{\pi d^4}{64}$$

**Example 3.** Compute the moment of inertia of a circular cross section, 10 in. in diameter, about an axis through its centroid.

*Solution:* The moment of inertia about any axis through the center of the circle is

$$I = \frac{\pi d^4}{64} = \frac{3.1416 \times 10^4}{64} = 490.9 \text{ in.}^4$$

**Triangles.** The triangle in Figure 9.5f has a height  $d$  and base  $b$ . With respect to the base of the triangle, the moment of inertia about the centroidal axis parallel to the base is

$$I = \frac{bd^3}{36}$$

**Example 4.** Assuming that the base of the triangle in Figure 9.5*f* is 12 in. and that the height is 10 in., find the value for the centroidal moment of inertia parallel to the base.

*Solution:* Using the given values in the formula,

$$I = \frac{bd^3}{36} = \frac{12 \times 10^3}{36} = 333.3 \text{ in.}^4$$

**Open and Hollow Shapes.** Values of moment of inertia for shapes that are open or hollow may sometimes be computed by a method of subtraction. This consists of finding the moment of inertia of a solid area—the outer boundary of the area—and subtracting the voided parts. The following examples demonstrate the process. Note that this is possible only for symmetrical shapes.

**Example 5.** Compute the moment of inertia for the hollow box section shown in Figure 9.6*a* about a horizontal axis through the centroid parallel to the narrow side.

*Solution:* Find first the moment of inertia of the shape defined by the outer limits of the box:

$$I = \frac{bd^3}{12} = \frac{6 \times 10^3}{12} = 500 \text{ in.}^4$$

Then find the moment of inertia for the area defined by the void space:

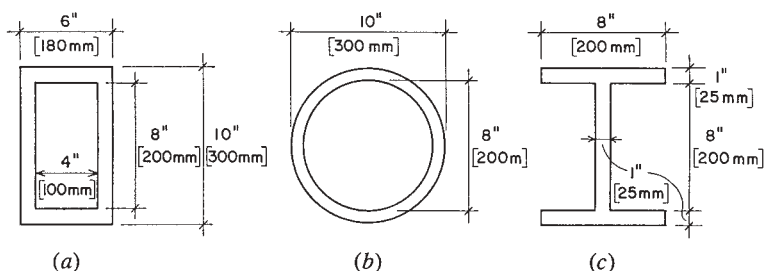
$$I = \frac{4 \times 8^3}{12} = 170.7 \text{ in.}^4$$

The value for the hollow section is the difference; thus,

$$I = 500 - 170.7 = 329.3 \text{ in.}^4$$

**Example 6.** Compute the moment of inertia about an axis through the centroid of the pipe cross section shown in Figure 9.6*b*. The thickness of the shell is 1 in.

*Solution:* As in the preceding example, the two values may be found and subtracted. Alternatively, a single computation may be made as follows:



**Figure 9.6** Examples 5, 6, and 7.

$$\begin{aligned}
 I &= \left(\frac{\pi}{64}\right) \left[ (d_o)^4 - (d_i)^4 \right] \\
 &= \left(\frac{3.1416}{64}\right) (10^4 - 8^4) = 491 - 201 = 290 \text{ in.}^4
 \end{aligned}$$

**Example 7.** Referring to Figure 9.6c, compute the moment of inertia of the I-section about a horizontal axis through the centroid and parallel to the flanges.

*Solution:* This is essentially similar to the computation for Example 5. The two voids may be combined into a single one that is 7-in.-wide; thus,

$$I = \frac{8 \times 10^3}{12} - \frac{7 \times 8^3}{12} = 667 - 299 = 368 \text{ in.}^4$$

Note that this method can only be used when the centroid of the outer shape and the voids coincide. For example, it cannot be used to find the moment of inertia for the I-shaped section in Figure 9.6c about its vertical centroidal axis. For this computation, the method discussed in the following section may be used.

### 9.3 TRANSFERRING MOMENTS OF INERTIA

Determination of the moment of inertia of unsymmetrical and complex shapes cannot be done by the simple processes illustrated in the preceding examples. An additional step that must be used is that involving the

transfer of moment of inertia about a remote axis. The formula for achieving this transfer is as follows:

$$I = I_o + Az^2$$

In this formula,

$I$  = moment of inertia of the cross section about the required reference axis

$I_o$  = moment of inertia of the cross section about its own centroidal axis, parallel to the reference axis

$A$  = area of the cross section

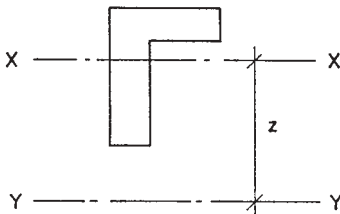
$z$  = distance between the two parallel axes

These relationships are illustrated in Figure 9.7, where X-X is the centroidal axis of the area and Y-Y is the reference axis for the transferred moment of inertia.

Application of this principle is illustrated in the following examples.

**Example 8.** Find the moment of inertia of the T-shaped area in Figure 9.8 about its horizontal (X-X) centroidal axis. (Note: the location of the centroid for this section was solved as Example 1 in Section 9.1.)

*Solution:* A necessary first step in these problems is to locate the position of the centroidal axis if the shape is not symmetrical. In this case, the T-shape is symmetrical about its vertical axis, but not about the horizontal axis. Locating the position of the horizontal axis was the problem solved in Example 1 in Section 9.1.



**Figure 9.7** Transfer of moment of inertia to a parallel axis.



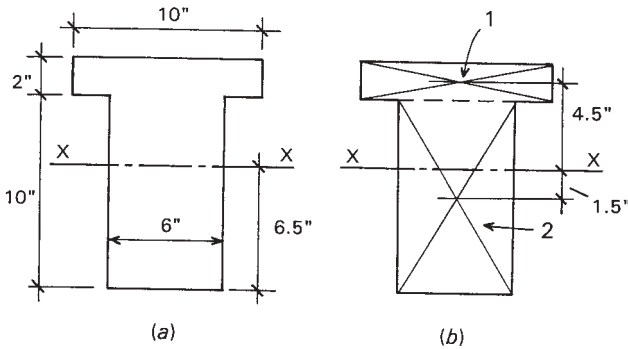


Figure 9.8 Example 8.

The next step is to break the complex shape down into parts for which centroids, areas, and centroidal moments of inertia are readily found. As was done in Example 1, the shape here is divided between the rectangular flange part and the rectangular web part.

The reference axis to be used here is the horizontal centroidal axis. Table 9.2 summarizes the process of determining the factors for the parallel axis transfer process. The required value for  $I$  about the horizontal centroidal axis is determined to be 1046.7 in.<sup>4</sup>.

A common situation in which this problem must be solved is in the case of structural members that are built up from distinct parts. One such section is that shown in Figure 9.9, where a box-shaped cross section is composed by attaching two plates and two rolled channel sections. While this composite section is actually symmetrical about both its principal axes, and the locations of these axes are apparent, the values for moment of inertia about both axes must be determined by the parallel axis transfer process. The following example demonstrates the process.

TABLE 9.2 Summary of Computations for Moment of Inertia: Example 9

Part	Area (in. <sup>2</sup> )	y (in.)	$I_o$ (in. <sup>4</sup> )	$A \times y^2$ (in. <sup>4</sup> )	$I_x$ (in. <sup>4</sup> )
1	20	4.5	$10(2)^3/12 = 6.7$	$20(4.5)^2 = 405$	411.7
2	60	1.5	$6(10)^3/12 = 500$	$60(1.5)^2 = 135$	635
$\Sigma$					<u>1046.7</u>

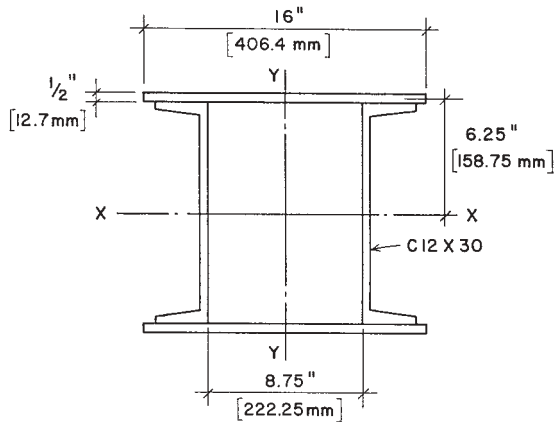


Figure 9.9 Example 9.

**Example 9.** Compute the moment of inertia about the centroidal X-X axis of the built-up section shown in Figure 9.9.

*Solution:* For this situation, the two channels are positioned so that their centroids coincide with the reference axis. Thus, the value of  $I_o$  for the channels is also their actual moment of inertia about the required reference axis, and their contribution to the required value here is simply twice their listed value for moment of inertia about their X-X axis, as given in Table 9.4:  $2(162) = 324 \text{ in.}^4$ .

The plates have simple rectangular cross sections, and the centroidal moment of inertia of one plate is thus determined as

$$I_o = \frac{bd^3}{12} = \frac{16 \times 0.5^3}{12} = 0.1667 \text{ in.}^4$$

The distance between the centroid of the plate and the reference X-X axis is 6.25 in. and the area of one plate is  $8 \text{ in.}^2$ . The moment of inertia for one plate about the reference axis is thus

$$I_o + Az^2 = 0.1667 + (8)(6.25)^2 = 312.7 \text{ in.}^4$$

and the value for the two plates is twice this, or  $625.4 \text{ in.}^4$ .

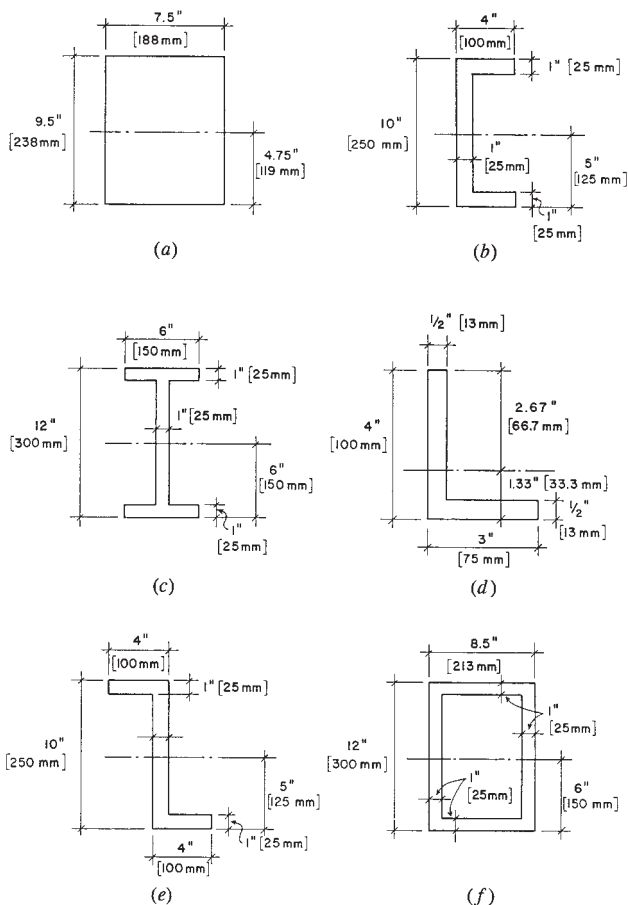
Adding the contributions of the parts, the answer is  $324 + 625.4 = 949.4 \text{ in.}^4$ .

**Problems 9.3.A–F.**

Compute the moments of inertia about the indicated centroidal axes for the cross-sectional shapes in Figure 9.10.

**Problems 9.3.G–I.**

Compute the moments of inertia with respect to the centroidal X–X axes for the built-up sections in Figure 9.11. Make use of any appropriate data from the tables of properties for steel shapes.



**Figure 9.10** Problems 9.3.A–F.

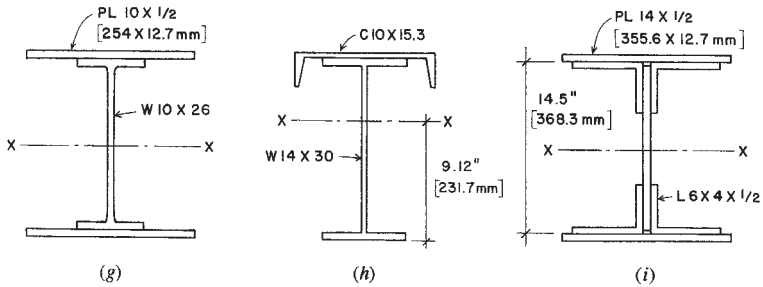


Figure 9.11 Problems 9.3.G–I.

## 9.4 MISCELLANEOUS PROPERTIES

### Section Modulus

As noted in Section 11.2, the term  $I/c$  in the formula for flexural stress is called the *section modulus* (or  $S$ ). Use of the section modulus permits a minor shortcut in the computations for flexural stress or the determination of the bending moment capacity of members. However, the real value of this property is in its measure of relative bending strength of members. As a geometric property, it is a direct index of bending strength for a given member cross section. Members of various cross sections may thus be rank-ordered in terms of their bending strength strictly on the basis of their  $S$  values. Because of its usefulness, the value of  $S$  is listed together with other significant properties in the tabulations for steel and wood members.

For members of standard form (structural lumber and rolled steel shapes), the value of  $S$  may be obtained from tables similar to those presented at the end of this chapter. For complex forms not of standard form, the value of  $S$  must be computed, which is readily done once the centroidal axes are located and moments of inertia about the centroidal axes are determined.

**Example 10.** Verify the tabulated value for the section modulus of a  $6 \times 12$  wood beam about the centroidal axis parallel to its narrow side.

*Solution:* From Table 9.7, the actual dimensions of this member are  $5.5 \times 11.5$  in., and the value for the moment of inertia is  $697.068$  in.<sup>4</sup>. Then,

$$S = \frac{I}{c} = \frac{697.068}{5.75} = 121.229$$

which agrees with the value in Table 9.7.

### Radius of Gyration

For design of slender compression members, an important geometric property is the *radius of gyration*, defined as

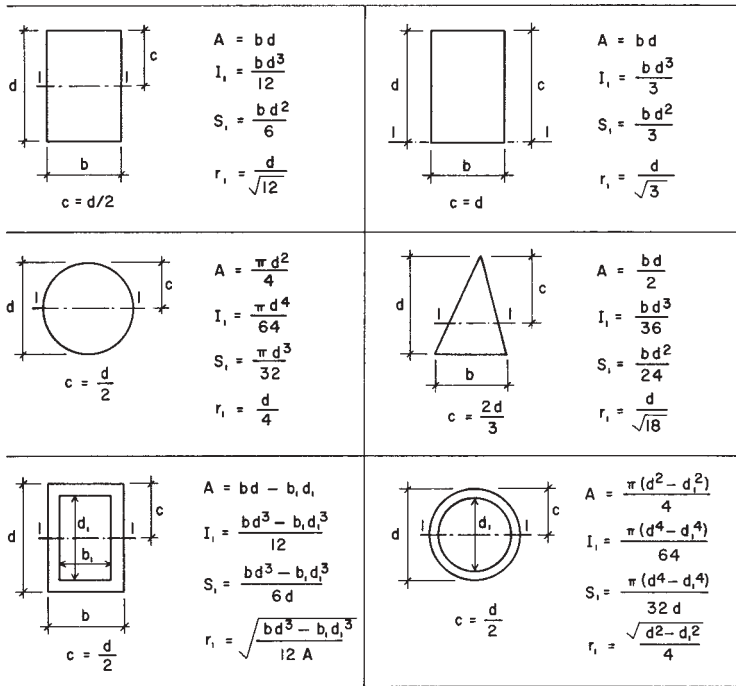
$$r = \sqrt{\frac{I}{A}}$$

Just as with moment of inertia and section modulus values, the radius of gyration has an orientation to a specific axis in the planar cross section of a member. Thus, if the  $I$  used in the formula for  $r$  is that with respect to the X-X centroidal axis, then that is the reference for the specific value of  $r$ .

A value of  $r$  with particular significance is that designated as the *least radius of gyration*. Since this value will be related to the least value of  $I$  for the cross section, and since  $I$  is an index of the bending stiffness of the member, then the least value for  $r$  will indicate the weakest response of the member to bending. This relates specifically to the resistance of slender compression members to buckling. Buckling is essentially a sideways bending response, and its most likely occurrence will be on the axis identified by the least value of  $I$  or  $r$ . Use of these relationships for columns is discussed in Chapter 12.

## 9.5 TABLES OF PROPERTIES OF SECTIONS

Figure 9.12 presents formulas for obtaining geometric properties of various simple plane sections. Some of these may be used for single-piece structural members or for the building up of complex members.



A = Area    I = Moment of inertia    S = Section modulus =  $\frac{I}{c}$     r = Radius of gyration =  $\sqrt{\frac{I}{A}}$

Figure 9.12 Properties of various geometric shapes of cross sections.

Tables 9.3 through 9.7 present the properties of various plane sections. These are sections identified as those of standard industry-produced sections of wood and steel. Standardization means that the shapes and dimensions of the sections are fixed and each specific section is identified in some way.

Structural members may be employed for various purposes, and thus, they may be oriented differently for some structural uses. Of note for any plane section are the *principal axes* of the section. These are the two mutually perpendicular, centroidal axes for which the values will be greatest and least, respectively, for the section; thus, the axes are identified as the major and minor axes. If sections have an axis of symmetry, it will always be a principal axis—either major or minor.

For sections with two perpendicular axes of symmetry (rectangle, H, I, etc.), one axis will be the major axis and the other the minor axis. In the tables of properties, the listed values for  $I$ ,  $S$ , and  $r$  are all identified as to a specific axis, and the reference axes are identified in a figure for the table.

Other values given in the tables are for significant dimensions, total cross-sectional area, and the weight of a 1-ft-long piece of the member. The weight of wood members is given in the table, assuming an average density for structural softwood of 35 lb/ft<sup>3</sup>. The weight of steel members is given for W and channel shapes as part of their designation; thus, a W 8 × 67 member weighs 67 lb/ft. For steel angles and pipes, the weight is given in the table, as determined from the density of steel at 490 lb/ft<sup>3</sup>.

The designation of some members indicates their true dimensions. Thus, a 10-in. channel and a 6-in. angle have true dimensions of 10 and 6 in. For W-shapes, pipe, and structural lumber, the designated dimensions are *nominal*, and the true dimensions must be obtained from the tables.

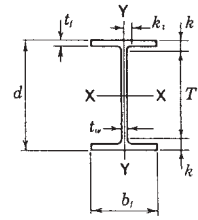


TABLE 9.3 Properties of W-Shapes

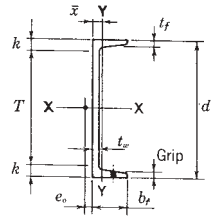
Shape	Area <i>A</i>	Depth <i>d</i>	Web Thickness <i>t<sub>w</sub></i>	Flange			Elastic Properties						Plastic Modulus <i>Z<sub>x</sub></i>
				Width <i>b<sub>f</sub></i>	Thickness <i>t<sub>f</sub></i>	<i>k</i>	Axis X-X			Axis Y-Y			
							<i>I</i>	<i>S</i>	<i>r</i>	<i>I</i>	<i>S</i>	<i>r</i>	
(in. <sup>2</sup> )	(in.)	(in.)	(in.)	(in.)	(in.)	(in.)	(in. <sup>4</sup> )	(in. <sup>3</sup> )	(in.)	(in. <sup>4</sup> )	(in. <sup>3</sup> )	(in.)	(in. <sup>3</sup> )
W 30 × 116	34.2	30.01	0.565	10.495	0.850	1.625	4930.0	329	12.0	164	31.3	2.19	378
× 108	31.7	29.83	0.545	10.475	0.760	1.562	4470	299	11.9	146	27.9	2.15	346
× 99	29.1	29.65	0.520	10.450	0.670	1.437	3990	269	11.7	128	24.5	2.10	312
W 27 × 94	27.7	26.92	0.490	9.990	0.745	1.437	3270	243	10.9	124	24.8	2.12	278
× 84	24.8	26.71	0.460	9.960	0.640	1.375	2850	213	10.7	106	21.2	2.07	244
W 24 × 84	24.7	24.10	0.470	9.020	0.770	1.562	2370	196	9.79	94.4	20.9	1.95	224
× 76	22.4	23.92	0.440	8.990	0.680	1.437	2100	176	9.69	82.5	18.4	1.92	200
× 68	20.1	23.73	0.415	8.965	0.585	1.375	1830	154	9.55	70.4	15.7	1.87	177
W 21 × 83	24.3	21.43	0.515	8.355	0.835	1.562	1830	171	8.67	81.4	19.5	1.83	196
× 73	21.5	21.24	0.455	8.295	0.740	1.500	1600	151	8.64	70.6	17.0	1.81	172
× 57	16.7	21.06	0.405	6.555	0.650	1.375	1170	111	8.36	30.6	9.35	1.35	129
× 50	14.7	20.83	0.380	6.530	0.535	1.312	984	94.5	8.18	24.9	7.64	1.30	110
W 18 × 86	25.3	18.39	0.480	11.090	0.770	1.437	1530	166	7.77	175	31.6	2.63	186
× 76	22.3	18.21	0.425	11.035	0.680	1.375	1330	146	7.73	152	27.6	2.61	163
× 60	17.6	18.24	0.415	7.555	0.695	1.375	984	108	7.47	50.1	13.3	1.69	123
× 55	16.2	18.11	0.390	7.530	0.630	1.312	890	98.3	7.41	44.9	11.9	1.67	112
× 50	14.7	17.99	0.355	7.495	0.570	1.250	800	88.9	7.38	40.1	10.7	1.65	101
× 46	13.5	18.06	0.360	6.060	0.605	1.250	712	78.8	7.25	22.5	7.43	1.29	90.7
× 40	11.8	17.90	0.315	6.015	0.525	1.187	612	68.4	7.21	19.1	6.35	1.27	78.4
W 16 × 50	14.7	16.26	0.380	7.070	0.630	1.312	659	81.0	6.68	37.2	10.5	1.59	92.0
× 45	13.3	16.13	0.345	7.035	0.565	1.250	586	72.7	6.65	32.8	9.34	1.57	82.3
× 40	11.8	16.01	0.305	6.995	0.505	1.187	518	64.7	6.63	28.9	8.25	1.57	72.9
× 36	10.6	15.86	0.295	6.985	0.430	1.125	448	56.5	6.51	24.5	7.00	1.52	64.0
W 14 × 216	62.0	15.72	0.980	15.800	1.560	2.250	2660	338	6.55	1030	130	4.07	390
× 176	51.8	15.22	0.830	15.650	1.310	2.000	2140	281	6.43	838	107	4.02	320
× 132	38.8	14.66	0.645	14.725	1.030	1.687	1530	209	6.28	548	74.5	3.76	234
× 120	35.3	14.48	0.590	14.670	0.940	1.625	1380	190	6.24	495	67.5	3.74	212
× 74	21.8	14.17	0.450	10.070	0.785	1.562	796	112	6.04	134	26.6	2.48	126
× 68	20.0	14.04	0.415	10.035	0.720	1.500	723	103	6.01	121	24.2	2.46	115
× 48	14.1	13.79	0.340	8.030	0.595	1.375	485	70.3	5.85	51.4	12.8	1.91	78.4
× 43	12.6	13.66	0.305	7.995	0.530	1.312	428	62.7	5.82	45.2	11.3	1.89	69.6
× 34	10.0	13.98	0.285	6.745	0.455	1.000	340	48.6	5.83	23.3	6.91	1.53	54.6
× 30	8.85	13.84	0.270	6.730	0.385	0.937	291	42.0	5.73	19.6	5.82	1.49	47.3



**TABLE 9.3 (continued)**

Shape	Web		Flange			Elastic Properties						Plastic Modulus $Z_x$	
	Area $A$	Depth $d$	Thickness $t_w$	Width	Thickness	$k$	Axis X-X			Axis Y-Y			
				$b_f$	$t_f$		$I$	$S$	$r$	$I$	$S$		$r$
(in. <sup>2</sup> )	(in.)	(in.)	(in.)	(in.)	(in.)	(in.)	(in. <sup>4</sup> )	(in. <sup>3</sup> )	(in.)	(in. <sup>4</sup> )	(in. <sup>3</sup> )	(in.)	(in. <sup>3</sup> )
W 12 × 136	39.9	13.41	0.790	12.400	1.250	1.937	1240	186	5.58	398	64.2	3.16	214
× 120	35.3	13.12	0.710	12.320	1.105	1.812	1070	163	5.51	345	56.0	3.13	186
× 72	21.1	12.25	0.430	12.040	0.670	1.375	597	97.4	5.31	195	32.4	3.04	108
× 65	19.1	12.12	0.390	12.000	0.605	1.312	533	87.9	5.28	174	29.1	3.02	96.8
× 53	15.6	12.06	0.345	9.995	0.575	1.250	425	70.6	5.23	95.8	19.2	2.48	77.9
× 45	13.2	12.06	0.335	8.045	0.575	1.250	350	58.1	5.15	50.0	12.4	1.94	64.7
× 40	11.8	11.94	0.295	8.005	0.515	1.250	310	51.9	5.13	44.1	11.0	1.93	57.5
× 30	8.79	12.34	0.260	6.520	0.440	0.937	238	38.6	5.21	20.3	6.24	1.52	43.1
× 26	7.65	12.22	0.230	6.490	0.380	0.875	204	33.4	5.17	17.3	5.34	1.51	37.2
W 10 × 88	25.9	10.84	0.605	10.265	0.990	1.625	534	98.5	4.54	179	34.8	2.63	113
× 77	22.6	10.60	0.530	10.190	0.870	1.500	455	85.9	4.49	154	30.1	2.60	97.6
× 49	14.4	9.98	0.340	10.000	0.560	1.312	272	54.6	4.35	93.4	18.7	2.54	60.4
× 39	11.5	9.92	0.315	7.985	0.530	1.125	209	42.1	4.27	45.0	11.3	1.98	46.8
× 33	9.71	9.73	0.290	7.960	0.435	1.062	170	35.0	4.19	36.6	9.20	1.94	38.8
× 19	5.62	10.24	0.250	4.020	0.395	0.812	96.3	18.8	4.14	4.29	2.14	0.874	21.6
× 17	4.99	10.11	0.240	4.010	0.330	0.750	81.9	16.2	4.05	3.56	1.78	0.844	18.7

Source: Adapted from data in the *Manual of Steel Construction*, 8th edition, with permission of the publishers, American Institute of Steel Construction, Chicago, IL. This table is a sample from an extensive set of tables in the reference document.



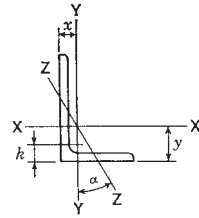
**TABLE 9.4 Properties of American Standard Channels**

Shape	Web			Flange		Elastic Properties								
	Area <i>A</i>	Depth <i>d</i>	Thickness <i>t<sub>w</sub></i>	Width Thickness		<i>k</i>	Axis X-X			Axis Y-Y			<i>x<sup>c</sup></i>	<i>e<sub>o</sub><sup>b</sup></i>
				<i>b<sub>f</sub></i>	<i>t<sub>f</sub></i>		<i>I</i>	<i>S</i>	<i>r</i>	<i>I</i>	<i>S</i>	<i>r</i>		
(in. <sup>2</sup> )	(in.)	(in.)	(in.)	(in.)	(in.)	(in.)	(in. <sup>4</sup> )	(in. <sup>3</sup> )	(in.)	(in. <sup>4</sup> )	(in. <sup>3</sup> )	(in.)	(in.)	(in.)
C 15 × 50	14.7	15.0	0.716	3.716	0.650	1.44	404	53.8	5.24	11.0	3.78	0.867	0.798	0.583
× 40	11.8	15.0	0.520	3.520	0.650	1.44	349	46.5	5.44	9.23	3.37	0.886	0.777	0.767
× 33.9	9.96	15.0	0.400	3.400	0.650	1.44	315	42.0	5.62	8.13	3.11	0.904	0.787	0.896
C 12 × 30	8.82	12.0	0.510	3.170	0.501	1.13	162	27.0	4.29	5.14	2.06	0.763	0.674	0.618
× 25	7.35	12.0	0.387	3.047	0.501	1.13	144	24.1	4.43	4.47	1.88	0.780	0.674	0.746
× 20.7	6.09	12.0	0.282	2.942	0.501	1.13	129	21.5	4.61	3.88	1.73	0.799	0.698	0.870
C 10 × 30	8.82	10.0	0.673	3.033	0.436	1.00	103	20.7	3.42	3.94	1.65	0.669	0.649	0.369
× 25	7.35	10.0	0.526	2.886	0.436	1.00	91.2	18.2	3.52	3.36	1.48	0.676	0.617	0.494
× 20	5.88	10.0	0.379	2.739	0.436	1.00	78.9	15.8	3.66	2.81	1.32	0.692	0.606	0.637
× 15.3	4.49	10.0	0.240	2.600	0.436	1.00	67.4	13.5	3.87	2.28	1.16	0.713	0.634	0.796
C 9 × 20	5.88	9.0	0.448	2.648	0.413	0.94	60.9	13.5	3.22	2.42	1.17	0.642	0.583	0.515
× 15	4.41	9.0	0.285	2.485	0.413	0.94	51.0	11.3	3.40	1.93	1.01	0.661	0.586	0.682
× 13.4	3.94	9.0	0.233	2.433	0.413	0.94	47.9	10.6	3.48	1.76	0.962	0.669	0.601	0.743
C 8 × 18.75	5.51	8.0	0.487	2.527	0.390	0.94	44.0	11.0	2.82	1.98	1.01	0.599	0.565	0.431
× 13.75	4.04	8.0	0.303	2.343	0.390	0.94	36.1	9.03	2.99	1.53	0.854	0.615	0.553	0.604
× 11.5	3.38	8.0	0.220	2.260	0.390	0.94	32.6	8.14	3.11	1.32	0.781	0.625	0.571	0.697
C 7 × 14.75	4.33	7.0	0.419	2.299	0.366	0.88	27.2	7.78	2.51	1.38	0.779	0.564	0.532	0.441
× 12.25	3.60	7.0	0.314	2.194	0.366	0.88	24.2	6.93	2.60	1.17	0.703	0.571	0.525	0.538
× 9.8	2.87	7.0	0.210	2.090	0.366	0.88	21.3	6.08	2.72	0.968	0.625	0.581	0.540	0.647
C 6 × 13	3.83	6.0	0.437	2.157	0.343	0.81	17.4	5.80	2.13	1.05	0.642	0.525	0.514	0.380
× 10.5	3.09	6.0	0.314	2.034	0.343	0.81	15.2	5.06	2.22	0.866	0.564	0.529	0.499	0.486
× 8.2	2.40	6.0	0.200	1.920	0.343	0.81	13.1	4.38	2.34	0.693	0.492	0.537	0.511	0.599

Source: Adapted from data in the *Manual of Steel Construction*, 8th edition, with permission of the publishers, American Institute of Steel Construction, Chicago, IL. This table is a sample from an extensive set of tables in the reference document.

<sup>a</sup>Distance to centroid of section.

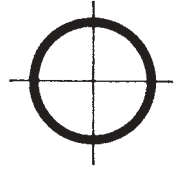
<sup>b</sup>Distance to shear center of section.



**TABLE 9.5 Properties of Single-Angle Shapes**

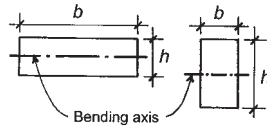
Size and Thickness (in.)	Weight per ft (lb)	Area (in. <sup>2</sup> )	Axis X-X				Axis Y-Y				Axis Z-Z		
			<i>I</i> (in. <sup>4</sup> )	<i>S</i> (in. <sup>3</sup> )	<i>r</i> (in.)	<i>y</i> (in.)	<i>I</i> (in. <sup>4</sup> )	<i>S</i> (in. <sup>3</sup> )	<i>r</i> (in.)	<i>x</i> (in.)	<i>r</i> (in.)	tan α	
8 × 8 × 1 1/8	1.75	56.9	16.7	98.0	17.5	2.42	2.41	98.0	17.5	2.42	2.41	1.56	1.000
× 1	1.62	51.0	15.0	89.0	15.8	2.44	2.37	89.0	15.8	2.44	2.37	1.56	1.000
8 × 6 × 3/4	1.25	33.8	9.94	63.4	11.7	2.53	2.56	30.7	6.92	1.76	1.56	1.29	0.551
× 1/2	1.00	23.0	6.75	44.3	8.02	2.56	2.47	21.7	4.79	1.79	1.47	1.30	0.558
6 × 6 × 5/8	1.12	24.2	7.11	24.2	5.66	1.84	1.73	24.2	5.66	1.84	1.73	1.18	1.000
× 1/2	1.00	19.6	5.75	19.9	4.61	1.86	1.68	19.9	4.61	1.86	1.68	1.18	1.000
6 × 4 × 5/8	1.12	20.0	5.86	21.1	5.31	1.90	2.03	7.52	2.54	1.13	1.03	0.864	0.435
× 1/2	1.00	16.2	4.75	17.4	4.33	1.91	1.99	6.27	2.08	1.15	0.987	0.870	0.440
× 3/8	0.87	12.3	3.61	13.5	3.32	1.93	1.94	4.90	1.60	1.17	0.941	0.877	0.446
5 × 3 1/2 × 1/2	1.00	13.6	4.00	9.99	2.99	1.58	1.66	4.05	1.56	1.01	0.906	0.755	0.479
× 3/8	0.87	10.4	3.05	7.78	2.29	1.60	1.61	3.18	1.21	1.02	0.861	0.762	0.486
5 × 3 × 1/2	1.00	12.8	3.75	9.45	2.91	1.59	1.75	2.58	1.15	0.829	0.750	0.648	0.357
× 3/8	0.87	9.8	2.86	7.37	2.24	1.61	1.70	2.04	0.888	0.845	0.704	0.654	0.364
4 × 4 × 1/2	0.87	12.8	3.75	5.56	1.97	1.22	1.18	5.56	1.97	1.22	1.18	0.782	1.000
× 3/8	0.75	9.8	2.86	4.36	1.52	1.23	1.14	4.36	1.52	1.23	1.14	0.788	1.000
4 × 3 × 1/2	0.94	11.1	3.25	5.05	1.89	1.25	1.33	2.42	1.12	0.864	0.827	0.639	0.543
× 3/8	0.81	8.5	2.48	3.96	1.46	1.26	1.28	1.92	0.866	0.879	0.782	0.644	0.551
× 1/16	0.75	7.2	2.09	3.38	1.23	1.27	1.26	1.65	0.734	0.887	0.759	0.647	0.554
3 1/2 × 3 1/2 × 3/8	0.75	8.5	2.48	2.87	1.15	1.07	1.01	2.87	1.15	1.07	1.01	0.687	1.000
× 3/16	0.69	7.2	2.09	2.45	0.976	1.08	0.990	2.45	0.976	1.08	0.990	0.690	1.000
3 1/2 × 2 1/2 × 3/8	0.81	7.2	2.11	2.56	1.09	1.10	1.16	1.09	0.592	0.719	0.650	0.537	0.496
× 3/16	0.75	6.1	1.78	2.19	0.927	1.11	1.14	0.939	0.504	0.727	0.637	0.540	0.501
3 × 3 × 3/8	0.69	7.2	2.11	1.76	0.833	0.913	0.888	1.76	0.833	0.913	0.888	0.587	1.000
× 3/16	0.62	6.1	1.78	1.51	0.707	0.922	0.865	1.51	0.707	0.922	0.865	0.589	1.000
3 × 2 1/2 × 3/8	0.75	6.6	1.92	1.66	0.810	0.928	0.956	1.04	0.581	0.736	0.706	0.522	0.676
× 3/16	0.69	5.6	1.62	1.42	0.688	0.937	0.933	0.898	0.494	0.744	0.683	0.525	0.680
3 × 2 × 3/8	0.69	5.9	1.73	1.53	0.781	0.940	1.04	0.543	0.371	0.559	0.539	0.430	0.428
× 3/16	0.62	5.0	1.46	1.32	0.664	0.948	1.02	0.470	0.317	0.567	0.516	0.432	0.435
2 1/2 × 2 1/2 × 3/8	0.69	5.9	1.73	0.984	0.566	0.753	0.762	0.984	0.566	0.753	0.762	0.487	1.000
× 3/16	0.62	5.0	1.46	0.849	0.482	0.761	0.740	0.849	0.482	0.761	0.740	0.489	1.000
2 1/2 × 2 × 3/8	0.69	5.3	1.55	0.912	0.547	0.768	0.831	0.514	0.363	0.577	0.581	0.420	0.614
× 3/16	0.62	4.5	1.31	0.788	0.466	0.776	0.809	0.446	0.310	0.584	0.559	0.422	0.620

Source: Adapted from data in the *Manual of Steel Construction*, 8th edition, with permission of the publishers, American Institute of Steel Construction, Chicago, IL. This table is a sample from an extensive set of tables in the reference document.

**TABLE 9.6 Properties of Standard Weight Steel Pipe**

Nominal Diameter (in.)	Dimensions			Weight per ft (lb)	Properties			
	Outside Diameter (in.)	Inside Diameter (in.)	Wall Thickness (in.)		$A$ (in. <sup>2</sup> )	$I$ (in. <sup>4</sup> )	$S$ (in. <sup>3</sup> )	$r$ (in.)
½	0.840	0.622	0.109	0.85	0.250	0.017	0.041	0.261
¾	1.050	0.824	0.113	1.13	0.333	0.037	0.071	0.334
1	1.315	1.049	0.133	1.68	0.494	0.087	0.133	0.421
1¼	1.660	1.380	0.140	2.27	0.669	0.195	0.235	0.540
1½	1.900	1.610	0.145	2.72	0.799	0.310	0.326	0.623
2	2.375	2.067	0.154	3.65	1.07	0.666	0.561	0.787
2½	2.875	2.469	0.203	5.79	1.70	1.53	1.06	0.947
3	3.500	3.068	0.216	7.58	2.23	3.02	1.72	1.16
3½	4.000	3.548	0.226	9.11	2.68	4.79	2.39	1.34
4	4.500	4.026	0.237	10.79	3.17	7.23	3.21	1.51
5	5.563	5.047	0.258	14.62	4.30	15.2	5.45	1.88
6	6.625	6.065	0.280	18.97	5.58	28.1	8.50	2.25
8	8.625	7.981	0.322	28.55	8.40	72.5	16.8	2.94
10	10.750	10.020	0.365	40.48	11.9	161	29.9	3.67
12	12.750	12.000	0.375	49.56	14.6	279	43.8	4.38

Source: Adapted from data in the *Manual of Steel Construction*, 8th edition, with permission of the publishers, American Institute of Steel Construction, Chicago, IL. This table is a sample from an extensive set of tables in the reference document.



**TABLE 9.7 Properties of Structural Lumber**

Dimensions (in.)		Area <i>A</i> (in. <sup>2</sup> )	Section Modulus <i>S</i> (in. <sup>3</sup> )	Moment of Inertia <i>I</i> (in. <sup>4</sup> )	Weight <sup>a</sup> (lb/ft)
Nominal <i>b</i> × <i>h</i>	Actual <i>b</i> × <i>h</i>				
2 × 3	1.5 × 2.5	3.75	1.563	1.953	0.9
2 × 4	1.5 × 3.5	5.25	3.063	5.359	1.3
2 × 6	1.5 × 5.5	8.25	7.563	20.797	2.0
2 × 8	1.5 × 7.25	10.875	13.141	47.635	2.6
2 × 10	1.5 × 9.25	13.875	21.391	98.932	3.4
2 × 12	1.5 × 11.25	16.875	31.641	177.979	4.1
2 × 14	1.5 × 13.25	19.875	43.891	290.775	4.8
3 × 2	2.5 × 1.5	3.75	0.938	0.703	0.9
3 × 4	2.5 × 3.5	8.75	5.104	8.932	2.1
3 × 6	2.5 × 5.5	13.75	12.604	34.661	3.3
3 × 8	2.5 × 7.25	18.125	21.901	79.391	4.4
3 × 10	2.5 × 9.25	23.125	35.651	164.886	5.6
3 × 12	2.5 × 11.25	28.125	52.734	296.631	6.8
3 × 14	2.5 × 13.25	33.125	73.151	484.625	8.1
3 × 16	2.5 × 15.25	38.125	96.901	738.870	9.3
4 × 2	3.5 × 1.5	5.25	1.313	0.984	1.3
4 × 3	3.5 × 2.5	8.75	3.646	4.557	2.1
4 × 4	3.5 × 3.5	12.25	7.146	12.505	3.0
4 × 6	3.5 × 5.5	19.25	17.646	48.526	4.7
4 × 8	3.5 × 7.25	25.375	30.661	111.148	6.2
4 × 10	3.5 × 9.25	32.375	49.911	230.840	7.9
4 × 12	3.5 × 11.25	39.375	73.828	415.283	9.6
4 × 14	3.5 × 13.25	46.375	102.411	678.475	11.3
4 × 16	3.5 × 15.25	53.375	135.661	1034.418	13.0
6 × 2	5.5 × 1.5	8.25	2.063	1.547	2.0
6 × 3	5.5 × 2.5	13.75	5.729	7.161	3.3
6 × 4	5.5 × 3.5	19.25	11.229	19.651	4.7
6 × 6	5.5 × 5.5	30.25	27.729	76.255	7.4
6 × 10	5.5 × 9.5	52.25	82.729	392.963	12.7
6 × 12	5.5 × 11.5	63.25	121.229	697.068	15.4

TABLE 9.7 (Continued)

Dimensions (in.)		Area A (in. <sup>2</sup> )	Section Modulus S (in. <sup>3</sup> )	Moment of Inertia I (in. <sup>4</sup> )	Weight <sup>a</sup> (lb/ft)
Nominal <i>b</i> × <i>h</i>	Actual <i>b</i> × <i>h</i>				
6 × 14	5.5 × 13.5	74.25	167.063	1127.672	18.0
6 × 16	5.5 × 15.5	85.25	220.229	1706.776	20.7
8 × 2	7.25 × 1.5	10.875	2.719	2.039	2.6
8 × 3	7.25 × 2.5	18.125	7.552	9.440	4.4
8 × 4	7.25 × 3.5	25.375	14.802	25.904	6.2
8 × 6	7.5 × 5.5	41.25	37.813	103.984	10.0
8 × 8	7.5 × 7.5	56.25	70.313	263.672	13.7
8 × 10	7.5 × 9.5	71.25	112.813	535.859	17.3
8 × 12	7.5 × 11.5	86.25	165.313	950.547	21.0
8 × 14	7.5 × 13.5	101.25	227.813	1537.734	24.6
8 × 16	7.5 × 15.5	116.25	300.313	2327.422	28.3
8 × 18	7.5 × 17.5	131.25	382.813	3349.609	31.9
8 × 20	7.5 × 19.5	146.25	475.313	4634.297	35.5
10 × 10	9.5 × 9.5	90.25	142.896	678.755	21.9
10 × 12	9.5 × 11.5	109.25	209.396	1204.026	26.6
10 × 14	9.5 × 13.5	128.25	288.563	1947.797	31.2
10 × 16	9.5 × 15.5	147.25	380.396	2948.068	35.8
10 × 18	9.5 × 17.5	166.25	484.896	4242.836	40.4
10 × 20	9.5 × 19.5	185.25	602.063	5870.109	45.0
12 × 12	11.5 × 11.5	132.25	253.479	1457.505	32.1
12 × 14	11.5 × 13.5	155.25	349.313	2357.859	37.7
12 × 16	11.5 × 15.5	178.25	460.479	3568.713	43.3
12 × 18	11.5 × 17.5	201.25	586.979	5136.066	48.9
12 × 20	11.5 × 19.5	224.25	728.813	7105.922	54.5
12 × 22	11.5 × 21.5	247.25	885.979	9524.273	60.1
12 × 24	11.5 × 23.5	270.25	1058.479	12437.129	65.7
14 × 14	13.5 × 13.5	182.25	410.063	2767.922	44.3
16 × 16	15.5 × 15.5	240.25	620.646	4810.004	58.4

Source: Compiled from data in the *National Design Specification for Wood Construction*, 1982 ed., with permission of the publishers, National Forest Products Association, Washington, DC.

<sup>a</sup>Based on an assumed average density of 35 psf.

# 10

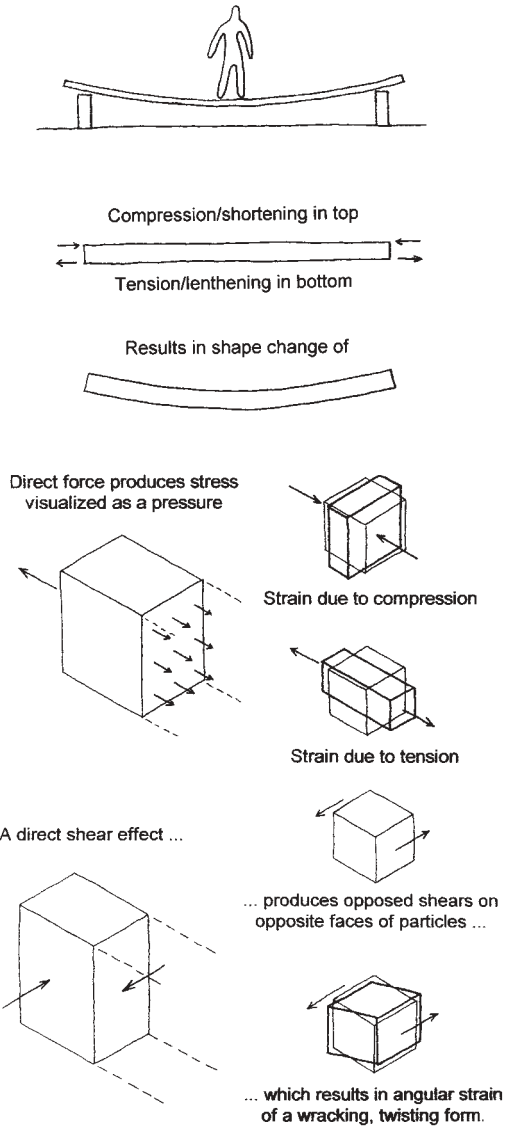
---

## STRESS AND DEFORMATION

---

Structural actions develop stresses in the material of a structure and accompanying shape changes, or deformations (see Figure 10.1). Simple forces of compression and tension produce corresponding direct stresses of compression or tension in the material, and accompanying shortening or lengthening as shape changes. Shear produces a slipping type of stress and an angular change as deformation. All other force actions and combinations of actions produce some combination of these three basic types of stress: compression, tension, and shear. For example, bending produces a combination of opposed compression and tension in the affected structural member, the accumulation of which over the member's length results in curvature of the member.

This chapter presents some basic considerations for the structural behavior of materials.



**Figure 10.1** Force actions produce stresses in the materials of a structure. These incremental stresses accumulate to achieve overall deformations of structures, such as the deflection of beams.



## 10.1 MECHANICAL PROPERTIES OF MATERIALS

Stresses are visualized as unit stresses and are measured in terms of force per unit area. The unit area is usually an increment of the area of a cross section of a structural member, and the force is that required to be developed at the cross section. Thus, in Figure 10.2*a*, the force of 6400 lb produces a unit stress of 100 psi on the 64 in.<sup>2</sup> of the cross section of the post. In a similar manner, it can be determined that the tension force of the 1500-lb block in Figure 10.2*c* produces a tension stress of 7653 psi in the 1/2-in. diameter rod.

Direct shear actions can also be treated in this manner. Thus, if the bolt in Figure 10.2*d* is 3/4-in. in diameter and is subjected to a force of 5000 lb, as shown, the direct slicing shear stress will be 11,317 psi.

In these situations, the relationship between the force, the area of the cross section, and the unit stress may be stated in general terms as

$$P = f \times A \quad \text{or} \quad f = \frac{P}{A} \quad \text{or} \quad A = \frac{P}{f}$$

in which

$P$  = axial direct force in pounds, newtons, and so on,

$f$  = unit stress in pounds per square inch (psi), and so on,

$A$  = area of the stressed cross section in units of in.<sup>2</sup>, and so on.

The first form of the stress equation is used to determine the capacity of a member with a given cross section and a specific limiting stress. The second form is used to investigate a stress condition for a given member under a specified load. The third form is used directly in design work to determine the required cross-sectional area for a member with a limiting stress and a required load.

### Deformation

Whenever a force acts on a body, there is an accompanying change in shape or size of the body. In structural mechanics, this is called *deformation*. Regardless of the magnitude of the force, some deformation is always present, although often it is so small that it is difficult to measure even with the most sensitive instruments. In the design of structures, it is

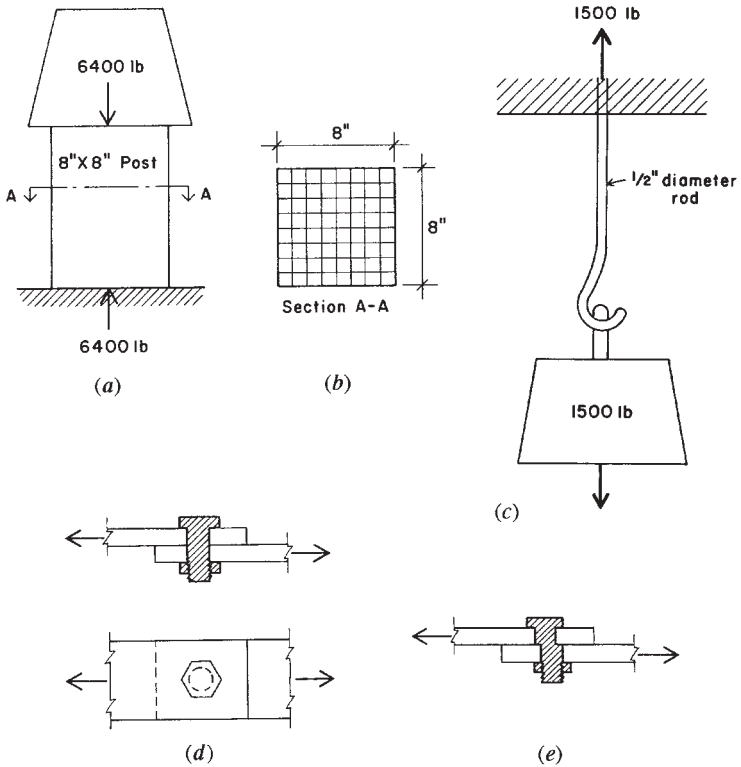


Figure 10.2 Direct force action and stress.

often necessary to know what the deformation in certain members will be. A floor joist, for instance, may be large enough to support a given load safely but may *deflect* (the term for deformation that occurs with bending) to such an extent that the plaster ceiling below it will crack, or the floor may feel excessively springy to persons walking on it. For the usual cases, we can readily determine what the deformation will be. This is considered in more detail later.

### Strength

The *strength* of a material or a structural member is the measure of its capacity to resist force. Strength of a material may be expressed in terms of

its resistance to the three basic stresses: compression, tension, and shear. Strength of a structural member may be expressed in terms of its resistance to a particular structural action, such as direct compression, direct tension, bending, and so on.

## 10.2 DESIGN USE OF DIRECT STRESS

In the examples and problems dealing with the direct stress equation, differentiation was made between the unit stress developed in a member sustaining a given load ( $f = P/A$ ) and the *allowable unit stress* used when determining the size of a member required to carry a given load ( $A = P/f$ ). The latter form of the equation is, of course, the one used in design. The procedures for establishing allowable unit stresses in tension, compression, shear, and bending are different for different materials and are prescribed in industry-prepared specifications. A sample of data from such references is presented in Table 10.1.

In actual design work, the building code governing the construction of buildings in the particular locality must be consulted for specific requirements. Many municipal codes are revised infrequently and, consequently, may not be in agreement with current editions of the industry recommended allowable stresses.

**TABLE 10.1 Selected Values for Common Structural Materials**

Material and Property	Common Values	
	psi	kPa
<i>Structural Steel</i>		
Yield strength	36,000	248,220
Allowable tension	22,000	151,690
Modulus of elasticity, $E$	29,000,000	200,000,000
<i>Concrete</i>		
$f'_c$ (specified compressive strength)	3,000	20,685
Usable compression in bearing	900	6,206
Modulus of elasticity, $E$	3,100,000	21,374,500
<i>Structural Lumber (Douglas Fir–Larch, Select Structural Grade, Posts and Timbers)</i>		
Compression, parallel to grain	1,150	7,929
Modulus of elasticity, $E$	1,600,000	11,032,000

Except for shear, the stresses discussed so far have been direct or axial stresses. This means they are assumed to be uniformly distributed over the cross section. The examples and problems presented fall under three general types: first, the design of structural members ( $A = P/f$ ); second, the determination of safe loads ( $P = fA$ ); third, the investigation of members for safety ( $f = P/A$ ). The following examples will serve to fix in mind each of these types.

**Example 1.** Design (determine the size of) a short, square post of Douglas fir, select structural grade, to carry a compressive load of 30,000 lb [133,440 N].

*Solution:* Referring to Table 10.1, the allowable unit compressive stress for this wood parallel to the grain is 1150 psi [7929 kPa]. The required area of the post is

$$A = \frac{P}{f} = \frac{30,000}{1150} = 26.09 \text{ in.}^2 [16,829 \text{ mm}^2]$$

From Table 9.7, an area of 30.25 in.<sup>2</sup> [19,517 mm<sup>2</sup>] is provided by a 6 × 6 in. post with a dressed size of 5½ × 5½ in. [139.7 mm].

**Example 2.** Determine the safe axial compressive load for a short, square concrete pier with a side dimension of 2 ft [0.6096 m].

*Solution:* The area of the pier is 4 ft<sup>2</sup> or 576 in.<sup>2</sup> [0.3716 m<sup>2</sup>]. Table 10.1 gives the allowable unit compressive stress for concrete as 900 psi [6206 kPa]. Therefore the safe load on the pier is

$$P = (f)(A) = (900)(576) = 528,400 \text{ lb [206 kN]}$$

**Example 3.** A running track in a gymnasium is hung from the roof trusses by steel rods, each of which supports a tensile load of 11,200 lb [49,818 N]. The round rods have a diameter of 7/8 in. [22.23 mm] with the ends *upset*, that is, made larger by forging. This upset allows the full cross-sectional area of the rod (0.601 in.<sup>2</sup>) [388 mm<sup>2</sup>] to be utilized; otherwise the cutting of the threads will reduce the cross section of the rod. Investigate this design to determine whether it is safe.

*Solution.* Since the gross area of the hanger rod is effective, the unit stress developed is

$$f = \frac{P}{A} = \frac{11,200}{0.601} = 18,636 \text{ psi [128,397 kPa]}$$

Table 10.1 gives the allowable unit tensile stress for steel as 22,000 psi [151,690 kPa], which is greater than that developed by the loading. Therefore, the design is safe.

### Shearing Stress Formula

The foregoing manipulations of the direct stress formula can, of course, be carried out also with the shearing stress formula  $f_v = P/A$ . However, it must be borne in mind that the shearing stress acts transversely to the cross section—not at right angles to it. Furthermore, while the shearing stress equation applies directly to the situation illustrated by Figures 10.2*d* and *e*, it requires modification for application to beams. The latter situation is considered in more detail in Section 11.5.

#### **Problem 10.2.A**

What should be the minimum cross-sectional area of a steel rod to support a tensile load of 26 kips [115,648 kN]?

#### **Problem 10.2.B**

A short, square post of Douglas fir, select structural grade, is to support an axial load of 61 kips [271.3 kN]. What should its nominal dimensions be?

#### **Problem 10.2.C**

A steel rod has a diameter of 1.25 in. [31.75 mm]. What safe tensile load will it support if its ends are upset?

#### **Problem 10.2.D**

What safe load will a short, 12 × 12 in. [actually 292.1 mm] Douglas fir post support if the grade of the wood is select structural grade?

#### **Problem 10.2.E**

A short post of Douglas fir, select structural grade, with nominal dimensions of 6 × 8 in. [actually 139.7 × 190.5 mm] supports an axial load of 50 kips [222.4 kN]. Investigate this design to determine whether it is safe.

**Problem 10.2.F**

A short concrete pier, 1 ft 6 in. [457.2 mm] square, supports an axial load of 150 kips [667.2 kN]. Is the construction safe?

**10.3 DEFORMATION AND STRESS: RELATIONS AND ISSUES**

Stress is a major issue, primarily for determination of the strength of structures. However, deformation due to stress is often of concern, and the relation of stress to strain is one that must be quantitatively established. These relations and the issues they raise are discussed in this section.

**Hooke's Law**

As a result of experiments with clock springs, Robert Hooke, a mathematician and physicist working in the seventeenth century, developed the theory that “deformations are directly proportional to stresses.” In other words, if a force produces a certain deformation, twice the force will produce twice the amount of deformation. This law of physics is of utmost importance in structural engineering although, as we shall find, Hooke's law holds true only up to a certain limit.

**Elastic Limit and Yield Point**

Suppose that a bar of structural steel with a cross-sectional area of 1 in.<sup>2</sup> is placed into a machine for making tension tests. Its length is accurately measured and then a tensile force of 5000 lb is applied, which, of course, produces a unit tensile stress of 5000 psi in the bar. Measuring the length again, it is found that the bar has lengthened a definite amount, call it  $x$  inches. On applying 5000 lb more, the amount of lengthening is now  $2(x)$ , or twice the amount noted after the first 5000 lb. If the test is continued, it will be found that for each 5000 lb increment of additional load, the length of the bar will increase the same amount as noted when the initial 5000 lb was applied; that is, the deformations (length changes) are directly proportional to the stresses. So far Hooke's law has held true, but when a unit stress of about 36,000 psi is reached, the length increases more than  $x$  for each additional 5000 lb of load. This unit stress is called the *elastic limit*, or the *yield stress*. Beyond this stress limit, Hooke's law will no longer apply.

Another phenomenon may be noted in this connection. In the test just described, it will be observed that, when any applied load that produces a unit stress *less* than the elastic limit is removed, the bar returns to its original length. If the load producing a unit stress *greater* than the elastic limit is removed, it will be found that the bar has permanently increased its length. This permanent deformation is called the *permanent set*. This fact permits another way of defining the elastic limit: it is that unit stress beyond which the material does not return to its original length when the load is removed.

If this test is continued beyond the elastic limit, a point is reached where the deformation increases without any increase in the load. The unit stress at which this deformation occurs is called the *yield point*; it has a value only slightly higher than the elastic limit. Since the yield point, or yield stress, as it is sometimes called, can be determined more accurately by test than the elastic limit, it is a particularly important unit stress. Nonductile materials such as wood and cast iron have poorly defined elastic limits and no yield point.

### Ultimate Strength

After passing the yield point, the steel bar of the test described in the preceding discussion again develops resistance to the increasing load. When the load reaches a sufficient magnitude, rupture occurs. The unit stress in the bar just before it breaks is called the *ultimate strength*. For the grade of steel assumed in the test, the ultimate strength may occur at a stress as high as about 80,000 psi.

Structural members are designed so that stresses under normal service conditions will not exceed the elastic limit, even though there is considerable reserve strength between this value and the ultimate strength. This procedure is followed because deformations produced by stresses above the elastic limit are permanent and hence change the shape of the structure in a permanent manner.

### Factor of Safety

The degree of uncertainty that exists, with respect to both actual loading of a structure and uniformity in the quality of materials, requires that some reserve strength be built into the design. This degree of reserve strength is the *factor of safety*. Although there is no general agreement on

the definition of this term, the following discussion will serve to fix the concept in mind.

Consider a structural steel that has an ultimate tensile unit stress of 58,000 psi, a yield-point stress of 36,000 psi, and an allowable stress of 22,000 psi. If the factor of safety is defined as the ratio of the ultimate stress to the allowable stress, its value is  $58,000 \div 22,000$ , or 2.64. On the other hand, if it is defined as the ratio of the yield-point stress to the allowable stress, its value is  $36,000 \div 22,000$ , or 1.64. This is a considerable variation, and since deformation failure of a structural member begins when it is stressed beyond the elastic limit, the higher value may be misleading. Consequently, the term *factor of safety* is not employed extensively today. Building codes generally specify the allowable unit stresses that are to be used in design for the grades of structural steel to be employed.

If one should be required to pass judgment on the safety of a structure, the problem resolves itself into considering each structural element, finding its actual unit stress under the existing loading conditions, and comparing this stress with the allowable stress prescribed by the local building regulations. This procedure is called *structural investigation*.

## Modulus of Elasticity

Within the elastic limit of a material, deformations are directly proportional to the stresses. The magnitude of these deformations can be computed by use of a number (ratio), called the *modulus of elasticity*, that indicates the degree of *stiffness* of a material.

A material is said to be stiff if its deformation is relatively small when the unit stress is high. As an example, a steel rod 1 in.<sup>2</sup> in cross-sectional area and 10 ft long will elongate about 0.008 in. under a tensile load of 2000 lb. But a piece of wood of the same dimensions will stretch about 0.24 in. with the same tensile load. The steel is said to be stiffer than the wood because, for the same unit stress, the deformation is not as great.

Modulus of elasticity is defined as the unit stress divided by the unit deformation. Unit deformation refers to the percent of deformation and is usually called strain. It is dimensionless since it is expressed as a ratio, as follows:

$$\text{strain} = s = \frac{e}{L}$$



in which:

$s$  = the strain, or the unit deformation

$e$  = the actual dimensional change

$L$  = the original length of the member

The modulus of elasticity for direct stress is represented by the letter  $E$ , expressed in pounds per square inch, and has the same value in compression and tension for most structural materials. Letting  $f$  represent the unit stress and  $s$  the strain, then, by definition,

$$E = \frac{f}{s}$$

From Section 10.1,  $f = P/A$ . It is obvious that, if  $L$  represents the length of the member and  $e$  the total deformation, then  $s$ , the deformation per unit of length, must equal the total deformation divided by the length, or  $s = e/L$ . Now by substituting these values in the equation determined by definition,

$$E = \frac{f}{s} = \frac{P/A}{e/L} = \frac{PL}{Ae}$$

This can also be written in the form

$$e = \frac{PL}{AE}$$

in which:

$e$  = total deformation in inches

$P$  = force in pounds

$L$  = length in inches

$A$  = cross-sectional area in square inches

$E$  = modulus of elasticity in pounds per square inch

Note that  $E$  is expressed in the same units as  $f$  (pounds per square inch [kilopascals]) because, in the equation  $E = f/s$ ,  $s$  is a dimensionless number. For steel,  $E = 29,000,000$  psi [200,000,000 kPa], and for wood, depending on the species and grade, it varies from something less than 1,000,000 psi [6,895,000 kPa] to about 1,900,000 psi [13,100,000 kPa].

For concrete,  $E$  ranges from about 2,000,000 psi [13,790,000 kPa] to about 5,000,000 psi [34,475,000 kPa] for common structural grades.

**Example 4.** A 2-in. [50.8-mm] diameter round steel rod 10 ft [3.05 m] long is subjected to a tensile force of 60 kips [266,88 kN]. How much will it elongate under the load?

*Solution:* The area of the 2-in. rod is 3.1416 in.<sup>2</sup> [2027 mm<sup>2</sup>]. Checking to determine whether the stress in the bar is within the elastic limit, we find that

$$f = \frac{P}{A} = \frac{60}{3.1416} = 19.1 \text{ ksi [131,663 kPa]}$$

which is within the elastic limit of ordinary structural steel (36 ksi), so the formula for finding the deformation is applicable. From data,  $P = 60$  kips,  $L = 120$  (length in inches),  $A = 3.1416$ , and  $E = 29,000,000$ . Substituting these values, we calculate the total lengthening of the rod as

$$e = \frac{PL}{AE} = \frac{60,000 \times 120}{3.1416 \times 29,000,000} = 0.079 \text{ in. [2.0 mm]}$$

**Problem 10.3.A**

What force must be applied to a steel bar, 1 in. [25.4 mm] square and 2 ft [610 mm] long, to produce an elongation of 0.016 in. [0.4064 mm]?

**Problem 10.3.B**

How much will a nominal 8 × 8 in. [actually 190.5 mm] Douglas fir post, 12 ft [3.658 m] long, shorten under an axial load of 45 kips [200 kN]?

**Problem 10.3.C**

A routine quality control test is made on a structural steel bar that is 1 in. [25.4 mm] square and 16 in. [406 mm] long. The data developed during the test show that the bar elongated 0.0111 in. [0.282 mm] when subjected to a tensile force of 20.5 kips [91.184 kN]. Compute the modulus of elasticity of the steel.

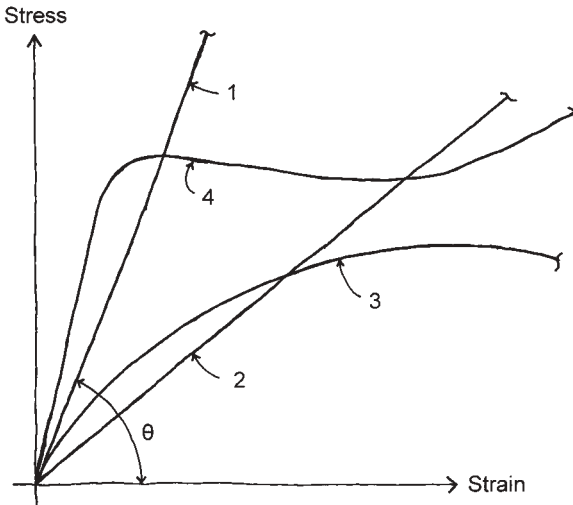
**Problem 10.3.D**

A ½ in. [12.7-mm] diameter round steel rod 40 ft [12.19 m] long supports a load of 4 kips [17.79 kN]. How much will it elongate?

### 10.4 INELASTIC AND NONLINEAR BEHAVIOR

Most of the discussion of stress and strain behavior presented so far in this book relates to the idealized theories of classic structural analysis, based on elastic and linear conditions of stress/strain interaction. While this assumption is useful for simple definitions and for derivations of fundamental relationships from which the basic equations for stress and strain computations are obtained, actual behavior of common structural materials often varies considerably from this ideal condition.

Figure 10.3 is a repeat of Figure 1.37, where it was initially used to define some fundamental terms and relationships. Linear stress/strain behavior is that represented by curves 1 and 2 in the figure. A nonlinear stress/strain relationship is demonstrated by curve 3 in the figure. While a single value for the modulus of elasticity ( $E$ ) may be obtained for the materials represented by curves 1 and 2, such is not the case for the material represented by curve 3. Metals and ceramics generally exhibit the behavior shown by curves 1 and 2, and thus a single value for  $E$  may be used for these materials throughout a considerable range of stress magnitude. Wood and concrete have responses more of the form of curve

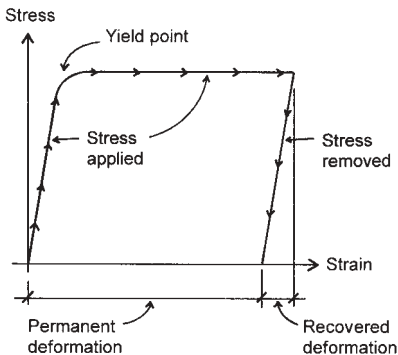


**Figure 10.3** Stress-strain relationships, through a range from zero stress to failure.

3, and thus some adjustment must be made when stress/strain involvements extend over some range of magnitude.

A second consideration concerns the relative elasticity of materials. This generally refers to how much of the strain is recoverable when the stress is removed from the material. A good rubber band, for example, can be stretched considerably and be expected to return entirely to its original length when let go. The same goes for structural materials—up to some limit. Consider curve 4 in Figure 10.3, which represents the general nature of stress/strain response of a ductile material, such as ordinary structural steel. Initially, this material displays a linear stress/strain response. However, when the yield point of the stress magnitude is reached, considerable strain occurs without an increase in stress. Up to the yield point, the strain is recoverable (material remains elastic), but deformations beyond this limit will produce some permanent change. This phenomenon is illustrated in Figure 10.4, in which the portion of the line with downward-pointing arrows indicates what the stress/strain response will be when the stress magnitude is reduced to zero after strain beyond the yield point occurs.

These issues relate to the general behavior of real structural materials. They become increasingly of concern when behaviors are projected to the ultimate response limits of materials. It is possible that they may be of less concern for behaviors within the general usage limits, that is, up to the maximum anticipated service conditions for a structure. Therefore, they are not so much a concern for the expected actual use of the struc-



**Figure 10.4** Stress-strain behavior for a ductile material.

ture. However, they may—and indeed do—relate quite significantly to the character of responses at the ultimate capacity of the structure in terms of material behavior.

The work in this book, being of an introductory nature, deals primarily with simple, idealized material responses. This is both a logical starting point and a necessary reference point for more complex investigations. Most current structural design work uses methods that are based on evaluation of ultimate load conditions, called *strength behavior* or *strength design*. The use of the term strength here refers to *ultimate strength* of the materials or of the whole structure. It is not possible here to fully present the background for these methods, which are unavoidably based considerably on inelastic and nonlinear behaviors. However, some discussion of nonlinear behavior of steel is provided in Section 11.10 and the ultimate stress limit for concrete is discussed in Chapter 15.

# 11

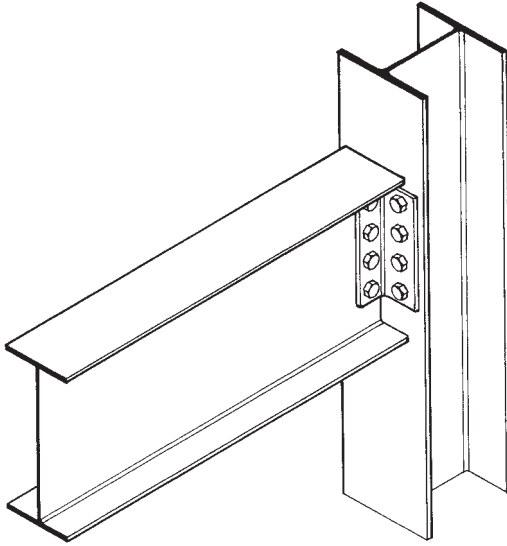
---

## STRESS AND STRAIN IN BEAMS

---

The behavior of beams with regard to their resolution of the external forces of the loads and support reactions is discussed in Chapter 4. Also discussed in Chapter 4 is the development of the internal force effects of shear and bending moment as generated by the external forces. In this chapter, the discussion relates to how the beam produces the necessary internal resistance to shear and bending through stresses in the material of the beam. Since stress is unavoidably accompanied by strain, it is also necessary to consider the deformation of the beam; the major effect consists of deflection, manifested as a curving of the beam away from its form prior to loading.

Primary considerations for beam stresses and strains have influenced the development of widely used structural products, such as the I-shaped steel shapes shown in Figure 11.1. For the I-shaped beam, the vertical web is ideally oriented for resistance to vertical shear forces, and the widely separated flanges are ideally oriented for opposed tension/compression forces to resist bending moment.



**Figure 11.1** The standard cross section of steel I-shaped beams has been established with consideration of the properties of the material, the basic production process of hot rolling, and the means of attachment of steel members in building frameworks. However, the primary consideration is the usage of the member as a beam, with its web oriented in the plane of vertical gravity force. The form and specific dimensions of each of the several hundred standard shapes thus responds essentially to the stress and strain functions for beam action. Reproduced from *Fundamentals of Building Construction*, 2nd edition, by E. Allen, 1990, with permission of the publisher, John Wiley & Sons, New York.

## 11.1 DEVELOPMENT OF BENDING RESISTANCE

As developed in the preceding sections, bending moment is a measure of the tendency of the external forces on a beam to deform it by bending. The purpose of this section is to consider the action within the beam that resists bending, called the *resisting moment*.

Figure 11.2*a* shows a simple beam, rectangular in cross section, supporting a single concentrated load  $P$ . Figure 11.2*b* is an enlarged sketch of the left-hand portion of the beam between the reaction and section X-X. It is observed that the reaction  $R_1$  tends to cause a clockwise rotation about point  $A$  in the section under consideration; this is defined as the

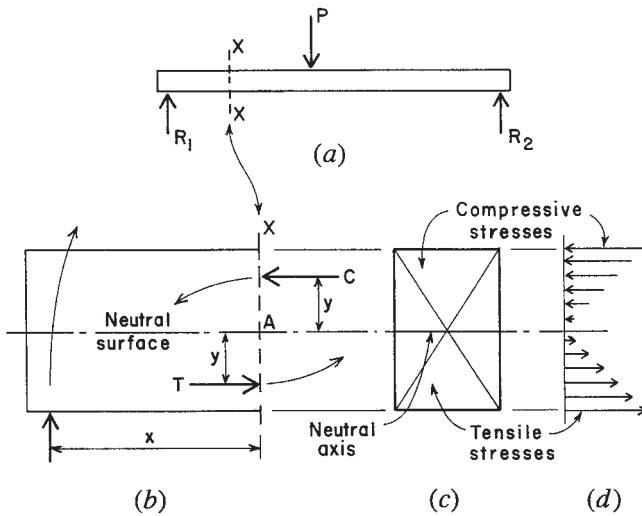


Figure 11.2 Development of bending stress in a beam.

bending moment in the section. In this type of beam, the fibers in the upper part are in compression, and those in the lower part are in tension. There is a horizontal plane separating the compressive and tensile stresses; it is called the *neutral surface*, and at this plane there are neither compressive nor tensile stresses with respect to bending. The line in which the neutral surface intersects the beam cross section (Figure 11.2c) is called the *neutral axis*, NA.

Call  $C$  the sum of all the compressive stresses acting on the upper part of the cross section, and call  $T$  the sum of all the tensile stresses acting on the lower part. It is the sum of the moments of those stresses at the section that holds the beam in equilibrium; this is called the *resisting moment* and is equal to the bending moment in magnitude. The bending moment about  $A$  is  $R_1 \times x$ , and the resisting moment about the same point is  $(C \times y) + (T \times y)$ . The bending moment tends to cause a clockwise rotation, and the resisting moment tends to cause a counterclockwise rotation. If the beam is in equilibrium, these moments are equal, or

$$R_1 \times x = (C \times y) + (T \times y)$$

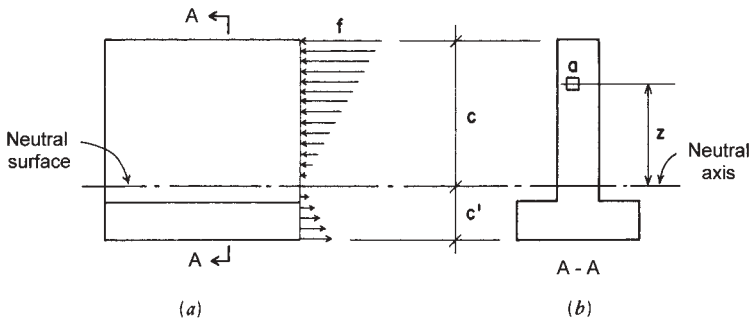


that is, the bending moment equals the resisting moment. This is the theory of flexure (bending) in beams. For any type of beam, it is possible to compute the bending moment, and to design a beam to withstand this tendency to bend; this requires the selection of a member with a cross section of such shape, area, and material that it is capable of developing a resisting moment equal to the bending moment.

### The Flexure Formula

The flexure formula,  $M = fS$ , is an expression for resisting moment (represented by  $M$ ) that involves the size and shape of the beam cross section (represented by  $S$  in the formula) and the material of which the beam is made (represented by  $f$ ). It is used in the design of all homogeneous beams, that is, beams made of one material only, such as steel or wood. The following brief derivation is presented to show the principles on which the formula is based.

Figure 11.3 represents a partial side elevation and the cross section of a homogeneous beam subjected to bending stresses. The cross section shown is unsymmetrical about the neutral axis, but this discussion applies to a cross section of any shape. In Figure 11.3a, let  $c$  be the distance of the fiber farthest from the neutral axis, and let  $f$  be the unit stress on the fiber at distance  $c$ . If  $f$ , the extreme fiber stress, does not exceed the elastic limit of the material, the stresses in the other fibers are directly proportional to their distances from the neutral axis. That is to say, if one fiber is twice as far from the neutral axis as another fiber, the fiber at the greater distance will have twice the stress. The stresses are indicated in



**Figure 11.3** Distribution of bending stress on a beam cross section.

the figure by the small lines with arrows, which represent the compressive and tensile stresses acting toward and away from the section, respectively. If  $c$  is in inches, the unit stress on a fiber at 1-in. distance is  $f/c$ . Now imagine an infinitely small area  $a$  at  $z$  distance from the neutral axis. The unit stress on this fiber is  $(f/c) \times z$ , and because this small area contains  $a$  square inches, the total stress on fiber  $a$  is  $(f/c) \times z \times a$ . The moment of the stress on fiber  $a$  at  $z$  distance is

$$\frac{f}{c} \times z \times a \times z \quad \text{or} \quad \frac{f}{c} \times a \times z^2$$

There is an extremely large number of these minute areas. Using the symbol  $\Sigma$  to represent the sum of this very large number,

$$\Sigma \left( \frac{f}{c} \times a \times z^2 \right)$$

means the sum of the moments of all the stresses in the cross section with respect to the neutral axis. This is the *resisting moment*, and it is equal to the bending moment.

Therefore

$$M_R = \frac{f}{c} \times \Sigma(a \times z^2)$$

The quantity  $\Sigma(a \times z^2)$  may be read "the sum of the products of all the elementary areas times the square of their distances from the neutral axis." This is called the *moment of inertia* and is represented by the letter  $I$  (see Section 9.2). Therefore, substituting in the above,

$$M_R = \frac{f}{c} \times I \quad \text{or} \quad M_R = \frac{fI}{c}$$

This is known as the *flexure formula* or *beam formula*, and, by its use, it is possible to design any beam that is composed of a single material. The expression may be simplified further by substituting  $S$  for  $I/c$ , called the *section modulus*, a term that is described more fully in Section 9.4. Making this substitution, the formula becomes

$$M = fS$$

### 11.2 INVESTIGATION OF BEAMS

One use of the flexure formula is for the investigation of beams. A primary investigation is that performed to determine whether a beam is strong enough for a certain loading. In regard to bending, the flexure formula may be used to determine the maximum bending stress caused by the loading. This stress is then compared to the maximum permitted for the material of the beam.

Another method for achieving the same investigation is to determine the section modulus required based on the loading and the limiting bending stress. This value for  $S$  is then compared to that for the given beam.

Finally, a third method for achieving this investigation is to compute the maximum bending moment produced by the loading and then compare it to the maximum resisting moment for the beam as determined by its section modulus and the limiting bending stress.

These three methods for investigating the same problem simply use three variations of the form of the basic flexure formula. The following example demonstrates these methods.

**Example 1.** A W 10 × 33 steel beam is proposed to carry a total uniformly distributed load of 30 kips on a span of 13 ft (see Figure 11.4). The maximum allowable bending stress is 24 ksi. Determine whether the beam is safe by (a) finding the maximum bending stress caused by the loading, (b) comparing the required section modulus to that of the given beam, (c) comparing the maximum bending moment due to the loading to the maximum resisting moment of the beam.

*Solution:* From Case 2 in Figure 4.20, the equation for maximum bending moment for the loading is found and computed as

$$M = \frac{WL}{8} = \frac{30 \times 13}{8} = 48.8 \text{ kip-ft} \quad \text{or} \quad 48.8 \times 12 = 585.6 \text{ kip-in.}$$

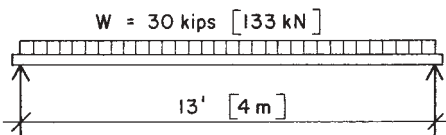


Figure 11.4 Example 1.

From Table 9.3, the section modulus for the beam is 36.6 in.<sup>3</sup>. Then

- (a) The maximum bending stress due to the maximum moment is

$$f = \frac{M}{S} = \frac{585.6}{36.6} = 16.0 \text{ ksi}$$

As this is less than the allowable stress, the beam is safe.

- (b) The section modulus required for the maximum moment of 585.6 kip-ft, with the allowable stress of 24 ksi, is

$$S = \frac{M}{f} = \frac{585.6}{24} = 24.4 \text{ in.}^3$$

As this is less than that of the beam, the beam is safe.

- (c) With the beam's given section modulus and the limiting stress, the maximum resisting moment for the beam is

$$M_R = fS = 24 \times 36.6 = 878.4 \text{ kip-in.}$$

As this is greater than the required maximum moment, the beam is safe.

Obviously, it is not necessary to perform all three of these computations, as they all use the same basic equation and produce the same answer. We use all three here to gain familiarity with the use of the flexure formula for different situations.

### **Problem 11.2.A**

A W 12 × 30 has a span of 10 ft with a uniformly distributed load of 36 kips. The allowable bending stress is 24 ksi. Is the beam safe with respect to bending stress?

### **Problem 11.2.B**

A W 16 × 45 has a loading consisting of 10 kips at each of the quarter points of a 24-ft span (Figure 4.20, Case 5) and a uniformly distributed load of 5.2 kips. The allowable bending stress is 24 ksi. Is the beam safe with regard to bending stress?

### 11.3 COMPUTATION OF SAFE LOADS

The flexure formula can also be used to determine the allowable load that a given beam may carry. In this case, the given data include the beam span, the beam section modulus, and the allowable bending stress. This basic problem is used to establish data for tabulation of safe loads for beams for various spans. The following examples demonstrate the process.

**Example 2.** A W 12 × 30 has a span of 14 ft. Find the maximum concentrated load it will support at midspan if the allowable bending stress is 22 ksi.

*Solution:* From Table 9.3, the section modulus for the beam is 38.6 in.<sup>3</sup>. The maximum resisting moment for the beam is thus

$$M_R = fS = 22,000 \times 38.6 = 849,200 \text{ in.-lb,}$$

$$\text{or } \frac{849,200}{12} = 70,767 \text{ ft-lb}$$

This is the maximum resisting moment, but part of it will be used up by the beam in supporting its own weight. As a uniformly distributed load, the 30 lb/ft on the 14-ft span will produce a moment of

$$M = \frac{wL^2}{8} = \frac{30 \times 14^2}{8} = 735 \text{ ft-lb}$$

The resisting moment available for carrying the applied load is thus

$$M = 70,767 - 735 = 70,032 \text{ ft-lb}$$

From Case 1 of Figure 4.20, the maximum moment for the concentrated loading is  $PL/4$ . To solve for  $P$ , find

$$M = \frac{PL}{4}, \quad P = \frac{4M}{L} = \frac{4 \times 70,032}{14} = 20,009 \text{ lb}$$

**Example 3.** A W 12 × 40 is used as a simple beam on a span of 14 ft. What is the maximum uniformly distributed load that this beam will carry if the allowable stress is 24 ksi?

*Solution:* From Table 9.3, the section modulus for this beam is 51.9 in.<sup>3</sup>. For this loading, from Case 2 of Figure 4.20, the maximum moment is  $WL/8$ . Then

$$M = \frac{WL}{8} = \frac{W \times 14 \times 12}{8} = 21W \text{ kip-in.}$$

The maximum resisting moment for the beam is

$$M_R = fS = 24 \times 51.9 = 1245.6 \text{ kip-in.}$$

Equating these two moments

$$21W = 1245.6, \quad W = \frac{1245.6}{21} = 59.3 \text{ kips}$$

The beam weighs a total of  $14 \times 40 = 560$  lb or approximately 0.6 kips. Deducting this, the total load the beam can support is  $59.3 - 0.6 = 58.7$  kips.

For the steel beams in the following problems, ignore the beam weight and use an allowable bending stress of 24 ksi.

***Problem 11.3.A***

Compute the maximum allowable uniformly distributed load for a simple beam with a span of 16 ft if the section used is a W 12 × 30.

***Problem 11.3.B***

An 8 × 12 wood beam, for which the allowable bending stress is 1400 psi, has a span of 15 ft with equal concentrated loads at the third points of the span (Case 3 in Figure 4.20). Compute the maximum permitted value for the individual load.

***Problem 11.3.C***

A W 14 × 30 having a span of 14 ft supports a uniformly distributed load of 7 kips and also a concentrated load at the center of the span. Compute the maximum allowable value for the concentrated load.

***Problem 11.3.D***

What is the maximum concentrated load that may be placed at the free end of a cantilever beam 9 ft long if the section used is a W 12 × 26?

**Problem 11.3.E**

A simple beam has a span of 20 ft with a concentrated load placed 4 ft from one of the supports. If the section is a W 16 × 36, compute the allowable value for the concentrated load.

**11.4 DESIGN OF BEAMS FOR FLEXURE**

The flexure formula is used primarily to determine the size of a beam with respect to strength in bending. Shear and deflection must also be considered, but it is common to first pick a size required for bending and then to investigate its adequacy for shear and deflection. The flexure formula may be used directly for this task—as demonstrated in the following examples—but the frequency of occurrence of the problem encourages the use of various aids to shorten the process. Professional designers will commonly avail themselves of these aids.

**Example 4.** A simple beam spans 22 ft and supports a uniformly distributed load of 36 kips, including the beam weight. If allowable bending stress is 24 ksi, design a steel beam for strength in bending.

*Solution:* From Figure 4.20, Case 2,

$$M = \frac{WL}{8} = \frac{36 \times 22}{8} = 99 \text{ kip-ft}, \quad \text{or } 99 \times 12 = 1188 \text{ kip-in.}$$

Using the flexure formula, the required section modulus is found as

$$S = \frac{M}{f} = \frac{1188}{24} = 49.5 \text{ in.}^3$$

From Table 9.3, a W 16 × 36 has an  $S$  of 56.5 in.<sup>3</sup> and is therefore acceptable. Other sections having a section modulus of at least 49.5 in.<sup>3</sup> are also acceptable. If there is no other criteria, the lightest-weight section is usually the most economical. (The last number in the designation for the W-shape indicates its weight in pounds per foot of length.)

**Example 5.** A simple beam of wood has a span of 16 ft and supports a uniformly distributed load of 6500 lb including its own weight. If the

wood is to be Douglas fir, Select Structural grade, with allowable bending stress of 1600 psi, determine the required size of the beam with the least cross-sectional area on the basis of limiting bending stress.

*Solution:* The maximum bending moment is

$$M = \frac{WL}{8} = \frac{6500 \times 16}{8} = 13,000 \text{ lb-ft,} \quad \text{or } 156,000 \text{ lb-in.}$$

The allowable bending stress is 1600 psi. Then the required section modulus is determined as

$$S = \frac{M}{f} = \frac{156,000}{1600} = 97.5 \text{ in.}^3$$

From Table 9.7, the wood timber section with the least area to satisfy this requirement is a 6 × 14 with  $S = 167 \text{ in.}^3$ .

Ignore the beam weight in the following problems. Use allowable bending stresses of 24 ksi for steel and 1600 psi for wood.

***Problem 11.4.A***

A simple beam has a span of 17 ft and supports a uniformly distributed load of 23 kips. Determine the size required for a steel W-shape with the least weight to carry this load.

***Problem 11.4.B***

Two loads of 11 kips each occur at the third points of the span of a simple beam with a span of 18 ft. Find the least-weight W-shape that is acceptable.

***Problem 11.4.C***

A simple beam with a 20-ft span has a concentrated load of 20 kips at its center and also a uniformly distributed load of 200 lb/ft over its entire length. Find the least-weight W-shape that is acceptable.

***Problem 11.4.D***

A wood beam of Douglas fir, Select Structural grade, has a span of 15 ft and carries a concentrated load of 9.6 kips at 5 ft from one end. Find the least-weight (least cross-sectional area) member that is acceptable.



## 11.5 SHEAR STRESS IN BEAMS

Shear is developed in beams in direct resistance to the vertical force at a beam cross section. Because of the interaction of shear and bending in the beam, the exact nature of stress resistance within the beam depends on the form and materials of the beam. For an example, in wood beams, the wood grain is normally oriented in the direction of the span and the wood material has a very low resistance to horizontal splitting along the grain. An analogy to this is represented in Figure 11.5, which shows a stack of loose boards subjected to a beam loading. With nothing but minor friction between the boards, the individual boards will slide over each other to produce the loaded form indicated in the bottom figure. This is the failure tendency in the wood beam, and the shear phenomenon for wood beams is usually described as one of *horizontal shear*.

Shear stresses in beams are not distributed evenly over the cross section of the beam, as was assumed for the case of simple direct shear (see Section 2.3). From observations of tested beams and derivations considering the equilibrium of beam segments under combined actions of shear and bending, the following expression has been obtained for shear stress in a beam.

$$f_v = \frac{VQ}{Ib}$$

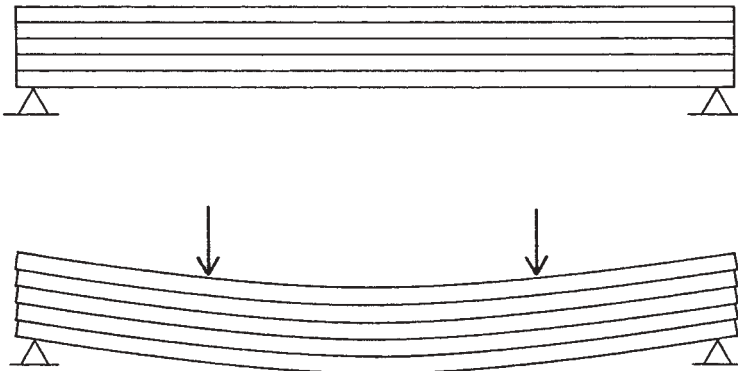


Figure 11.5 Nature of horizontal shear in beams.

in which:

$V$  = shear force at the beam section

$Q$  = moment about the neutral axis of the portion of the cross-sectional area between the edge of the section and the point where stress is being computed

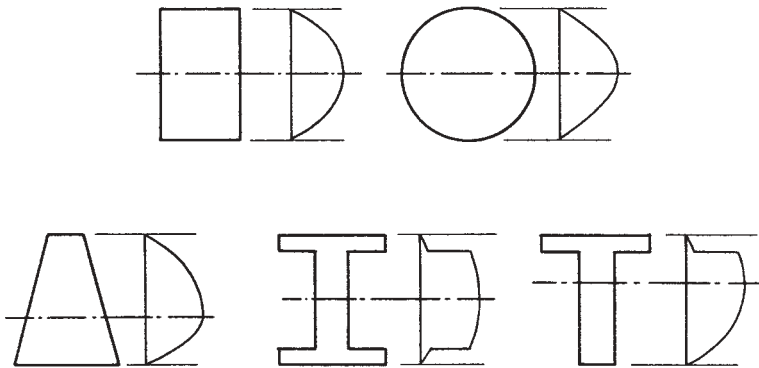
$I$  = moment of inertia of the section with respect to the neutral (centroidal) axis

$b$  = width of the section at the point where stress is being computed

It may be observed that the highest value for  $Q$ , and thus for shear stress, will occur at the neutral axis and that shear stress will be zero at the top and bottom edges of the section. This is essentially opposite to the form of distribution of bending stress on a section. The form of shear distribution for various geometric shapes of beam sections is shown in Figure 11.6.

The following examples illustrate the use of the general shear stress formula.

**Example 6.** A rectangular beam section with depth of 8 in. and width of 4 in. sustains a shear force of 4 kips. Find the maximum shear stress (see Figure 11.7a).



**Figure 11.6** Distribution of shear stress in beams with various cross sections.

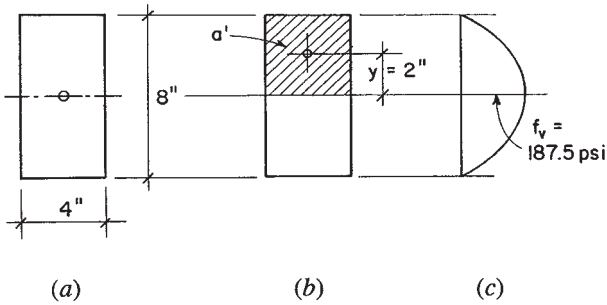


Figure 11.7 Example 6.

*Solution:* For the rectangular section, the moment of inertia about the centroidal axis is (see Figure 9.12).

$$I = \frac{bd^3}{12} = \frac{4 \times 8^3}{12} = 170.7 \text{ in.}^4$$

The static moment ( $Q$ ) is the product of the area  $a'$  and its centroidal distance from the neutral axis ( $y$  as shown in Figure 11.7*b*). This is the greatest value that can be obtained for  $Q$  and will produce the highest shear stress for the section. Thus,

$$Q = a'y = (4 \times 4)(2) = 32 \text{ in.}^3$$

and

$$f_v = \frac{VQ}{Ib} = \frac{4000 \times 32}{170.7 \times 4} = 187.5 \text{ psi}$$

**Example 7.** A beam with the T-section shown in Figure 11.8*a* is subjected to a shear force of 8 kips. Find the maximum shear stress and the value of shear stress at the location of the juncture of the web and the flange of the T.

*Solution:* Since this section is not symmetrical with respect to its horizontal centroidal axis, the first steps for this problem consist of locating the neutral axis and determining the moment of inertia for the section with respect to the neutral axis. To save space, this work is not shown here, although it is performed as Examples 1 and 8 in Chapter 9. From

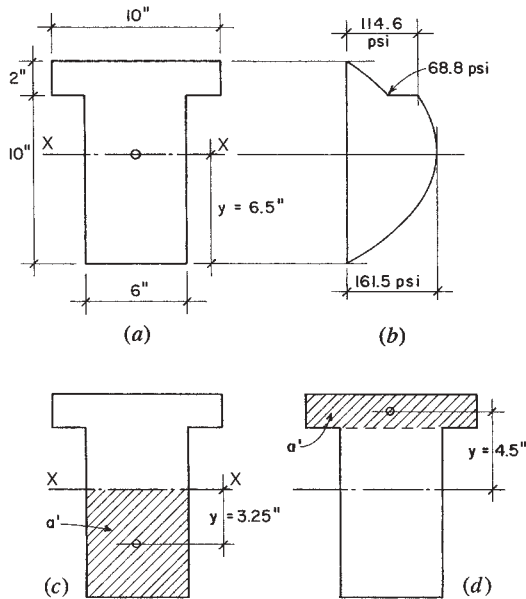


Figure 11.8 Example 7.

that work, it is found that the centroidal neutral axis is located at 6.5 in. from the bottom of the T and the moment of inertia about the neutral axis is 1046.7 in.<sup>4</sup>.

For computation of the maximum shear stress at the neutral axis, the value of  $Q$  is found by using the portion of the web below the neutral axis, as shown in Figure 11.8c. Thus,

$$Q = a'y = (6.5 \times 6) \times \left(\frac{6.5}{2}\right) = 126.75 \text{ in.}^3$$

and the maximum stress at the neutral axis is thus

$$f_v = \frac{VQ}{Ib} = \frac{8000 \times 126.75}{1046.7 \times 6} = 161.5 \text{ psi}$$

For the stress at the juncture of the web and flange,  $Q$  is determined using the area shown in Figure 11.8d. Thus,

$$Q = (2 \times 10)(4.5) = 90 \text{ in.}^3$$

And the two values for shear stress at this location, as displayed in Figure 11.8b, are

$$f_v = \frac{8000 \times 90}{1046.7 \times 6} = 114.6 \text{ psi (in the web)}$$

$$f_v = \frac{8000 \times 90}{1046.7 \times 10} = 68.8 \text{ psi (in the flange)}$$

In many situations, it is not necessary to use the complex form of the general expression for shear stress in a beam. For wood beams, the sections are mostly simple rectangles, for which the following simplification can be made.

For the simple rectangle, from Figure 9.12,  $I = bd^3/12$ . Also,

$$Q = \left[ b \times \left( \frac{d}{2} \right) \right] \left( \frac{d}{4} \right) = \frac{bd^2}{8}$$

Thus

$$f_v = \frac{VQ}{Ib} = \frac{V \times (bd^2/8)}{(bd^3/12) \times b} = 1.5 \left( \frac{V}{bd} \right)$$

This is the formula specified by design codes for investigation of shear in wood beams.

### **Problem 11.5.A**

A beam has an I-shaped cross section with an overall depth of 16 in. [400 mm], web thickness of 2 in. [50 mm], and flanges that are 8 in. wide [200 mm] and 3 in. [75 mm] thick. Compute the critical shear stresses and plot the distribution of shear stress on the cross section if the beam sustains a shear force of 20 kips [89 kN].

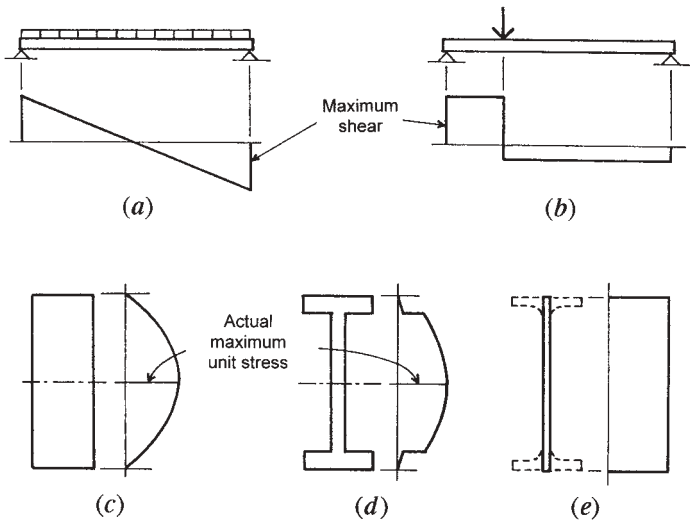
### **Problem 11.5.B**

A T-shaped beam cross section has an overall depth of 18 in. [450 mm], web thickness of 4 in. [100 mm], flange width of 8 in. [200 mm], and flange thickness of 3 in. [75 mm]. Compute the critical shear stresses and plot the distribution of shear stress on the cross section if the beam sustains a shear force of 12 kips [53.4 kN].

### 11.6 SHEAR IN STEEL BEAMS

Shear in beams consists of the vertical slicing effect produced by the opposition of the vertical loads on the beams (downward) and the reactive forces at the beam supports (upward). The internal shear force mechanism is visualized in the form of the shear diagram for the beam. With a uniformly distributed load on a simply supported beam, this diagram takes the form shown in Figure 11.9*a*.

As the shear diagram for the uniformly loaded beam shows, this load condition results in an internal shear force that peaks to a maximum value at the beam supports and steadily decreases in magnitude to zero at the center of the beam span. With a beam having a constant cross section throughout the span, the critical location for shear is thus at the supports, and—if conditions there are adequate—there is no concern for shear at other locations along the beam. Since this is the common condition of loading for many beams, it is therefore necessary only to investigate the support conditions for such beams.



**Figure 11.9** Development of shear in beams. (a) Shear force in a uniformly loaded beam. (b) Shear force in a beam with a large concentrated load. (c) Rectangular section. (d) I-shaped section. (e) Assumed stress in W-shape.

Figure 11.9*b* shows another loading condition, that of a major concentrated load within the beam span. Framing arrangements for roof and floor systems frequently employ beams that carry the end reactions of other beams, so this is also a common condition. In this case, a major internal shear force is generated over some length of the beam. If the concentrated load is close to one support, a critical internal shear force is created in the shorter portion of the beam length between the load and the closer support.

For a simple rectangular cross section, such as that of a wood beam, the distribution of beam shear stress is as shown in Figure 11.9*c*, taking the form of a parabola with a maximum shear stress value at the beam neutral axis and a decrease to zero stress at the extreme fiber distances (top and bottom edges).

For the I-shaped cross section of the typical W-shape rolled steel beam, the beam shear stress distribution takes the form shown in Figure 11.9*d* (referred to as the “derby hat” form). Again, the shear stress is a maximum at the beam neutral axis, but the falloff is less rapid between the neutral axis and the inside of the beam flanges. Although the flanges indeed take some shear force, the sudden increase in beam width results in an abrupt drop in the beam unit shear stress. A traditional shear stress investigation for the W-shape, therefore, is based on ignoring the flanges and assuming the shear-resisting portion of the beam to be an equivalent vertical plate (Figure 11.9*e*) with a width equal to the beam web thickness and a height equal to the full beam depth. An allowable value is established for a unit shear stress on this basis, and the computation is performed as

$$f_v = \frac{V}{t_w d_b}$$

in which:

$f_v$  = the average unit shear stress, based on an assumed distribution as shown in Figure 11.9*e*

$V$  = the value for the internal shear force at the cross section

$t_w$  = the beam web thickness

$d_b$  = the overall beam depth

For ordinary situations, the allowable shear stress for W-shapes is  $0.40F_y$ , where  $F_y$  is the elastic yield value. This is rounded off to 14.5 ksi for A36 steel.

**Example 8.** A simple beam of A36 steel is 6 ft [1.83 m] long and has a concentrated load of 36 kips [160 kN] applied 1 ft [0.3 m] from one end. It is found that a W 10 × 33 is adequate for the bending moment. Investigate the beam for shear.

**Solution:** The two reactions for this loading are 30 kips [133 kN] and 6 kips [27 kN]. The maximum shear in the beam is equal to the larger reaction force.

From Table 9.3, for the given shape,  $d = 9.73$  in. and  $t_w = 0.435$  in. Then,

$$f_v = \frac{V}{t_w d_b} = \frac{30}{0.435 \times 9.73} = 7.09 \text{ ksi}$$

As this is less than the allowable value of 14.5 ksi, the shape is acceptable.

### Problems 11.6.A–C

Compute the maximum permissible shears for the following beams of A36 steel:

- (A) W 24 × 84; (B) W 12 × 40; (C) W 10 × 19.

## 11.7 FLITCHED BEAMS

The discussion of bending stresses presented thus far in this chapter pertains to beams consisting of a single material; that is, to *homogeneous* beams. Reinforced concrete construction utilizes beams of two materials—steel and concrete—acting together (Chapter 15). Another example of this condition of mixed materials is a *flitched beam*, in which steel and wood elements are fastened together so as to act as a single unit. Two means of achieving such a built-up beam section are shown in Figure 11.10. The stress behavior in a two-material beam will be illustrated by investigating the flitched beam.

A basic premise for an elastic stress/strain investigation is that the two materials deform equally when the beam is bent. Then let

$s_1$  and  $s_2$  = the deformations per unit length (strain) of the outermost fibers of the two materials, respectively

$f_1$  and  $f_2$  = the unit bending stresses in the outermost fibers of the two materials, respectively

$E_1$  and  $E_2$  = the modulus of elasticity of the two materials, respectively



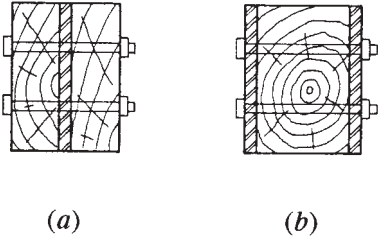


Figure 11.10 Forms of flitched beams.

Since by definition the modulus of elasticity of a material is equal to the unit stress divided by the unit deformation (strain), then

$$E_1 = \frac{f_1}{s_1} \quad \text{and} \quad E_2 = \frac{f_2}{s_2}$$

and, transposing for an expression of the unit deformations,

$$s_1 = \frac{f_1}{E_1} \quad \text{and} \quad s_2 = \frac{f_2}{E_2}$$

Since the two deformations must be equal,

$$s_1 = s_2 \quad \text{or} \quad \frac{f_1}{E_1} = \frac{f_2}{E_2}$$

from which a basic expression for the relation between the two stresses is

$$f_1 = f_2 \times \left( \frac{E_1}{E_2} \right)$$

This basic relationship may be used for the investigation or design of the two-material beam, as demonstrated in the following example.

**Example 9.** A flitched beam is formed as shown in Figure 11.10a, consisting of two 2 × 12 planks of Douglas fir, Select Structural grade, and a 0.5 × 11.25 steel plate. Compute the allowable uniformly distributed load this beam will carry on a span of 14 ft.

*Solution:* From other sources, the following data are obtained for the two materials:

For the steel,  $E = 29,000,000$  psi and the maximum allowable bending stress is 22 ksi.

For the wood,  $E = 1,900,000$  psi and the maximum allowable bending stress is 1500 psi.

For a trial, assume the stress in the steel to be the limiting condition. Then find the stress in the wood that corresponds to this limit in the steel.

$$f_w = f_s \times \left( \frac{E_w}{E_s} \right) = (22,000) \times \left( \frac{1,900,000}{29,000,000} \right) = 1441 \text{ psi}$$

As this produces a stress lower than that of the limit for the wood, the assumption is correct. That is, if a stress of 1500 psi is permitted in the wood, the stress in the steel will exceed 22,000 psi.

Now find the load that can be carried individually by each unit of the beam, using the limiting stresses just established. A procedure for this is as follows.

For the wood, the maximum bending resistance is 1441 psi and the combined section modulus for the two members is  $2 \times 31.6 = 63.2 \text{ in.}^3$  ( $S$  for the  $2 \times 12$  from Table 9.7). Then the limiting moment for the wood is

$$M_w = f_w \times S_w = 1441 \times 63.2 = 91,071 \text{ in.-lb} \quad \text{or} \quad 7,589 \text{ ft-lb}$$

For the plate, the value of  $S$  must be computed. From Figure 9.12, the section modulus for the rectangle is  $bd^2/6$ ; thus, for the plate, with  $b = 0.5$  in. and  $d = 11.25$  in.,

$$S_s = \frac{bd^2}{6} = \frac{0.5 \times (11.25)^2}{6} = 10.55 \text{ in.}^3$$

Then

$$M_s = f_s \times S_s = 22,000 \times 10.55 = 232,100 \text{ in.-lb} \quad \text{or} \quad 19,342 \text{ ft-lb}$$

The total capacity for the combined wood and steel section is thus

$$M = M_w + M_s = 7589 + 19,342 = 26,931 \text{ ft-lb}$$

Equating this to the maximum moment for a uniformly loaded simple beam (Figure 4.20, Case 2) and solving for  $W$ ,

$$M = 26,931 = \frac{WL}{8} = \frac{W(14)}{8}$$

$$W = \frac{8 \times 26,931}{14} = 15,389 \text{ lb}$$

This value for  $W$  includes the beam weight, which must be deducted to determine the allowable superimposed load.

Although the load-carrying capacity of the wood elements is slightly reduced in this beam, the total capacity is substantially greater than that of the wood members alone. This significant increase in strength achieved with a small increase in size is a principal reason for popularity of the flitched beam. However, often of greater interest is the substantial reduction of deflection and the virtual elimination of sag over time—a natural phenomenon in the ordinary wood beam.

For the following problems, use the same allowable stress and modulus of elasticity values for the materials as those given in the example and neglect the beam weight.

**Problem 11.7.A**

A flitched beam consists of two  $2 \times 10$  pieces of Douglas fir, Select Structural grade, and a single  $0.375 \times 9.25$  in. steel plate of A36 steel (Figure 11.10a). Find the magnitude of the total uniformly distributed load this beam will carry on a span of 18 ft.

**Problem 11.7.B**

A flitched beam consists of a single  $10 \times 14$  of Douglas fir, Select Structural grade, and two A36 steel plates, each  $0.5 \times 13.5$  in. (Figure 11.10b). Find the magnitude of the single concentrated load that this beam will carry at the center of a 16 ft span.

## 11.8 DEFLECTION OF BEAMS

Deformations of structures must often be controlled for various reasons. These reasons sometimes relate to the proper functioning of the structure itself, but more often relate to effects on the supported construction or the overall purposes of the structure.

To steel's advantage is the relative stiffness of the material itself. With a modulus of elasticity of 29,000 ksi, it is 8 to 10 times as stiff as average structural concrete and 15 to 20 times as stiff as structural lumber. However, it is usually the overall deformation of whole structural elements or assemblages that must be controlled; in this regard, steel structures are frequently quite deformable and flexible. Because of its cost, steel is usually formed into elements with thin parts (beam flanges and webs, for example), and because of its high strength, it is frequently formed into relatively slender elements (beams and columns, for example).

For a beam in a horizontal position, the critical deformation is usually the maximum sag, called the beam's *deflection*. For most beams, this deflection will be too small in magnitude to be detected by eye. However, any load on a beam, such as that in Figure 11.11, will cause some amount of deflection, beginning with the beam's own weight. In the case of the simply supported, symmetrical, single-span beam in Figure 11.11, the maximum deflection will occur at midspan; this is usually the only deformation value of concern for design. However, as the beam deflects, its ends rotate unless restrained, and this deformation may also be of concern in some situations.

If deflection is determined to be excessive, the usual remedy is to select a deeper beam. Actually, the critical property of the beam cross section is its *moment of inertia* ( $I$ ) about its major axis ( $I_x$  for a W-shape), which is typically affected significantly by increases in depth of the beam. Formulas for deflection of beams take a typical form that involves variables as follows:

$$D = C \left( \frac{WL^3}{EI} \right)$$

(Note: the Greek uppercase letter delta ( $\Delta$ ) is also used as the symbol for deflection)

in which:

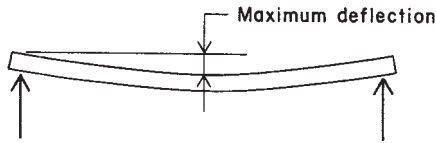
$D$  = the deflection, measured vertically in units of inches or millimeters

$C$  = a constant related to the form of the load and support conditions for the beam

$W$  = the load on the beam

$L$  = the span of the beam

$E$  = the modulus of elasticity of the material of the beam



**Figure 11.11** Deflection of a simple beam under symmetrical loading.

$I$  = the moment of inertia of the beam cross section for the axis about which bending occurs

Note that the magnitude of the deflection is directly proportional to the magnitude of the load; double the load, double the deflection. However, the deflection is proportional to the third power of the span; double the span and you get  $2^3$  or eight times the deflection. For resistance to deflection, increases in either the material's stiffness or the beams geometric form ( $I$ ) will cause direct proportional reduction of the deflection.

### Allowable Deflections

What is permissible for beam deflection is mostly a matter of judgement by experienced designers. It is difficult to provide specific limitations to avoid various deflection problems. Each situation must be investigated individually and some cooperative decisions made about the necessary design controls by the designers of the structure and those who develop the rest of the building construction.

For spanning beams in ordinary situations some rules of thumb have been derived over many years of experience. These usually consist of establishing some maximum degree of beam curvature described in the form of a limiting ratio of the deflection to the beam span  $L$ , expressed as a fraction of the span; for example,  $L/100$ . These are sometimes, although not always, specified in general design codes or legally enacted building codes. Some typical limitations recognized by designers are the following:

For a minimum limit to avoid visible sag on short to medium spans, a total load deflection of:	1/150
For total load deflection of a roof structure:	1/180
For deflection under live load only for a roof structure:	1/240
For total load deflection of a floor structure:	1/240
For deflection under live load only for a floor structure:	1/360

### Deflection of Uniformly Loaded Simple Beams

The most frequently used beam in flat roof and floor systems is the uniformly loaded beam with a single, simple span (no end restraint). This situation is shown in Figure 4.20 as Case 2. For this case, the following values may be obtained for the beam behavior:

Maximum bending moment:

$$M = \frac{WL}{8}$$

Maximum stress on the beam cross section:

$$f = \frac{Mc}{I}$$

Maximum midspan deflection:

$$D = \left( \frac{5}{384} \right) \left( \frac{WL^3}{EI} \right)$$

Using these relationships, together with the typical case of a known modulus of elasticity ( $E = 29,000$  ksi for steel) and a common limit for bending stress for W-shapes of 24 ksi, a convenient formula can be derived for deflection of steel beams. Noting that the dimension  $c$  in the bending stress formula is  $d/2$  for symmetrical shapes, and substituting the expression for  $M$ , we can say

$$f = \frac{Mc}{I} = \frac{(WL/8)(d/2)}{I} = \frac{WLd}{16I}$$

Then

$$\begin{aligned} D &= \left( \frac{5}{384} \right) \times \left( \frac{WL^3}{EI} \right) \\ &= \left( \frac{WLd}{16I} \right) \left( \frac{5L^2}{24Ed} \right) \\ &= (f) \left( \frac{5L^2}{24Ed} \right) \\ &= \frac{5fL^2}{24Ed} \end{aligned}$$

This is a basic formula for any beam symmetrical about its bending axis. For a shorter version, use values of 24 ksi for  $f$  and 29,000 ksi for  $E$ . Also, for convenience, spans are usually measured in feet, not inches, so a factor of 12 is figured in. Thus,

$$\begin{aligned} D &= \frac{5fL^2}{24Ed} \\ &= \left(\frac{5}{24}\right) \times \left(\frac{24}{29,000}\right) \times \left[\frac{(12L)^2}{d}\right] \\ &= 0.02483 L^2/d \end{aligned}$$

In metric units, with  $f = 165$  MPa,  $E = 200$  GPa, and the span in meters,

$$D = \frac{0.00017179L^2}{d}$$

## 11.9 DEFLECTION COMPUTATIONS

The following examples illustrate the investigation for deflection of the uniformly loaded simple beam.

**Example 10.** A simple beam has a span of 20 ft [6.10 m] and a total uniformly distributed load of 39 kips [173.5 kN]. The beam is a steel W 14  $\times$  34. Find the maximum deflection.

*Solution:* First, determine the maximum bending moment as

$$M = \frac{WL}{8} = \frac{39 \times 20}{8} = 97.5 \text{ kip-ft}$$

Then, from Table 9.3,  $S = 48.6 \text{ in.}^3$ , and the maximum bending stress is

$$f = \frac{M}{S} = \frac{97.5 \times 12}{48.6} = 24.07 \text{ ksi}$$

which is sufficiently close to the value of the limiting stress of 24 ksi to consider the beam stressed exactly to its limit. Thus, the derived formula may be used without modification. From Table 9.3, the true depth of the beam is 13.98 in. Then

$$D = \frac{0.2483L^2}{d} = \frac{0.02483 \times 20^2}{13.98} = 0.7104 \text{ in. [18.05 mm]}$$

For a check, the general formula for deflection of the simple beam with uniformly distributed load can be used. For this, it is found that the value of  $I$  for the beam from Table 9.3 is 340 in.<sup>4</sup>. Then

$$D = \frac{5WL^3}{384EI} = \frac{5(39)(20 \times 12)^3}{384 \times 29,000 \times 340} = 0.712 \text{ in.}$$

which is close enough for a verification.

In a more typical situation, the chosen beam is not precisely stressed at 24 ksi. The following example illustrates the procedure for this situation.

**Example 11.** A simple beam consisting of a W 12 × 26 carries a total uniformly distributed load of 24 kips [107 kN] on a span of 19 ft [5.79 m]. Find the maximum deflection.

*Solution:* As in Example 1, find the maximum bending moment and the maximum bending stress.

$$M = \frac{WL}{8} = \frac{24 \times 19}{8} = 57 \text{ kip-ft}$$

From Table 9.3,  $S$  for the beam is 33.4 in.<sup>3</sup>; thus,

$$f = \frac{M}{S} = \frac{57 \times 12}{33.4} = 20.48 \text{ ksi}$$

With the deflection formula that is based only on span and beam depth, the basis for bending stress is a value of 24 ksi. Therefore, an adjustment must be made consisting of the ratio of true bending stress to 24 ksi; thus,

$$\begin{aligned} D &= \left( \frac{20.48}{24} \right) \times \left( \frac{0.02483L^2}{d} \right) \\ &= (0.8533) \times \left[ \frac{(0.02483 \times 19^2)}{12.22} \right] \\ &= 0.626 \text{ in. [16 mm]} \end{aligned}$$



The derived deflection formula involving only span and beam depth can be used to plot a graph that displays the deflection of a beam of a constant depth for a variety of spans. Figure 11.12 consists of a series of such graphs for beams from 6 to 36 in. in depth. Use of these graphs presents yet another means for determining beam deflections. The reader may verify that deflections may be found from the graphs for the beams in Examples 1 and 2, with reasonable agreement with the computed results. An answer within about 5% should be considered reasonable from the graphs.

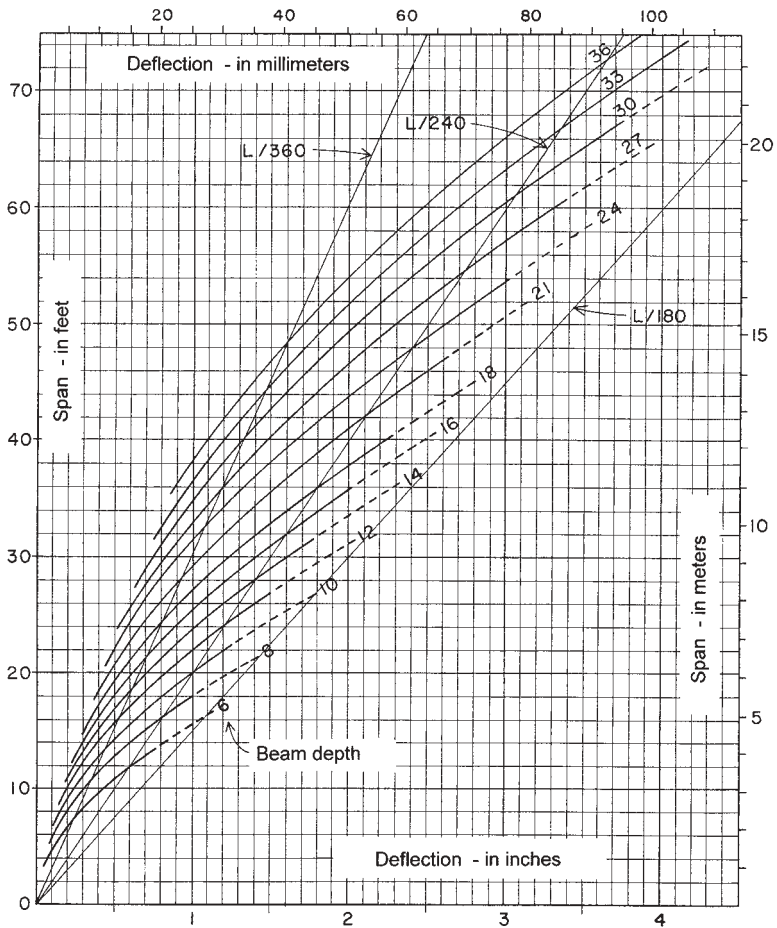
A second deflection graph is shown in Figure 11.13, in this case for wood beams. While the value of  $E$  is constant for steel, it varies over a considerable range for various species and grades of wood. The graphs in Figure 11.13 are based on an assumed value of 1,500,000 psi for the modulus of elasticity. The value of allowable bending stress also varies, with a value assumed here of 1500 psi. These values are average for the members typically used for timber beams.

The real value of the graphs in Figures 11.12 and 11.13 is in the design process. Once the necessary span is known, the designer can determine from the graphs what beam depth is required for a given deflection. The limiting deflection may be given in an actual dimension, or more commonly, as a limiting percentage of the span ( $1/240$ ,  $1/360$ , etc.), as previously discussed. To aid in the latter situation, lines are drawn on the graph representing the usual percentage limits of  $1/360$ ,  $1/240$ , and  $1/180$  (see previous discussion in this section for deflection limits). Thus, if a steel beam is to be used for a span of 36 ft, and the total load deflection limit is  $L/240$ , it may be observed in Figure 11.12 that the lines for a span of 36 ft and a ratio of  $1/240$  intersect almost precisely on the curve for an 18-in. deep beam. This means that an 18-in. deep beam will deflect almost precisely  $1/240$ th of the span if stressed in bending to 24 ksi. Thus, any beam chosen with less depth will be inadequate for deflection, and any beam greater in depth will be conservative in regard to deflection.

Determination of deflections for other than uniformly loaded simple beams is considerably more complicated. However, many handbooks provide formulas for computation of deflections for a variety of beam loading and support situations.

### ***Problems 11.9.A–C***

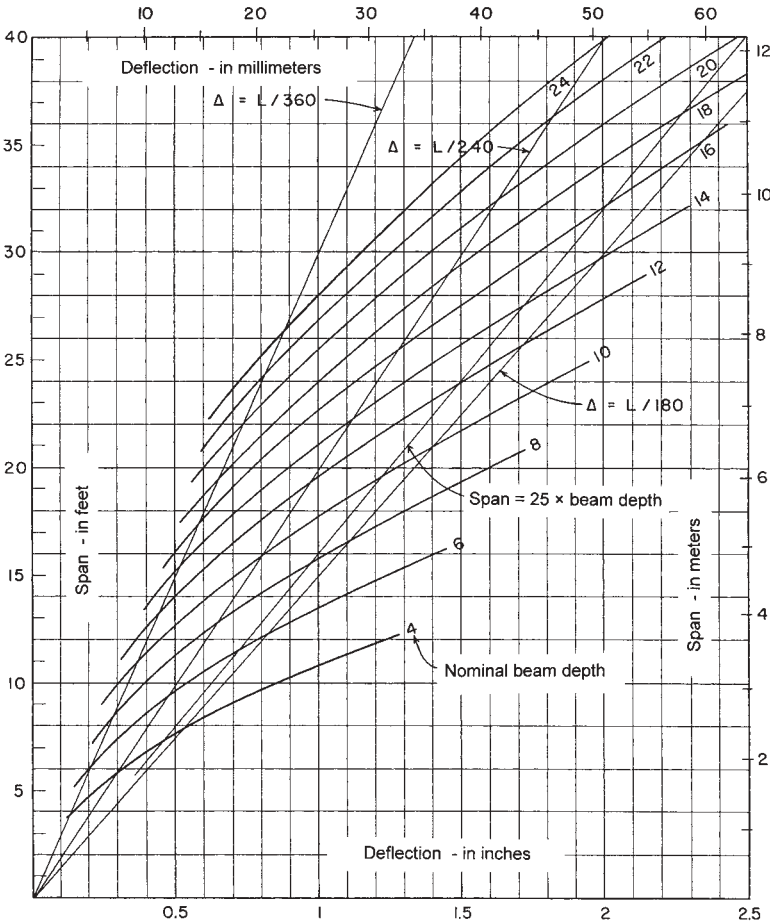
Find the maximum deflection in inches for the following simple beams of A36 steel with uniformly distributed load. Find the values using:



**Figure 11.12** Deflection of uniformly loaded, simple-span steel beams with a maximum bending stress of 24 ksi [165 Mpa].

(a) the equation for Case 2 in Figure 4.20; (b) the formula involving only span and beam depth; (c) the curves in Figure 11.12.

- (A) W 10 × 33, span = 18 ft, total load = 30 kips [5.5 m, 133 kN]
- (B) W 16 × 36, span = 20 ft, total load = 50 kips [6 m, 222 kN]
- (C) W 18 × 46, span = 24 ft, total load = 55 kips [7.3 m, 245 kN]



**Figure 11.13** Deflection of uniformly loaded, simple-span wood beams with maximum bending stress of 1500 psi [10 Mpa] and modulus of elasticity of 1,500,000 psi [10 Gpa].

**11.10 PLASTIC BEHAVIOR IN STEEL BEAMS**

The maximum resisting moment by elastic theory is predicted to occur when the stress at the extreme fiber reaches the elastic yield value  $F_y$ , and it may be expressed as

$$M_y = F_y \times S$$

Beyond this condition, the resisting moment can no longer be expressed by elastic theory equations since an inelastic, or *plastic*, stress condition will start to develop on the beam cross section.

Figure 11.14 represents an idealized form of a load-test response for a specimen of ductile steel. The graph shows that, up to the yield point, the deformations are proportional to the applied stress and that, beyond the yield point, there is a deformation without an increase in stress. For A36 steel, this additional deformation, called the *plastic range*, is approximately 15 times that produced just before yield occurs. This relative magnitude of the plastic range is the basis for qualification of the material as significantly ductile.

Note that beyond the plastic range the material once again stiffens, called the *strain-hardening* effect, which indicates a loss of the ductility and the onset of a second range in which additional deformation is produced only by additional increase in stress. The end of this range establishes the *ultimate stress* limit for the material.

For plastic failure to be significant, the extent of the plastic range of deformation must be several times that of the elastic range, as it is indeed for A36 steel. As the yield limit of steel is increased in higher grades, the

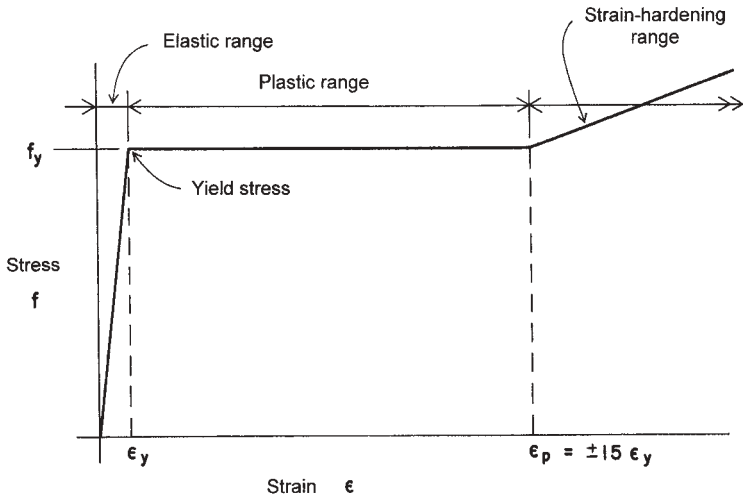


Figure 11.14 Idealized form of the stress-strain behavior of ductile steel.

plastic range decreases, so that the plastic theory of behavior is at present generally limited in application to steels with a yield point not exceeding 65 ksi [450 MPa].

The following example illustrates the application of the elastic theory and will be used for comparison with an analysis of plastic behavior.

**Example 12.** A simple beam has a span of 16 ft [4.88 m] and supports a single concentrated load of 18 kips [80 kN] at its center. If the beam is a W 12 × 30, compute the maximum flexural stress.

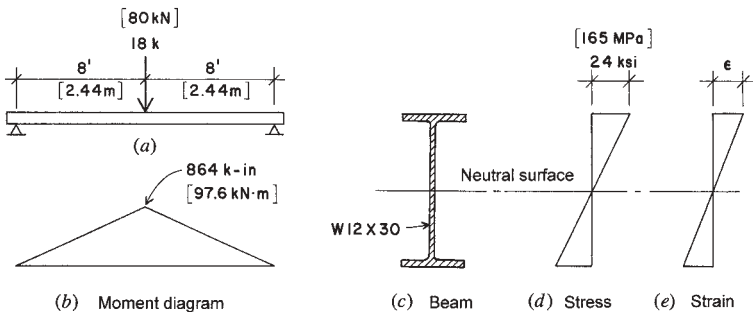
*Solution:* See Figure 11.15. For the maximum value of the bending moment

$$M = \frac{PL}{4} = \frac{18 \times 16}{4} = 72 \text{ kip-ft [98 kN-m]}$$

In Table 9.3, find the value of  $S$  for the shape as 38.6 in.<sup>3</sup> [632 × 10<sup>3</sup> mm<sup>3</sup>]. Thus, the maximum stress is

$$f = \frac{M}{S} = \frac{72 \times 12}{38.6} = 22.4 \text{ ksi [154 MPa]}$$

and it occurs as shown in Figure 11.15*d*. Note that this stress condition occurs only at the beam section at midspan. Figure 11.15*e* shows the form of the deformations that accompany the stress condition. This stress level is well below the elastic stress limit (yield point) and, in this example, below the allowable stress of 24 ksi.

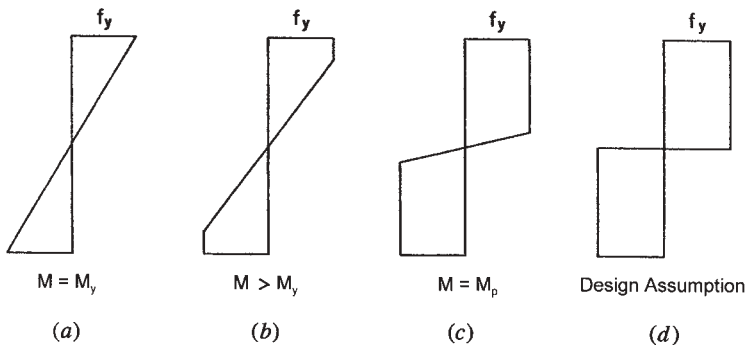


**Figure 11.15** Example 12: elastic behavior of the beam.

The limiting moment that may be expressed in allowable stress terms is that which occurs when the maximum flexural stress reaches the yield stress limit, as stated before in the expression for  $M_y$ . This condition is illustrated by the stress diagram in Figure 11.16a.

If the loading (and the bending moment) that causes the yield limit flexural stress is increased, a stress condition like that illustrated in Figure 11.16b begins to develop as the ductile material deforms plastically. This spread of the higher stress level over the beam cross section indicates the development of a resisting moment in excess of  $M_y$ . With a high level of ductility, a limit for this condition takes a form, as shown in Figure 11.16c, and the limiting resisting moment is described as the *plastic moment*, designated  $M_p$ . Although a small percentage of the cross section near the beam's neutral axis remains in an elastic stress condition, its effect on the development of the resisting moment is quite negligible. Thus, it is assumed that the full plastic limit is developed by the condition shown in Figure 11.16d.

Attempts to increase the bending moment beyond the value of  $M_p$  will result in large rotational deformation, with the beam acting as though it were hinged (pinned) at this location. For practical purposes, therefore, the resisting moment capacity of the ductile beam is considered to be exhausted with the attaining of the plastic moment; additional loading will merely cause a free rotation at the location of the plastic moment. This location is thus described as a *plastic hinge* (see Figure 11.17), and its effect on beams and frames is discussed further in what follows.



**Figure 11.16** Progression of development of bending stress, from the elastic to the plastic range of stress magnitude.

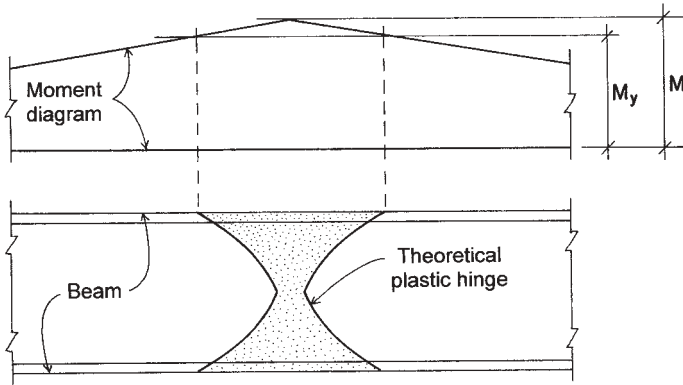


Figure 11.17 Development of the plastic hinge.

In a manner similar to that for elastic stress conditions, the value of the resisting plastic moment is expressed as

$$M = F_y \times Z$$

The term  $Z$  is called the *plastic section modulus* and its value is determined as follows:

Referring to Figure 11.18, which shows a W-shape subjected to a level of flexural stress corresponding to the fully plastic section (Figure 11.16d),

$A_u$  = the upper area of the cross section, above the neutral axis

$y_u$  = distance of the centroid of  $A_u$  from the neutral axis

$A_l$  = the lower area of the cross section, below the neutral axis

$y_l$  = distance of the centroid of  $A_l$  from the neutral axis

For equilibrium of the internal forces on the cross section (the resulting forces  $C$  and  $T$  developed by the flexural stresses), the condition can be expressed as

$$\Sigma F_h = 0$$

or

$$[A_u \times (+f_y)] + [A_l \times (-f_y)] = 0$$

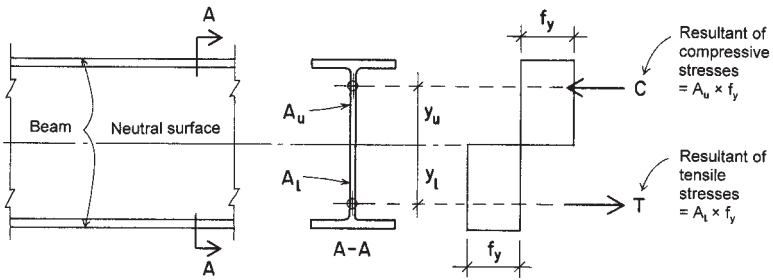


Figure 11.18 Development of the plastic resisting moment.

and thus,

$$A_u = A_l$$

This shows that the plastic stress neutral axis divides the cross section into equal areas, which is apparent for symmetrical sections, but it applies to unsymmetrical sections as well. The resisting moment equals the sum of the moments of the stresses; thus, the value for  $M_p$  may be expressed as

$$M_p = (A_u \times f_y \times y_u) + (A_l \times f_y \times y_l)$$

or

$$M_p = f_y [(A_u \times y_u) + (A_l \times y_l)]$$

or

$$M_p = f_y \times Z$$

and the quantity  $[(A_u \times y_u) + (A_l \times y_l)]$  is the property of the cross section defined as the plastic section modulus, designated  $Z$ .

Using the expression for  $Z$  just derived, its value for any cross section can be computed. However, values of  $Z$  are tabulated in the AISC Manual (Ref. 3) for all rolled sections used as beams.

Comparison of the values for  $S_x$  and  $Z_x$  for the same W shape will show that the values for  $Z$  are larger. This presents an opportunity to compare the fully plastic resisting moment to the yield stress limiting moment by elastic stress.



**Example 13.** A simple beam consisting of a W 21 × 57 is subjected to bending. Find the limiting moments (a) based on elastic stress conditions and a limiting stress of  $F_y = 36$  ksi, and (b) based on full development of the plastic moment.

*Solution:* For (a), the limiting moment is expressed as

$$M_y = F_y \times S_x$$

From Table 9.3, for the W 21 × 57,  $S_x$  is 111 in.<sup>3</sup>, so the limiting moment is

$$M_y = 36 \times 111 = 3996 \text{ kip-in.} \quad \text{or} \quad \frac{3996}{12} = 333 \text{ kip-ft}$$

For (b), the limiting plastic moment, using the value of  $Z_x = 129$  in.<sup>3</sup> from Table 9.3, is

$$M_p = F_y \times Z = 36 \times 129 = 4644 \text{ kip-in.} \quad \text{or} \quad \frac{4644}{12} = 387 \text{ kip-ft}$$

The increase in moment resistance represented by the plastic moment indicates an increase of  $387 - 333 = 54$  kip-ft, or a percentage gain of  $(54/333)(100) = 16.2\%$ .

Advantages of use of the plastic moment for design are not so simply demonstrated. A different process must be used regarding safety factors—and if the load and resistance factor design (LRFD) method is used, a whole different approach. In general, little difference will be found for the design of simple beams. Significant differences occur with continuous beams, restrained beams, and rigid column/beam frames, as demonstrated in the following discussion.

#### **Problem 11.10.A**

A simple-span, uniformly loaded beam consists of a W 18 × 50 with  $F_y = 36$  ksi. Find the percentage of gain in the limiting bending moment if a fully plastic condition is assumed, instead of a condition limited by elastic stress.

#### **Problem 11.10.B**

A simple-span, uniformly loaded beam consists of a W 16 × 45 with  $F_y = 36$  ksi. Find the percentage of gain in the limiting bending moment

if a fully plastic condition is assumed, instead of a condition limited by elastic stress.

### Plastic Hinging in Continuous and Restrained Beams

The general behavior of restrained and continuous beams is presented in Chapter 5. Figure 11.19 shows a uniformly distributed load of  $w$  lb/ft on a beam that is fixed (restrained from rotation) at both ends. The moment induced by this condition is distributed along the beam length in a manner represented by the moment diagram for a simple-span beam (see Figure 4.20, Case 2), consisting of a symmetrical parabola with maximum height (maximum moment) of  $wL^2/8$ . For other conditions of support or continuity, this distribution of moment will be altered; however, the total moment remains the same.

In Figure 11.19a, the fixed ends result in the distribution shown beneath the beam, with maximum end moments of  $wL^2/12$  and a moment at the center of  $wL^2/8 - wL^2/12 = wL^2/24$ . This distribution will continue as long as stress does not exceed the yield limit. Thus, the limiting condition

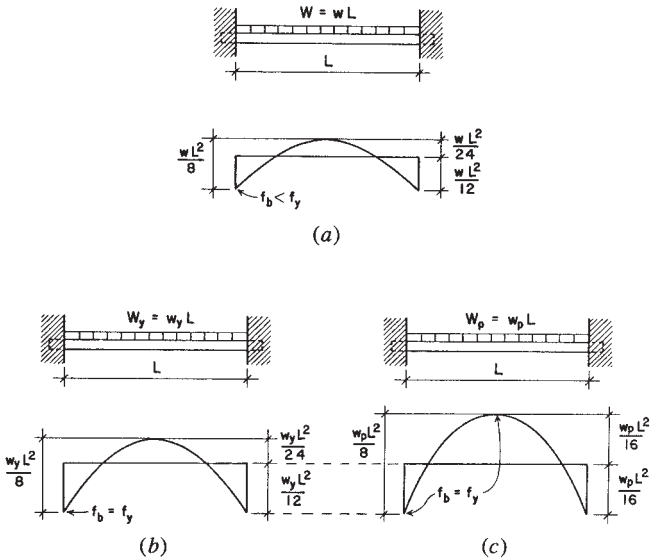


Figure 11.19 Development of the fully plastic restrained beam.

for elastic conditions is shown in Figure 11.19*b*, with a load limit of  $w_y$  corresponding to the yield stress limit.

Once the flexural stress at the point of maximum moment reaches the fully plastic state, further loading will result in the development of a plastic hinge, and the resisting moment at that location will not exceed the plastic moment for any additional loadings. However, additional loading of the beam may be possible, with the moment at the plastic hinge remaining constant; this may proceed until an additional fully plastic condition occurs at some other location.

For the beam in Figure 11.19, the plastic limit for the beam is shown in Figure 11.19*c*; this condition is arrived at when both maximum moments are equal to the beam's plastic limit. Thus, if  $2(M_p) = w_p L^2/8$ , then the plastic limit ( $M_p$ ) is equal to  $w_p L/16$ , as shown in the figure. The following is a simple example of the form of investigation that is carried out in the LRFD method.

**Example 14.** A beam with fixed ends carries a uniformly distributed load. The beam consists of a W 21 × 57 of A36 steel with  $F_y = 36$  ksi. Find the value for the expression of the uniform load if (a) the limit for flexure is the limit for elastic behavior of the beam, and (b) the beam is permitted to develop the fully plastic moment at critical moment locations.

*Solution:* This is the same shape for which limiting yield stress moment and limiting fully plastic moment were found in Example 13. As found there, these are:

$$M_y = 333 \text{ kip-ft (the elastic stress limit at yield)}$$

$$M_p = 387 \text{ kip-ft (the fully plastic moment)}$$

- (a) Referring to Figure 11.19*b*, maximum moment for elastic stress is  $wL^2/12$ , and equating this to the limiting value for moment,

$$M_y = 333 = \frac{w_y L^2}{12}$$

from which

$$w_y = \frac{333 \times 12}{L^2} = \frac{3996}{L^2} \text{ (in kip-ft units)}$$

- (b) Referring to Figure 11.19c, the maximum value for plastic moments with hinging at the fixed ends is  $wL^2/16$ , and equating this to the limiting value for moment,

$$M_p = 387 = \frac{w_p \times L^2}{16}$$

from which

$$w_p = \frac{387 \times 16}{L^2} = \frac{6192}{L^2} \text{ (in kip-ft units)}$$

Combining the increase due to the plastic moment with the effect of the redistribution of moments due to plastic hinging, the total increase is  $6192 - 3996 = 2196/L^2$ , and the percentage gain is

$$\frac{2196}{3996} \times 100 = 55\%$$

This is a substantially greater gain than that indicated in Example 13 (only 16.2%), where difference in moments alone was considered. It is this combined effect that is significant for applications of plastic analysis and the LRFD method for continuous and rigid frame structures.

***Problem 11.10.C***

If the beam in Problem 11.10.A has fixed ends instead of simple supports, find the percentage gain in load-carrying capacity if a fully plastic condition is assumed, rather than a condition limited by elastic stress.

***Problem 11.10.D***

If the beam in Problem 11.10.B has fixed ends instead of simple supports, find the percentage gain in load-carrying capacity if a fully plastic condition is assumed, rather than a condition limited by elastic stress.

# 12

---

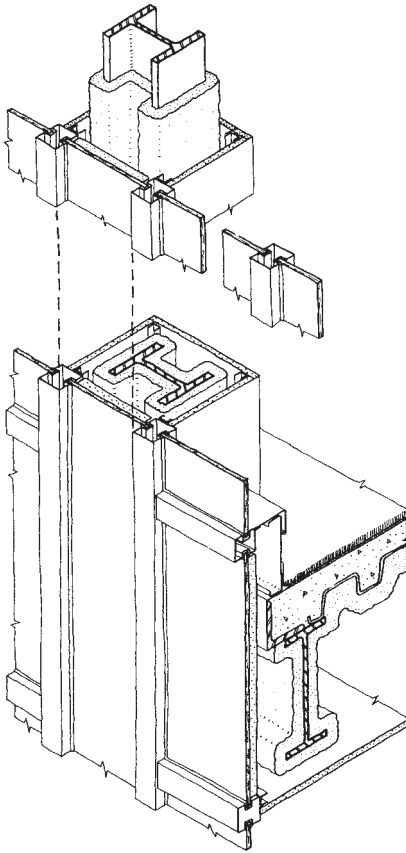
## COMPRESSION MEMBERS

---

Compression is developed in a number of ways in structures, including the compression component that accompanies the development of internal bending. In this section, consideration is given to elements whose primary purpose is resistance of compression. In general, this includes truss members, piers, bearing walls, and bearing footings, although major treatment here is given to columns, which are linear compression members. Building columns may be free-standing architectural elements, with the structural column itself exposed to view. However, for fire or weather protection, the structural column must often be incorporated into other construction (see Figure 12.1) and may in some cases be fully concealed from view.

### 12.1 SLENDERNESS EFFECTS

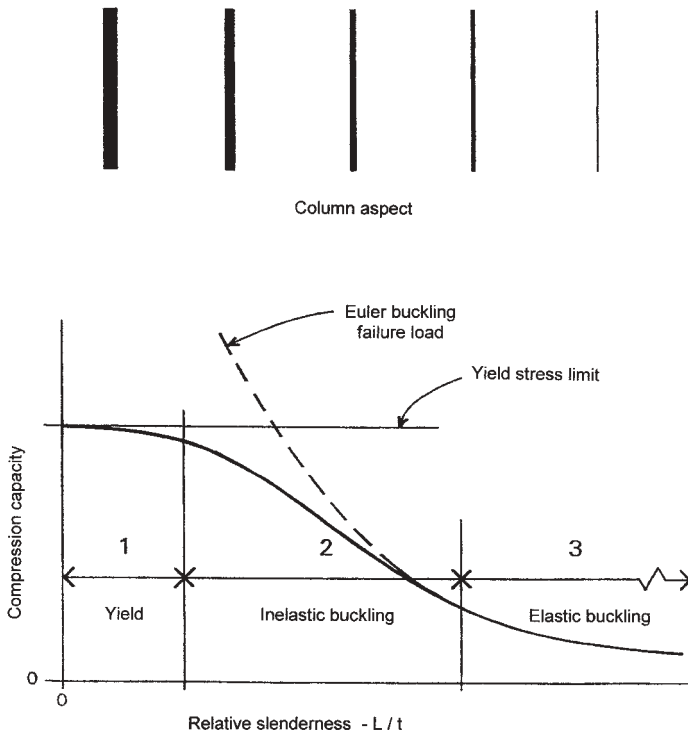
Structural columns are for the most part quite slender, although the specific aspect of slenderness (called *relative slenderness*) must be considered (see Figure 12.2). At the extremes, the limiting situations are those



**Figure 12.1** Steel column incorporated in the construction of a multistory building. Primarily carrying a vertical compression load, the column also serves a major function as part of the general steel framework for the building, typically supporting steel beams as shown in the illustration here.

of the very stout or short column that fails by crushing, and the very slender or tall column that fails by lateral buckling.

The two basic limiting response mechanisms—crushing and buckling—are entirely different in nature. Crushing is a stress resistance phenomenon, and its limit is represented on the graph in Figure 12.2 as a horizontal line, basically established by the compression resistance of the material and the amount of material (area of the cross section) in the compression member. This behavior is limited to the range labeled zone 1 in Figure 12.2.



**Figure 12.2** Effect of column slenderness on axial compression capacity.

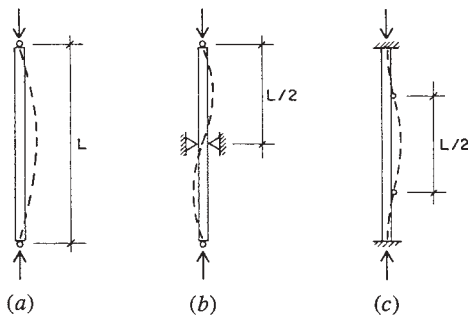
Buckling actually consists of lateral deflection in bending, and its extreme limit is affected by the bending stiffness of the member, as related to the stiffness of the material (modulus of elasticity) and to the geometric property of the cross section directly related to deflection—the moment of inertia of the cross-sectional area. The classic expression for elastic buckling is stated in the form of the equation developed by Euler:

$$P = \frac{\pi^2 EI}{L^2}$$

The curve produced by this equation is of the form shown in Figure 12.2. It closely predicts the failure of quite slender compression members in the range labeled zone 3 in Figure 12.2.

In fact, most building columns fall somewhere between very stout and very slender; in other words, in the range labeled zone 2 in Figure 12.2. Their behavior, therefore, is one of an intermediate form, somewhere between pure stress response and pure elastic buckling. Predictions of structural response in this range must be established by empirical equations that somehow make the transition from the horizontal line to the Euler curve. Equations currently used are explained in Section 12.2 for wood columns and in Section 12.3 for steel columns.

Buckling may be affected by constraints, such as lateral bracing that prevents sideways movement, or support conditions that restrain the rotation of the member's ends. Figure 12.3a shows the case for the member that is the general basis for response as indicated by the Euler formula. This form of response can be altered by lateral constraints, as shown in Figure 12.3b, that result in a multimode deflected shape. The member in Figure 12.3c has its ends restrained against rotation (described as a fixed end). This also modifies the deflected shape, and thus, the value produced from the buckling formula. One method used for adjustment is to modify the column length used in the buckling formula to that occurring between inflection points; thus, the *effective buckling length* for the columns in both Figures 12.3b and c would be one half that of the true column total length. Inspection of the Euler formula will indicate the impact of this modified length on buckling resistance.



**Figure 12.3** Form of buckling of a column as affected by various end conditions and lateral constraint.

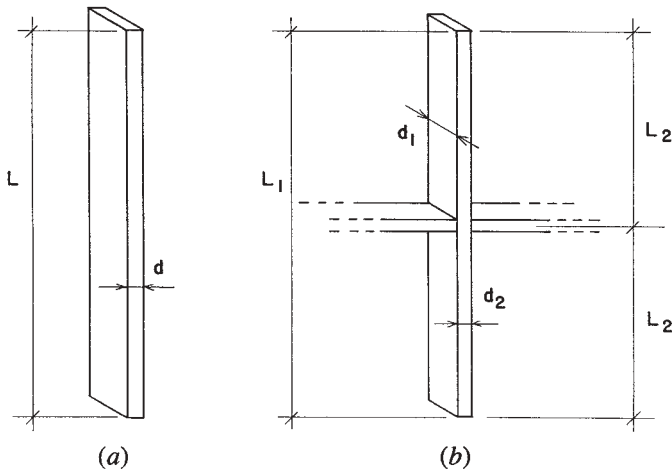


## 12.2 WOOD COLUMNS

The wood column that is used most frequently is the *solid-sawn section* consisting of a single piece of wood, square or oblong in cross section. Single piece round columns are also used as building columns or foundation piles. This section deals with these common elements and some other special forms used as compression members in building construction.

For all columns, a fundamental consideration is the column slenderness. For the solid-sawn wood column, slenderness is established as the ratio of the laterally unbraced length to the least side dimension, or  $L/d$  (Figure 12.4a). The unbraced length (height) is typically the overall vertical length of the column. However, it takes very little force to brace a column from moving sideways (buckling under compression), so that where construction constrains a column, there may be a shorter unbraced length on one or both axes (Figure 12.4b).

An important point to make here is that the short compression member is limited by stress resistance, while the very slender member is limited essentially by its stiffness—that is, by the resistance of the member



**Figure 12.4** Determination of relative slenderness for investigation of buckling. (a) The relative slenderness for this column is determined as  $L/d$ . (b) For buckling in the direction of the broader dimension ( $d_1$ ), slenderness is determined as  $L_1/d_1$ , while for buckling in the direction of the narrow dimension ( $d_2$ ), slenderness is determined as  $L_2/d_2$ .

to lateral deflection. Deflection resistance is measured in terms of the stiffness (modulus of elasticity) of the material of the column and the geometric property of its cross section (moment of inertia). It is, therefore, *stress* that establishes the limit at the low range of relative stiffness and *stiffness* (modulus of elasticity, slenderness ratio) that establishes the limit at extreme values of relative stiffness.

Most building columns, however, fall in a range of stiffness that is transitional between these extremes (Zone 2, as described in Section 12.1). It becomes necessary, therefore, to establish some means for determination of the axial capacity of columns that treats the complete range—from very short to very tall, and all points between. Current column design standards establish complex formulas for description of a single curve that makes the full transition of column behavior related to slenderness. It is important to understand the effect of the variables in these formulas, although for practical design work, use is generally made of one or more design aids that permit shortcuts to pragmatic answers.

Excessively slender building columns are neither safe nor practical. In fact, the point of separation between Zones 2 and 3 in Figure 12.2 generally represents a practical limit for maximum slenderness for columns. Some codes specify a limit, but this degree of slenderness is a general guide for designers. For wood columns, a limit used in the past was a slenderness ratio of 1/50.

### Column Load Capacity

The following discussion presents materials from the NDS (*National Design Specification*—Ref. 2) for design of axially loaded columns. The basic formula for determination of the capacity of a wood column, based on the working stress method, is

$$P = (F_c^*)(C_p)(A)$$

in which

$A$  = area of the column cross section

$F_c^*$  = the allowable design value for compression parallel to the grain, as modified by applicable factors, except  $C_p$

$C_p$  = the column stability factor

$P$  = the allowable column axial compression load

The column stability factor is determined as follows:

$$C_p = \frac{1 + (F_{cE}/F_c^*)}{2c} - \sqrt{\left[ \frac{1 + (F_{cE}/F_c^*)}{2c} \right]^2 - \frac{F_{cE}/F_c^*}{c}}$$

in which

$F_{cE}$  = the Euler buckling stress, as determined by the formula below

$c$  = 0.8 for sawn lumber, 0.85 for round poles, 0.9 for glued-laminated timbers

For the buckling stress:

$$F_{cE} = \frac{(K_{cE})(E)}{(L_e/d)^2}$$

in which

$K_{cE}$  = 0.3 for visually graded lumber and machine evaluated lumber, 0.418 for machine stress rated lumber and glued-laminated timber

$E$  = modulus of elasticity for the wood species and grade

$L_e$  = the effective length (unbraced height as modified by any factors for support conditions) of the column

$d$  = the column cross-sectional dimension (column width) measured in the direction that buckling occurs

The values to be used for the effective column length and the corresponding column width should be considered as discussed for the conditions displayed in Figure 12.4. For a basic reference, the buckling phenomenon typically uses a member that is pinned at both ends and prevented from lateral movement only at the ends, for which no modification for support conditions is made; this is a common condition for wood columns. The NDS presents methods for modified buckling lengths that are essentially similar to those used for steel design (see Section 12.3). These are illustrated for steel columns in Section 12.3, but not here.

The following examples illustrate the use of the NDS formulas for columns.

**Example 1.** A wood column consists of a  $6 \times 6$  of Douglas fir larch, No. 1 grade. Find the safe axial compression load for unbraced lengths of: (a) 2 ft, (b) 8 ft, (c) 16 ft.

*Solution:* From the NDS (Ref. 2), find values of  $F_c = 1000$  psi and  $E = 1,600,000$  psi. With no basis for adjustment given, the  $F_c$  value is used directly as the  $F_c^*$  value in the column formulas.

For (a):  $L/d = 2(12)/5.5 = 4.36$ . Then

$$F_{cE} = \frac{(K_{cE})(E)}{(L_e/d)^2} = \frac{(0.3)(1,600,000)}{(4.36)^2} = 25,250 \text{ psi}$$

$$\frac{F_{cE}}{F_c^*} = \frac{25,250}{1000} = 25.25$$

$$C_p = \frac{1 + 25.25}{1.6} - \sqrt{\left[ \frac{1 + 25.25}{1.6} \right]^2 - \frac{25.25}{0.8}} = 0.993$$

And the allowable compression load is

$$P = (F_c^*)(C_p)(A) = (1000)(0.993)(5.5)^2 = 30,038 \text{ lb}$$

For (b):  $L/d = 8(12)/5.5 = 17.45$ , for which  $F_{cE} = 1576$  psi,  $F_{cE}/F_c^* = 1.576$ ,  $C_p = 0.821$ , and thus,

$$P = (1000)(0.821)(5.5)^2 = 24,835 \text{ lb}$$

For (c):  $L/d = 16(12)/5.5 = 34.9$ , for which  $F_{cE} = 394$  psi,  $F_{cE}/F_c^* = 0.394$ ,  $C_p = 0.355$ , and thus,

$$P = (1000)(0.355)(5.5)^2 = 10,736 \text{ lb}$$

**Example 2.** Wood  $2 \times 4$  elements are to be used as vertical compression members to form a wall (ordinary stud construction). If the wood is Douglas fir larch, stud grade, and the wall is 8.5 ft high, what is the column load capacity of a single stud?

*Solution:* It is assumed that the wall has a covering attached to the studs or blocking between the studs to brace them on their weak (1.5-in.

dimension) axis. Otherwise, the practical limit for the height of the wall is  $50 \times 1.5 = 75$  in. Therefore, using the larger dimension,

$$\frac{L}{d} = \frac{8.5(12)}{3.5} = 29.14$$

From the NDS (Ref. 2):  $F_c = 850$  psi,  $E = 1,400,000$  psi, with the value for  $F_c$  adjusted to  $1.05(850) = 892.5$  psi. Then

$$F_{cE} = \frac{(K_{cE})(E)}{(L_e/d)^2} = \frac{(0.3)(1,400,000)}{(29.14)^2} = 495 \text{ psi}$$

$$\frac{F_{cE}}{F_c^*} = \frac{495}{892.5} = 0.555$$

$$C_p = \frac{1.555}{1.6} - \sqrt{\left[ \frac{1.555}{1.6} \right]^2 - \frac{0.555}{0.8}} = 0.471$$

$$P = (F_c^*)(C_p)(A) = (892.5)(0.471)(1.5 \times 3.5) = 2207 \text{ lb}$$

### Problems 12.2.A–C

Find the allowable axial compression load for the following wood columns. Use  $F_c = 700$  psi and  $E = 1,300,000$  psi.

Column	Nominal Size (in.)	Unbraced Length	
		(ft)	(mm)
A	6 × 6	10	3.05
B	8 × 8	18	5.49
C	10 × 10	14	4.27

## 12.3 STEEL COLUMNS

Steel compression members range from small, single-piece columns and truss members to huge, built-up sections for high-rise buildings and large tower structures. The basic column function is one of simple compressive force resistance, but is often complicated by the effects of buckling and the possible presence of bending actions.

## Column Shapes

For modest load conditions, the most frequently used shapes are the round pipe, the rectangular tube, and the H-shaped rolled section—most often the W shapes that approach a square form (see Figure 12.5). Accommodation of beams for framing is most easily achieved with W-shapes of 10-in. or larger nominal depth.

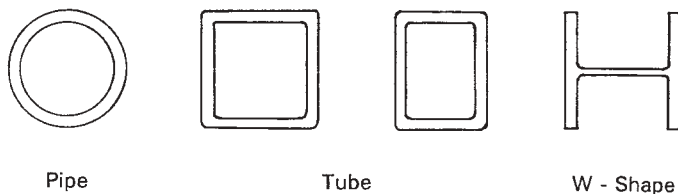
For various reasons, it is sometimes necessary to make up a column section by assembling two or more individual steel elements. The customized assemblage of built-up sections is usually costly, so a single piece is typically favored if one is available.

## Slenderness and End Conditions

The general effect of slenderness on the axial compression load capacity of columns is discussed in Section 12.1. For steel columns, the value of the allowable stress in compression is determined from formulas in the AISC Specification (found in Ref. 3); it includes variables of the steel yield stress and modulus of elasticity, the relative slenderness of the column, and special considerations for any bracing or rotational restraint at the column ends.

Column slenderness is determined as the ratio of the column unbraced length to the radius of gyration of the column section:  $L/r$ . Effects of end restraint are considered by use of a modifying factor ( $K$ ) resulting in some reduced or magnified value for  $L$  (see Figure 12.6). The modified slenderness is thus expressed as  $KL/r$ .

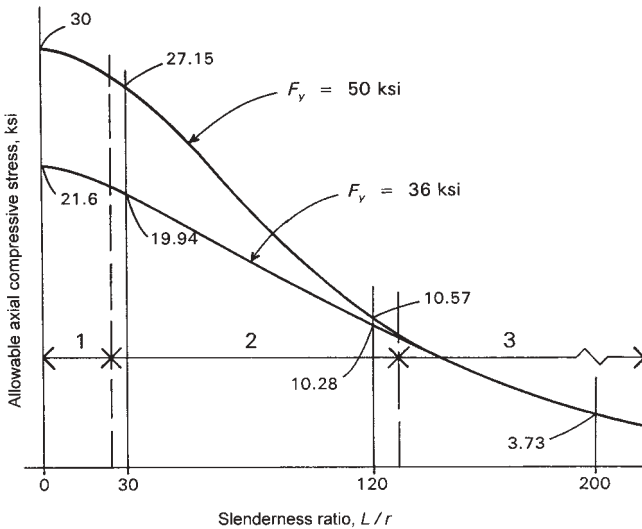
Figure 12.7 is a graph of the allowable axial compressive stress for a column for two grades of steel with  $F_y$  of 36 ksi and 50 ksi. Values for full number increments of  $KL/r$  are also given in Table 12.1. Values indicated on the graph curve for 36 ksi may be compared with those obtained for the corresponding  $L/r$  values in Table 12.1.



**Figure 12.5** Common shapes of cross sections for steel columns.

Buckled shape of column is shown by dashed line	(a)	(b)	(c)	(d)	(e)	(f)
Theoretical $K$ value	0.5	0.7	1.0	1.0	2.0	2.0
Recommended design value when ideal conditions are approximated	0.65	0.80	1.2	1.0	2.10	2.0
End condition code						
	Rotation fixed and translation fixed Rotation free and translation fixed Rotation fixed and translation free Rotation free and translation free					

**Figure 12.6** Determination of modified effective column length for buckling of steel columns. Reproduced from the *Manual of Steel Construction*, 8th edition, with permission of the publisher, the American Institute of Steel Construction, Chicago, IL.



**Figure 12.7** Allowable axial compressive stress for steel columns as a function of yield limit and column slenderness. Range 1 involves essentially a yield stress failure condition. Range 3 involves essentially an elastic buckling limit based on steel stiffness, which is independent of stress magnitude. Range 2 is the inelastic buckling condition, which is transitional between the other two ranges.

**TABLE 12.1 Allowable Unit Stress,  $F_a$ , for Columns of A36 Steel (ksi)<sup>a</sup>**

$KL/r$	$F_a$	$KL/r$	$F_a$	$KL/r$	$F_a$	$KL/r$	$F_a$	$KL/r$	$F_a$	$KL/r$	$F_a$	$KL/r$	$F_a$	$KL/r$	$F_a$
1	21.56	26	20.22	51	18.26	76	15.79	101	12.85	126	9.41	151	6.55	176	4.82
2	21.52	27	20.15	52	18.17	77	15.69	102	12.72	127	9.26	152	6.46	177	4.77
3	21.48	28	20.08	53	18.08	78	15.58	103	12.59	128	9.11	153	6.38	178	4.71
4	21.44	29	20.01	54	17.99	79	15.47	104	12.47	129	8.97	154	6.30	179	4.66
5	21.39	30	19.94	55	17.90	80	15.36	105	12.33	130	8.84	155	6.22	180	4.61
6	21.35	31	19.87	56	17.81	81	15.24	106	12.20	131	8.70	156	6.14	181	4.56
7	21.30	32	19.80	57	17.71	82	15.13	107	12.07	132	8.57	157	6.06	182	4.51
8	21.25	33	19.73	58	17.62	83	15.02	108	11.94	133	8.44	158	5.98	183	4.46
9	21.21	34	19.65	59	17.53	84	14.90	109	11.81	134	8.32	159	5.91	184	4.41
10	21.16	35	19.58	60	17.43	85	14.79	110	11.67	135	8.19	160	5.83	185	4.36
11	21.10	36	19.50	61	17.33	86	14.67	111	11.54	136	8.07	161	5.76	186	4.32
12	21.05	37	19.42	62	17.24	87	14.56	112	11.40	137	7.96	162	5.69	187	4.27
13	21.00	38	19.35	63	17.14	88	14.44	113	11.26	138	7.84	163	5.62	188	4.23
14	20.95	39	19.27	64	17.04	89	14.32	114	11.13	139	7.73	164	5.55	189	4.18
15	20.89	40	19.19	65	16.94	90	14.20	115	10.99	140	7.62	165	5.49	190	4.14
16	20.83	41	19.11	66	16.84	91	14.09	116	10.85	141	7.51	166	5.42	191	4.09
17	20.78	42	19.03	67	16.74	92	13.97	117	10.71	142	7.41	167	5.35	192	4.05
18	20.72	43	18.95	68	16.64	93	13.84	118	10.57	143	7.30	168	5.29	193	4.01
19	20.66	44	18.86	69	16.53	94	13.72	119	10.43	144	7.20	169	5.23	194	3.97
20	20.60	45	18.78	70	16.43	95	13.60	120	10.28	145	7.10	170	5.17	195	3.93
21	20.54	46	18.70	71	16.33	96	13.48	121	10.14	146	7.01	171	5.11	196	3.89
22	20.48	47	18.61	72	16.22	97	13.35	122	9.99	147	6.91	172	5.05	197	3.85
23	20.41	48	18.53	73	16.12	98	13.23	123	9.85	148	6.82	173	4.99	198	3.81
24	20.35	49	18.44	74	16.01	99	13.10	124	9.70	149	6.73	174	4.93	199	3.77
25	20.28	50	18.35	75	15.90	100	12.98	125	9.55	150	6.64	175	4.88	200	3.73

Source: Adapted from data in the *Manual of Steel Construction*, 8th edition, with permission of the publishers, American Institute of Steel Construction, Chicago, IL.

<sup>a</sup>Value of  $K$  is taken as 1.0.  $F_y = 36$  ksi.

It may be noted, in Figure 12.7, that the two curves converge at an  $L/r$  value of approximately 125. This is a manifestation of the fact that elastic buckling takes over beyond this point, making the material's stiffness (modulus of elasticity) the only significant property for stiffness values higher than about 125. Thus, the usefulness of the higher grade steel becomes moot for very slender members.

For practical reasons, most building columns tend to have relative stiffnesses between about 50 and 100, with only very heavily loaded columns falling below this, and most designers avoid using extremely slender columns.



### Safe Axial Loads for Steel Columns

The allowable axial load for a column is computed by multiplying the allowable stress ( $F_a$ ) by the cross-sectional area of the column. The following examples demonstrate the process. For single-piece columns, a more direct process consists of using column load tables. For built-up sections, however, it is necessary to compute the properties of the section.

**Example 3.** A W 12 × 53 is used as a column with an unbraced length of 16 ft [4.88 m]. Compute the allowable load.

*Solution:* Referring to Table 9.3,  $A = 15.6 \text{ in.}^2$ ,  $r_x = 5.23 \text{ in.}$ , and  $r_y = 2.48 \text{ in.}$  If the column is unbraced on both axes, it is limited by the lower  $r$  value for the weak axis. With no stated end conditions, Case (d) in Figure 12.6 is assumed, for which  $K = 1.0$ ; that is, no modification is made. (This is the unmodified condition.) Thus, the relative stiffness is computed as

$$\frac{KL}{r} = \frac{1 \times 16 \times 12}{2.48} = 77.4$$

In design work, it is usually considered acceptable to round the slenderness ratio off to the nearest whole number. Thus, with a  $KL/r$  value of 77, Table 12.1 yields a value for  $F_a$  of 15.69 ksi. The allowable load for the column is then

$$P = (F_a)(A) = (15.69)(15.6) = 244.8 \text{ kips [1089 kN]}$$

**Example 4.** Compute the allowable load for the column in Example 3 if the top is pinned but prevented from lateral movement and the bottom is totally fixed.

*Solution:* Referring to Figure 12.6, this is Case (b), and the modifying factor is 0.8. Then:

$$\frac{KL}{r} = \frac{0.8 \times 16 \times 12}{2.48} = 62$$

From Table 12.1,  $F_a = 17.24 \text{ ksi}$ , and thus,

$$P = (17.24)(15.6) = 268.9 \text{ kips [1196 kN]}$$

The following example illustrates the situation in which a W-shape is braced differently on its two axes.

**Example 5.** Figure 12.8a shows an elevation of the steel framing at the location of an exterior wall. The column is laterally restrained but rotationally free at the top and bottom in both directions (end condition as for Case (d) in Figure 12.6). With respect to the  $x$ -axis of the section, the column is laterally unbraced for its full height. However, the existence of the horizontal framing in the wall plane provides lateral bracing with respect to the  $y$ -axis of the section; thus, the buckling of the column in this direction takes the form shown in Figure 12.8b. If the column is a W 12  $\times$  53 of A36 steel,  $L_1$  is 30 ft, and  $L_2$  is 18 ft, what is the allowable compression load?

*Solution:* The basic procedure here is to investigate both axes separately and to use the highest value for relative stiffness obtained to find the allowable stress. (Note: This is the same section used in Example 1, for which properties were previously obtained from Table 9.3.) For the  $x$ -axis, the situation is Case (d) from Figure 12.6. Thus,

$$x\text{-axis: } \frac{KL}{r} = \frac{1 \times 30 \times 12}{5.23} = 68.8$$

For the  $y$ -axis, the situation is also assumed to be Case (d) from Figure 12.6, except that the deformation occurs in two parts (see Figure 12.8b). The lower part is used, as it has the greater unbraced length. Thus,

$$y\text{-axis: } \frac{KL}{r} = \frac{1 \times 18 \times 12}{2.48} = 87.1, \text{ say } 87$$

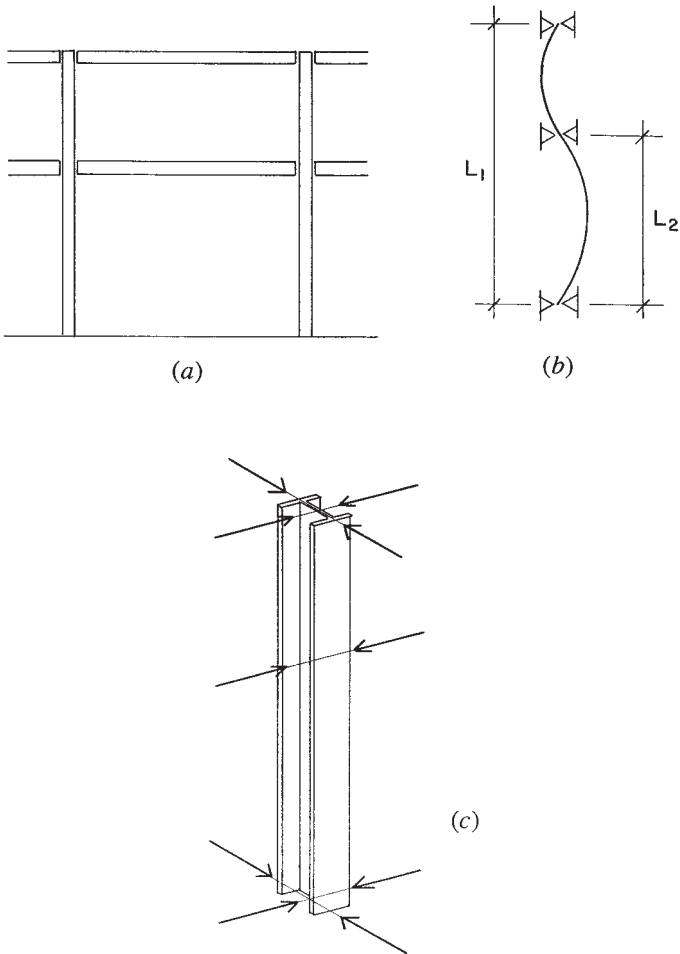
Despite the bracing, the column is still critical on its weak axis. From Table 12.1, the value for  $F_a$  is 14.56 ksi, and the allowable load is thus

$$P = F_a A = (14.56)(15.6) = 227.1 \text{ kips [1010 kN]}$$

For the following problems, use A36 steel with  $F_y = 36$  ksi.

**Problem 12.3.A**

Determine the allowable axial compression load for a W 10  $\times$  49 column with an unbraced height of 15 ft [4.57 m]. Assume  $K = 1.0$ .



**Figure 12.8** Example 5: biaxial bracing conditions for the column.

**Problem 12.3.B**

Determine the allowable axial compression load for a W 12 × 120 column with an unbraced height of 22 ft [6.71 m], if both ends are fixed against rotation and horizontal movement.

***Problem 12.3.C***

Determine the allowable axial compression load in Problem 12.3.A if the conditions are as shown in Figure 12.8 with  $L_1 = 15$  ft [4.6 m] and  $L_2 = 8$  ft [2.44 m].

***Problem 12.3.D***

Determine the allowable axial compression load in Problem 10.3.B if the conditions are as shown in Figure 12.8 with  $L_1 = 40$  ft [12 m] and  $L_2 = 22$  ft [6.7 m].

# 13

---

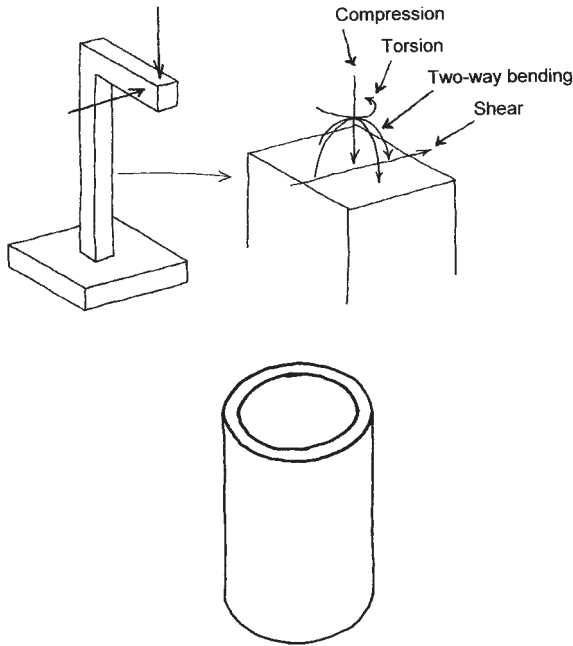
## COMBINED FORCES AND STRESSES

---

Many structural elements perform singular tasks, as simple tension members, compression members, beams, and so on. As such, their stress conditions may be quite simply visualized and investigated. However, it is not uncommon for structural tasks to be multiple for a given structural member, as shown in Figure 13.1. In this case it is necessary to consider both the individual tasks and the effects of their combination. Design of such multitask members may well produce different results from the forms taken by simpler elements. Demonstrated versatility in performing multiple structural tasks establishes some popularity for particular structural elements, such as the cylindrical steel shape (pipe) shown in Figure 13.1. This chapter presents some considerations for combinations of force effects and stresses.

### **13.1 COMBINED ACTION: TENSION PLUS BENDING**

Various situations occur in which both an axial force of tension and a bending moment occur at the same cross section in a structural member.

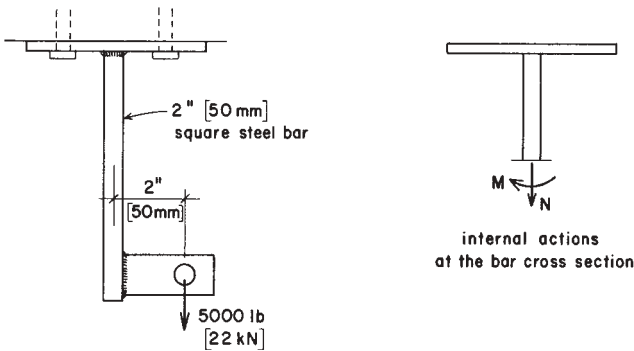


**Figure 13.1** The multifunction structure. In some circumstances, structural elements must perform several different structural functions simultaneously. Such is the case for the vertical post in the structure shown here—possibly the support for a cantilevered sign. Under a combined loading of wind and gravity, the post must resist compression, twisting (torsion), bending in two directions, and lateral shear. The single most effective element for this situation is the steel cylinder, produced for use as piping. No other single element has the versatility and efficiency of the pipe for multiple functions.

Consider the hanger shown in Figure 13.2, in which a 2-in. square steel bar is welded to a plate and the plate is bolted to the bottom of a wood beam. A short piece of steel plate with a hole is welded to the face of the bar, and a load is hung from the hole. In this situation, the steel bar is subjected to combined actions of tension and bending, both of which are produced by the hung load. The bending moment is the product of the load times its eccentricity from the centroid of the bar cross section; thus,

$$M = 5000 \times 2 = 10,000 \text{ in.-lb}$$

$$[22 \times 50 = 1100 \text{ kN-m}]$$



**Figure 13.2** An example of combined tension and bending.

For this simple case, the stresses due to the two phenomena are found separately and added as follows. For the direct tension effect (Figure 13.3a),

$$f_a = \frac{N}{A} = \frac{5}{4} = 1250 \text{ psi [8.8 MPa]}$$

For the bending stress, the section modulus of the bar is found as

$$S = \frac{bd^2}{6} = \frac{2 \times 2^2}{6} = 1.333 \text{ in.}^3 [20.82 \times 10^3 \text{ mm}^3]$$

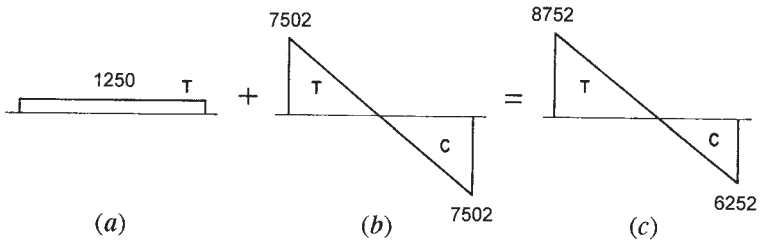
Then, for the bending stress (Figure 13.3b),

$$f_b = \frac{M}{S} = \frac{10,000}{1.333} = 7500 \text{ psi [52.8 MPa]}$$

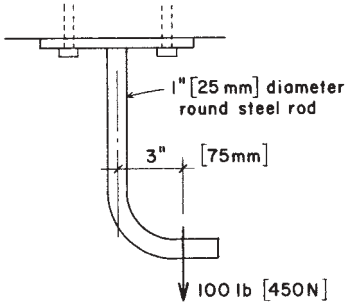
and the stress combinations are (Figure 13.3c)

$$\begin{aligned} \text{maximum } f &= 1250 + 7502 = 8752 \text{ psi [61.6 MPa] (tension)} \\ \text{minimum } f &= 1250 - 7502 = -6252 \text{ psi [44.0 MPa] (compression)} \end{aligned}$$

Although the reversal compression stress is less than the maximum tension stress, there are situations in which it may be critical. The 2-in. square bar in this example is probably capable of developing the compression, but other member cross sections may not be so versatile. A thin bar, for example, may become critical in buckling due to the compression, even though the tension stress is higher.



**Figure 13.3** Consideration for the combined stress shown in Figure 13.2. (a) Direct tension. (b) Bending. (c) Combined stress.



**Figure 13.4** Problem 13.1.

**Problem 13.1.A**

For the hanger rod shown in Figure 13.4, find the maximum and minimum values of the tension stress.

**Problem 13.1.B**

A hanger rod similar to that shown in Figure 13.4 consists of a 1-in. square steel rod. Find the maximum and minimum values of the tension stress if the load is 120 lb and the eccentricity is 2.5 in.

**13.2 COMBINED ACTION: COMPRESSION PLUS BENDING**

Combined actions of compression plus bending produce various effects on structures. In some situations, the actual stress combinations may of themselves be critical, one such case being the development of bearing



stress on soils. At the contact face of a bearing footing and its supporting soil, the “section” for stress investigation is the contact face; that is, the bottom of the footing. The following discussion deals with an approach to this investigation.

Figure 13.5 illustrates a classical approach to the combined direct force and bending moment at a cross section. In this case, the “cross section” is the contact face of the footing bottom with the soil. However the combined force and moment originate, a common analytical technique is to make a transformation into an equivalent eccentric force that produces

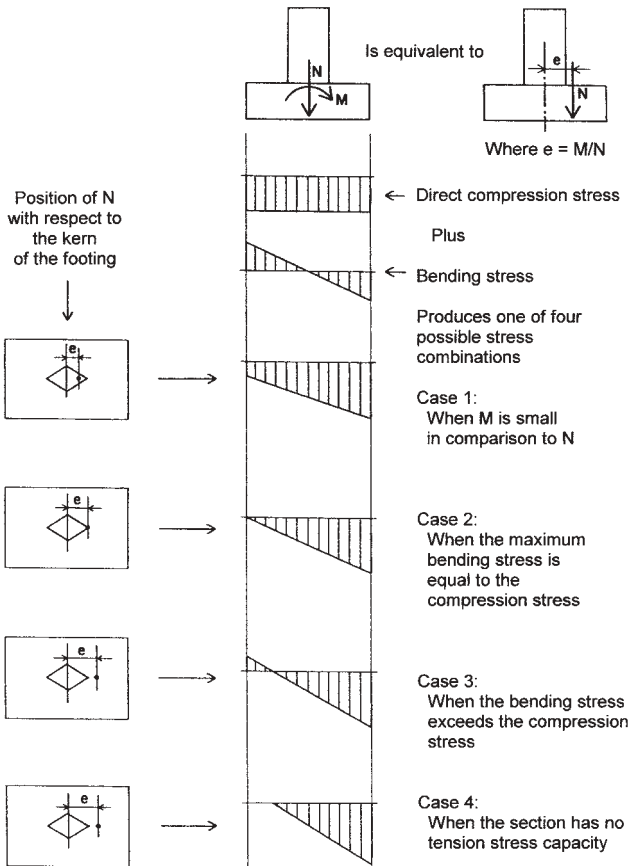


Figure 13.5 Investigation for combined stress due to compression and bending.

the same combined effect. The value for the hypothetical eccentricity  $e$  is established by dividing the moment by the force, as shown in the figure. The net, or combined, stress distribution at the section is visualized as the sum of separate stresses created by the force and the bending. For the limiting stresses at the edges of the section, the general equation for the combined stress is

$$p = (\text{direct stress}) \pm (\text{bending stress})$$

or

$$p = \frac{N}{A} \pm \frac{Nec}{I}$$

Four cases for this combined stress are shown in the figure. The first case occurs when  $e$  is small, resulting in very little bending stress. The section is thus subjected to all compressive stress, varying from a maximum value at one edge to a minimum on the opposite edge.

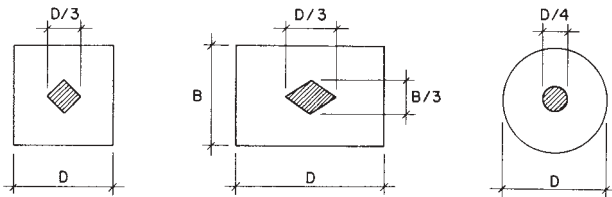
The second case occurs when the two stress components are equal, so that the minimum stress becomes zero. This is the boundary condition between the first and third cases, since any increase in  $e$  will tend to produce some reversal stress (in this situation, tension) on the section.

The second stress case is a significant one for the footing, since tension stress is not possible for the soil-to-footing interface. Case 3 is only possible for a beam or column, or some other continuously solid element. The value for  $e$  that produces Case 2 can be derived by equating the two stress components as follows:

$$\frac{N}{A} = \frac{Nec}{I}, \quad \text{thus,} \quad e = \frac{I}{Ac}$$

This value for  $e$  establishes what is known as the *kern limit* of the section. The kern is defined as a zone around the centroid of the section within which an eccentric force will not cause reversal stress on the section. The form and dimensions of this zone may be established for any geometric shape by application of the derived formula for  $e$ . The kern limit zones for three common geometric shapes are shown in Figure 13.6.

When tension stress is not possible, larger eccentricities of the normal force will produce a so-called *cracked section*, which is shown as Case 4 in Figure 13.5. In this situation, some portion of the cross section becomes unstressed, or cracked, and the compressive stress on the remain-



**Figure 13.6** Kern limits for common shapes.

der of the section must develop the entire resistance to the loading effects of the combined force and moment.

Figure 13.7 shows a technique for the analysis of a cracked section, called the *pressure wedge method*. The “wedge” is a volume that represents the total compressive force as developed by the soil pressure (stress times stressed area). Analysis of the static equilibrium of this wedge produces two relationships that may be used to establish the dimensions of the stress wedge. These relationships are:

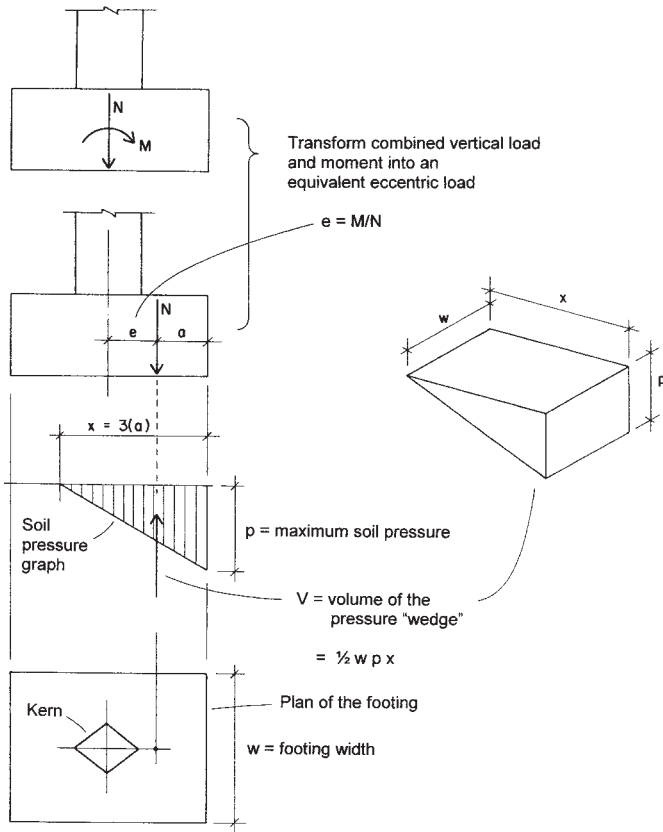
1. The volume of the wedge is equal to the vertical force. (Sum of vertical forces equals zero.)
2. The centroid (center of gravity) of the wedge is located on a vertical line that coincides with the location of the hypothetical eccentric force. (Sum of moments equals zero.)

Referring to Figure 13.7, the three dimensions of the wedge are  $w$  (width of the footing),  $p$  (maximum soil pressure), and  $x$  (limiting dimension of the stressed portion of the cracked section). In this situation, the footing width is known so the definition of the wedge requires only the determination of  $p$  and  $x$ .

For the rectangular section, the centroid of the wedge is at the third point of the triangle. Defining this distance from the edge as  $a$ , as shown in the figure, then  $x$  is equal to three times  $a$ . And it may be observed that  $a$  is equal to half the footing width minus  $e$ . Thus, once the eccentricity is computed, the values of  $a$  and  $x$  can be determined.

The volume of the stress wedge may be expressed in terms of its three dimensions as

$$V = \frac{1}{2} (wp_x)$$



**Figure 13.7** Investigation of combined stress on a cracked section by the pressure wedge method.

With  $w$  and  $x$  established, the remaining dimension of the wedge may then be established by transforming the equation for the volume to

$$p = \frac{2N}{wx}$$

All four cases of combined stress shown in Figure 13.5 will cause rotation (tilt) of the footing due to deformation of the compressible soil. The extent of this rotation and the concern for its effect on the supported structure must be carefully considered in the design of the footing. It is

generally desirable that long-term loads (such as dead load) not develop uneven stress on the footing. Thus, the extreme situations of stress shown in Cases 2 and 4 in Figure 13.5 should be allowed only for short duration loads. See discussion of the cantilever retaining wall in Chapter 6.

**Example 1.** Find the maximum value of soil pressure for a square footing. The axial compression force at the bottom of the footing is 100 kips and the moment is 100 kip-ft. Find the pressure for footing widths of (a) 8 ft, (b) 6 ft, and (c) 5 ft.

*Solution:* The first step is to determine the equivalent eccentricity and compare it to the kern limit for the footing to establish which of the cases shown in Figure 13.5 applies.

- (a) For all parts, the eccentricity is

$$e = \frac{M}{N} = \frac{100}{100} = 1 \text{ ft}$$

For the 8-ft-wide footing the kern limit is  $8/6 = 1.33$  ft; thus, Case 1 applies.

For the computation of soil pressure, the properties of the section (the 8 ft by 8 ft square) must be determined. Thus,

$$A = 8 \times 8 = 64 \text{ ft}^2$$

$$I = \frac{bd^3}{12} = \frac{8 \times 8^3}{12} = 341.3 \text{ ft}^4$$

and the maximum soil pressure is determined as

$$p = \frac{N}{A} + \frac{Mc}{I} = \frac{100}{64} + \frac{100 \times 4}{341.3}$$

$$= 1.56 + 1.17 = 2.73 \text{ ksf}$$

- (b) For the 6-ft-wide footing, the kern limit is 1 ft, the same as the eccentricity. Thus, the situation is stress Case 2 in Figure 13.5, with  $N/A = Mc/I$ . Thus,

$$p = 2 \left( \frac{N}{A} \right) = 2 \left( \frac{100}{36} \right) = 5.56 \text{ ksf}$$

- (c) The eccentricity exceeds the kern limit, and the investigation must be done as illustrated in Figure 13.7.

$$a = \frac{5}{2} - e = 2.5 - 1 = 1.5 \text{ ft}$$

$$x = 3a = 3(1.5) = 4.5 \text{ ft}$$

$$p = \frac{2N}{wx} = \frac{2 \times 100}{5 \times 4.5} = 8.89 \text{ ksf}$$

### Problem 13.2.A

The compression force at the bottom of a square footing is 40 kips [178 kN], and the bending moment is 30 kip-ft [40.7 kN-m]. Find the maximum soil pressure for widths of: (a) 5 ft [1.5 m]; (b) 4 ft [1.2 m].

### Problem 13.2.B

The compression force at the bottom of a square footing is 60 kips [267 kN] and the bending moment is 60 kip-ft [81.4 kN-m]. Find the maximum soil pressure for widths of: (a) 7 ft [2.13 m]; (b) 5 ft [1.5 m].

## 13.3 DEVELOPMENT OF SHEAR STRESS

Shear force generates a lateral, slicing effect in materials. Visualized in two dimensions, this direct effect is as shown in Figure 13.8a. For stability within the material, there will be a counteracting, or reactive, shear stress developed at right angles to the active stress, as shown in Figure 13.8b. The interaction of the active and reactive shears produces both diagonal tension and diagonal compression stresses, as shown in Figures 13.8c and d.

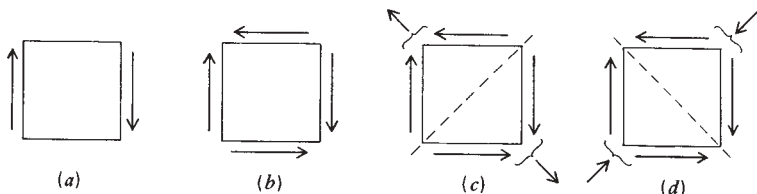


Figure 13.8 Development of shear and resulting diagonal stresses.

Referring to Figure 13.8, it may be observed that:

1. The unit reactive shear stress is equal in magnitude to the unit active shear stress.
2. The diagonal effect (tension or compression) is the vector combination of the active and reactive shear, and thus, has a magnitude of 1.414 times the unit shear.
3. The diagonal stress is developed on a diagonal plane, which has an area 1.414 times that of the area on which the unit shear is developed; thus, the unit diagonal stresses are the same magnitude as the shear stresses.

Accepting the observations just made, it is possible to determine the critical diagonal tension or diagonal compression by simply computing the unit shear stress. However, the direction of these stresses must also be noted.

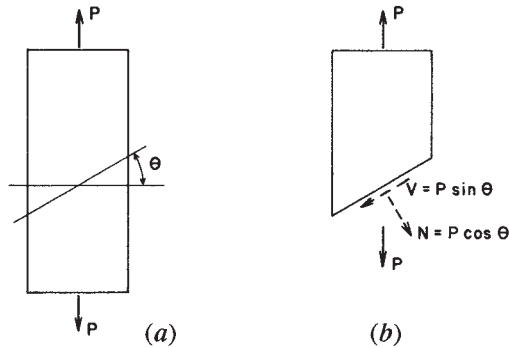
### 13.4 STRESS ON AN OBLIQUE SECTION

In the preceding section, it has been shown that shear produces direct stresses as well as shear stresses. We now demonstrate that direct force produces shear stresses as well as direct stresses. Consider the object shown in Figure 13.9*a*, subjected to a tension force. If a section is cut that is not at a right angle to the force (an oblique section), there may be seen to exist two components of the internal resistance. One component is at a right angle to the cut section and the other is in the plane of the cut section. These two components produce, respectively, direct tension stress ( $f$ ) and shear stress ( $v$ ) at the cut section.

With the angle of the cut section defined as shown in the figure, and the right-angle cross section area defined as  $A$ , these stresses may be expressed as follows:

$$f = \frac{P \cos \Theta}{A / \cos \Theta} = \left( \frac{P}{A} \right) (\cos^2 \Theta)$$

$$v = \frac{P \sin \Theta}{A / \cos \Theta} = \left( \frac{P}{A} \right) (\sin \Theta \cos \Theta)$$



**Figure 13.9** Stresses on an oblique section.

The following may be noted for two special values of the angle  $\Theta$ :

1. For a right-angle section,  $\Theta = 0$ ,  $\cos \Theta = 1$ , and  $\sin \Theta = 0$ , then

$$f = \frac{P}{A} \quad \text{and} \quad v = 0$$

2. When  $\Theta = 45^\circ$ , and  $\cos \Theta = \sin \Theta = 0.707$ , then

$$f = \frac{P/A}{2} \quad \text{and} \quad v = \frac{P/A}{2}$$

It may be demonstrated that the value for the diagonal shear stress on the  $45^\circ$  cut section is the highest value generated by the direct force. Also, the value for the direct stress on an oblique section will always be less than that on a right-angle section, since any value for the cosine of  $\Theta$  will be less than one if  $\Theta$  is greater than zero.

In some situations, the specific value for these stresses on a particular oblique plane may be of concern. The following example demonstrates the use of the derived stress formulas for this situation.

**Example 2.** The wood block shown in Figure 13.10a has its grain at an angle of  $30^\circ$  to the direction of a compression force of 1200 lb on the block. Find the compression and shear stresses on a section that is parallel to the wood grain.



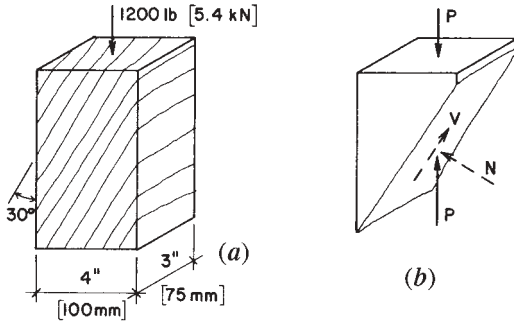


Figure 13.10 Example 2.

*Solution:* Note that, as used in Figure 13.9,  $\Theta = 60^\circ$ . Then, for the free-body diagram shown in Figure 13.10b,

$$N = P \cos 60^\circ, \quad V = P \sin 60^\circ, \quad A = 3 \times 4 = 12.0 \text{ in.}^2$$

Then, applying the data to the stress formulas,

$$f = \left(\frac{P}{A}\right) \cos^2 \Theta = \left(\frac{1200}{12}\right) (0.5)^2 = 25 \text{ psi}$$

$$v = \left(\frac{P}{A}\right) \sin \Theta \cos \Theta = \left(\frac{1200}{12}\right) (0.5)(0.866) = 43.3 \text{ psi}$$

**Problems 13.4.A–C**

A structural member such as that in Figure 13.9 has a right-angle cross section of 10 in.<sup>2</sup> and is loaded in compression with a force of 10,000 lb. Find the direct and shear stresses on an oblique section with  $\Theta$  as shown in Figure 13.9 equal to: (A) 15°, (B) 20°, (C) 30°.

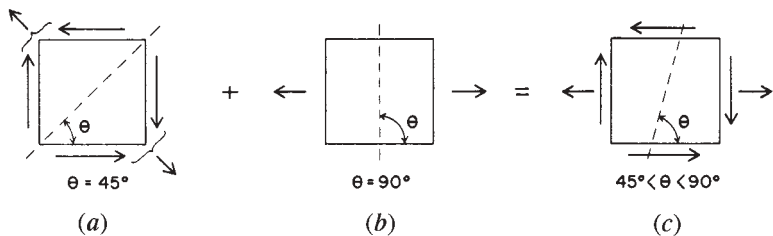
**13.5 COMBINED DIRECT AND SHEAR STRESSES**

The stress actions shown in Figure 13.8 represent the conditions that occur when an internal force of shear alone is considered. When internal shear occurs simultaneously with other effects, the various resulting stress

conditions must be combined to produce the net stress effect. Figure 13.11 shows the result of combining a shear stress effect with a direct tension stress effect. For shear alone, the critical tension stress plane is at  $45^\circ$ , as shown in Figure 13.11*a*. For tension alone, the critical stress plane is at  $90^\circ$ , as shown in Figure 13.11*b*. For the combined shear plus tension (Figure 13.11*c*), the net unit tension stress will be some magnitude higher than either the shear or direct tension stress, and the plane on which this critical tension stress acts will be somewhere between  $45^\circ$  and  $90^\circ$ .

A common example of the stress condition shown in Figure 13.11 occurs in a beam, in which some combination of internal vertical shear and internal bending moment exists at all points in the beam span. Consider the beam shown in profile in Figure 13.12. At all cross sections, the form of distribution of shear and bending stresses, considered alone, are as shown in Figures 13.12*b* and *c*. Various combinations of shear and direct stress may be visualized in terms of the conditions at the cross section labeled S-S in the figure. With reference to the points on the section labeled 1 through 5, the following may be observed:

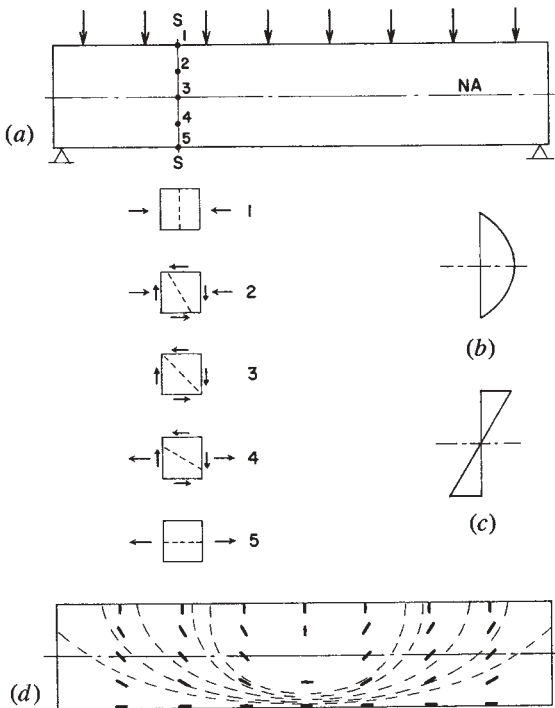
1. At point 1, the vertical shear stress is zero, and the dominant stress is compressive stress due to bending, oriented in a horizontal direction. Tension stress here approaches zero in a vertical direction.
2. At point 5, the vertical shear stress is zero, and the dominant stress is tension stress due to bending, oriented in a horizontal direction.
3. At point 3, the vertical shear stress is maximum, bending stress is zero, and the maximum tension stress is the diagonal stress due to shear, oriented in a  $45^\circ$  direction.



**Figure 13.11** Development of principal net stress due to combined shear and direct stresses.

4. At point 2, the net tension stress acts in a direction between  $45^\circ$  and  $90^\circ$ .
5. At point 4, the net tension stress acts in a direction between  $0^\circ$  and  $45^\circ$ .

The direction of the net tension stress is indicated for various points in the beam by the short dark bars on the beam elevation in Figure 13.12*d*. The light dashed lines indicate the direction of flow of internal tension stress. If Figure 12.12*d* were inverted, it would show the flow of internal compression. This is a highly informative device for visualization of the basic nature of beams.



**Figure 13.12** Direction of development of net tension stresses in a beam.

# 14

---

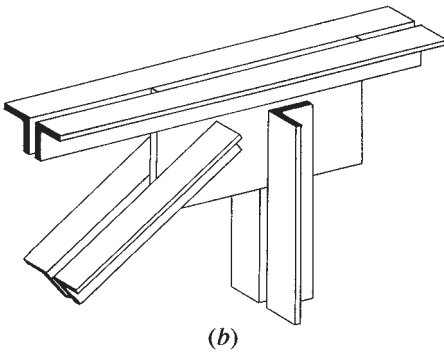
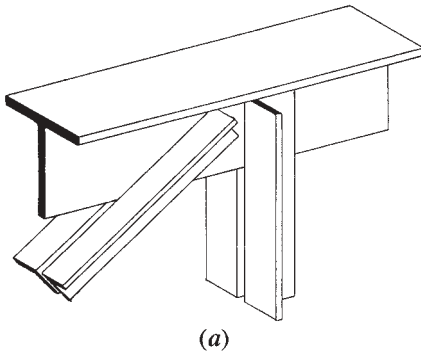
## CONNECTIONS FOR STEEL STRUCTURES

---

Making a steel structure for a building typically involves the connecting of many parts (see Figure 14.1). The technology available for achieving connections is subject to considerable variety, depending on the form and size of the connected parts, the structural forces transmitted between parts, and the nature of the connecting materials. At the scale of building structures, the primary connecting methods utilized presently are those using electric arc welding and high strength steel bolts; these are the methods treated in this chapter.

### 14.1 BOLTED CONNECTIONS

Elements of steel are often connected by mating flat parts with common holes and inserting a pin-type device to hold them together. In times past, the device was a rivet; today, it is usually a bolt. Many types and sizes of bolt are available, as are many connections in which they are used.



**Figure 14.1** At the scale of building structures, the connecting of individual members in a frame system usually involves matching of the flat parts of members. Slipping at the contact face is then prevented by welding or by inserting bolts in matching holes in the members. Contact between members may be direct (a) or through an auxiliary element such as the gusset plate shown in (b).

### Structural Actions of Bolted Connections

Figures 14.2*a* and *b* show plan and section of a simple connection between two steel bars that functions to transfer a tension force from one bar to another. Although this is a tension-transfer connection, it is also referred to as a shear connection because of the manner in which the connecting device (the bolt) works in the connection (see Figure 14.2*c*). For

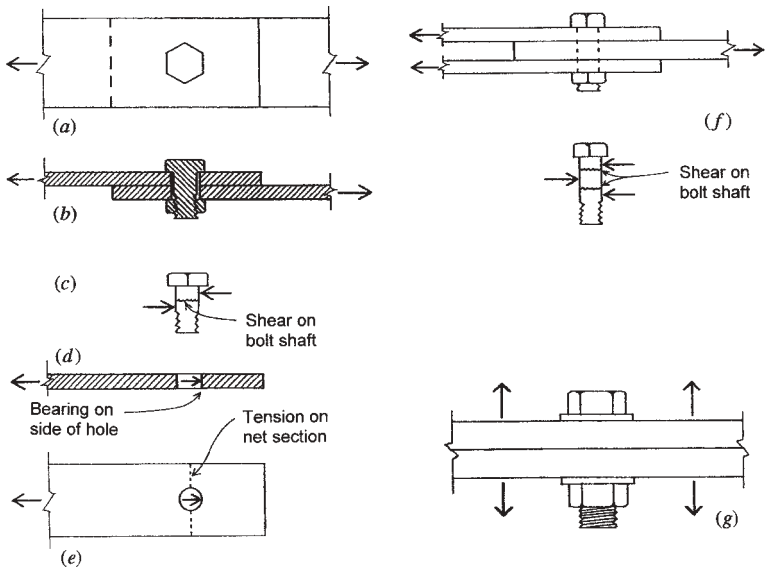


Figure 14.2 Actions of bolted joints.

structural connections, this type of joint is now achieved mostly with so-called *high strength bolts*, which are special bolts that are tightened in a controlled manner that induces development of yield stress in the bolt shaft. For a connection using such bolts, there are many possible forms of failure that must be considered, including the following:

**Bolt Shear.** In the connection shown in Figures 14.2a and b, the failure of the bolt involves a slicing (shear) failure that is developed as a shear stress on the bolt cross section. The resistance of the bolt can be expressed as an allowable shear stress  $F_v$  times the area of the bolt cross section, or

$$R = F_v \times A$$

With the size of the bolt and the grade of steel known, it is a simple matter to establish this limit. In some types of connections, it may be necessary to slice the same bolt more than once to separate the connected parts. This is the case in the connection shown in Figure 14.2f, in which

it may be observed that the bolt must be sliced twice to make the joint fail. When the bolt develops shear on only one section (Figure 14.2c), it is said to be in *single shear*; when it develops shear on two sections (Figure 14.2f), it is said to be in *double shear*.

**Bearing.** If the bolt tension (due to tightening of the nut) is relatively low, the bolt serves primarily as a pin in the matched holes, bearing against the sides of the holes, as shown in Figure 14.2d. When the bolt diameter is larger or the bolt is made of very strong steel, the connected parts must be sufficiently thick if they are to develop the full capacity of the bolt. The maximum bearing stress permitted for this situation by the AISC Specification (see Ref. 3) is  $F_p = 1.5F_u$ , where  $F_u$  is the ultimate tensile strength of the steel in the connected part in which the hole occurs.

**Tension on Net Section of Connected Parts.** For the connected bars in Figure 14.2b, the tension stress in the bars will be a maximum at a section across the bar at the location of the hole. This reduced section is called the *net section* for tension resistance. Although this is indeed a location of critical stress, it is possible to achieve yield here without serious deformation of the connected parts; for this reason, allowable stress at the net section is based on the ultimate—rather than the yield—strength of the bars. The value normally used is  $0.50F_u$ .

**Bolt Tension.** While the shear (slip-resisting) connection shown in Figures 14.2a and b is common, some joints employ bolts for their resistance in tension, as shown in Figure 14.2g. For the threaded bolt, the maximum tension stress is developed at the net section through the cut threads. However, it is also possible for the bolt to have extensive elongation if yield stress develops in the bolt shaft (at an unreduced section). However stress is computed, bolt tension resistance is established on the basis of data from destructive tests.

**Bending in the Connection.** Whenever possible, bolted connections are designed to have a bolt layout that is symmetrical with regard to the directly applied forces. This is not always possible, so that in addition to the direct force actions, the connection may be subjected to twisting due to a bending moment or torsion induced by the loads. Figure 14.3 shows some examples of this situation.

In Figure 14.3a, two bars are connected by bolts, but the bars are not aligned in a way to transmit tension directly between the bars. This may induce a rotational effect on the bolts, with a torsional twist equal to the product of the tension force and the eccentricity due to misalignment of the bars. Shearing forces on individual bolts will be increased by this twisting action. And, of course, the ends of the bars will also be twisted.

Figure 14.3b shows the single-shear joint, as shown in Figure 14.2a and b. When viewed from the top, such a joint may appear to have the bars aligned; however, the side view shows that the basic nature of the single-shear joint is such that a twisting action is inherent in the joint. This twisting increases with thicker bars. It is usually not highly critical for steel structures, where connected elements are usually relatively thin; for connecting of wood elements, however, this is not a favored form of joint.

Figure 14.3c shows a side view of a beam end with a typical form of connection that employs a pair of angles. As shown, the angles grasp the beam web between their legs and turn the other legs out to fit flat against

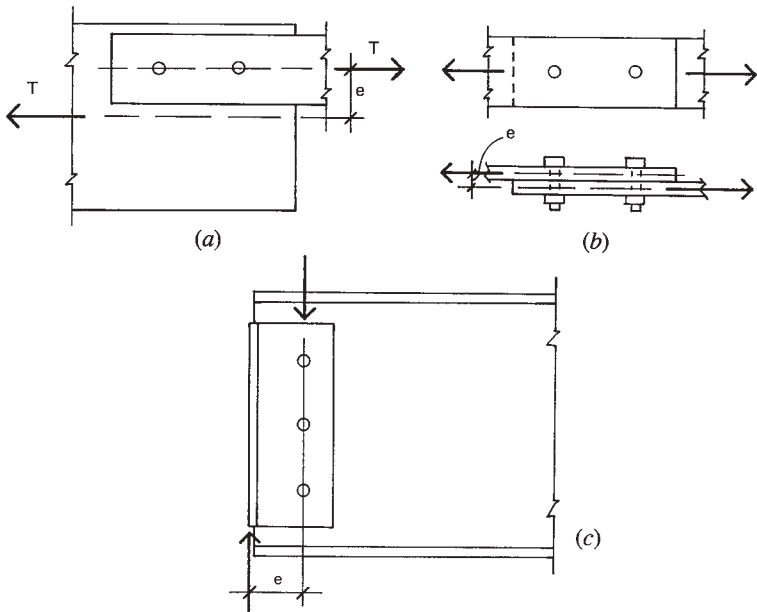


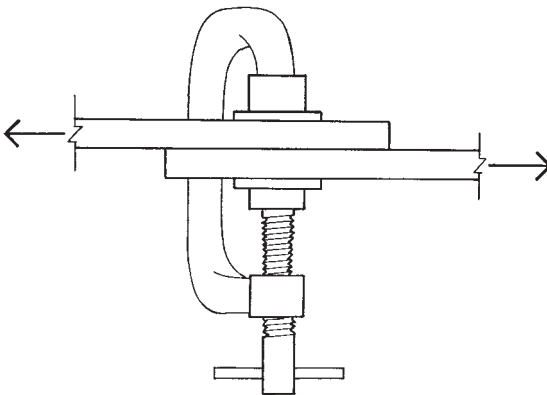
Figure 14.3 Development of bending in bolted joints.



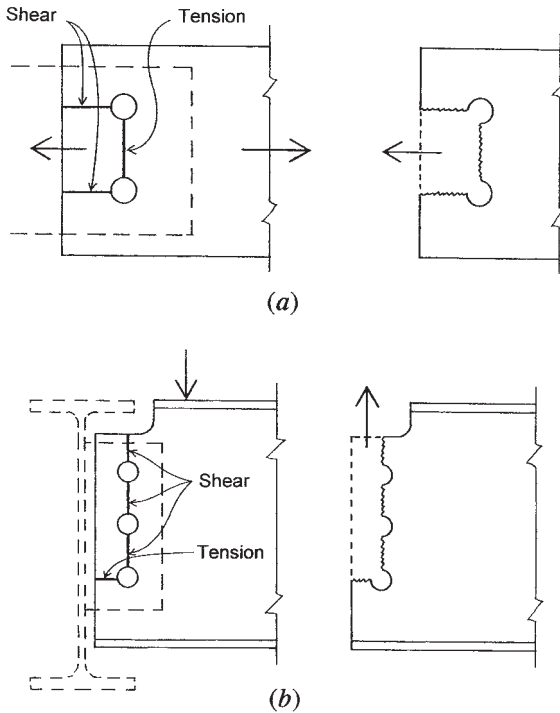
a column or the web of another beam. Vertical load from the beam, vested in the shear in the beam web, is transferred to the angles by the connection of the angles to the beam web—with bolts as shown here. This load is then transferred from the angles at their outward-turned face, resulting in a separated set of forces due to the eccentricity shown. This action must be considered with others in design of these connections.

**Slipping of Connected Parts.** Highly tensioned, high-strength bolts develop a very strong clamping action on the mated flat parts being connected, analogous to the situation shown in Figure 14.4. As a result, there is a strong development of friction at the slip face, which is the initial form of resistance in the shear-type joint. Development of bolt shear, bearing, and even tension on the net section will not occur until this slipping is allowed. For service level loads, therefore, this is the *usual* form of resistance, and the bolted joint with high-strength bolts is considered to be a very rigid form of joint.

**Block Shear.** One possible form of failure in a bolted connection is that of tearing out the edge of one of the attached members. This is called a *block shear* failure. The diagrams in Figure 14.5a show this potentiality in a connection between two plates. The failure in this case involves a combination of shear and tension to produce the torn-out form shown. The total tearing force is computed as the sum required to cause both



**Figure 14.4** Clamping action of highly tightened bolts.



**Figure 14.5** Tearing (block shear) failure in bolted joints.

forms of failure. The allowable stress on the net tension area is specified as  $0.50F_u$ , where  $F_u$  is the maximum tensile strength of the steel. The allowable stress on the shear areas is specified as  $0.30F_u$ . With the edge distance, hole spacing, and diameter of the holes known, the net widths for tension and shear are determined and multiplied by the thickness of the part in which the tearing occurs. These areas are then multiplied by the appropriate stress to find the total tearing force that can be resisted. If this force is greater than the connection design load, the tearing problem is not critical.

Another case of potential tearing is shown in Figure 14.5*b*. This is the common situation for the end framing of a beam in which support is provided by another beam, whose top is aligned with that of the supported beam. The end portion of the top flange of the supported beam must be

cut back to allow the beam web to extend to the side of the supporting beam. With the use of a bolted connection, the tearing condition shown may develop.

## Types of Steel Bolts

Bolts used for the connection of structural steel members come in two basic types. Bolts designated A307 and called *unfinished* have the lowest load capacity of the structural bolts. The nuts for these bolts are tightened just enough to secure a snug fit of the attached parts; because of this low resistance to slipping, plus the over-sizing of the holes to achieve practical assemblage, there is some movement in the development of full resistance. These bolts are generally not used for major connections, especially when joint movement or loosening under vibration or repeated loading may be a problem. They are, however, used extensively for temporary connections during erection of frames.

Bolts designated A325 or A490 are called *high-strength bolts*. The nuts of these bolts are tightened to produce a considerable tension force, which results in a high degree of friction resistance between the attached parts. Different specifications for installation of these bolts results in different classifications of their strength, relating generally to the critical mode of failure.

When loaded in shear-type connections, bolt capacities are based on the development of shearing action in the connection. The shear capacity of a single bolt is further designated as *S* for single shear (Figure 14.2c) or *D* for double shear (Figure 14.2f). The capacities of structural bolts in both tension and shear are given in Table 14.1. These bolts range in size from  $\frac{5}{8}$  to  $1\frac{1}{2}$  in. in diameter, and capacities for these sizes are given in tables in the AISC Manual (Ref. 3). However, the most commonly used sizes for light structural steel framing are  $\frac{3}{4}$  and  $\frac{7}{8}$  in. However, for larger connections and large frameworks, sizes of 1 to  $1\frac{1}{4}$  are also used. This is the size range for which data are given in Table 14.1:  $\frac{3}{4}$  to  $1\frac{1}{4}$ .

Bolts are ordinarily installed with a washer under both head and nut. Some manufactured high-strength bolts have specially formed heads or nuts that in effect have self-forming washers, eliminating the need for a separate, loose washer. When a washer is used, it is sometimes the limiting dimensional factor in detailing for bolt placement in tight locations, such as close to the fillet (inside radius) of angles or other rolled shapes.

**TABLE 14.1 Capacity of Structural Bolts (kips)<sup>a</sup>**

ASTM Designation	Loading Condition <sup>b</sup>	Nominal Diameter of Bolt (in.)				
		$\frac{3}{4}$	$\frac{7}{8}$	1	$1\frac{1}{8}$	$1\frac{1}{4}$
		Area, Based on Nominal Diameter (in. <sup>2</sup> )				
		0.4418	0.6013	0.7854	0.9940	1.227
A307	<i>S</i>	4.4	6.0	7.9	9.9	12.3
	<i>D</i>	8.8	12.0	15.7	19.9	24.5
	<i>T</i>	8.8	12.0	15.7	19.9	24.5
A325	<i>S</i>	7.5	10.2	13.4	16.9	20.9
	<i>D</i>	15.0	20.4	26.7	33.8	41.7
	<i>T</i>	19.4	26.5	34.6	43.7	54.0
A490	<i>S</i>	9.3	12.6	16.5	20.9	25.8
	<i>D</i>	18.6	25.3	33.0	41.7	51.5
	<i>T</i>	23.9	32.5	42.4	53.7	66.3

Source: Adapted from data in the *Manual of Steel Construction*, 8th edition, with permission of the publishers, American Institute of Steel Construction, Chicago, IL.

<sup>a</sup>Slip-critical connections; assuming there is no bending in the connection and that bearing on connected materials is not critical.

<sup>b</sup>*S* = single shear; *D* = double shear; *T* = tension.

For a given diameter of bolt, there is a minimum thickness required for the bolted parts in order to develop the full shear capacity of the bolt. This thickness is based on the bearing stress between the bolt and the side of the hole, which is limited to a maximum of  $F_p = 1.5F_u$ . The stress limit may be established by either the bolt steel or the steel of the bolted parts.

Steel rods are sometimes threaded for use as anchor bolts or tie rods. When they are loaded in tension, their capacities are usually limited by the stress on the reduced section at the threads. Tie rods are sometimes made with *upset ends*, which consist of larger diameter portions at the ends. When these enlarged ends are threaded, the net section at the thread is the same as the gross section in the remainder of the rods; the result is no loss of capacity for the rod.

## Layout of Bolted Connections

Design of bolted connections generally involves a number of considerations in the dimensional layout of the bolt-hole patterns for the attached

structural members. The material in this section presents some basic factors that often must be included in the design of bolted connections. In some situations, the ease or difficulty of achieving a connection may affect the choice for the form of the connected members.

Figure 14.6a shows the layout of a bolt pattern with bolts placed in two parallel rows. Two basic dimensions for this layout are limited by the size (nominal diameter) of the bolt. The first is the center-to-center spacing of the bolts, usually called the *pitch*. The AISC Specification (see Ref. 3) limits this dimension to an absolute minimum of  $2\frac{2}{3}$  times the bolt diameter. The preferred minimum, however, which is used in this book, is 3 times the diameter.

The second critical layout dimension is the *edge distance*, which is the distance from the center line of the bolt to the nearest edge of the member containing the bolt hole. There is also a specified limit for this as a

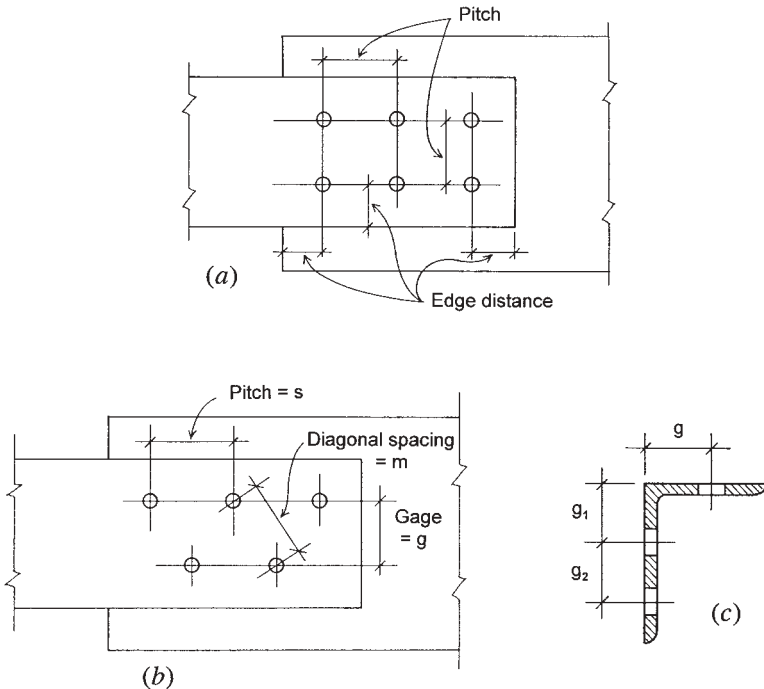


Figure 14.6 Layout considerations for bolted joints.

**TABLE 14.2 Pitch and Edge Distances for Bolts**

Rivet or Bolt Diameter, $d$ (in.)	Minimum Edge Distance for Punched, Reamed, or Drilled Holes (in.)		Minimum Recommended Pitch, Center-to-Center (in.)	
	At Sheared Edges	At Rolled Edges of Plates, Shapes, or Bars, or Gas- Cut Edges <sup>a</sup>	$2.667d$	$3d$
0.625	1.125	0.875	1.67	1.875
0.750	1.25	1.0	2.0	2.25
0.875	1.5 <sup>b</sup>	1.125	2.33	2.625
1.000	1.75 <sup>b</sup>	1.25	2.67	3.0

Source: Adapted from data in the *Manual of Steel Construction*, 8th edition, with permission of the publishers, American Institute of Steel Construction, Chicago, IL.

<sup>a</sup>May be reduced to 0.125 in. when the hole is at a point where stress does not exceed 25% of the maximum allowed in the connected element.

<sup>b</sup>May be 1.25 in. at the ends of beam connection angles.

function of bolt size and the nature of the edge, the latter referring to whether the edge is formed by rolling or is cut. Edge distance may also be limited by edge tearing in block shear, which is discussed later.

Table 14.2 gives the recommended limits for pitch and edge distance for the bolt sizes used in ordinary steel construction.

In some cases, bolts are staggered in parallel rows (Figure 14.6*b*). In this case, the diagonal distance, labeled  $m$  in the illustration, must also be considered. For staggered bolts, the spacing in the direction of the rows is usually referred to as the pitch; the spacing of the rows is called the *gage*. The usual reason for staggering the bolts is that sometimes the rows must be spaced closer (gage spacing) than the minimum spacing required for the bolts selected. However, staggering the bolt holes also helps to create a slightly less critical net section for tension stress in the steel member with the holes.

Location of bolt lines is often related to the size and type of structural members being attached. This is especially true of bolts placed in the legs of angles or in the flanges of W-, M-, S-, C-, and structural tee shapes. Figure 14.6*c* shows the placement of bolts in the legs of angles. When a single row is placed in a leg, its recommended location is at the distance labeled  $g$  from the back of the angle. When two rows are used, the first row is placed at the distance  $g_1$ , and the second row is spaced a distance

**TABLE 14.3 Usual Gage Dimensions for Angles (in.)**

Gage Dimension	Width of Angle Leg (in.)								
	8	7	6	5	4	3.5	3	2.5	2
$g$	4.5	4.0	3.5	3.0	2.5	2.0	1.75	1.375	1.125
$g_1$	3.0	2.5	2.25	2.0					
$g_2$	3.0	3.0	2.5	1.75					

Source: Adapted from data in the *Manual of Steel Construction*, 8th edition, with permission of the publishers, American Institute of Steel Construction, Chicago, IL.

$g_2$  from the first. Table 14.3 gives the recommended values for these distances.

When placed at the recommended locations in rolled shapes, bolts will end up a certain distance from the edge of the part. Based on the recommended edge distance for rolled edges given in Table 14.2, it is thus possible to determine the maximum size of bolt that can be accommodated. For angles, the maximum fastener may be limited by the edge distance, especially when two rows are used; however, other factors may in some cases be more critical. The distance from the center of the bolts to the inside fillet of the angle may limit the use of a large washer where one is required. Another consideration may be the stress on the net section of the angle, especially if the member load is taken entirely by the attached leg.

## Tension Connections

When tension members have reduced cross sections, two stress investigations must be considered. This is the case for members with holes for bolts or for bolts or rods with cut threads. For the member with a hole, the allowable tension stress at the reduced cross section through the hole is  $0.50F_u$ , where  $F_u$  is the ultimate tensile strength of the steel. The total resistance at this reduced section (also called the net section) must be compared with the resistance at other, unreduced sections at which the allowable stress is  $0.60F_y$ .

For threaded steel rods, the maximum allowable tension stress at the threads is  $0.33F_u$ . For steel bolts, the allowable stress is specified as a value based on the type of bolt. The tension load capacities of three types of bolt for various sizes are given in Table 14.1.

For W-, M-, S-, C-, and tee shapes, the tension connection is usually not made in a manner that results in the attachment of all the parts of the section (e.g., both flanges plus the web for a W). In such cases, the AISC Specification (see Ref. 3) requires the determination of a reduced effective net area  $A_e$  that consists of

$$A_e = C_1 A_n$$

in which

$A_n$  = actual net area of the member

$C_1$  = reduction coefficient

Unless a larger coefficient can be justified by tests, the following values are specified:

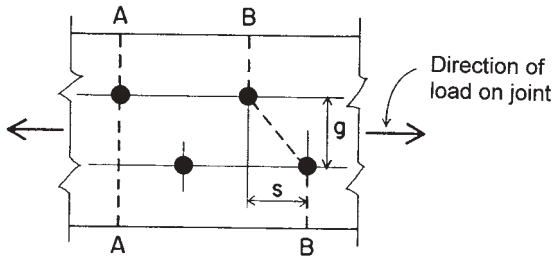
1. For W-, M-, or S-shapes with flange widths not less than two-thirds the depth and structural tees cut from such shapes, when the connection is to the flanges and has at least three fasteners per line in the direction of stress,  $C_1 = 0.75$ .
2. For W-, M-, or S-shapes not meeting the above conditions and for tees cut from such shapes, provided the connection has not fewer than three fasteners per line in the direction of stress,  $C_1 = 0.85$ .
3. For all members with connections that have only two fasteners per line in the direction of stress,  $C_1 = 0.75$ .

Angles used as tension members are often connected by only one leg. In a conservative design, the effective net area is only that of the connected leg, less the reduction caused by bolt holes.

Rivet and bolt holes are punched larger in diameter than the nominal diameter of the fastener. The punching damages a small amount of the steel around the perimeter of the hole; consequently, the diameter of the hole to be deducted in determining the net section is  $\frac{1}{8}$  in. greater than the nominal diameter of the fastener.

When only one hole is involved, as in Figure 14.2, or in a similar connection with a single row of fasteners along the line of stress, the net area of the cross section of one of the plates is found by multiplying the plate thickness by its net width (width of member minus diameter of hole).





**Figure 14.7** Determination of net cross-sectional area for a member in a bolted joint.

When holes are staggered in two rows along the line of stress (Figure 14.7), the net section is determined somewhat differently. The AISC Specification (see Ref. 3) reads:

In the case of a chain of holes extending across a part in any diagonal or zigzag line, the net width of the part shall be obtained by deducting from the gross width the sum of the diameters of all the holes in the chain and adding, for each gage space in the chain, the quantity  $s^2/4g$ , where

- $s$  = longitudinal spacing (pitch) in inches or any two successive holes.
- $g$  = transverse spacing (gage) in inches for the same two holes.

The critical net section of the part is obtained from that chain that gives the least net width.

The AISC Specification also provides that in no case shall the net section through a hole be considered as more than 85% of the corresponding gross section.

## 14.2 DESIGN OF A BOLTED CONNECTION

The issues raised in the preceding sections are illustrated in the following design example.

**Example 1.** The connection shown in Figure 14.8 consists of a pair of narrow plates that transfer a tension force of 100 kips [445 kN] to a single 10-in.-wide [250-mm] plate. All plates are of A36 steel with  $F_y = 36$  ksi [250 MPa] and  $F_u = 58$  ksi [400 MPa] and are attached with  $3/4$ -in.

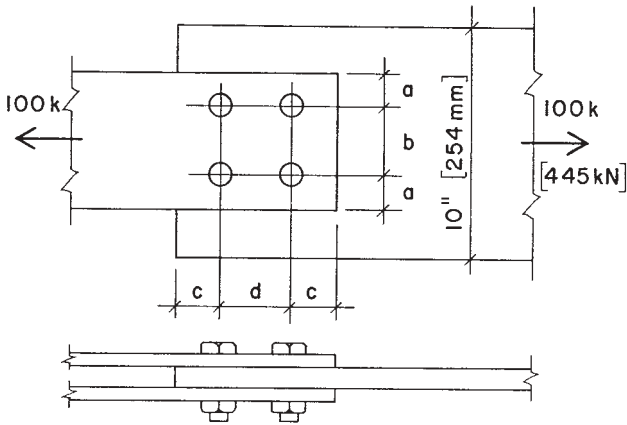


Figure 14.8 Example 1: General considerations.

A325 bolts placed in two rows. Using data from Table 14.1, determine the number of bolts required, the width and thickness of the narrow plates, the thickness of the wide plate, and the layout for the connection.

*Solution:* From Table 14.1, the capacity of a single bolt in double shear is found as 15.5 kips [69 kN]. The required number for the connection is thus

$$n = \frac{100}{15.5} = 6.45, \quad \text{say } 7$$

Although placement of seven bolts in the connection is possible, most designers would choose to have a symmetrical arrangement with eight bolts, four to a row. The average bolt load is thus

$$P = \frac{100}{8} = 12.5 \text{ kips [55.6 kN]}$$

From Table 14.2, for the  $\frac{3}{4}$ -in. bolts, minimum edge distance for a cut edge is 1.25 in. and minimum recommended spacing is 2.25 in. The minimum required width for the plates is thus (see Figure 14.6)

$$w = b + 2(a) = 2.25 + 2(1.25) = 4.75 \text{ in. [121 mm]}$$

If space is tightly constrained, this actual width could be specified for the narrow plates. For this example, a width of 6 in. is used. Checking for

the requirement of stress on the gross area of the plate cross section, where the allowable stress is  $0.60F_y = 0.60(36) = 21.6$  ksi, the required area is

$$A = \frac{100}{21.6} = 4.63 \text{ in.}^2 [2987 \text{ mm}^2]$$

and, with the 6-in. width, the required thickness is

$$t = \frac{4.63}{2 \times 6} = 0.386 \text{ in. [9.8 mm]}$$

This permits the use of a minimum thickness of  $\frac{7}{16}$  in. (0.4375 in.) [11 mm].

The next step is to check the stress on the net section, where the allowable stress is  $0.50F_u = 0.50(58) = 29$  ksi [200 MPa]. For the computations, it is recommended to use a bolt-hole size at least  $\frac{1}{8}$ -in. larger than the bolt diameter. This allows for the true over-size (usually  $\frac{1}{16}$ -in.) and some loss due to the roughness of the hole edges. Thus, the hole is assumed to be  $\frac{7}{8}$ -in. (0.875) in diameter, and the net width is

$$w = 6 - 2(0.875) = 4.25 \text{ in. [108 mm]}$$

and the stress on the net section is

$$f_t = \frac{100}{2(0.4375 \times 4.25)} = 26.9 \text{ ksi [185 MPa]}$$

As this is lower than the allowable stress, the narrow plates are adequate for tension stress.

The bolt capacities in Table 14.1 are based on a slip-critical condition, which assumes a design failure limit to be that of the friction resistance (slip resistance) of the bolts. However, the back-up failure mode is the one in which the plates slip to permit development of the pin-action of the bolts against the sides of the holes; this then involves the shear capacity of the bolts and the bearing resistance of the plates. Bolt shear capacities are higher than the slip failures, so the only concern for this is the bearing on the plates. For this, the AISC Specification (see Ref. 3) allows a value of  $F_p = 1.2F_u = 1.2(58) = 69.6$  ksi [480 MPa].

Bearing stress is computed by dividing the load for a single bolt by the product of the bolt diameter and the plate thickness. Thus, for the narrow plates,

$$f_p = \frac{12.5}{2 \times 0.75 \times 0.4375} = 19.05 \text{ ksi [131 MPa]}$$

which is clearly not a critical concern.

For the middle plate, the procedure is essentially the same, except that the width is given and there is a single plate. As before, the stress on the unreduced cross section requires an area of 4.63 in.<sup>2</sup>, so the required thickness of the 10-in.-wide plate is

$$t = \frac{4.63}{10} = 0.463 \text{ in. [11.8 mm]}$$

which indicates the use of a 1/2-in. thickness.

For the middle plate, the width at the net section is

$$w = 10 - (2 \times 0.875) = 8.25 \text{ in. [210 mm]}$$

and the stress on the net section is

$$f_t = \frac{100}{8.25 \times 0.5} = 24.24 \text{ ksi [167 MPa]}$$

which compares favorably with the allowable of 29 ksi, as determined previously.

The computed bearing stress on the sides of the holes in the middle plate is

$$f_p = \frac{12.5}{0.75 \times 0.50} = 33.3 \text{ ksi [230 MPa]}$$

which is less than the allowable value of 69.6 ksi, as determined previously.

In addition to the layout restrictions described in Section 14.1, the AISC Specification (see Ref. 3) requires that the minimum spacing in the direction of the load be

$$\frac{2P}{F_u t} + \frac{D}{2}$$

and that the minimum edge distance in the direction of the load be

$$\frac{2P}{F_u t}$$

in which

$D$  = the diameter of the bolt

$P$  = the force transmitted by one bolt to the connected part

$t$  = the thickness of the connected part

For this example, for the middle plate, the minimum edge distance is thus

$$\frac{2P}{F_u t} = \frac{2 \times 12.5}{58 \times 0.5} = 0.862 \text{ in.}$$

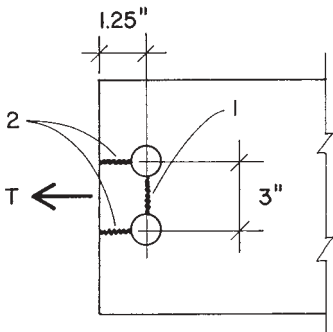
which is considerably less than the distance listed in Table 14.2 for the  $\frac{3}{4}$ -in. bolt at a cut edge: 1.25 in.

For the minimum spacing,

$$\frac{2P}{F_u t} + \frac{D}{2} = 0.862 + 0.375 = 1.237 \text{ in.}$$

which is also not critical.

A final problem that must be considered is the possibility for tearing out of the two bolts at the end of a plate in a block shear failure (Figure 14.9). Because the combined thicknesses of the outer plates is greater than that of the middle plate, the critical case for this connection is that of the middle plate. Figure 14.9 shows the condition for tearing, which



**Figure 14.9** Example 1: Tearing in the middle plate.

involves a combination of tension on the section labeled 1 and shear on the two sections labeled 2. For the tension section,

$$\text{net } w = 3 - 0.875 = 2.125 \text{ in. [54 mm]}$$

and the allowable stress for tension is

$$F_t = 0.50F_u = 29 \text{ ksi [200 MPa]}$$

For the two shear sections,

$$\text{net } w = 2\left(1.25 - \frac{0.875}{2}\right) = 1.625 \text{ in. [41.3 mm]}$$

and the allowable stress for shear is

$$F_v = 0.30F_u = 17.4 \text{ ksi [120 MPa]}$$

The total resistance to tearing is thus

$$T = (2.125 \times 0.5 \times 29) + (1.625 \times 0.5 \times 17.4) = 44.95 \text{ kips [205 kN]}$$

Because this is greater than the combined load on the two end bolts (25 kips), the plate is not critical for tearing in block shear.

The solution for the connection is displayed in the top and side views in Figure 14.10.

Connections that transfer compression between the joined parts are essentially the same with regard to the bolt stresses and bearing on the parts. Stress on the net section in the joined parts is not likely to be critical, since the compression members are likely to be designed for a relatively low stress due to column action.

### ***Problem 14.2.A***

A bolted connection of the general form shown in Fig. 14.8 is to be used to transmit a tension force of 175 kips [780 kN] by using  $\frac{7}{8}$ -in. A325 bolts and plates of A36 steel. The outer plates are to be 8 in. wide [200 mm] and the center plate is to be 12 in. wide [300 mm]. Find the required thicknesses of the plates and the number of bolts needed if the bolts are placed in two rows. Sketch the final layout of the connection.

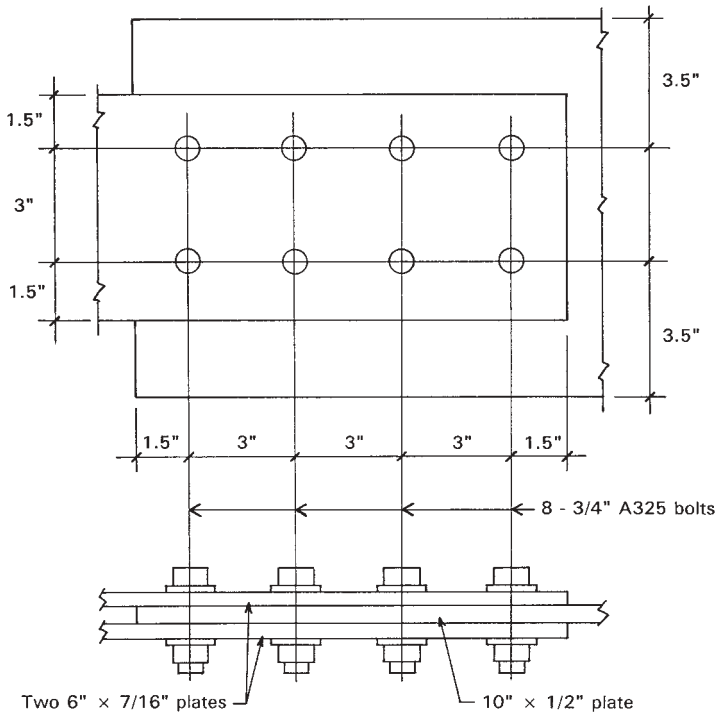


Figure 14.10 Example 1: Layout for the final solution.

**Problem 14.2.B**

Design the connection for the data in Problem 14.2.A, except that the outer plates are 9 in. wide and the bolts are placed in three rows.

**14.3 WELDED CONNECTIONS**

Welding is, in some instances, an alternative means of making connections in a structural joint, the other principal option being structural bolts. A common situation is that of a connecting device (bearing plate, framing angles, etc.) that is welded to one member in the shop and fastened by bolting to a connecting member in the field. However, there are also many instances of joints that are fully welded, whether done in the shop

or at the site of the building construction. For some situations, the use of welding may be the only reasonable means of making an attachment for a joint. As in many other situations, the design of welded joints requires considerable awareness of the problems encountered by the welder and the fabricator of the welded parts.

One advantage of welding is that it offers the possibility for direct connection of members, often eliminating the need for intermediate devices, such as gusset plates or framing angles. Another advantage is the lack of need for holes (required for bolts), which permits development of the capacity of the unreduced cross section of tension members. Welding also offers the possibility of developing exceptionally rigid joints, an advantage in moment-resistive connections or generally nondeforming connections.

### Electric Arc Welding

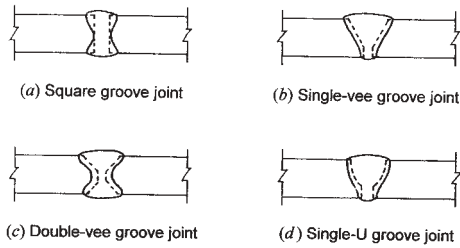
Although there are many welding processes, electric arc welding is the one generally used in steel building construction. In this type of welding, an electric arc is formed between an electrode and the pieces of metal that are to be joined. The term *penetration* is used to indicate the depth from the original surface of the base metal to the point at which fusion ceases. The melted metal from the electrode flows into the molten seat and when cool, unites with the members that are to be welded together. *Partial penetration* is the failure of the weld metal and base metal to fuse at the root of a weld. It may result from a number of items, and such incomplete fusion produces welds that are inferior to those of full penetration (called *complete penetration* welds).

### Types of Welded Connections

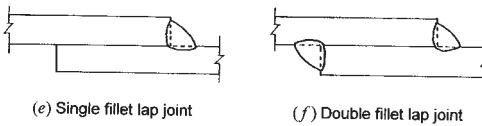
There are three common forms of joints: *butt joints*, *lap joints*, and *tee joints*. Several variations of these joints are shown in Figure 14.11. When two members are to be joined, the ends or edges may or may not be shaped in preparation for welding. The scope of this book prevents a detailed discussion of the many joints and their uses and limitations.

A weld commonly used for structural steel in building construction is the *fillet* weld. It is approximately triangular in cross section and is formed between the two intersecting surfaces of the joined members (see Figures 14.11*e, f*, and *g*). As shown in Figure 14.12*a*, the *size* of a fillet

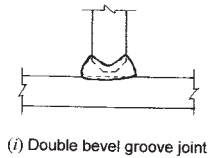
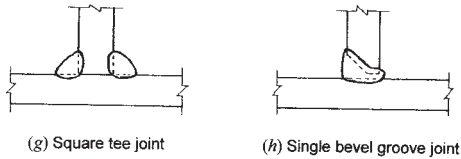




## Butt Joints



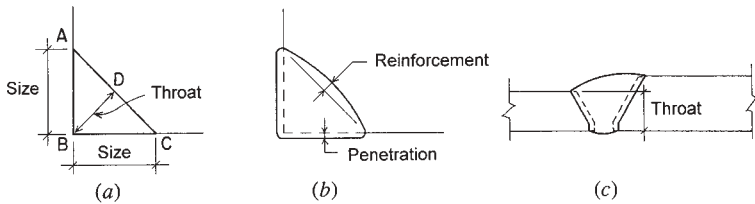
## Lap Joints



## Tee Joints

**Figure 14.11** Common forms for welded joints.

weld is determined by the leg length,  $AB$  or  $BC$ , of the largest isosceles right triangle that can be inscribed within the weld cross section. The *throat* of a fillet weld is the distance from the root to the hypotenuse of this same right triangle, distance  $BD$  in Figure 14.12a. The exposed surface of a weld is not the plane surface indicated in Figure 14.12a, but is



**Figure 14.12** Dimensional considerations for welds.

usually somewhat convex, as shown in Figure 14.12*b*. Therefore, the actual throat may be greater than that shown in Figure 14.12*a*. This additional material is called *reinforcement*. It is not included in the determination of the strength of a weld.

### Stresses in Fillet Welds

If the weld size (dimension  $AB$  in Figure 14.12*a*) is one unit in length, the throat dimension of the weld ( $BD$  in Figure 14.12*a*) is

$$BD = \frac{1}{2}(1^2 + 1^2)^{1/2} = \frac{1}{2}(2)^{1/2} = 0.707$$

Therefore, the throat of a fillet weld is equal to the *size* of the weld multiplied by 0.707. As an example, consider a  $\frac{1}{2}$ -in. fillet weld. This would be a weld with dimensions  $AB$  or  $BC$  equal to  $\frac{1}{2}$  in. In accordance with the above, the throat would be  $0.5 \times 0.707$ , or 0.3535 in. Then, if the allowable unit shearing stress on the throat is 21 ksi, the allowable working strength of a  $\frac{1}{2}$ -in. fillet weld is  $0.3535 \times 21 = 7.42$  kips per lin. in. of weld. If the allowable unit stress is 18 ksi, the allowable working strength is  $0.3535 \times 18 = 6.36$  kips per lin. in. of weld.

The permissible unit stresses used in the preceding paragraph are for welds made with E 70 XX- and E 60 XX-type electrodes on A36 steel. Particular attention is called to the fact that the stress in a fillet weld is considered as shear on the throat, regardless of the direction of the applied load. The allowable working strengths of fillet welds of various sizes are given in Table 14.4 with values rounded to 0.10 kip.

The stresses allowed for the metal of the connected parts (known as the *base metal*) apply to complete penetration groove welds that are stressed in tension or compression parallel to the axis of the weld or are

**TABLE 14.4 Safe Service Loads for Fillet Welds**

Size of Weld (in.)	Allowable Load (kips/in.)		Allowable Load (kN/m)		Size of Weld (mm)
	E 60 XX Electrodes	E 70 XX Electrodes	E 60 XX Electrodes	E 70 XX Electrodes	
3/16	2.4	2.8	0.42	0.49	4.76
1/4	3.2	3.7	0.56	0.65	6.35
5/16	4.0	4.6	0.70	0.81	7.94
3/8	4.8	5.6	0.84	0.98	9.52
1/2	6.4	7.4	1.12	1.30	12.7
5/8	8.0	9.3	1.40	1.63	15.9
3/4	9.5	11.1	1.66	1.94	19.1

stressed in tension perpendicular to the effective throat. They apply also to complete or partial penetration groove welds stressed in compression normal to the effective throat and in shear on the effective throat. Consequently, allowable stresses for butt welds are the same as for the base metal.

The relation between the weld size and the maximum thickness of material in joints connected only by fillet welds is shown in Table 14.5. The maximum size of a fillet weld applied to the square edge of a plate or section that is 1/4 in. or more in thickness should be 1/16 in. less than the nominal thickness of the edge. Along edges of material less than 1/4 in. thick, the maximum size may be equal to the thickness of the material.

The effective area of butt and fillet welds is considered to be the effective length of the weld multiplied by the effective throat thickness. The minimum effective length of a fillet weld should not be less than four

**TABLE 14.5 Relation Between Material Thickness and Size of Fillet Welds**

Material Thickness of the Thicker Part Joined		Minimum Size of Fillet Weld	
in.	mm	in.	mm
To 1/4 inclusive	To 6.35 inclusive	1/8	3.18
Over 1/4 to 1/2	Over 6.35 to 12.7	3/16	4.76
Over 1/2 to 3/4	Over 12.7 to 19.1	1/4	6.35
Over 3/4	Over 19.1	5/16	7.94

times the weld size. For starting and stopping the arc, a distance approximately equal to the weld size should be added to the design length of fillet welds for specification to the welder.

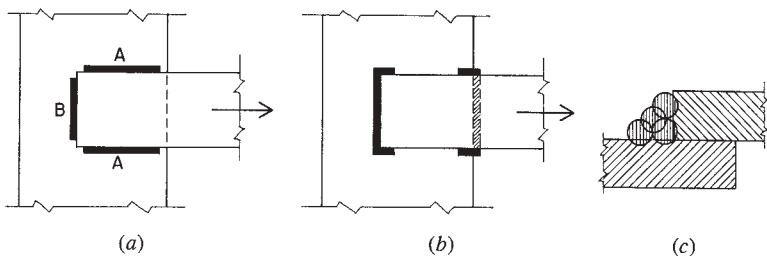
Figure 14.13a represents two plates connected by fillet welds. The welds marked *A* are longitudinal; *B* indicates a transverse weld. If a load is applied in the direction shown by the arrow, the stress distribution in the longitudinal weld is not uniform, and the stress in the transverse weld is approximately 30% higher per unit of length.

Added strength is given to a transverse fillet weld that terminates at the end of a member, as shown in Figure 14.13b, if the weld is returned around the corner for a distance not less than twice the weld size. These end returns, sometimes called *boxing*, afford considerable resistance to the tendency of tearing action on the weld.

The  $\frac{1}{4}$ -in. fillet weld is considered to be the minimum practical size, and a  $\frac{5}{16}$ -in. weld is probably the most economical size that can be obtained by one pass of the electrode. A small continuous weld is generally more economical than a larger discontinuous weld if both are made in one pass. Some specifications limit the single-pass fillet weld to  $\frac{5}{16}$  in. Large fillet welds require two or more passes (multipass welds) of the electrode, as shown in Figure 14.13c.

### Design of Welded Connections

Welding in the shop (factory) is now often achieved by automated processes. However, in the field, welding is almost always achieved by “hand,” and details must be developed on this basis. The following examples demonstrate the design for simple fillet welds for some ordinary connections.



**Figure 14.13** Welding of lapped steel elements with fillet welds.

**Example 2.** A bar of A36 steel,  $3 \times \frac{7}{16}$  in. [ $76.2 \times 11$  mm] in cross section, is to be welded with E 70 XX electrodes to the back of a channel as show in the two views in Figures 14.14*a* and *b*. Determine the size of the fillet weld required to develop the full tensile strength of the bar.

*Solution:* The usual allowable tension stress for this situation is  $0.6F_y$ ; thus,

$$F_a = 0.6(F_y) = 0.6(36) = 21.6 \text{ ksi}$$

and the tension capacity of the bar is thus

$$T = F_a A = 21.6(3 \times 0.4375) = 28.35 \text{ kips}$$

The weld must be of ample size to resist this force.

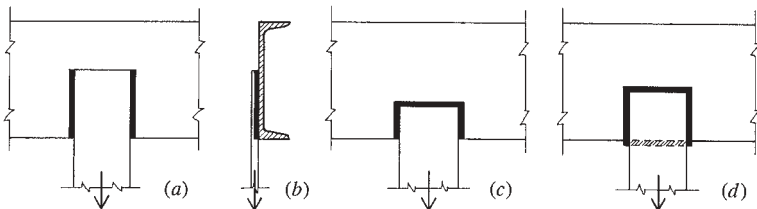
A practical weld size is  $\frac{3}{8}$  in., for which Table 14.4 yields a strength of 5.6 kips/in. The required length to develop the bar strength is thus

$$L = \frac{28.35}{5.6} = 5.06 \text{ in.}$$

Adding a minimum distance equal to the weld size to each end for start and stop of the weld, a practical length for specification would be 6 in.

Figure 14.14 shows three possibilities for the arrangement of the weld. For Figure 14.14*a*, the total weld is divided into two equal parts. As there are now two starts and stops, some additional length should be used. Placing 4 in. of weld on each side of the bar should be adequate.

For the weld in Figure 14.14*c*, there are three parts; the first being a 3-in.-long weld across the end of the bar. That leaves another 3 in. of required weld, which can be split between the two sides of the bar—each being a 2-in. weld to assure a total of 3 in. of effective weld.



**Figure 14.14** Example 2: Variations of form of the welded joint.

Neither of the welds shown in Figures 14.14*a* or *c* provides good resistance to the twisting action on the unsymmetrical joint. To accommodate this action, most designers would provide some additional weld if either of these options is selected. The better weld is that shown in Figure 14.14*d*, where a weld is provided on the back of the bar, between the bar and the corner of the channel. This weld could be developed as an addition to either of the welds in Figures 14.14*a* or *c*. The weld on the back is primarily only a stabilizing weld, and would not be counted for direct resistance of the required tension force.

As may be seen, there is more than computation involved in developing a welded joint—and some judgements are those of individual designers.

**Example 3.** A  $3\frac{1}{2} \times 3\frac{1}{2} \times \frac{5}{16}$ -in. [ $89 \times 89 \times 8$  mm] angle of A36 steel subjected to a tensile load is to be connected to a plate by fillet welds, using E 70 XX electrodes (see Figure 14.15). What should the dimensions of the welds be to develop the full tensile strength of the angle?

*Solution:* From Table 9.5, the cross-sectional area of the angle is 2.09 in.<sup>2</sup> [1348 mm<sup>2</sup>]. The maximum allowable tension stress is  $0.60F_y = 0.60(36) = 21.6$  ksi [150 MPa]; thus, the tensile capacity of the angle is

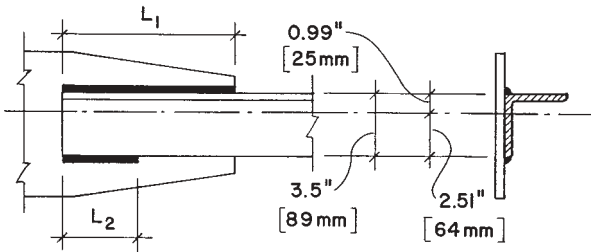
$$T = F_t A = (21.6)(2.09) = 45.1 \text{ kips [200 kN]}$$

For the  $\frac{5}{16}$ -in. angle leg thickness, the maximum recommended weld is  $\frac{1}{4}$  in. From Table 14.4, the weld capacity is 3.7 kips/in. The total length of weld required is thus

$$L = \frac{45.1}{3.7} = 12.2 \text{ in. [310 mm]}$$

This total length could be divided between the two sides of the angle. However, assuming the tension load in the angle to coincide with its centroid, the distribution of the load to the two sides is not in equal shares. Thus, some designers prefer to proportion the lengths of the two welds so that they correspond to their positions on the angle. If this is desired, the following procedure may be used.

From Table 9.5, the centroid of the angle is at 0.99 in. from the back of the angle. Referring to the two weld lengths as shown in Figure 14.15,



**Figure 14.15** Example 3: Form of the welded joint.

their lengths should be in inverse proportion to their distances from the centroid. Thus,

$$L_1 = \left( \frac{2.51}{3.5} \right) (12.2) = 8.75 \text{ in. [222 mm]}$$

and

$$L_2 = \left( \frac{0.99}{3.5} \right) (12.2) = 3.45 \text{ in. [88 mm]}$$

These are the design lengths required, and as noted earlier, each should be made at least  $\frac{1}{4}$  in. longer at each end. Reasonable specified lengths are thus:  $L_1 = 9.25$  in.,  $L_2 = 4.0$  in.

When angle shapes are used as tension members, and are connected at their ends by fastening only one leg, it is questionable to assume a stress distribution of equal magnitude on the entire angle cross section. Some designers therefore prefer to ignore the development of stress in the unconnected leg and to limit the member capacity to the force obtained by considering only the connected leg. If this is done in this example, the maximum tension is thus reduced to

$$T = F_t A = (21.6)(3.5 \times 0.3125) = 23.625 \text{ kips [105 kN]}$$

and the required total weld length is

$$L = \frac{23.625}{3.7} = 6.39 \text{ in. [162 mm]}$$

This length would then be divided evenly between the two sides. Adding an extra length of twice the weld size, a specified length would be for 3.75 in. on each side.

***Problem 14.3.A***

A  $4 \times 4 \times \frac{1}{2}$ -in. angle of A36 steel is to be welded to a plate with E 70 XX electrodes to develop the full tensile strength of the angle. Using  $\frac{3}{8}$ -in. fillet welds, compute the design lengths for the welds on the two sides of the angle, assuming development of tension on the full cross section of the angle.

***Problem 14.3.B***

Same as Problem 14.3.A, except the angle is a  $3 \times 3 \times \frac{3}{8}$ , welds are made with E 60 XX electrodes, and are  $\frac{5}{16}$ -in. fillet welds.

***Problem 14.3.C***

Redesign the welded connection in Problem 14.3.A assuming that the tension force is developed only in the connected leg of the angle.

***Problem 14.3.D***

Redesign the welded connection in Problem 14.3.B assuming that the tension force is developed only in the connected leg of the angle.



# 15

---

## REINFORCED CONCRETE BEAMS

---

This chapter deals primarily with concrete formed with the common binding agent of *Portland cement*, and a loose mass consisting of sand and gravel. With minor variations, this is the material most used for structural concrete—to produce building structures, pavements, and foundations.

### 15.1 GENERAL CONSIDERATIONS

Concrete made from natural materials was used by ancient builders thousands of years ago. Modern concrete, made with industrially produced cement, was developed in the early part of the nineteenth century when the process for producing Portland cement was developed. Because of its lack of tensile strength, however, concrete was used principally for crude, massive structures—foundations, bridge piers, and heavy walls.

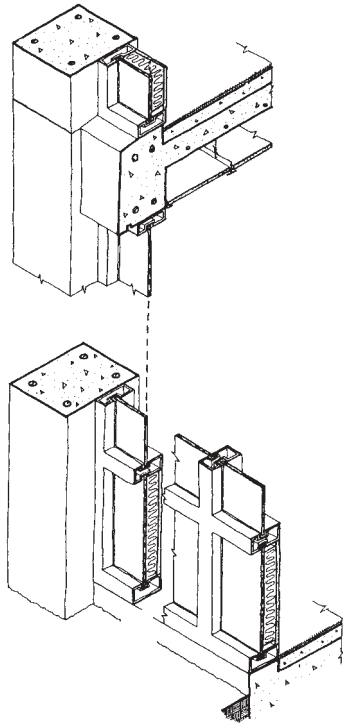
In the mid to late nineteenth century, several builders experimented with the technique of inserting iron or steel rods into relatively thin structures of concrete to enhance their ability to resist tensile forces. This was

the beginning of what we now know as *reinforced concrete* (see Figure 15.1).

For building structures, concrete is mostly used with a method called *sitecast concrete*, in which the wet concrete mix is deposited in some forming at the location where it is to be used. This method is also described as *cast-in-place* or *in situ* construction.

## Design Methods

Traditional structural design was developed primarily with a method now referred to as *stress design*. This method utilizes basic relationships derived from classic theories of elastic behavior of materials. The adequacy



**Figure 15.1** Elements of a concrete frame structure for a building. Most reinforced concrete beams occur in this situation, interacting with simultaneously cast columns and spanning slabs to form a whole concrete system.

or safety of designs is measured by comparison with two primary limits: an acceptable level for maximum stress and a tolerable limit for the extent of deformation (deflection, stretch, etc.). These limits are calculated as they occur in response to the *service loads*, that is, the loads caused by the normal usage conditions visualized for the structure. This method is also called the *working stress method*. The stress limits are called *allowable working stresses*, and the tolerable movements are called *allowable deflection*, *allowable elongation*, and so on.

### The Stress Method

The stress method generally consists of the following.

1. The service (working) load conditions are visualized and quantified as intelligently as possible. Adjustments may be made here by the determination of various statistically likely load combinations (dead load plus live load plus wind load?, etc.), by consideration of load duration, and so on.
2. Stress, stability, and deformation limits are set by standards for the various responses of the structure to the loads: in tension, bending, shear, buckling, deflection, and so on.
3. The structure is then evaluated (investigated) for its adequacy or is proposed (designed) for an adequate response.

An advantage obtained in working with the stress method is that the real usage condition (or at least an intelligent guess about it) is kept continuously in mind. The principal disadvantage comes from its detached nature regarding real failure conditions, since most structures develop much different forms of stress and strain as they approach their failure limits.

### The Strength Method

In essence, the working stress method consists of designing a structure to *work* at some established appropriate percentage of its total capacity. The strength method consists of designing a structure to *fail*, but at a load condition well beyond what it should have to experience in use. A major reason for favoring of strength methods is that the failure of a structure is relatively easily demonstrated by physical testing. What is

truly appropriate as a working condition, however, is pretty much a theoretical speculation. The strength method is now largely preferred in professional design work. It was first largely developed for design of concrete structures, but is now generally taking over all areas of structural design.

Nevertheless, it is considered necessary to study the classic theories of elastic behavior as a basis for visualization of the general ways that structures work. Ultimate responses are usually some form of variant from the classic responses (because of inelastic materials, secondary effects, multimode responses, etc.). In other words, the usual study procedure is to first consider a classic, elastic response, and then to observe (or speculate about) what happens as failure limits are approached.

For the strength method, the process is as follows.

1. The service loads are quantified as in step 1 of the stress method and then are multiplied by an adjustment factor (essentially a safety factor) to produce the *factored load*.
2. The form of response of the structure is visualized and its ultimate (maximum, failure) resistance is quantified in appropriate terms (resistance to compression, to buckling, to bending, etc.). Sometimes this quantified resistance is also subject to an adjustment factor called the *resistance factor*.
3. The usable resistance of the structure is then compared to the ultimate resistance required (an investigation procedure), or a structure with an appropriate resistance is proposed (a design procedure).

When the design process using the strength method employs both load and resistance factors, it is now sometimes called *load and resistance factor design* (abbreviated LRFD).

## Strength of Concrete

The property of concrete of greatest significance for structural purposes is its resistance to compressive stress. As such, the common practice is to specify a desired limiting capacity of compressive stress, to design a concrete mix to achieve that limit, and to test samples of cast and hardened concrete to verify its true capacity for compression. This stress is given the symbol  $f'_c$ .

For design work, the capacity of concrete for all purposes is established as some percentage off  $f'_c$ . Attainment of a quality of concrete to achieve a particular level of compressive resistance generally also serves to certify various other properties, such as hardness, density, and durability. Choice for the desired strength is typically based on the form of construction. For most purposes, a strength of 3000 to 5000 psi for  $f'_c$  is usually adequate. However, strengths of 20,000 psi and higher have recently been achieved for lower columns in very tall structures.

### Stiffness of Concrete

As with other materials, the stiffness of concrete is measured by the *modulus of elasticity*, designated  $E$ . This modulus is established by tests and is the ratio of stress to strain. Since strain has no unit designation (measured as inch/inch, etc.), the unit for  $E$  thus becomes the unit for stress, usually psi or ksi [MPa].

The magnitude of elasticity for concrete,  $E_c$ , depends on the weight of the concrete and its strength. For values of unit weight between 90 and 155 lb/ft<sup>3</sup> or pcf, the value of  $E_c$  is determined as

$$E_c = w^{1.5} 33 \sqrt{f'_c}$$

The unit weight for ordinary stone-aggregate concrete is usually assumed to be an average of 145 pcf. Substituting this value for  $w$  in the equation results in an average concrete modulus of

$$E_c = 57,000 \sqrt{f'_c}$$

For metric units, with stress measured in megapascals, the expression becomes

$$E_c = 4730 \sqrt{f'_c}$$

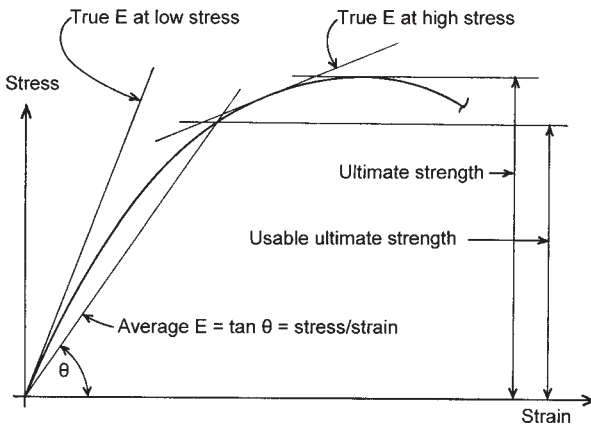
Distribution of stresses and strains in reinforced concrete is dependent on the concrete modulus, the steel modulus being a constant. This is discussed in Section 15.2. In the design of reinforced concrete members, the term  $n$  is employed. This is the ratio of the modulus of elasticity of steel

to that of concrete, or  $n = E_s/E_c$ .  $E_s$  is taken as 29,000 ksi [200,000 MPa], a constant. Values for  $n$  are usually given in tables of properties, although they are typically rounded off.

In truth, the modulus of elasticity of concrete is a variable, not a constant value. The general form of the stress/strain graph for concrete is shown in Figure 15.2. When plotted all the way to the failure of the material, it describes a considerably curved form. Thus, the material has its greatest stiffness at low stress and loses stiffness continuously as it approaches its stress limit. It therefore becomes necessary to decide on the stress range at which a value for stiffness is to be considered. For determination of structural deformations (deflection of beams, etc.) at usage loading well below the ultimate limit, an average value for  $E$  may be taken for the somewhat less curved lower portion of the graph. This is generally the procedure for computation of  $E$  values used for design work.

## Cement

The cement used most extensively in building construction is *Portland cement*. Of the five types of standard Portland cement generally available in the United States and for which the American Society for Testing and



**Figure 15.2** Consideration of the value for modulus of elasticity of concrete.

Materials has established specifications, two types account for most of the cement used in buildings. These are a general-purpose cement for use in concrete designed to reach its required strength in about 28 days, and a high-early-strength cement for use in concrete that attains its design strength in a period of a week or less. All Portland cements set and harden by reacting with water, and this hydration process is accompanied by generation of heat.

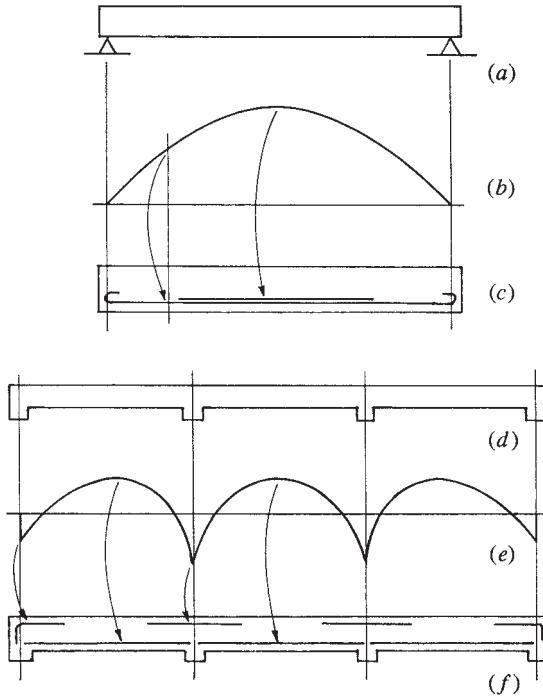
## Reinforcement

The steel used in reinforced concrete consists of round bars, mostly of the deformed type, with lugs or projections on their surfaces. The surface deformations help to develop a greater bond between the steel rods and the enclosing concrete mass.

***Purpose of Reinforcement.*** The essential purpose of steel reinforcing is to reduce the failure of the concrete due to tensile stresses (see Figure 15.3). Structural actions are investigated for the development of tension in the structural members and steel reinforcement in the proper amount is placed within the concrete mass to resist the tension. In some situations, steel reinforcement may also be used to increase compressive resistance, since the ratio of magnitudes of strength of the two materials is quite high; thus, the steel displaces a much weaker material and the member gains significant strength.

Tension stress can be induced by shrinkage of the concrete during its drying out from the initial wet mix. Temperature variations may also induce tension in many situations. To provide for these latter actions, a minimum amount of reinforcing is used in surface-type members such as walls and paving slabs, even when no structural action is visualized.

***Stress-Strain Considerations.*** The most common types of steel used for ordinary reinforcing bars are Grade 40 and Grade 60, having yield strengths of 40 ksi [276 MPa] and 60 ksi [414 MPa], respectively. The yield strength of the steel is of primary interest for two reasons. Plastic yielding of the steel generally represents the limit of its practical utilization for reinforcing of the concrete, since the extensive deformation of the steel in its plastic range results in major cracking of the concrete. Thus, for service load conditions, it is desirable to keep the stress in the steel within its elastic range of behavior where deformation is minimal.



**Figure 15.3** Utilization of reinforcement in concrete beams. (a) Simple beam. (b) Form of the moment diagram for uniformly distributed loading on a simple beam. (c) Use of flexural reinforcement for a simple beam. (d) Continuous beam, typical of concrete construction. (e) Form of the moment diagram for uniformly distributed loading on a continuous beam. (f) Use of flexural reinforcement for a continuous beam.

The second reason for the importance of the yield character of the reinforcing is its ability to impart a generally yielding nature (plastic deformation character) to the otherwise typically very brittle concrete structure. This is of particular importance for dynamic loading, and is a major consideration in design for earthquake forces. Also of importance is the residual strength of the steel beyond its yield stress limit. The steel continues to resist stress in its plastic range and then gains a second, higher, strength before failure. Thus, the failure induced by yielding is only a first stage response, and a second level of resistance is reserved.



**Cover.** Ample concrete protection, called *cover*, must be provided for the steel reinforcement. This is important to protect the steel from rusting and to be sure that it is well engaged by the mass of concrete. Cover is measured as the distance from the outside face of the concrete to the edge of the reinforcing bar.

Code minimum requirements for cover are  $\frac{3}{4}$  in. for walls and slabs and  $1\frac{1}{2}$  in. for beams and columns. Additional distance of cover is required for extra fire protection or for special conditions of exposure of the concrete surface to weather or by contact with the ground.

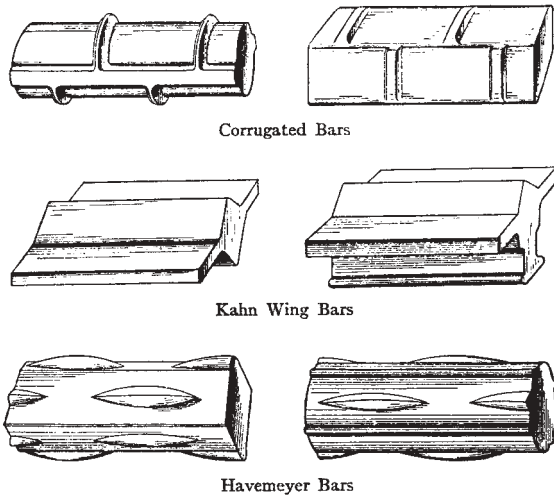
**Spacing of Bars.** Where multiple bars are used in concrete members (which is the common situation), there are both upper and lower limits for the spacing of the bars. Lower limits are intended to facilitate the flow of wet concrete during casting and to permit adequate development of the concrete-to-steel stress transfers for individual bars.

Maximum spacing is generally intended to assure that there is some steel that relates to a concrete mass of limited size; that is, there is not too extensive a mass of concrete with no reinforcement. For relatively thin walls and slabs, there is also a concern of scale of spacing related to the thickness of the concrete.

**Amount of Reinforcement** For structural members, the amount of reinforcement is determined from structural computations as that required for the tension force in the member. This amount (in total cross-sectional area of the steel) is provided by some combination of bars. In various situations, however, there is a minimum amount of reinforcement that is desirable, which may on occasion exceed the amount determined by computation. Minimum reinforcement may be specified as a minimum number of bars or as a minimum amount of steel cross-sectional area, the latter usually based on the amount of the cross-sectional area of the concrete member.

**Standard Reinforcing Bars.** In early concrete work, reinforcing bars took various shapes. An early problem that emerged was the proper bonding of the steel bars within the concrete mass, due to the tendency of the bars to slip or pull out of the concrete.

In order to anchor the bars in the concrete, various methods were used to produce something other than the usual smooth surfaces on bars (see Figure 15.4). After much experimentation and testing, a single set of bars



**Figure 15.4** Forms of early steel reinforcing bars. Reproduced from *Concrete—Plain and Reinforced*, by Frederick W. Taylor and Sanford E. Thompson, 1916, with permission of the publisher, John Wiley & Sons, New York.

was developed with a form similar to that for the top left bar in Figure 15.4. Deformed bars were produced in graduated sizes with bars identified by a single number (see Table 15.1).

For bars numbered 2 through 8, the cross-sectional area is equivalent to a round bar having a diameter of as many eighths of an inch as the bar number. Thus, a No. 4 bar is equivalent to a round bar of  $\frac{4}{8}$  or 0.5 in. diameter. Bars numbered from 9 up lose this identity, and are essentially identified by the tabulated properties in a reference document.

The bars in Table 15.1 are developed in U.S. units, but can, of course, be used with their properties converted to metric units. However, a new set of bars has recently been developed, deriving their properties more logically from metric units. The general range of sizes is similar for both sets of bars, and design work can readily be performed with either set. Metric-based bars are obviously more popular outside the United States, but for domestic use (nongovernment) in the United States, the old bars are still in wide use. This is part of a wider conflict over units that is still going on.

The work in this book uses the old inch-based bars, simply because the computational examples are done in U.S. units. In addition, many widely used references still use U.S. units and the old bar sizes.

**TABLE 15.1 Properties of Deformed Reinforcing Bars**

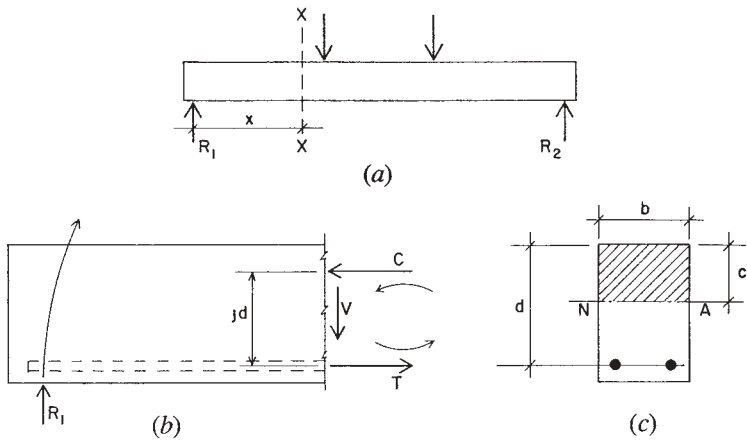
Bar Size Designation	Nominal Dimensions					
	Nominal Weight		Diameter		Cross-Sectional Area	
	lb/ft	kg/m	in.	mm	in. <sup>2</sup>	mm <sup>2</sup>
No. 3	0.376	0.560	0.375	9.5	0.11	71
No. 4	0.668	0.994	0.500	12.7	0.20	129
No. 5	1.043	1.552	0.625	15.9	0.31	200
No. 6	1.502	2.235	0.750	19.1	0.44	284
No. 7	2.044	3.042	0.875	22.2	0.60	387
No. 8	2.670	3.974	1.000	25.4	0.79	510
No. 9	3.400	5.060	1.128	28.7	1.00	645
No. 10	4.303	6.404	1.270	32.3	1.27	819
No. 11	5.313	7.907	1.410	35.8	1.56	1006
No. 14	7.650	11.390	1.693	43.0	2.25	1452
No. 18	13.600	20.240	2.257	57.3	4.00	2581

## 15.2 FLEXURE: STRESS METHOD

For wood or steel beams, the usual concern is only for the singular maximum values of bending and shear in a given beam. For concrete beams, on the other hand, it is necessary to provide for the values of bending and shear as they vary along the entire length of a beam; even through multiple spans in the case of continuous beams, which are a common occurrence in concrete structures. For simplification of the work, it is necessary to consider the actions of a beam at a specific location, but it should be borne in mind that this action must be integrated with all the other effects on the beam throughout its length.

When a member is subjected to bending, such as the beam shown in Figure 15.5*a*, internal resistances of two basic kinds are generally required. Internal actions are “seen” by visualizing a cut section, such as that taken at X-X in Figure 15.5*a*. Removing the portion of the beam to the left of the cut section, its free-body actions are as shown in Figure 15.5*b*. At the cut section, consideration of static equilibrium requires the development of the internal shear force ( $V$  in the figure) and the internal resisting moment (represented by the force couple:  $C$  and  $T$  in the figure).

If a beam consists of a simple rectangular concrete section with tension reinforcement only, as shown in Figure 15.5*c*, the force  $C$  is considered to be developed by compressive stresses in the concrete—indicated

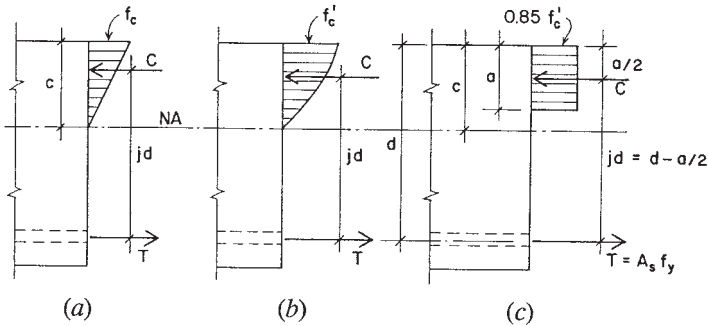


**Figure 15.5** Development of bending in a reinforced concrete beam.

by the shaded area above the neutral axis. The tension force, however, is considered to be developed by the steel alone, ignoring the tensile resistance of the concrete. For low-stress conditions, the latter is not true, but at a serious level of stress, the tension-weak concrete will indeed crack, virtually leaving the steel unassisted, as assumed.

At moderate levels of stress, the resisting moment is visualized as shown in Figure 15.6a, with a linear variation of compressive stress from zero at the neutral axis to a maximum value of  $f'_c$  at the edge of the section. As stress levels increase, however, the nonlinear stress-strain character of the concrete becomes more significant, and it becomes necessary to acknowledge a more realistic form for the compressive stress variation, such as that shown in Figure 15.6b. As stress levels approach the limit of the concrete, the compression becomes vested in an almost constant magnitude of unit stress, concentrated near the top of the section. For strength design, in which the moment capacity is expressed at the ultimate limit, it is common to assume the form of stress distribution shown in Figure 15.6c, with the limit for the concrete stress set at 0.85 times  $f'_c$ . Expressions for the moment capacity derived from this assumed distribution have been shown to compare reasonably with the response of beams tested to failure in laboratory experiments.

Response of the steel reinforcement is more simply visualized and expressed. Since the steel area in tension is concentrated at a small location



**Figure 15.6** Distribution of bending stress in a reinforced concrete beam. (a) At low levels of stress. (b) At the point where the maximum stress in the concrete approaches the limit. (c) As assumed for investigation by the strength method.

with respect to the size of the beam, the stress in the bars is considered to be a constant. Thus, at any level of stress, the total value of the internal tension force may be expressed as

$$T = A_s f_s$$

and for the practical limit of  $T$ ,

$$T = A_s f_y$$

In stress design, a maximum allowable (working) value for the extreme fiber stress is established and the formulas are predicated on elastic behavior of the reinforced concrete member under service load. The straight-line distribution of compressive stress is valid at working stress levels because the stresses developed vary approximately with the distance from the neutral axis, in accordance with elastic theory.

The following is a presentation of the formulas and procedures used in the stress method. The discussion is limited to a rectangular beam section with tension reinforcement only.

Referring to Figure 15.7, the following are defined.

- $b$  = width of the concrete compression zone
- $d$  = effective depth of the section for stress analysis; from the centroid of the steel to the edge of the compressive zone

- $A_s$  = cross-sectional area of reinforcing bars
- $p$  = percentage of reinforcement, defined as  $p = A_s/bd$
- $n$  = elastic ratio, defined as  $n = (E \text{ of the steel})/(E \text{ of the concrete})$
- $kd$  = height of the compression stress zone; used to locate the neutral axis of the stressed section; expressed as a decimal fraction ( $k$ ) of  $d$
- $jd$  = internal moment arm, between the net tension force and the net compression force; expressed as a decimal fraction ( $j$ ) of  $d$
- $f_c$  = maximum compressive stress in the concrete
- $f_s$  = tensile stress in the reinforcement

The compression force  $C$  may be expressed as the volume of the compression stress “wedge,” as shown in the figure:

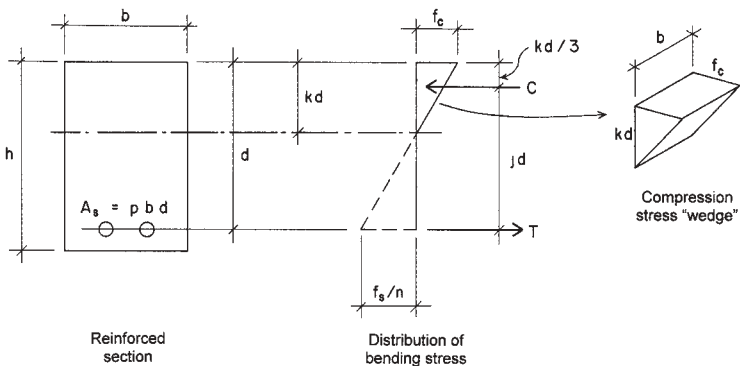
$$C = \frac{1}{2}(kd)(b)(f_c) = \frac{1}{2}kf_cbd$$

Using this force, we may express the moment resistance of the section as

$$M = Cjd = (\frac{1}{2}kf_cbd)(jd) = \frac{1}{2}kjf_cbd^2 \tag{15.2.1}$$

This may be used to derive an expression for the concrete stress:

$$f_c = \frac{2M}{kjb d^2} \tag{15.2.2}$$



**Figure 15.7** Development of bending resistance: stress method.

The resisting moment may also be expressed in terms of the steel and the steel stress as

$$M = Tjd = A_s f_s jd$$

This may be used for determination of the steel stress as

$$f_s = \frac{M}{A_s jd} \quad (15.2.3)$$

or for finding the required area of steel as

$$A_s = \frac{M}{f_s jd} \quad (15.2.4)$$

A useful reference is the so-called *balanced section*, which occurs when use of the exact amount of reinforcement results in the simultaneous development of the limiting stresses in the concrete and steel. The properties that establish this relationship may be expressed as follows:

$$k = \frac{1}{1 + (f_s / m f_c)} \quad (15.2.5)$$

$$j = 1 - \left( \frac{k}{3} \right) \quad (15.2.6)$$

$$p = \frac{f_c k}{2 f_s} \quad (15.2.7)$$

$$M = R b d^2 \quad (15.2.8)$$

in which

$$R = \frac{1}{2} k j f_c \quad (15.2.9)$$

derived from equation (15.2.1).

If the limiting compression stress in the concrete ( $f_c = 0.45 f'_c$ ) and the limiting stress in the steel are entered in equation (15.2.5), the balanced

section value for  $k$  may be found. Then the corresponding values for  $j$ ,  $p$ , and  $R$  may be found. The balanced  $p$  may be used to determine the maximum amount of tensile reinforcement that may be used in a section without the addition of compressive reinforcing. If less tensile reinforcement is used, the moment will be limited by the steel stress, the maximum stress in the concrete will be below the limit of  $0.45f'_c$ , the value of  $k$  will be slightly lower than the balanced value, and the value of  $j$  will be slightly higher than the balanced value. These relationships are useful in design for the determination of approximate requirements for cross sections.

Table 15.2 gives the balanced section properties for various combinations of concrete strength and limiting steel stress. The values of  $n$ ,  $k$ ,  $j$ , and  $p$  are all without units. However,  $R$  must be expressed in particular units; the units in the table are kips per square inch (ksi) and kilopascals (kPa).

When the area of steel used is less than the balanced  $p$ , the true value of  $k$  may be determined by the following formula:

$$k = \sqrt{2np - (np)^2} - np$$

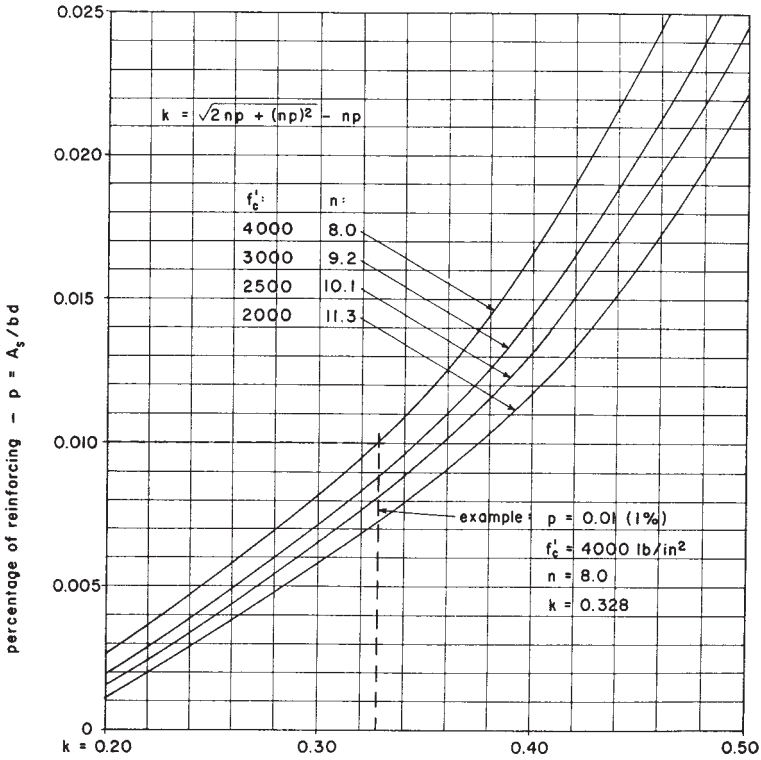
Figure 15.8 may be used to find approximate  $k$  values for various combinations of  $p$  and  $n$ .

Beams with reinforcement less than that required for the balanced moment are called *under-balanced sections* or *under-reinforced sections*. If a beam must carry bending moment in excess of the balanced moment

**TABLE 15.2 Balanced Section Properties for Rectangular Sections with Tension Reinforcement Only**

$f_s$		$f'_c$		$n$	$k$	$j$	$p$	$R$	
ksi	MPa	ksi	MPa					ksi	kPa
20	138	2	13.79	11.3	0.337	0.888	0.0076	0.135	928
		3	20.68	9.2	0.383	0.872	0.0129	0.226	1554
		4	27.58	8.0	0.419	0.860	0.0188	0.324	2228
		5	34.48	7.1	0.444	0.852	0.0250	0.426	2937
24	165	2	13.79	11.3	0.298	0.901	0.0056	0.121	832
		3	20.68	9.2	0.341	0.886	0.0096	0.204	1403
		4	27.58	8.0	0.375	0.875	0.0141	0.295	2028
		5	34.48	7.1	0.400	0.867	0.0188	0.390	2690





**Figure 15.8** Flexural  $k$  factors for rectangular beams with tensile reinforcing only, as a function of  $p$  and  $n$ .

for the section, it is necessary to provide some compressive reinforcement. The balanced section is not necessarily a design ideal, but is useful in establishing the limits for the section.

In the design of concrete beams, there are two situations that commonly occur. The first occurs when the beam is entirely undetermined, that is, when both the concrete dimensions and the reinforcement needed are unknown. The second occurs when the concrete dimensions are given, and the required reinforcement for a specific bending moment must be determined. The following examples illustrate the use of the formulas just developed for each of these problems.

**Example 1.** A rectangular concrete beam with concrete having  $f'_c$  of 3000 psi [20.7 MPa] and steel reinforcement with  $f_s = 20$  ksi [138 MPa] must sustain a bending moment of 200 kip-ft [271 kN-m]. Select the beam dimensions and the reinforcement for a section with tension reinforcement only.

*Solution:* With tension reinforcement only, the minimum size beam is a balanced section, since a smaller beam would have to be stressed beyond the capacity of the concrete to develop the required moment. Using equation (15.2.8),

$$M = Rbd^2 = 200 \text{ kip-ft [271 kN-m]}$$

Then, from Table 15.2, for  $f'_c$  of 3000 psi and  $f_s$  of 20 ksi,

$$R = 0.226 \text{ (in units of kip-in.) [1554 in units of kN-m]}$$

Therefore,

$$M = 200 \times 12 = 0.226(bd^2) \quad \text{and} \quad bd^2 = 10,619$$

Various combinations of  $b$  and  $d$  may be found; for example:

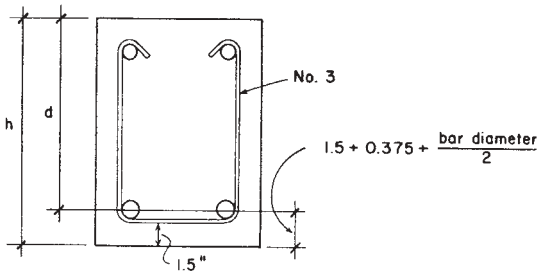
$$\begin{aligned} b = 10 \text{ in.}, \quad d &= \sqrt{\frac{10,619}{10}} = 32.6 \text{ in.} \\ [b = 0.254 \text{ m}, \quad d &= 0.829 \text{ m}] \\ b = 15 \text{ in.}, \quad d &= \sqrt{\frac{10,619}{15}} = 26.6 \text{ in.} \\ [b = 0.381 \text{ m}, \quad d &= 0.677 \text{ m}] \end{aligned}$$

Although they are not given in this example, there are often considerations other than flexural behavior alone that influence the choice of specific dimensions for a beam. These may include:

Design for shear.

Coordination of the depths of a set of beams in a framing system.

Coordination of the beam dimensions and placement of reinforcement in adjacent beam spans.



**Figure 15.9** Common form of reinforcement for a rectangular concrete beam section.

Coordination of beam dimensions with supporting columns.

Limiting beam depth to provide overhead clearance beneath the structure.

If the beam is of the ordinary form shown in Figure 15.9, the specified dimension is usually that given as  $h$ . Assuming the use of a No. 3 U-stirrup, a cover of 1.5 in. [38 mm], and an average-size reinforcing bar of 1-in. [25-mm] diameter (No. 8 bar), the design dimension  $d$  will be less than  $h$  by 2.375 in. [60 mm]. Lacking other considerations, assume a  $b$  of 15 in. [380 mm] and an  $h$  of 29 in. [740 mm], with the resulting  $d$  of  $29 - 2.375 = 26.625$  in. [680 mm].

Next, use the specific value for  $d$  with equation (15.2.4) to find the required area of steel  $A_s$ . Since the selection is very close to the balanced section, use the value of  $j$  from Table 15.2. Thus,

$$A_s = \frac{M}{f_s j d} = \frac{200 \times 12}{(20)(0.872)(26.625)} = 5.17 \text{ in.}^2 [3312 \text{ mm}^2]$$

Or, using the formula for the definition of  $p$  and the balanced  $p$  value from Table 15.2,

$$A_s = p b d = 0.0129(15 \times 26.625) = 5.15 \text{ in.}^2 [3312 \text{ mm}^2]$$

Next, select a set of reinforcing bars to obtain this area. For the purpose of the example, select bars all of a single size (see Table 15.2); the number required will be:

No. 6 bars:  $5.17/0.44 = 11.75$ , or 12 [ $3312/284 = 11.66$ ].

No. 7 bars:  $5.17/0.60 = 8.62$ , or 9 [ $3312/387 = 8.56$ ].

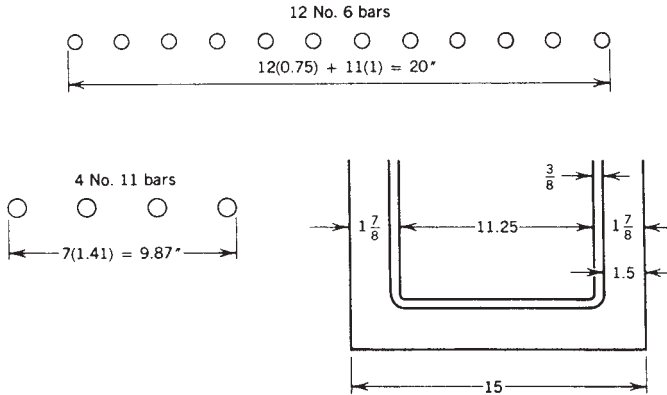
No. 8 bars:  $5.17/0.79 = 6.54$ , or 7 [ $3312/510 = 6.49$ ].

No. 9 bars:  $5.17/1.00 = 5.17$ , or 6 [ $3312/645 = 5.13$ ].

No. 10 bars:  $5.17/1.27 = 4.07$ , or 5 [ $3312/819 = 4.04$ ].

No. 11 bars:  $5.17/1.56 = 3.31$ , or 4 [ $3312/1006 = 3.29$ ].

In real design situations, there are always various additional considerations that influence the choice of the reinforcing bars. One general desire is that of having the bars in a single layer, as this keeps the centroid of the steel as close as possible to the edge (bottom in this case) of the member, giving the greatest value for  $d$  with a given height ( $h$ ) of a concrete section. With the section as shown in Figure 15.9, a beam width of 15 in. will yield a net width of 11.25 in. inside the No. 3 stirrups (outside width of 15 less  $2 \times 1.5$  cover and  $2 \times 0.375$  stirrup diameter). Applying the code criteria for minimum spacing for this situation, the required width for the various bar combinations can be determined. Minimum space required between bars is one bar diameter or a lower limit of one inch. Two examples for this are shown in Figure 15.10. It will be found that the four No. 11 bars are the only choice that will fit this beam width.



**Figure 15.10** Consideration of beam width for proper spacing of reinforcement in a single layer.

**Example 2.** A rectangular beam of concrete with  $f'_c$  of 3000 psi [20.7 MPa] and steel with  $f_s$  of 20 ksi [138 MPa] has dimensions of  $b = 15$  in. [380 mm] and  $h = 36$  in. [910 mm]. Find the area required for the steel reinforcement for a moment of 200 kip-ft [271 kN-m].

*Solution:* The first step in this case is to determine the balanced moment capacity of the beam with the given dimensions. If we assume the section to be as shown in Figure 15.9, we may assume an approximate value for  $d$  to be  $h$  minus 2.5 in. [64 mm], or 33.5 in. [851 mm]. Then, with the value for  $R$  from Table 15.2,

$$M = Rbd^2 = (0.226)(15)(33.5)^2 = 3804 \text{ kip-in.}$$

or

$$M = \frac{3804}{12} = 317 \text{ kip-ft} \quad \left[ M = (1554)(0.380)(0.850)^2 = 427 \text{ kN-M} \right]$$

Since this value is considerably larger than the required moment, it is thus established that the given section is larger than that required for a balanced stress condition. As a result, the concrete flexural stress will be lower than the limit of  $0.45f'_c$ , and the section is qualified as being under-reinforced, which is to say that the reinforcement required will be less than that required to produce a balanced section (with moment capacity of 317 kip-ft). In order to find the required area of steel, we use equation (15.2.4), just as we did in the preceding example. However, the true value for  $j$  in the equation will be something greater than that for the balanced section (0.872 from Table 15.2).

As the amount of reinforcement in the section decreases below the full amount required for a balanced section, the value of  $k$  decreases and the value of  $j$  increases. However, the range for  $j$  is small: from 0.872 up to something less than 1.0. A reasonable procedure is to assume a value for  $j$ , find the corresponding required area, and then perform an investigation to verify the assumed value for  $j$ , as follows. Assume  $j = 0.90$ . Then

$$A_s = \frac{M}{f_s j d} = \frac{200 \times 12}{(20)(0.90)(33.5)} = 3.98 \text{ in.}^2 [2567 \text{ mm}^2]$$

and

$$\rho = \frac{A_s}{bd} = \frac{3.98}{(15)(33.5)} = 0.00792$$

Using this value for  $p$  in Figure 15.8, find  $k = 0.313$ . Using equation (15.2.6),  $j$  is found to be

$$j = 1 - \left(\frac{k}{3}\right) = 1 - \left(\frac{0.313}{3}\right) = 0.896$$

which is reasonably close to the assumption, so the computed area is adequate for design.

For beams that are classified as under-reinforced (section dimensions larger than the limit for a balanced section), a check should be made for the minimum required reinforcement. For the rectangular section, the ACI Code (Ref. 4) specifies that a minimum area be

$$A_s = \frac{3\sqrt{f'_c}}{f_y}(bd)$$

but not less than

$$A_s = \left(\frac{200}{F_y}\right)(bd)$$

On the basis of these requirements, values for the minimum reinforcement for rectangular sections with tension reinforcement only are given in Table 15.3 for the two common grades of steel and a range of concrete strengths.

For the example, with  $f'_c$  of 3000 psi and  $f_y$  of 40 ksi, the minimum area of steel is thus

$$A_s = 0.005(bd) = 0.005(15 \times 33.5) = 2.51 \text{ in.}^2$$

which is not critical in this case.

**TABLE 15.3 Minimum Required Tension Reinforcement for Rectangular Sections<sup>a</sup>**

$f'_c$ (psi)	$f_y = 40$ ksi	$f_y = 60$ ksi
3000	0.0050	0.00333
4000	0.0050	0.00333
5000	0.0053	0.00354

<sup>a</sup>Required  $A_s$  equals table value times  $bd$  of the beam.

**Problem 15.2.A**

A rectangular concrete beam has concrete with  $f'_c = 3000$  psi [20.7 MPa] and steel reinforcement with  $f_s = 20$  ksi [138 MPa]. Select the beam dimensions and reinforcement for a balanced section if the beam sustains a bending moment of 240 kip-ft [326 kN-m].

**Problem 15.2.B**

Same as Problem 15.2.A, except  $f'_c = 4000$  psi,  $f_s = 24$  ksi,  $M = 160$  kip-ft.

**Problem 15.2.C**

Find the area of steel required and select the bars for the beam in Problem 15.2.A if the section dimensions are  $b = 16$  in. and  $d = 32$  in.

**Problem 15.2.D**

Find the area of steel required and select the bars for the beam in Problem 15.2.B if the section dimensions are  $b = 14$  in. and  $d = 25$  in.

### 15.3 GENERAL APPLICATION OF STRENGTH METHODS

Application of the working stress method consists of designing members to work in an adequate manner (without exceeding established stress limits) under actual service load conditions. Strength design in effect consists of designing members to fail; thus, the ultimate strength of the member at failure (called its design strength) is the only type of resistance considered. The basic procedure of the strength method consists of determining a factored (increased) design load and comparing it to the factored (usually reduced) ultimate resistance of the structural member.

The ACI Code (Ref. 4) provides various combinations of loads that must be considered for design. Each type of load (live, dead, wind, earthquake, snow, etc.) is given an individual factor in these load equations. For an example, with only live and dead load considered, the equation for the factored design load  $U$  is

$$U = 1.4D + 1.7L$$

in which

$D$  = the effect of dead load

$L$  = the effect of live load

The design strength of individual members (i.e., their usable ultimate strength) is determined by the application of assumptions and requirements given in the code and is further modified by the use of a strength reduction factor  $\phi$  as follows:

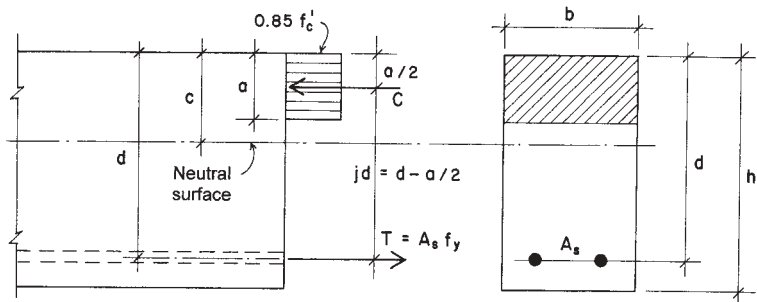
- $\phi = 0.90$  for flexure, axial tension, and combinations of flexure and tension
- $= 0.75$  for columns with spirals
- $= 0.70$  for columns with ties
- $= 0.85$  for shear and torsion
- $= 0.70$  for compressive bearing
- $= 0.65$  for flexure in plain (not reinforced) concrete

Thus, while the formulas for  $U$  may imply a somewhat low safety factor, an additional margin of safety is provided by the strength reduction factors.

#### 15.4 FLEXURE: STRENGTH METHOD

Figure 15.11 shows the rectangular “stress block” that is used for analysis of the rectangular section with tension reinforcing only by the strength method. This is the basis for investigation and design as provided for in the ACI Code (Ref. 4).

The rectangular stress block is based on the assumption that a concrete stress of  $0.85f'_c$  is uniformly distributed over the compression zone,



**Figure 15.11** Development of bending resistance: strength method.



which has dimensions equal to the beam width  $b$  and the distance  $a$  that locates a line parallel to and above the neutral axis. The value of  $a$  is determined from the expression  $a = \beta_1 \times c$ , where  $\beta_1$  (beta one) is a factor that varies with the compressive strength of the concrete, and  $c$  is the distance from the extreme fiber to the neutral axis. For concrete having  $f'_c$  equal to or less than 4000 psi [27.6 MPa], the Code gives a maximum value for  $a = 0.85c$ .

With the rectangular stress block, the magnitude of the compressive force in the concrete is expressed as

$$C = (0.85f'_c)(b)(a)$$

and it acts at a distance of  $a/2$  from the top of the beam. The arm of the resisting force couple then becomes  $d - (a/2)$ , and the developed resisting moment as governed by the concrete is

$$M_c = C \left[ d - \left( \frac{a}{2} \right) \right] = 0.85f'_c ba \left[ d - \left( \frac{a}{2} \right) \right] \quad (15.4.1)$$

With  $T$  expressed as  $A_s \times f_y$ , the developed moment as governed by the reinforcement is

$$M_t = T \left[ d - \left( \frac{a}{2} \right) \right] = A_s f_y \left[ d - \left( \frac{a}{2} \right) \right] \quad (15.4.2)$$

A formula for the dimension  $a$  of the stress block can be derived by equating the compression and tension forces; thus,

$$0.85f'_c ba = A_s f_y, \quad a = \frac{A_s f_y}{0.85f'_c b} \quad (15.4.3)$$

By expressing the area of steel in terms of a percentage  $p$ , the formula for  $a$  may be modified as follows:

$$p = \frac{A_s}{bd}, \quad A_s = pbd,$$

$$a = \frac{(pbd)(f_y)}{0.85f'_c b} = \frac{pdf_y}{0.85f'_c} \quad (15.4.4)$$

The balanced section for strength design is visualized in terms of strain rather than stress. The limit for a balanced section is expressed in the form of the percentage of steel required to produce balanced conditions. The formula for this percentage is

$$p_b = \left( 0.85 f'_c / f_y \right) \times \left[ \frac{87}{(87 + f_y)} \right] \quad (15.4.5)$$

in which  $f'_c$  and  $f_y$  are in units of ksi. Although this is a precise formula, it is advisable to limit the percentage of steel to 75% of this balanced value in beams with tension reinforcing only.

Returning to the formula for the developed resisting moment, as expressed in terms of the steel, a useful formula may be derived as follows:

$$\begin{aligned} M_t &= A_s f_y \left[ d - \left( \frac{a}{2} \right) \right] \\ &= (pbd)(f_y) \left[ d - \left( \frac{a}{2} \right) \right] \\ &= (pbd)(f_y)(d) \left[ 1 - \left( \frac{a}{2d} \right) \right] \\ &= (bd^2) \left\{ pf_y \left[ 1 - \left( \frac{a}{2d} \right) \right] \right\} \end{aligned}$$

Thus,

$$M_t = Rbd^2 \quad (15.4.6)$$

where

$$R = pf_y \left[ 1 - \left( \frac{a}{2d} \right) \right] \quad (15.4.7)$$

With the reduction factor applied, the design moment for a section is limited to nine-tenths of the theoretical resisting moment.

Values for the balanced section factors ( $p$ ,  $R$ , and  $a/d$ ) are given in Table 15.4 for various combinations of  $f'_c$  and  $f_y$ . The balanced section, as discussed in the preceding section, is not necessarily a practical one for design. In most cases, economy will be achieved by using less than the balanced reinforcing for a given concrete section. In special circum-

**TABLE 15.4** Balanced Section Properties for Rectangular Sections with Tension Reinforcement Only: Strength Method

$f_y$		$f'_c$		Balanced $a/d$	Usable $a/d$ (75% Balanced)	Usable $p$	Usable $R$	
ksi	MPa	ksi	MPa				ksi	kPa
40	276	2	13.79	0.5823	0.4367	0.0186	0.580	4000
		3	20.68	0.5823	0.4367	0.0278	0.870	6000
		4	27.58	0.5823	0.4367	0.0371	1.161	8000
		5	34.48	0.5480	0.4110	0.0437	1.388	9600
60	414	2	13.79	0.5031	0.3773	0.0107	0.520	3600
		3	20.68	0.5031	0.3773	0.0160	0.781	5400
		4	27.58	0.5031	0.3773	0.0214	1.041	7200
		5	34.48	0.4735	0.3551	0.0252	1.241	8600

stances, it may also be possible, or even desirable, to use compressive reinforcing in addition to tension reinforcing. Nevertheless, just as in the working stress method, the balanced section is often a useful reference when design is performed.

The following example illustrates a procedure for the design of a simple rectangular beam section with tension reinforcing only.

**Example 3.** The service load bending moments on a beam are 58 kip-ft [78.6 kN-m] for dead load and 38 kip-ft [51.5 kN-m] for live load. The beam is 10 in. [254 mm] wide,  $f'_c$  is 4000 psi [27.6 MPa], and  $f_y$  is 60 ksi [414 MPa]. Determine the depth of the beam and the tensile reinforcing required.

*Solution:* The first step is to determine the required moment, using the load factors. Thus,

$$\begin{aligned}
 U &= 1.4D + 1.7L \\
 M_u &= 1.4(M_{DL}) + 1.7(M_{LL}) \\
 &= 1.4(58) + 1.7(38) = 145.8 \text{ kip-ft [197.7 kN-m]}
 \end{aligned}$$

With the capacity reduction of 0.90 applied, the desired moment capacity of the section is determined as

$$\begin{aligned}
 M_t &= \frac{M_u}{0.90} = \frac{145.8}{0.90} = 162 \text{ kip-ft} \\
 &= 162 \times 12 = 1944 \text{ kip-in. [220 kN-m]}
 \end{aligned}$$

The maximum usable reinforcement ratio, as given in Table 15.4, is  $p = 0.0214$ . If a balanced section is used, the required area of reinforcement may thus be determined from the relationship

$$A_s = pbd$$

While there is nothing especially desirable about a balanced section, it does represent the beam section with least depth if tension reinforcing only is used. Therefore, proceed to find the required balanced section for this example.

To determine the required effective depth  $d$ , use equation (15.4.6); thus,

$$M_1 = Rbd^2$$

With the value of  $R = 1.041$  from Table 15.4,

$$M_1 = 1944 = 1.041(10)(d)^2$$

and

$$d = \sqrt{\frac{1944}{1.041(10)}} = \sqrt{186.7} = 13.66 \text{ in. [347 mm]}$$

If this value is used for  $d$ , the required steel area may be found as

$$A_s = pbd = 0.0214(10)(13.66) = 2.92 \text{ in.}^2 \text{ [1880 mm}^2\text{]}$$

From Table 15.4, the minimum ratio of reinforcing is 0.00333, which is clearly not critical for this example.

Selection of the actual beam dimensions and the actual number and size of reinforcing bars involves various considerations, as discussed in Section 15.2.

If there are reasons, as there often are, for not selecting the least deep section with the greatest amount of reinforcing, a slightly different procedure must be used, as illustrated in the following example.

**Example 4.** Using the same data as in Example 3, find the reinforcement required if the desired beam section has  $b = 10$  in. [254 mm] and  $d = 18$  in. [457 mm].

*Solution:* The first two steps in this situation would be the same as in Example 1—to determine  $M_u$  and  $M_r$ . The next step would be to determine whether the given section is larger than, smaller than, or equal to a balanced section. Since this investigation has already been done in Example 1, observe that the  $10 \times 18$  in. section is larger than a balanced section. Thus, the actual value of  $a/d$  will be less than the balanced section value of 0.3773. The next step would then be as follows:

Estimate a value for  $a/d$ —something smaller than the balanced value. For example, try  $a/d = 0.25$ . Then

$$a = 0.25d = 0.25(18) = 4.5 \text{ in. [114 mm]}$$

With this value for  $a$ , use equation (15.4.2) to find a required value for  $A_s$ . Referring to Figure 15.11,

$$M_t = T(jd) = A_s F_y \left[ d - \left( \frac{a}{2} \right) \right]$$

$$A_s = \frac{M_t}{f_y \left[ d - (a/2) \right]} = \frac{1944}{60(15.75)} = 2.057 \text{ in.}^2 \text{ [1327 mm}^2\text{]}$$

Next, test to see if the estimate for  $a/d$  was close by finding  $a/d$  using equation (15.4.4). Thus,

$$p = \frac{A_s}{bd} = \frac{2.057}{10(18)} = 0.0114$$

and

$$a = \frac{pf_y}{0.85f'_c}$$

$$\frac{a}{d} = \frac{pf_y}{0.85f'_c} = \frac{0.0114(60)}{0.85(4)} = 0.202$$

Thus,

$$a = 0.202(18) = 3.63 \text{ in.}, \quad d - \left( \frac{a}{2} \right) = 16.2 \text{ in. [400 mm]}$$

If this value for  $d - (a/2)$  is used to replace that used earlier, the required value of  $A_s$  will be slightly reduced. In this example, the correction will be only a few percent. If the first guess of  $a/d$  had been way off, it might have justified another run through the analysis to get closer to an exact answer.

### Problems 15.4.A–C

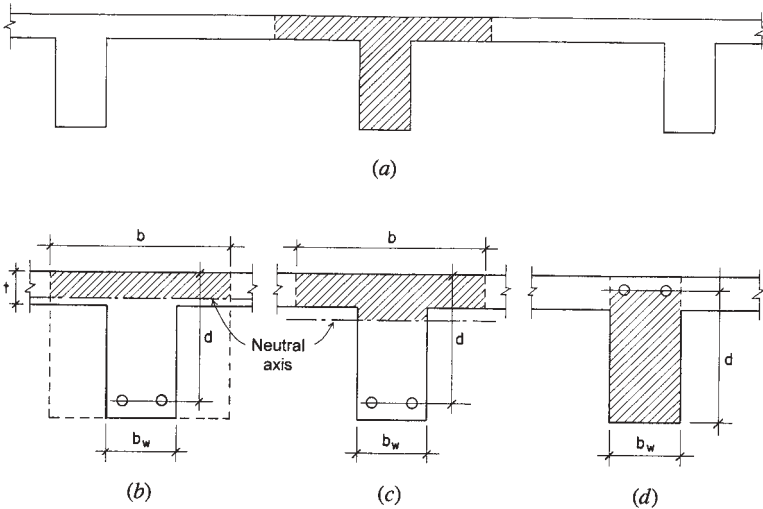
Using  $f'_c = 3$  ksi [20.7 MPa] and  $f_y = 60$  ksi [414 MPa], find the minimum depth required for a balanced section for the given data. Also find the area of reinforcement required if the depth chosen is 1.5 times that required for the balanced section. Use strength design methods.

	Moment Due to:					
	Dead Load		Live Load		Beam Width	
	kip-ft	kN-m	kip-ft	kN-m	(in.)	(mm)
A	40	54.2	20	27.1	12	305
B	80	108.5	40	54.2	15	381
C	100	135.6	50	67.8	18	457

## 15.5 T-BEAMS

When a floor slab and its supporting beams are cast at the same time, the result is monolithic construction in which a portion of the slab on each side of the beam serves as the flange of a T-beam. The part of the section that projects below the slab is called the web or stem of the T-beam. This type of beam is shown in Figure 15.12a. For positive moment, the flange is in compression and there is ample concrete to resist compressive stresses, as shown in Figures 15.12b or c. However, in a continuous beam, there are negative bending moments over the supports, and the flange here is in the tension stress zone with compression in the web.

It is important to remember that only the area formed by the width of the web  $b_w$  and the effective depth  $d$  is to be considered in computing resistance to shear and to bending moment over the supports. This is the hatched area shown in Figure 15.12d.



**Figure 15.12** Considerations for T-beams.

The effective flange width ( $b_f$ ) to be used in the design of symmetrical T-beams is limited to one-fourth the span length of the beam. In addition, the overhanging width of the flange on either side of the web is limited to eight times the thickness of the slab or one-half the clear distance to the next beam.

In monolithic construction with beams and one-way solid slabs, the effective flange area of the T-beams is usually quite capable of resisting the compressive stresses caused by positive bending moments. With a large flange area, as shown in Figure 15.12a, the neutral axis of the section usually occurs quite high in the beam web. If the compression developed in the web is ignored, the net compression force may be considered to be located at the centroid of the trapezoidal stress zone that represents the stress distribution in the flange. On this basis, the compression force is located at something less than  $t/2$  from the top of the beam.

It is possible to conduct an approximate analysis of the T-section by the working stress method while avoiding the need to find the location of the neutral axis and the centroid of the trapezoidal stress zone; the procedure consists of the following steps.

1. Determine the effective flange width for the T, as previously described.
2. Ignore compression in the web and assume a constant value for compressive stress in the flange (see Figure 15.13). Thus,

$$jd = d - \left(\frac{t}{2}\right)$$

Then, find the required steel area as

$$A_s = \frac{M}{f_s jd} = \frac{M}{f_s [d - (t/2)]}$$

3. Check the compressive stress in the concrete as

$$f_c = \frac{C}{b_f t}$$

where

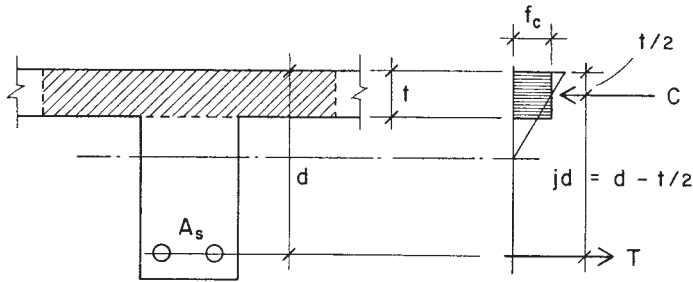
$$C = \frac{M}{jd} = \frac{M}{d - (t/2)}$$

The actual value of maximum compressive stress will be slightly higher, but will not be critical if this computed value is significantly less than the limit of  $0.45f'_c$ .

4. T-beams ordinarily function for positive moments in continuous beams. Since these moments are typically less than those at the beam supports, and the required section is typically derived for the more critical bending at the supports, the T-beam is typically considerably under-reinforced. This makes it necessary to consider the problem of minimum reinforcement, as discussed for the rectangular section. The ACI Code (Ref. 4) provides special requirements for this for the T-beam, for which the minimum area required is defined as the greater value of

$$A_s = \frac{6\sqrt{f'_c}}{f_y}(b_w d)$$





**Figure 15.13** Basis for simplified analysis of a T-beam.

or

$$A_s = \frac{3\sqrt{f'_c}}{f_y} (b_f d)$$

in which:

$b_w$  = the width of the beam web

$b_f$  = the effective width of the T-flange

The following example illustrates the use of this procedure. It assumes a typical design situation in which the dimensions of the section ( $b_f$ ,  $b_w$ ,  $d$ , and  $t$ ) are all predetermined by other design considerations and the design of the T-section is reduced to the work of determining the required area of tension reinforcement.

**Example 5.** A T-section is to be used for a beam to resist positive moment. The following data are given: beam span = 18 ft [5.49 m], beams are 9 ft [2.74 m] center to center, slab thickness is 4 in. [0.102 m], beam stem dimensions are  $b_w = 15$  in. [0.381 m], and  $d = 22$  in. [0.559 m],  $f'_c = 4$  ksi [27.6 MPa],  $f_y = 60$  ksi [414 MPa],  $f_s = 24$  ksi [165 MPa]. Find the required area of steel and select reinforcing bars for a moment of 200 kip-ft [272 kN-m].

**Solution:** Determine the effective flange width (necessary only for a check on the concrete stress). The maximum value for the flange width is

$$b_f = \frac{\text{beam span}}{4} = \frac{18 \times 12}{4} = 54 \text{ in. [1.37 m]}$$

or

$$b_f = \text{center-to-center beam spacing} = 9(12) = 108 \text{ in. [2.74 m]}$$

or

$$b_f = \text{beam stem width plus 16 times the slab thickness} = 15 + 16(4) = 79 \text{ in. [201 m]}$$

The limiting value is therefore 54 in. [1.37 m].

Next, find the required steel area as

$$A_s = \frac{M}{f_s [d - (t/2)]} = \frac{200 \times 12}{24[22 - (4/2)]} = 5.00 \text{ in.}^2 [3364 \text{ mm}^2]$$

Select bars using Table 15.5, which incorporates consideration for the adequacy of the stem width. From the table, choose five No. 9 bars, actual  $A_s = 5.00 \text{ in.}^2$ . Consideration for the beam width and adequate spacing of the bars is discussed in Example 1 in Section 15.2.

Check the concrete stress:

$$C = \frac{M}{jd} = \frac{200 \times 12}{20} = 120 \text{ kips [535 kN]}$$

$$f_c = \frac{C}{b_f t} = \frac{120}{54 \times 4} = 0.556 \text{ ksi [3.83 MPa]}$$

**TABLE 15.5 Options for the T-Beam Reinforcement**

Bar Size	Number of Bars	Actual Area Provided (in. <sup>2</sup> )	Width Required (in.)
7	9	5.40	22
8	7	5.53	17
9	5	5.00	14
10	4	5.08	13
11	4	6.28	14

Compare this to the limiting stress of

$$0.45f'_c = 0.45(4) = 1.8 \text{ ksi [12.4 MPa]}$$

Thus, compressive stress in the flange is clearly not critical.

Using the beam stem width of 15 in. and the effective flange width of 54 in., the minimum area of reinforcement is determined as the greater of

$$A_s = \frac{6\sqrt{f'_c}}{f_y}(b_w d) = \frac{6\sqrt{4000}}{60,000}(15)(22) = 2.09 \text{ in.}^2 \text{ [1350 mm}^2\text{]}$$

or

$$A_s = \frac{3\sqrt{f'_c}}{f_y}(b_f d) = \frac{3\sqrt{4000}}{60,000}(54)(22) = 2.56 \text{ in.}^2 \text{ [1650 mm}^2\text{]}$$

As both of these are less than the computed area, minimum area is not critical in this case.

The example in this section illustrates a procedure that is reasonably adequate for beams that occur in ordinary beam and slab construction. When special T-sections occur with thin flanges ( $t$  less than  $d/8$  or so), these methods may not be valid. In such cases, more accurate investigation should be performed, using the requirements of the ACI Code (Ref. 4).

### **Problem 15.5.A**

Find the area of steel reinforcement required for a concrete T-beam for the following data:  $f'_c = 3$  ksi, allowable  $f_s = 20$  ksi [138 MPa],  $d = 28$  in. [711 mm],  $t = 6$  in. [152 mm],  $b_w = 16$  in. [406 mm], and the section sustains a bending moment of 240 kip-ft [326 kN-m].

### **Problem 15.5.B**

Same as Problem 15.5.A, except  $f'_c = 4$  ksi,  $f_s = 24$  ksi,  $d = 32$  in.,  $t = 5$  in.,  $b_w = 18$  in.,  $M = 320$  kip-ft.

## **15.6 SHEAR IN CONCRETE BEAMS**

From general consideration of shear effects, as developed in the science of mechanics of materials, the following observations can be made:

1. Shear is an ever-present phenomenon, produced directly by slicing actions, by transverse loading in beams, and on oblique sections in tension and compression members.
2. Shear forces produce shear stress in the plane of the force and equal unit shear stresses in planes that are perpendicular to the shear force.
3. Diagonal stresses of tension and compression, having magnitudes equal to that of the shear stress, are produced in directions of  $45^\circ$  from the plane of the shear force.
4. Direct slicing shear force produces a constant magnitude shear stress on affected sections, but beam shear action produces shear stress that varies on the affected sections, having magnitude of zero at the edges of the section and a maximum value at the centroidal neutral axis of the section.

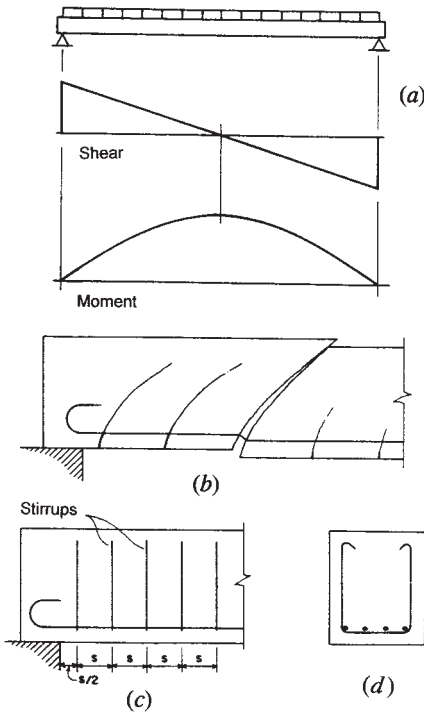
In the discussions that follow it is assumed that the reader has a general familiarity with these relationships.

Consider the case of a simple beam with uniformly distributed load and end supports that provides only vertical resistance (no moment restraint). The distribution of internal shear and bending moment are as shown in Figure 15.14*a*. For flexural resistance, it is necessary to provide longitudinal reinforcing bars near the bottom of the beam. These bars are oriented for primary effectiveness in resistance to tension stresses that develop on a vertical ( $90^\circ$ ) plane (which is the case at the center of the span, where the bending moment is maximum and the shear approaches zero).

Under the combined effects of shear and bending, the beam tends to develop tension cracks, as shown in Figure 15.14*b*. Near the center of the span, where the bending is predominant and the shear approaches zero, these cracks approach  $90^\circ$ . Near the support, however, where the shear predominates and bending approaches zero, the critical tension stress plane approaches  $45^\circ$ , and the horizontal bars are only partly effective in resisting the cracking.

### Shear Reinforcement for Beams

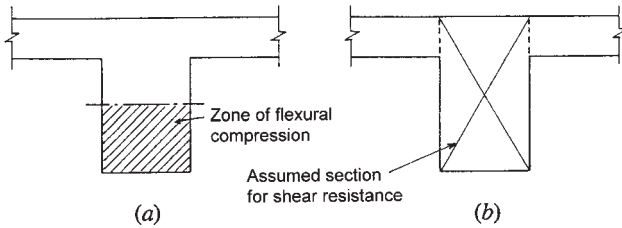
For beams, the most common form of added shear reinforcement consists of a series of U-shaped bent bars (Figure 15.14*d*), placed vertically and



**Figure 15.14** Considerations for shear in concrete beams.

spaced along the beam span, as shown in Figure 15.14c. These bars, called *stirrups*, are intended to provide a vertical component of resistance, working in conjunction with the horizontal resistance provided by the flexural reinforcement. In order to develop flexural tension near the support face, the horizontal bars must be anchored in the concrete beyond the point where the stress is developed. Where the ends of simple beams extend only a short distance over the support (a common situation), it is often necessary to bend or hook the bars to achieve adequate anchorage, as shown in Figure 15.14c.

The simple span beam and the rectangular section shown in Figure 15.14d occur only infrequently in building structures. The most common case is that of the beam section shown in Figure 15.15a, which occurs when a beam is cast continuously with a supported concrete slab. In addition, these beams normally occur in continuous spans with negative



**Figure 15.15** Development of negative bending moment and shear in concrete T-beams.

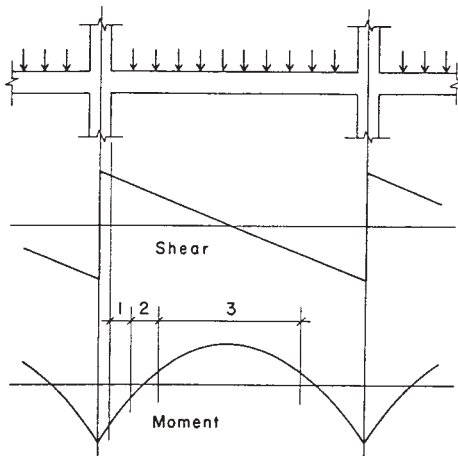
moments at the supports. Thus, the stress in the beam near the support is as shown in Figure 15.15a, with the negative moment producing compressive flexural stress in the bottom of the beam stem. This is substantially different from the case of the simple beam, where the moment approaches zero near the support.

For the purpose of shear resistance, the continuous T-shaped beam is considered to consist of the section indicated in Figure 15.15b. The effect of the slab is ignored, and the section is considered to be a simple rectangular one. Thus, for shear design, there is little difference between the simple span beam and the continuous beam, except for the effect of the continuity on the distribution of internal shear forces along the beam span. It is important, however, to understand the relationships between shear and moment in the continuous beam.

Figure 15.16 illustrates the typical condition for an interior span of a continuous beam with uniformly distributed load. Referring to the portions of the beam span numbered 1, 2, and 3 on the moment diagram:

1. In zone 1, the high negative moment requires major flexural reinforcing consisting of horizontal bars near the top of the beam.
2. In zone 2, the moment reverses sign; moment magnitudes are low; and, if shear stress is high, the design for shear is a predominant concern.
3. In zone 3, shear consideration is minor and the predominant concern is for positive moment requiring major flexural reinforcing in the bottom of the beam.

(Note: See Figure 15.3f for a typical layout of flexural reinforcement in a continuous beam.)



**Figure 15.16** Shear and bending in continuous concrete beams.

Vertical U-shaped stirrups, similar to those shown in Figure 15.17a, may be used in the T-shaped beam. An alternate detail for the U-shaped stirrup is shown in Figure 15.17b, in which the top hooks are turned outward; this makes it possible to spread the negative moment reinforcing bars to make placing of the concrete somewhat easier. Figures 15.17c and d show possibilities for stirrups in L-shaped beams that occur at the edges of large openings or at the outside edge of the structure. This form of stirrup is used to enhance the torsional resistance of the section, and also assists in developing the negative moment resistance in the slab at the edge of the beam.

So-called *closed stirrups*, similar to ties in columns, are sometimes used for T- and L-shaped beams, as shown in Figures 15.17c through f. These are generally used to improve the torsional resistance of the beam section.

Stirrup forms are often modified by designers or by the reinforcing fabricator's detailers to simplify the fabrication and/or the field installation. The stirrups shown in Figures 15.17d and f are two such modifications of the basic details in Figures 15.17c and e, respectively.

## Design Considerations

The following are some of the general considerations and code requirements that apply to current practices of design for beam shear.

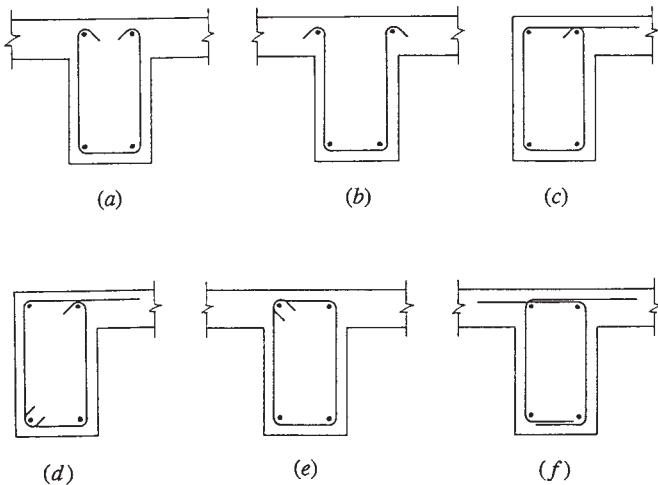


Figure 15.17 Forms for vertical stirrups.

**Concrete Capacity.** Whereas the tensile strength of the concrete is ignored in design for flexure, the concrete is assumed to take some portion of the shear in beams. If the capacity of the concrete is not exceeded—as is sometimes the case for lightly loaded beams—there may be no need for reinforcement. The typical case, however, is as shown in Figure 15.18, where the maximum shear  $V$  exceeds the capacity of the concrete alone ( $V_c$ ), and the steel reinforcement is required to absorb the excess, indicated as the shaded portion in the shear diagram.

**Minimum Shear Reinforcement.** Even when the maximum computed shear stress falls below the capacity of the concrete, the present code requires the use of some minimum amount of shear reinforcement. Exceptions are made in some situations, such as for slabs and very shallow beams. The objective is essentially to toughen the structure with a small investment in additional reinforcement.

**Type of Stirrup.** The most common stirrups are the simple U-shaped or closed forms shown in Figure 15.17, placed in a vertical position at intervals along the beam. It is also possible to place stirrups at an incline (usually  $45^\circ$ ), which makes them somewhat more effective in direct resistance to the potential shear cracking near the beam ends (see Figure



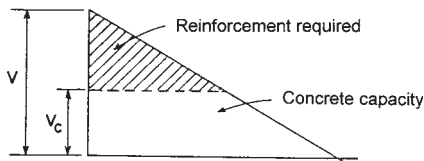
15.14*b*). In large beams with excessively high unit shear stress, both vertical and inclined stirrups are sometimes used at the location of the greatest shear.

**Size of Stirrups.** For beams of moderate size, the most common size for U-stirrups is a No. 3 bar. These bars can be bent relatively tightly at the corners (small radius of bend) in order to fit within the beam section. For larger beams, a No. 4 bar is sometimes used, its strength (as a function of its cross-sectional area) being almost twice that of a No. 3 bar.

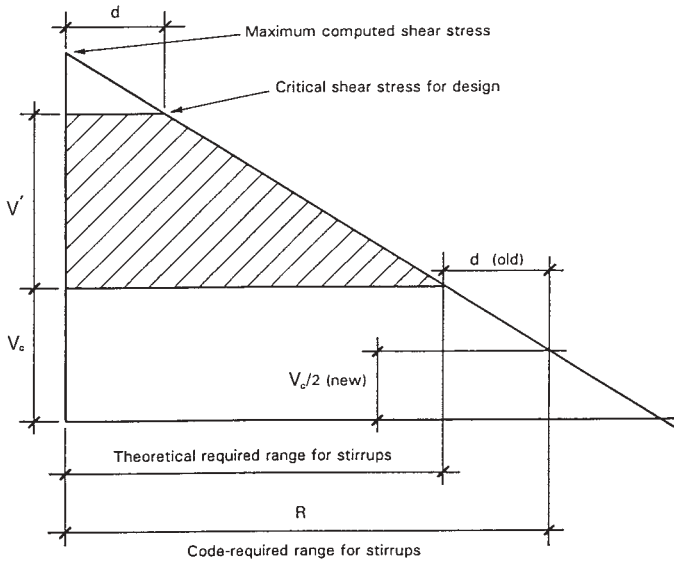
**Spacing of Stirrups.** Stirrup spacings are computed (as discussed in the following sections) on the basis of the amount of reinforcing required for the unit shear stress at the location of the stirrups. A maximum spacing of  $d/2$  (i.e., one-half the effective beam depth  $d$ ) is specified in order to ensure that at least one stirrup occurs at the location of any potential diagonal crack (see Figure 15.14*b*). When shear stress is excessive, the maximum spacing is limited to  $d/4$ .

**Critical Maximum Design Shear.** Although the actual maximum shear value occurs at the end of the beam, the ACI Code (Ref. 4) permits the use of the shear stress at a distance of  $d$  (effective beam depth) from the beam end as the critical maximum for stirrup design. Thus, as shown in Figure 15.19, the shear requiring reinforcing is slightly different from that shown in Figure 15.18.

**Total Length for Shear Reinforcement.** On the basis of computed shear stresses, reinforcement must be provided along the beam length for the distance defined by the shaded portion of the shear stress diagram shown in Figure 15.19. For the center portion of the span, the concrete is theoretically capable of the necessary shear resistance without the assistance of reinforcement. However, the code requires that some



**Figure 15.18** Sharing of shear resistance in reinforced concrete beams.



**Figure 15.19** Layout for shear stress analysis: ACI Code requirements.

shear reinforcement be provided for a distance beyond this computed cut-off point. Earlier codes required that stirrups be provided for a distance equal to the effective depth of the beam beyond the computed cutoff point. Currently, codes require that minimum shear reinforcement be provided as long as the computed shear stress exceeds one-half of the capacity of the concrete. However it is established, the total extended range over which reinforcement must be provided is indicated as  $R$  on Figure 15.19.

### 15.7 DESIGN FOR SHEAR IN CONCRETE BEAMS

The following is a description of the procedure for design of shear reinforcement for beams that is in compliance with Appendix A of the 1995 ACI Code (Ref. 4).

Shear stress is computed as

$$v = \frac{V}{bd}$$

in which

$V$  = total shear force at the section

$b$  = beam width (of the stem for T-shapes)

$d$  = effective depth of the section

For beams of normal weight concrete, subjected only to flexure and shear, shear stress in the concrete is limited to

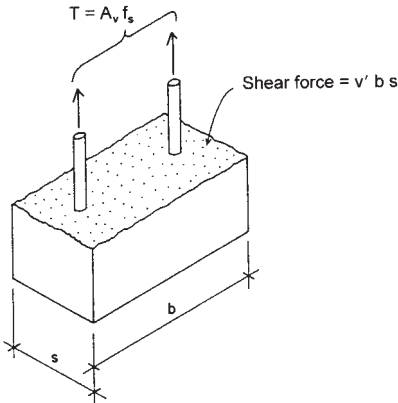
$$v_c = 1.1\sqrt{f'_c}$$

When  $v$  exceeds the limit for  $v_c$ , reinforcement must be provided, complying with the general requirements discussed previously. Although the code does not use the term, the notation of  $v'$  is used here for the excess unit shear for which reinforcement is required. Thus,

$$v' = v - v_c$$

Required spacing of shear reinforcement is determined as follows. Referring to Figure 15.20, note that the capacity in tensile resistance of a single, two-legged stirrup is equal to the product of the total steel cross-sectional area  $A_v$  times the allowable steel stress. Thus,

$$T = A_v f_s$$



**Figure 15.20** Consideration for spacing of a single stirrup.

This resisting force opposes the development of shear stress on the area  $s$  times  $b$ , in which  $b$  is the width of the beam and  $s$  is the spacing (half the distance to the next stirrup on each side). Equating the stirrup tension to this force, an equilibrium equation is obtained:

$$A_v f_s = bsv'$$

From this equation, an expression for the required spacing can be derived; thus,

$$s = \frac{A_v f_s}{v'b}$$

The following examples illustrate the design procedure for a simple beam.

**Example 6.** Design the required shear reinforcement for the simple beam shown in Figure 15.21a. Use  $f'_c = 3$  ksi [20.7 MPa] and  $f_s = 20$  ksi [138 MPa] and single U-shaped stirrups.

*Solution:* The maximum value for the shear is 40 kips [178 kN], and the maximum value for shear stress is computed as

$$v = \frac{V}{bd} = \frac{40,000}{12 \times 24} = 139 \text{ psi [957 KPa]}$$

Now construct the shear stress diagram for one-half of the beam, as shown in Figure 15.21c. For the shear design, the critical shear stress is at 24 in. (the effective depth of the beam) from the support. Using proportionate triangles, this value is

$$\left(\frac{72}{96}\right)(139) = 104 \text{ psi [718 kPa]}$$

The capacity of the concrete without reinforcing is

$$v_c = 1.1\sqrt{f'_c} = 1.1\sqrt{3000} = 60 \text{ psi [414 KPa]}$$

At the point of critical stress, therefore, there is an excess shear stress of  $104 - 60 = 44$  psi [ $718 - 414 = 304$  kPa] that must be carried by

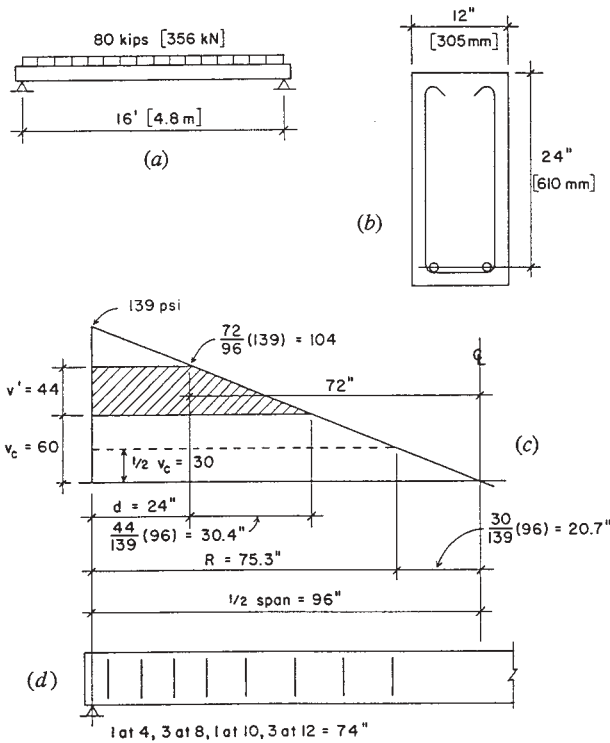


Figure 15.21 Example 6.

reinforcement. Next, complete the construction of the diagram in Figure 15.21c to define the shaded portion, which indicates the extent of the required reinforcement. Observe that the excess shear condition extends to 54.4 in. [1.382 m] from the support.

In order to satisfy the requirements of the ACI Code, shear reinforcement must be used wherever the computed unit stress exceeds one-half of  $v_c$ . As shown in Figure 15.21c, this is a distance of 75.3 in. from the support. The code further stipulates that the minimum cross-sectional area of this reinforcing be

$$A_v = 50 \left( \frac{bs}{f_y} \right)$$

Assuming an  $f_y$  value of 40 ksi [276 MPa] and the maximum allowable spacing of one-half the effective depth, the required area is

$$A_v = 50 \left( \frac{12 \times 12}{40,000} \right) = 0.18 \text{ in.}^2$$

which is less than the area of  $2 \times 0.11 = 0.22 \text{ in.}^2$  provided by the two legs of the No. 3 stirrup.

For the maximum  $v'$  value of 44 ksi, the maximum spacing permitted is determined as

$$s = \frac{A_v f_s}{v' b} = \frac{0.22 \times 20,000}{44 \times 12} = 8.3 \text{ in.}$$

Since this is less than the maximum allowable of one-half the depth or 12 in., it is best to calculate at least one more spacing at a short distance beyond the critical point. For example, at 36 in. from the support, the stress is

$$v = \left( \frac{60}{96} \right) (139) = 87 \text{ psi}$$

and the value of  $v'$  at this point is  $87 - 60 = 27 \text{ psi}$ . The spacing required at this point is thus

$$s = \frac{A_v f_s}{v' b} = \frac{0.22 \times 20,000}{27 \times 10} = 13.6 \text{ in.}$$

which indicates that the required spacing drops to the maximum allowed at less than 12 in. from the critical point. A possible choice for the stirrup spacings is shown in Figure 15.21*d*, with a total of eight stirrups that extend over a range of 74 in. from the support. There are thus a total of 16 stirrups in the beam, 8 at each end. Note that the first stirrup is placed at 4 in. from the support, which is one-half the computed required spacing; this is a common practice with designers.

**Example 7.** Determine the required number and spacings for No. 3 U-stirrups for the beam shown in Figure 15.22. Use  $f'_c = 3 \text{ ksi}$  [20.7 MPa] and  $f_s = 20 \text{ ksi}$  [138 MPa].

*Solution:* As in Example 1, the shear values and corresponding stresses are determined, and the diagram in Figure 15.22c. is constructed. In this case, the maximum critical shear stress of 89 psi results in a maximum  $v'$  value to 29 psi, for which the required spacing is

$$s = \frac{A_v f_s}{v' b} = \frac{0.22 \times 20,000}{29 \times 10} = 15.2 \text{ in.}$$

Since this value exceeds the maximum limit of  $d/2 = 10$  in., the stirrups may all be placed at the limited spacing, and a possible arrangement is as shown in Figure 15.22d. As in Example 6, note that the first stirrup is placed at one-half the required distance from the support.

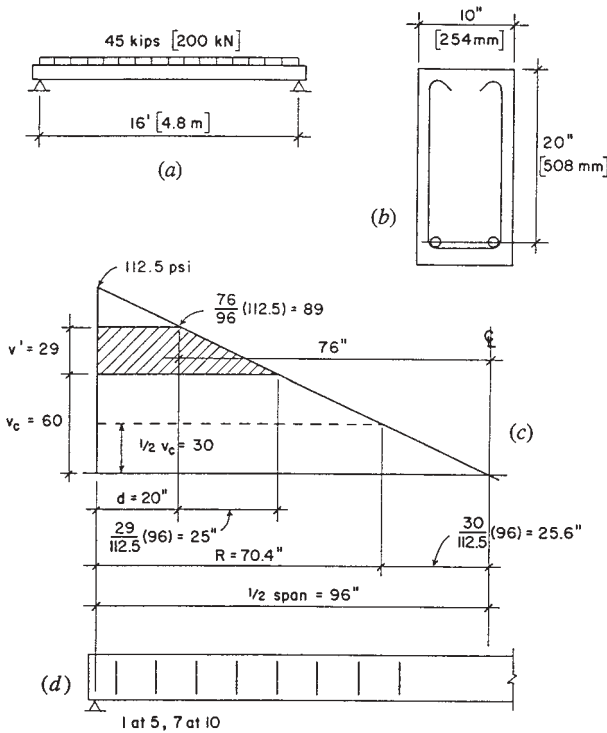


Figure 15.22 Example 7.

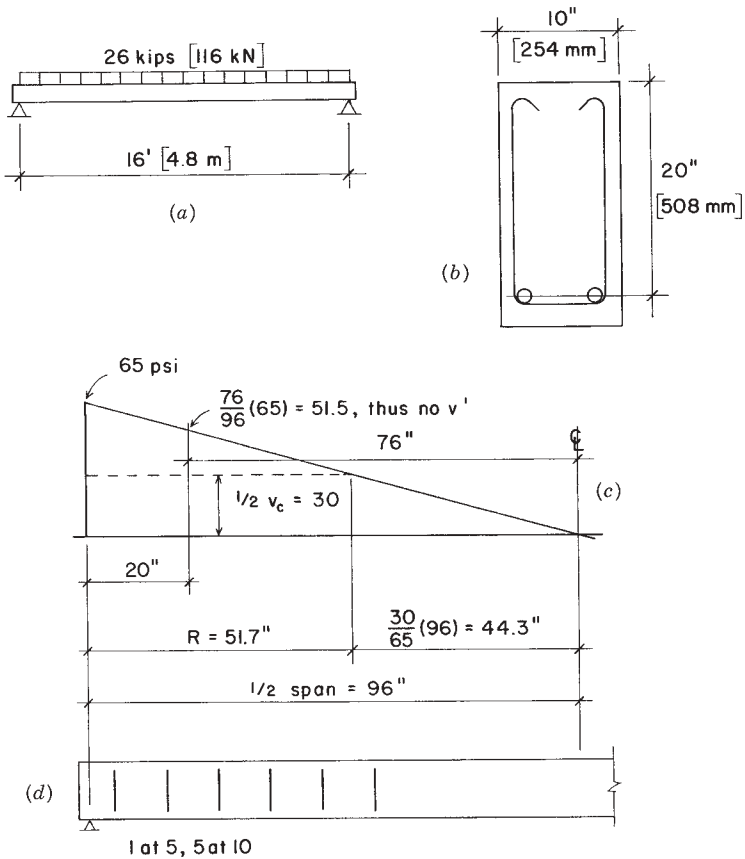


Figure 15.23 Example 8.

**Example 8.** Determine the required number and spacings for No. 3 U-stirrups for the beam shown in Figure 15.23. Use  $f'_c = 3 \text{ ksi [20.7 MPa]}$  and  $f_s = 20 \text{ ksi [138 MPa]}$ .

**Solution:** In this case, the maximum critical design shear stress is found to be less than  $v_c$ , which in theory indicates that reinforcement is not required. To comply with the code requirement for minimum reinforcement, however, provide stirrups at the maximum permitted spacing out to



the point where the shear stress drops to 30 psi (one-half of  $v_c$ ). To verify that the No. 3 stirrup is adequate, compute

$$A_v = 50 \left( \frac{bs}{f_y} \right) = 50 \left( \frac{10 \times 10}{40,000} \right) = 0.125 \text{ in.}^2 \text{ (See Example 6)}$$

which is less than the area provided, so the No. 3 stirrup at 10-in. is adequate.

**Problem 15.7.A**

A concrete beam similar to that shown in Figure 15.21 sustains a total load of 60 kips [267 kN] on a span of 24 ft [7.32 m]. Determine the layout for a set of No. 3 U-stirrups with  $f_s = 20$  ksi [138 MPa] and  $f_c' = 3000$  psi [20.7 MPa]. The beam section dimensions are  $b = 12$  in. [305 mm] and  $d = 26$  in. [660 mm].

**Problem 15.7.B**

Same as Problem 15.7.A, except load is 50 kips [222 kN], span is 20 ft [6.1 m],  $b = 10$  in. [254 mm],  $d = 23$  in. [584 mm].

**Problem 15.7.C**

Determine the layout for a set of No. 3 U-stirrups for a beam with the same data as Problem 15.7.A, except the total load on the beam is 30 kips [133 kN].

**Problem 15.7.D**

Determine the layout for a set of No. 3 U-stirrups for a beam with the same data as Problem 15.7.B, except the total load on the beam is 25 kips [111 kN].

---

## REFERENCES

---

1. *Uniform Building Code, Volume 2: Structural Engineering Design Provisions*, 1997 ed., International Conference of Building Officials, Whittier, CA. (Called simply the UBC.)
2. *National Design Specification for Wood Construction (NDS)*, 1997 ed., American Forest and Paper Association, Washington, DC. (Called simply the NDS.)
3. *Manual of Steel Construction*, 8th ed., American Institute of Steel Construction, Chicago, IL, 1981. (Called simply the AISC Manual.)
4. *Building Code Requirements for Reinforced Concrete*, ACI 318-95, American Concrete Institute, Detroit, MI, 1995. (Called simply the ACI Code.)
5. *Timber Construction Manual*, 3rd ed., American Institute of Timber Construction, Wiley, New York, 1985.
6. James Ambrose, *Design of Building Trusses*, Wiley, New York, 1994.
7. James Ambrose, *Simplified Design of Building Foundations*, 2nd ed., Wiley, New York, 1988.

---

# ANSWERS TO SELECTED EXERCISE PROBLEMS

---

## Chapter 2

- 2.7.A**  $R = 80.62$  lb, upward to the right,  $29.74^\circ$  from the horizontal
- 2.7.C**  $R = 94.87$  lb, downward to the right,  $18.43^\circ$  from the horizontal
- 2.7.E**  $R = 100$  lb, downward to the left,  $53.13^\circ$  from the horizontal
- 2.7.G**  $R = 58.07$  lb, downward to the right,  $7.49^\circ$  from the horizontal
- 2.7.I**  $R = 91.13$  lb, upward to the right,  $9.495^\circ$  from the horizontal
- 2.8.A** 141.4 lb T
- 2.8.C** 300 lb C
- 2.10.A**  $19.3^\circ$
- 2.10.C** 0.7925 lb
- 2.11.A** 400 lb
- 2.11.C** 1250 lb
- 2.12.A** Sample:  $M$  about  $R_1 = + (500 \times 4) + (400 \times 6) + (600 \times 10) - (650 \times 16)$
- 2.12.B**  $R_1 = 3593.75$  lb [15.98 kN],  $R_2 = 4406.25$  lb [19.60 kN]

**2.12.D**  $R_1 = 7667 \text{ lb}$  [34.11 kN],  $R_2 = 9333 \text{ lb}$  [41.53 kN]

**2.12.F**  $R_1 = 7143 \text{ lb}$  [31.79 kN],  $R_2 = 11,857 \text{ lb}$  [52.76 kN]

### Chapter 3

**3.1.A** Sample values:  $CI = 2000 \text{ C}$ ,  $IJ = 812.5 \text{ T}$ ,  $JG = 1250 \text{ T}$

**3.2.A** Same as 3.1.A.

**3.3.A** Sample values in kips:  $DN$ , 5333 C;  $KL$ , 1500 T;  $OI$ , 6000 T;  $LM$ , 2500 C

### Chapter 4

**4.3.A** Maximum shear = 10 kips [44.5 kN]

**4.3.C** Maximum shear = 1114 lb [4.956 kN]

**4.3.E** Maximum shear = 9.375 kips [41.623 kN]

**4.4.A** Maximum  $M = 60 \text{ kip-ft}$  [80.1 kN-m]

**4.4.C** Maximum  $M = 4286 \text{ ft-lb}$  [5.716 kN-m]

**4.4.E** Maximum  $M = 18.35 \text{ kip-ft}$  [24.45 kN-m]

**4.5.A**  $R_1 = 1860 \text{ lb}$  [8.27 kN], maximum  $V = 1360 \text{ lb}$  [6.05 kN], maximum  $-M = 2000 \text{ ft-lb}$  [2.66 kN-m], maximum  $+M = 3200 \text{ ft-lb}$  [4.27 kN-m]

**4.5.C**  $R_1 = 2760 \text{ lb}$  [12.28 kN], maximum  $V = 2040 \text{ lb}$  [9.07 kN], maximum  $-M = 2000 \text{ ft-lb}$  [2.67 kN-m], maximum  $+M = 5520 \text{ ft-lb}$  [7.37 kN-m]

**4.6.A** Maximum  $V = 1500 \text{ lb}$  [6.67 kN], maximum  $M = 12,800 \text{ ft-lb}$  [17.1 kN-m]

**4.6.C** Maximum  $V = 1200 \text{ lb}$  [5.27 kN], maximum  $M = 8600 \text{ ft-lb}$  [11.33 kN-m]

**4.7.A**  $M = 32 \text{ kip-ft}$  [43.4 kN-m]

**4.7.C**  $M = 90 \text{ kip-ft}$  [122 kN-m]

### Chapter 5

**5.1.A**  $R_1 = R_3 = 1200 \text{ lb}$  [5.34 kN],  $R_2 = 4000 \text{ lb}$  [17.79 kN],  $+M = 3600 \text{ ft-lb}$  [4.99 kN-m],  $-M = 6400 \text{ ft-lb}$  [8.68 kN-m]

**5.1.C**  $R_1 = 7.67 \text{ kips}$  [33.35 kN],  $R_2 = 35.58 \text{ kips}$  [154.79 kN],  $R_3 = 12.75 \text{ kips}$  [55.46 kN]

- 5.1.E**  $R_1 = R_3 = 937.5 \text{ lb}$  [4.17 kN],  $R_2 = 4125 \text{ lb}$  [18.35 kN],  $+M = 7031 \text{ ft-lb}$  [9.53 kN-m],  $-M = 13,500 \text{ ft-lb}$  [18.31 kN-m]
- 5.1.G**  $R_1 = R_4 = 9600 \text{ lb}$  [42.7 kN],  $R_2 = R_3 = 26,400 \text{ lb}$  [117.4 kN],  $+M_1 = 46,080 \text{ ft-lb}$  [62.48 kN-m],  $+M_2 = 14,400 \text{ ft-lb}$  [19.53 kN-m],  $-M = 57,600 \text{ ft-lb}$  [78.11 kN-m]
- 5.2.A** Maximum  $V = 8 \text{ kips}$ , maximum  $+M =$  maximum  $-M = 44 \text{ kip-ft}$ , inflection at 5.5 ft from both ends
- 5.3.A**  $R_1 = 16 \text{ kips}$  [72 kN],  $R_2 = 48 \text{ kips}$  [216 kN], maximum  $+M = 64 \text{ kip-ft}$  [86.4 kN-m], maximum  $-M = 80 \text{ kip-ft}$  [108 kN-m], inflection at pin location in both spans
- 5.3.C**  $R_1 = 6.4 \text{ kips}$  [28.8 kN],  $R_2 = 19.6 \text{ kips}$  [88.2 kN],  $+M = 20.48 \text{ kip-ft}$  [27.7 kN-m] in end span and  $24.4 \text{ kip-ft}$  [33.1 kN-m] in center span  $-M = 25.6 \text{ kip-ft}$  [34.4 kN-m], inflection at 3.2 ft from  $R_2$  in end span

## Chapter 6

- 6.2.A**  $SF = 2.53$
- 6.3.A** Maximum pressure = 1098 psf, minimum pressure = 133 psf

## Chapter 7

- 7.1.A**  $R = 10 \text{ kips}$  up and  $110 \text{ kip-ft}$  counterclockwise
- 7.1.C**  $R = 6 \text{ kips}$  to the left and  $72 \text{ kip-ft}$  counterclockwise
- 7.2.A**  $R_1 = 4.5 \text{ kips}$  down,  $R_2 = 4.5 \text{ kips}$  up and  $12 \text{ kips}$  to the right

## Chapter 8

- 8.1.A**  $R = 216.05 \text{ lb}$ ,  $x = 0.769 \text{ ft}$ ,  $z = 1.181 \text{ ft}$
- 8.1.C**  $T_1 = 50.8 \text{ lb}$ ,  $T_2 = 19.7 \text{ lb}$ ,  $T_3 = 45.0 \text{ lb}$
- 8.2.A**  $R = 4 \text{ lb}$  down,  $x = 10.75 \text{ ft}$  right,  $z = 15.5 \text{ ft}$  left

## Chapter 9

- 9.1.A**  $c_y = 2.6 \text{ in.}$  [70 mm]
- 9.1.C**  $c_y = 4.2895 \text{ in.}$  [107.24 mm]

**9.1.E**  $c_y = 4.4375$  in. [110.9 mm],  $c_x = 1.0625$  in. [26.6 mm]

**9.3.A**  $I = 535.86$  in.<sup>4</sup> [ $2.11 \times 10^8$  mm<sup>4</sup>]

**9.3.C**  $I = 447.33$  in.<sup>4</sup> [ $174.74 \times 10^6$  mm<sup>4</sup>]

**9.3.E**  $I = 205.33$  in.<sup>4</sup> [ $80.21 \times 10^6$  mm<sup>4</sup>]

**9.3.G**  $I = 438$  in.<sup>4</sup>

**9.3.I**  $I = 1672.45$  in.<sup>4</sup>

## Chapter 10

**10.2.A**  $1.182$  in.<sup>2</sup> [762 mm<sup>2</sup>]

**10.2.C** 27.0 kips [120 kN]

**10.2.E** Not acceptable; actual stress exceeds allowable

**10.3.A** 19,333 lb [86 kN]

**10.3.C** 29,550,000 psi [203 GPa]

## Chapter 11

**11.2.A** Okay, actual stress = 13.99 ksi, less than allowable of 24 ksi

**11.3.A** 38.6 kips

**11.3.C** 20.5 kips

**11.3.E** 22.6 kips

**11.4.A** W 12 × 22 or W 14 × 22 (lightest); also W 10 × 26, W 8 × 31

**11.4.C** W 18 × 35

**11.5.A** At neutral axis,  $f_v = 811.4$  psi; at junction of web and flange,  $f_v = 175$  and 700 psi

**11.6.A** 168.3 kips

**11.6.C** 37.1 kips

**11.7.A** 6.735 kips

**11.9.A** 0.80 in. [20 mm]

**11.10.A** 13.6%

**11.10.C** 51.5%

## Chapter 12

**12.2.A** 15,720 lb

**12.3.A** 235 kips [1046 kN]

**12.3.C** 274 kips [1219 kN]

### Chapter 13

**13.1.A** 3183 psi tension, 2929 psi compression

**13.2.A** (a) 3.04 ksf [151 kPa]; (b) 5.33 ksf [266 kPa]

**13.4.A**  $f = 933$  psi [6.43 MPa],  $v = 250$  psi [1.72 MPa]

**13.4.C**  $f = 750$  psi [5.17 MPa],  $v = 433$  psi [2.99 MPa]

### Chapter 14

**14.2.A** 6 bolts, outer plates  $\frac{1}{2}$  in., middle plate  $\frac{5}{8}$  in.

**14.3.A** Rounding up to the next full inch,  $L_1 = 11$  in.,  $L_2 = 5$  in.

**14.3.C** Minimum of 4.25 in. weld on each side

### Chapter 15

**15.2.A** Width required to get bars into one layer is critical; least width is 16 in. with  $h = 31$  in. and five No. 10 bars

**15.2.C** From work for Problem 15.2.A., this section is under-reinforced; find actual  $k = 0.347$ ,  $j = 0.884$ , required area of steel = 5.09 in.<sup>2</sup>, use four No. 10 bars

**15.4.A** With  $d = 11$  in.,  $A_s = 3.67$  in.<sup>2</sup>; with  $d = 16.5$  in.,  $A_s = 1.97$  in.<sup>2</sup>

**15.5.A** 5.76 in.<sup>2</sup> [ $3.71 \times 10^3$  mm<sup>2</sup>]

**15.7.A** Possible choice for spacing: 1 at 6 in., 8 at 13 in.

**15.7.C** 1 at 6 in., 4 at 13 in.





---

# INDEX

---

- Accuracy of computations, 3
- Active soil pressure, 184
- Algebraic analysis of,
  - forces, 89
  - truss, 120
- Allowable deflection, 277
- Allowable loads for:
  - fillet welds, 347
  - steel:
    - bolts, 322
    - columns, 301
    - welded joints, 347
    - wood: columns, 297
- Allowable stress design, 354
- Allowable stress, 243, 355
- Angles, structural steel, 235
  - gage for bolts, 334
  - properties of, 235
  - in tension, 336
- Approximate analysis of structures, 181
- Architectural elements, 23
- Areas of steel reinforcing bars, 363
- Balanced reinforcement:
  - strength design, 378
  - working stress design, 367
- Balanced section, 367, 378
- Bars, reinforcing, 363
- Beams:
  - analysis of, 132, 259
  - bending in, 140
  - cantilever, 133, 151
  - concentrated load, 134
  - concrete, 363
  - connections, steel, 324
  - continuous, 134, 160
  - deflection, 275
  - diagrams, typical loadings, 155

- distributed load, 134
  - effective depth, 365
  - fixed-end, 172
  - flexure formula, 257
  - flitched, 272
  - forces on, 102
  - indeterminate, 162
  - inflection, 147
  - with internal pins, 176
  - internal resisting moment, 255
  - investigation of, 132, 259
  - loading, 13
  - moment diagram, 142
  - moment in, 255
  - neutral axis, 216, 256
  - overhanging, 107, 133
  - reactions, 105
  - resisting moment in, 255
  - restrained, 172, 290
  - safe load tables for, steel,
  - sense (sign) of bending, 147
  - shear diagram, 139
  - shear in, 135, 265, 270, 387
  - simple, 105, 133
  - statically indeterminate, 162
  - steel, 270
  - strength design of, 355
  - stresses in, 254
  - T-beams, 382
  - tabular data for, 155
  - theorem of three moments, 163
  - types of, 133
  - typical loadings, 155
  - under-reinforced, 373
  - uniformly distributed load, 134
  - vertical shear, 136
  - width, concrete, 372
- Bending, 41**
- in bolted connection, 327
  - in concrete beams, 383
  - resistance, 255
  - stress, 257
- Bending moment:**
- in beam, 140
  - diagrams, 142
  - negative, 147
  - positive, 147
- Blast load, 12**
- Block shear failure, 329, 341**
- Bolted connections, 324**
- bearing in, 327
  - bending in, 328
  - effective net area, 327, 336, 339
  - gage for angles, 334
  - layout of, 332
  - tearing in, 329, 341
  - tension stress in, 327, 335
- Bolts:**
- capacity of, in steel, 332
  - edge distance for in steel, 333
  - high-strength, 331
  - spacing in steel, 334
  - unfinished, 331
- Bow's notation, 85**
- Buckling, 30, 294**
- Built-up sections in steel, 226**
- Cantilever:**
- beam, 133, 151
  - frame, 193
  - retaining wall, 183
- Cement, 353, 358**
- Center of gravity, 2**
- Centroid, 215**
- Channels, steel, 234**
- Classification of force systems, 75**
- Coefficient of friction, 92**
- Columns:**
- buckling, 294
  - end conditions, 302
  - relative slenderness of, 293
  - slenderness of, 293
  - steel, 301
  - wood, 297

- Combined
  - axial force and moment, 309
  - load, 20
  - stress, 49, 321
- Component of a force, 81
- Composite construction, 58
- Compression, 39
  - in columns, 293
- Computations, 3
- Concentrated load, 134
- Concurrent force systems, 76, 203
- Concrete:
  - balanced section properties, 367, 378
  - beam, 363
  - cast-in-place, 354
  - cover, 361
  - design methods, 253, 375
  - k-factors for beams, 369
  - modulus of elasticity, 357
  - reinforced, 354
  - reinforcement for, 358, 363
  - shear in, 387
  - sitecast, 354
  - stirrup, 389
  - stiffness, 357
  - strength of, 356
  - T-beam, 382
- Connection:
  - bolted, steel, 324
  - tension, 327, 335
  - welded, 343
- Continuous action of beams, 134, 160
- Conversion factors for units, 3, 6
- Couple, 99
- Cover, of reinforcement, 361
- Cracked section, 314
- Cut section, 66
  
- Damping effect on harmonic motion, 63
- Dead load, of building construction, 14
  
- Deflection:
  - allowable, 277
  - of beams, general, 275
  - computations, 279
  - formulas, typical loadings, 155
  - of steel beams, 280
  - of wood beams, 281
- Deformation, 2, 241
  - and stress, 239, 246
- Design methods, 354
- Development of resisting moment, 255
  - in concrete beam, 363
- Dispersion of load, 16
- Direct stress, 46
- Double shear, 48, 252, 327
- Ductility, 48
- Dynamic behavior, 61
- Dynamic effects, 61
  - harmonic motion, 62
  - motion, 61
- Dynamics, 2
  
- Earth pressure, 184
- Earthquake, 12, 19
- Eccentric load, 309
- Edge distance of bolts in steel, 353
- Effective:
  - column length, 296
  - depth of concrete beam, 365
  - net area in tension, 336, 339
  - width of concrete T-beam flange, 382
- Elastic limit, 48, 246
- Equilibrant, 82
- Equilibrium, 36, 77, 203
  - static, 2
- Euler buckling formula, 33
  
- Factored load, 356
- Factor of safety, 247
- Fillet weld, 344

- Fixed end beam, 172
- Flexure formula, 257
- Fitched beam, 272
- Floors, 23
- Force:
  - actions, 69
  - algebraic solution, 89,
  - on beam, 102
  - classification of systems, 75
  - composition, 78, 81
  - equilibrant, 82
  - equilibrium, 36, 77, 203
  - graphical analysis, 83, 88
  - internal, 28, 39
  - investigation, 87
  - line of action, 74
  - notation for truss analysis, 85
  - parallelogram, 79
  - point of application, 74
  - polygon, 83
  - properties, 74
  - resolution, 78
  - resultant, 78
  - systems, 75, 202
  - types, 72
- Free body diagram, 65, 194
- Friction, 91
- Functional requirements of structures, 30
- Fundamental period, 5
- Gage in angles, 334
- Generation of structures, 21
- Graphical analysis of :
  - forces, 83, 88
  - truss, 11
- Handling load, 12
- Harmonic motion, 62, 68
- High strength bolts, steel, 331
- Hooke's Law, 246
- Horizontal:
  - earth pressure, 184
  - shear, 136
- Hydraulic load, 12
- Indeterminate structures, 162
- Inelastic behavior, 251
- Inflection in beams, 147
- Internal forces, 12, 28, 39
  - in beams, 43, 255
  - combined, 45
  - in rigid frames,
  - in trusses, 111
- Internal pins in continuous beams, 176
- Internal resisting moment, 255
- Investigation of:
  - beams, 132, 259
  - columns, 297, 301
  - forces, 87
  - frames, 192
  - trusses, 111, 120
- Joints, method of, 111, 120
- Kern, 314
- k factors for concrete beams, 369
- K factors for steel columns, 302
- Lateral unsupported length of
  - columns, 30, 297, 301
- Line of action of a force, 74
- Live load, 14
- Load, 11, 69
  - blast, 12
  - combined, 20
  - concentrated, 16
  - dead (DL), 14
  - dispersion, 16
  - distributed, 16
  - earthquake, 12
  - eccentric, 309

- factored, 356
- gravity, 11
- handling, 12
- hydraulic, 12
- internal action, 12
- live (LL), 14
- service, 355
- shrinkage, 12
- uniformly distributed, 16
- vibration, 12
- wind, 11, 17
- LRFD (load and resistance factor design), 356
- Lumber, properties of standard sizes, 237
- Maxwell diagram, 113
- Measurement, units of, 2
- Mechanical couple, 99
- Mechanics, 2
- Method of joints, 111, 120
- Minimum reinforcement, 373
- Modulus:
  - of elasticity for direct stress, 48, 248, 357
  - section, 228
- Moment, 97
  - arm, 97
  - beams, 140, 255
  - diagram for beam, 142
  - of a force, 97
  - general definition, 97
  - of inertia, 218
  - internal bending moment, 43, 255
  - of a mechanical couple, 99
  - negative, 147
  - overturning, 186
  - positive, 147
  - resistance, 255
  - restoring, 188
  - sense of, 147
  - stabilizing, 188
  - statical, 217
- Moment of inertia, 218
- Motion, 76
- Net section:
  - in shear, 329, 341
  - in tension, 327, 336, 339
- Neutral axis, 216, 256
- Nomenclature, 7
- Noncoplanar forces, 202
- Nonlinear behavior, 251
- Oblique section, 49, 319
- Overturning moment on retaining wall, 186
- Passive soil pressure, 184
- Parallel forces, 76, 102, 209
- Parallelogram of forces, 79
- Permanent set, 247
- Pin, internal, 176
- Pitch of bolts, 334
- Plastic:
  - behavior of steel, 283
  - hinge, 286
  - moment, 286
  - section modulus, 287
- Point of inflection, 147
- Polygon of forces, 83
- Portland cement, 353
- Pressure:
  - soil, 184
  - wedge method, 315
- Properties of:
  - forces, 74
  - geometric shapes, 230
  - reinforcing bars, 363
  - sections, 214
- Properties of sections:
  - built-up, 217, 226

- Properties of sections: (*cont.*)
  - centroid, 215
  - channels, 234
  - geometric shapes, 230
  - kern, 314
  - lumber, 237
  - moment of inertia, 218
  - plastic section modulus, 287
  - radius of gyration, 30, 229
  - section modulus, 228
  - single angle shapes, 235
  - statical moment, 217
  - steel angles, 235
  - steel channels, 234
  - steel pipe, 236
  - structural lumber, 237
  - transfer axis theorem, 223
  - W shapes, 232
- Radius of gyration, 30, 229
- Reactions, 24, 105
- Rectangular:
  - beam in concrete, 363
  - stress block, strength method, 364, 376
- Reinforced concrete, 354
- Reinforcement for concrete, 358
- Relation of shear and moment, 144
- Relative:
  - slenderness, 30, 293
  - stiffness of columns, 295
- Resistance factor, 356
- Restrained beam, 172, 290
- Restoring moment, 188
- Resultant of forces, 78
- Retaining wall, 183
- Rigid frame, 192
- Roofs, 23
  
- S, elastic section modulus, 228
- Safe load tables for:
  - fillet welds, 347
  - steel bolts, 332
- Safety, 247
- Section:
  - balanced, 367
  - cut, 66
  - cracked, 314
  - net, 323, 336, 339
  - properties, 214
- Section modulus:
  - elastic, 228
  - plastic, 287
- Sense of:
  - force, 74
  - bending, 147
- Separated joint diagram, 113
- Service load, 355
- Shapes, steel, 302
- Shear, 40
  - in beams, 135, 265
  - in bolts, 326
  - in concrete beam, 387
  - diagram for beam, 139
  - double, 327
  - horizontal, 136, 265
  - reinforcement, 389
  - single, 327
  - in steel beam, 70
  - stress, 245, 317
- Shrinkage load, 12
- Sitecast concrete, 354
- Simple beam, 105
- Simple support, 105
- Single shear, 327
- Slenderness, 30
  - of columns, 293
- Soil pressure, 184
- Solid-sawn wood element, 297
- Space diagram, 112, 372
- Spacing of:
  - bars in concrete, 361
  - steel bolts, 334
  - stirrups, 393
- Spanning structure, 22

- Stability, 30
  - of retaining wall, 186
- Standard notation, 7
- Static equilibrium, 2, 77
- Static versus dynamic force, 14
- Statistical moment, 217
- Statically indeterminate:
  - beam, 162
  - frame, 199
- Statics, 2
- Steel:
  - allowable stresses, 243
  - angle, 235
  - bolts, 324
  - columns, 301
  - connections, 324
  - pipe, 236
  - reinforcement, 358
- Stiffness, 36, 248
  - relative, 30
- Stirrups, 389
  - spacing of, 393
- Strain:
  - general definition, 2, 46, 243
  - hardening, 247
- Strength, 34, 242
  - of concrete, 356
  - design method, 253, 375
  - of materials, 2, 242
  - yield, 246
  - ultimate, 253
- Stress, 2, 46, 71, 243
  - allowable, 243, 355
  - in beams, 254
  - bending, 140, 255
  - combined, 49
  - compression, 46
  - design, 354
  - and deformation, 239, 246
  - development of internal force, 46
  - direct, 46
  - in ductile material, 48
  - flexural, 43
  - general definition, 2
  - inelastic, 257
  - kinds of, 46
  - method, 354, 363
  - on oblique section, 49, 319
  - in plastic range, 251
  - shear, 245, 31
  - in soils, 184
  - strain behavior, 46
  - strength method, 355
  - tensile, 46
  - thermally-induced, 12, 53
  - types of, 46
  - ultimate, 247
  - unit, 243
  - working, method, 354, 363
  - yield, 246
- Stress-strain, 46
  - diagram, 48, 248, 357
  - ductility, 48
  - modulus of elasticity, 48, 248, 357
  - proportional limit, 243
  - relations, 46
  - time-related, 59
  - yield stress, 243
- Stirrup, 389
- Structural:
  - analysis, 1
  - investigation, 1, 64
  - mechanics, 2
  - response, 64
- Structures:
  - composite, 58
  - functional requirements, 30
  - generation of, 21
  - spanning, 21
- Symbols, 7
- T-beam, concrete, 382
- Tearing in bolted connection, 329, 341
- Tension, 39

- and combined bending, 309
- in bolted connection, 327, 335
- Tension elements:
  - effective area in, 336, 339
  - net section in, 336, 339
  - upset end, threaded rod, 244
- Three Moment Theorem, 163
- Thermally-induced stress, 12, 53
- Throat of weld, 345
- Time-dependent behavior, 61
- Torsion, 41, 45
- Trusses:
  - algebraic analysis, 120
  - Bow's notation of forces for, 85
  - graphical analysis, 111
  - internal forces in, 111
  - investigation, methods, 111, 127
  - joints, method of, 111, 120
  - Maxwell diagram for, 113
  - notation of forces for, 85
  - sections, method of, 127
  - separated joint diagram, 113
  - space diagram, 112
- Ultimate stress, 247
- Under-reinforced concrete beam, 373
- Unfinished bolt, 331
- Uniform Building Code, UBC, 7
- Uniformly distributed load, 134
- U.S. units, 2
- Units of measurement, 2
  - conversion of, 3, 6
- Unit stress, 243
- Upset end, 244
- Vector, 73
- Velocity of wind, 18
- Vertical:
  - shear, 136
  - soil pressure, 188
- Vibration, 12
- W shapes, steel, properties of, 232
- Walls, 23
- Welded connections, 343
- Welds, fillet, 344
- Width of concrete beam, 372
- Wind, 11, 17
- Wood:
  - allowable stresses for, 243
  - columns, 297
  - deflection of beams, 281
  - properties of structural lumber, 237
- Working stress method, 355
- Yield:
  - point, 246
  - stress, 246
- Z, plastic section modulus, 287